

BATTLE STRIKERS™ METAL XS™

TURBO TOPS

29640



ULTIMATE ARENA TOURNAMENT
TORNEO ÚLTIMA ARENA
TOURNOI DE L'ARÉNA ULTIME
TURNIER IN DER ULTIMATIVEN ARENA
UITERST ARENA TOERNOOI
TORNEO ARENA MASSIMA
BATALHA NA MELHOR ARENA

ATTACK • ATAQUE • ATTAQUE
ANGRIFF • AANVALLEN • ATTACCO • ATAQUE

4.0

DEFENSE • DEFENSA • DÉFENSE
VERTEIDIGING • VERDEDIGEN • DIFESA • DEFESA

5.5

CONTROL • CONTROL • CONTRÔLE
STEUERUNG • BESTUREN • CONTROLLO • CONTROLLO

3.0

SENTINEL.XS™ TEAM PHANTOM™

ATTACK • ATAQUE • ATTAQUE
ANGRIFF • AANVALLEN • ATTACCO • ATAQUE

5.5

DEFENSE • DEFENSA • DÉFENSE
VERTEIDIGING • VERDEDIGEN • DIFESA • DEFESA

3.0

CONTROL • CONTROL • CONTRÔLE
STEUERUNG • BESTUREN • CONTROLLO • CONTROLLO

4.0

RAPTOR.XS™ TEAM PREDATOR™

TEAM **PHANTOM™**

4.0
2.5
6+

MECHA EX DRAGON™
29775

5.5
3.5
3.5

PYROTAUR™
29780

3.0
5.0
4.5

GRIMNIR™
29783

3.5
6.0
3.0

ODINSKULL™
TEAM PHANTOM™
29788

TEAM **PALADIN™**

6+
2.5
4.0

MECHA EX MASUMAI™
29774

4.5
4.0
4.0

VALKYRIA™
29779

5.5
4.0
3.0

REBELON™
29782

6.0
2.0
4.5

X-CALIBUR™
TEAM PALADIN™
29787

TEAM **PREDATOR™**

3.0
6+
3.5

MECHA EX TALONTHOR™
29776

4.5
5.0
3.0

ASLEON™
29778

5.0
4.0
3.5

FANGRIR™
29781

4.5
3.5
4.5

MEGALODON™
TEAM PREDATOR™
29786

Collect, Mix, Match & Customize! • ¡Colecciona, combina, une y personaliza! • Collectionne, interchange, assemble et personnalise ! •
Große Auswahl zum Sammeln und Gestalten! • Verzamelen, mengen, vergelijken en aanpassen! •
Collezione, Mischia, combina e personalizza • Colecciona, mistura, combina e personaliza!

www.battlestrikers.com

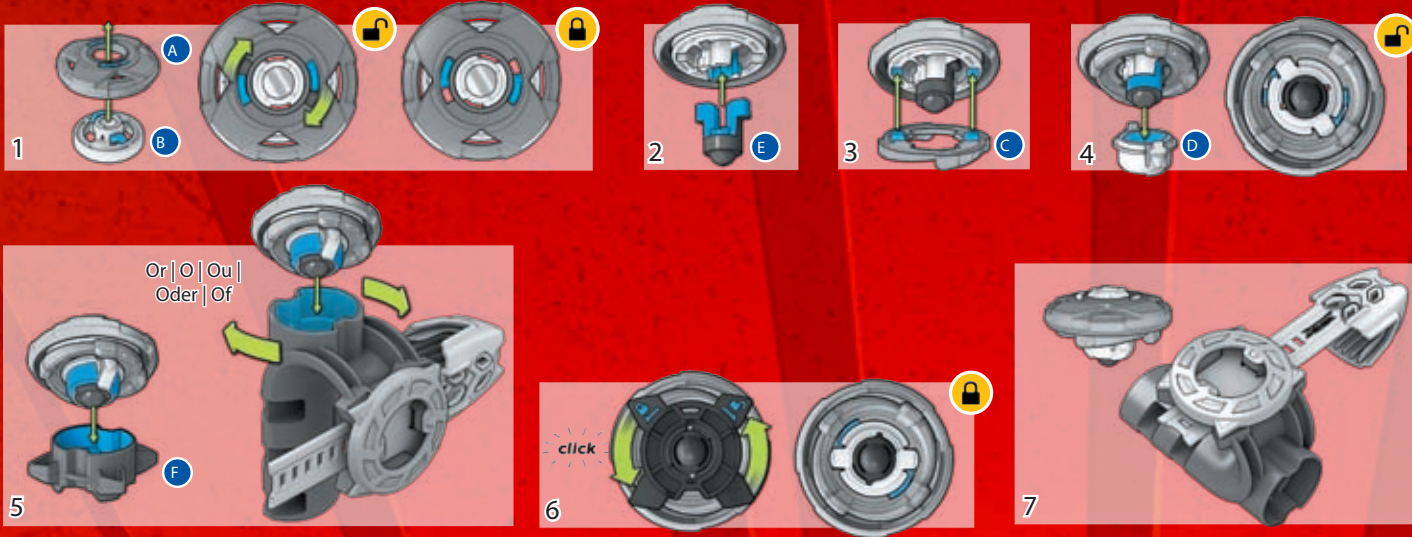

Metal XS™ Striker components are not compatible with Series 1 components. Los componentes del Striker Metal XS™ no son compatibles con los componentes de la serie 1. Les composants du Striker Metal XS™ ne sont pas compatibles avec les composants de la série 1. Metal XS™-Komponenten sind nicht mit Komponenten der Serie 1 kompatibel. Metal XS™ Striker onderdelen zijn niet compatibel met Serie 1 onderdelen. I componenti degli Striker Metal XS™ non sono compatibili con i componenti degli Striker della Serie 1. Os componentes do Metal XS™ Striker são compatíveis com os componentes da série 1.

Customize your Ultimate Arena / Personaliza tu Última Arena Personalise ton aréna ultime / Gestalte die Ultimative Arena nach deinem Geschmack / Maak uw uiterste arena naar uw smaak / Personalizza la tua arena massima Personaliza a tua melhor Arena

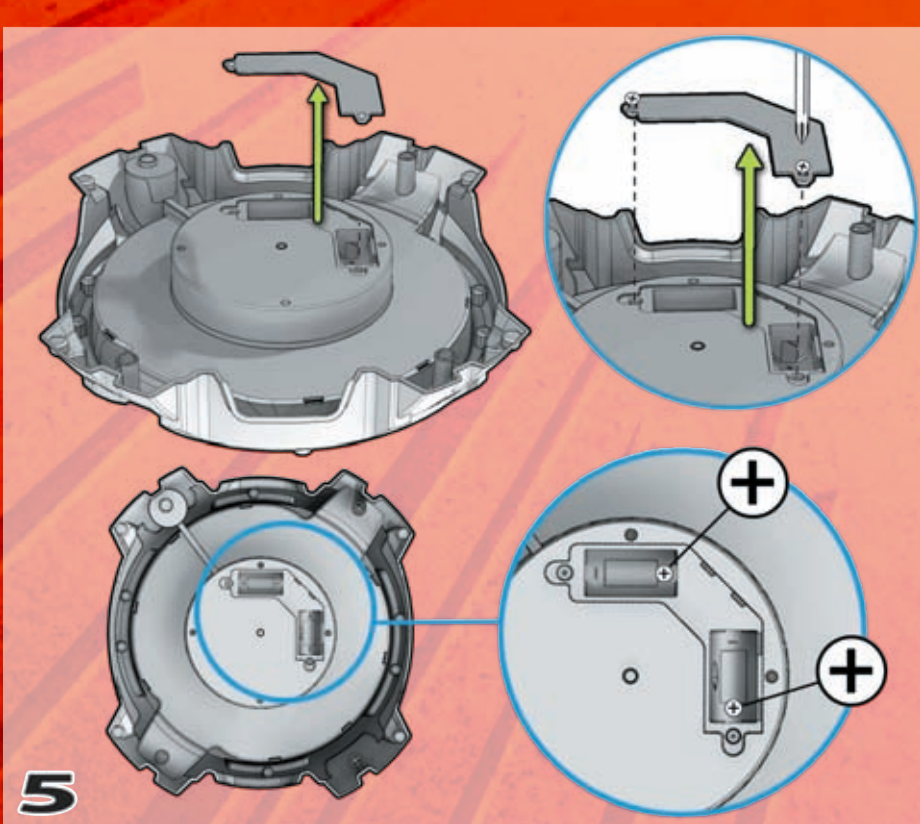
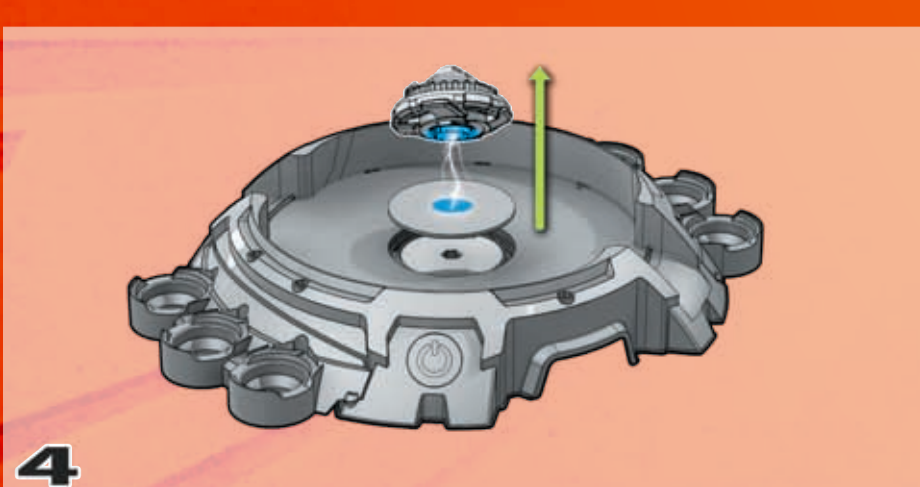
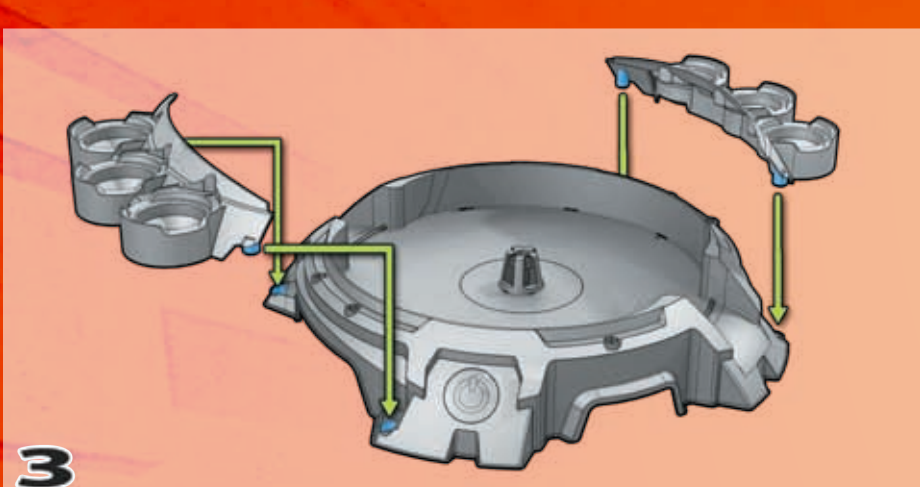
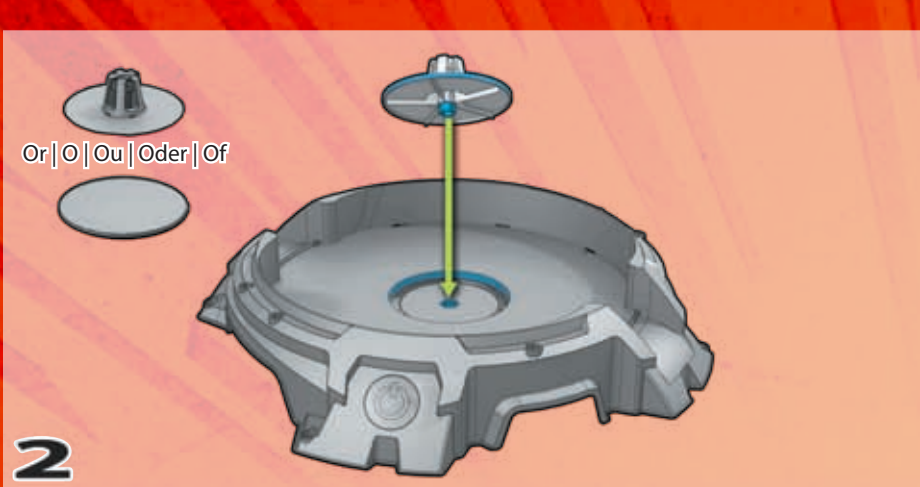
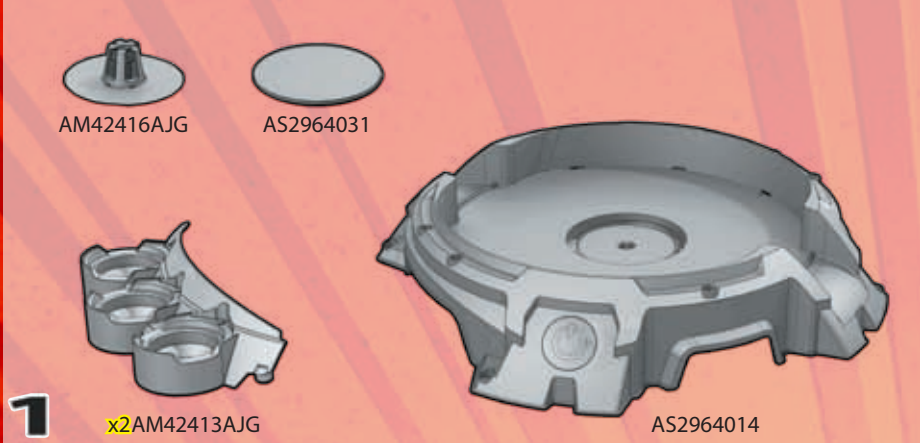

2X Batteries not included. No incluye pilas. Piles non comprises. Batterien nicht inbegriffen. Batterijen niet inbegrepen. Batterie non fornite. Pilhas não incluídas.

This toy uses 2 alkaline batteries (C, LR14, 14A or equivalent). Este juguete utiliza 2 pilas alcalinas (C, LR14, 14A o equivalente). Ce jouet nécessite 2 piles alcalines (C, LR14, 14A ou l'équivalent). Dieses Spielzeug wird mit 2 Alkali-Batterien betrieben (C, LR14, 14A oder Entsprechung). Dit speelgoed gebruikt 2 alkaline batterijen (C, LR14, 14A of gelijkwaardig). Questo giocattolo usa 2 batterie alcaline (C, LR14, 14A o equivalente). Este brinquedo emprega 2 pilhas alcalinas (C, LR14, 14A ou equivalente).

RAPTOR.XS™		SENTINEL.XS™		WEAPON PROFILE / PERFIL DEL ARMA / PROFIL D'ARMEMENT / WAFFENPROFIL / WAPENPROFIEL / PROFILO ARMA / PERFIL DA ARMA									
ATK™ AS2964015	SYN™ AS2964018	ATK™	DEF™	REC™	SYN™	HYB™	FN™						
MAGNETIC CORE AS2964017	MAGNETIC CORE AS2964020	NÚCLEO MAGNÉTICO / NOYAU MAGNÉTIQUE / MAGNETKERN / MAGNETISCHE KERN / NUCLEO MAGNETICO / NUCLEO MAGNETICO											
B-FAN™ AM42391WR	B-RIM™ AM42392SX	BOOSTER / PROPULSOR / PROPULSEUR						B-CTRL™	B-STAM™	B-BAL™	B-SLY™	B-RIM™	B-FAN™
LOCKING MECHANISM AM42213MW	LOCKING MECHANISM AM42213KJ	MECANISMO DE BLOQUEO / DISPOSITIF DE VERROUILLAGE / VERRIEGELUNG / VERGRENDELMECHANISME / MECCANISMO DI BLOCCO / MECANISMO DE TRAVAMENTO						LM13™					
TORB™ AM42223WR	TARC™ AM42399KJ	TIPS / PIEZAS / EMBOUTS / AUFSÄTZE / DEEL / PUNTE / PONTAS											
T.CTRL™ TORB™ T.CTRL+™ T.BAL™ T.STAM™ T.STAM+™ T.MAG™ T.ATK™ T.SHRP™ TARC™ T.FLEX™													

You control the battle! / ¡Tú tienes el poder! / Tu contrôles la bataille! / Du kontrollierst das Spiel! / Jij controleert het gevecht! / Tu controlla la battaglia! / Tu controlas a batalha!

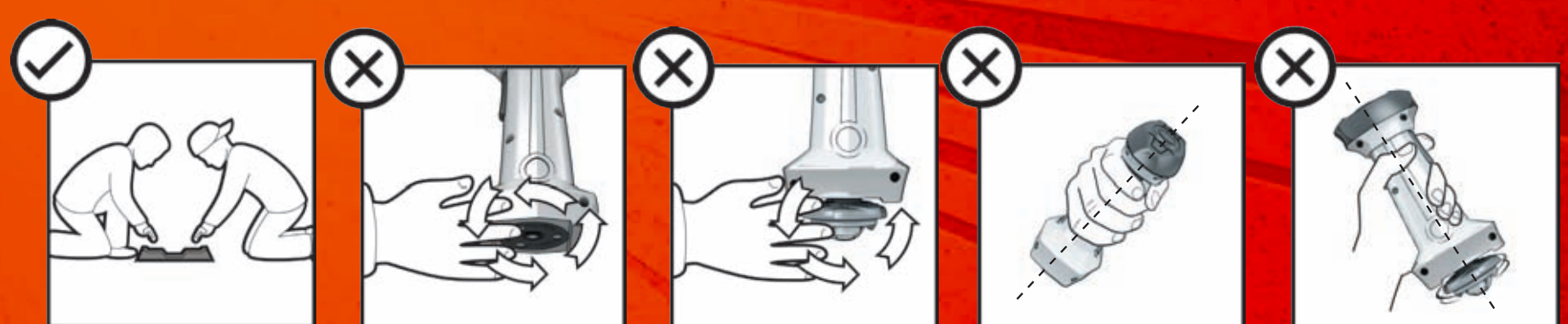
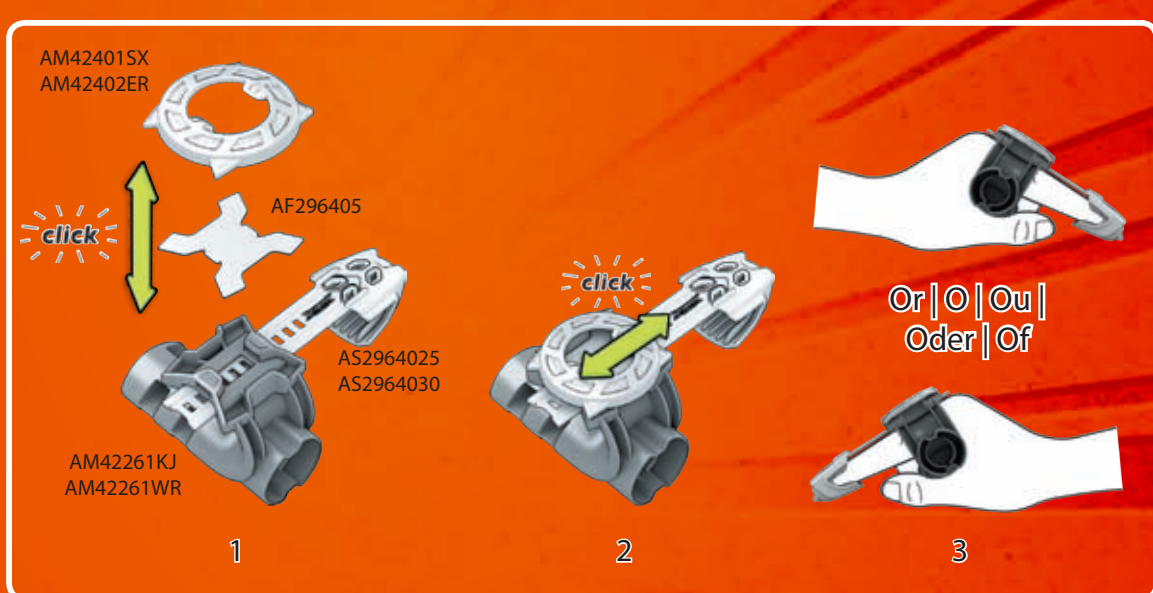
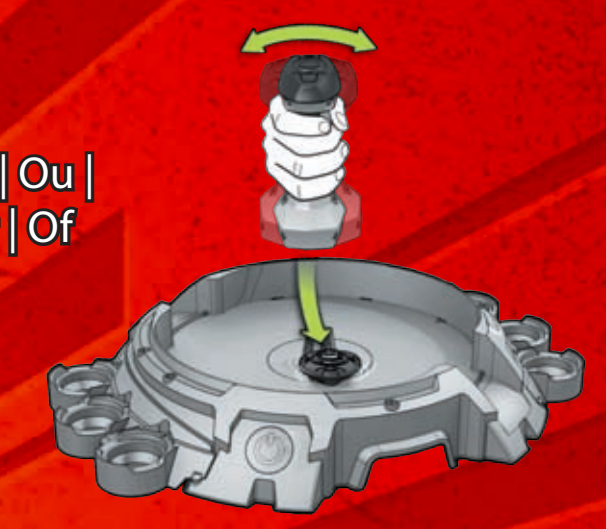
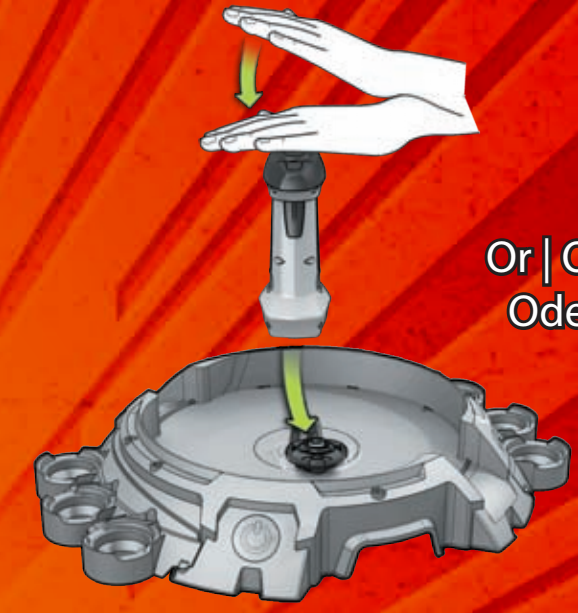
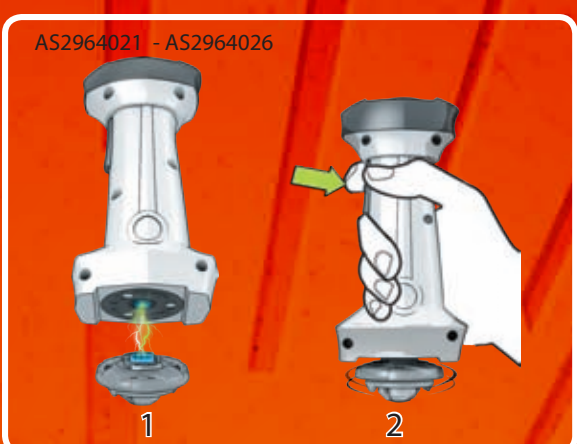

• While launcher is activated, do not touch or block the spinning puck or top. See troubleshooting section. • Mientras el lanzador esté activo, no toque ni bloquee el disco girador ni la tapa. Consultar la sección de resolución de problemas. • Lorsque le déclencheur est activé, il est important de ne pas toucher ou bloquer la plaque tournante ou la toupie. Voir la section d'aide. • Wenn der Starter betätigt wird, dürfen weder Drehscheibe noch Kreisel berührt oder angehalten werden. Siehe Abschnitt Problemlösung. • Raak wanneer de lanceerriem geactiveerd is de puck of top niet aan en blokkeer deze niet. Zie het hoofdstuk over problemen oplossen. • Quando il lanciatore viene attivato, non toccare o bloccare il dischetto o la trottole mentre è in rotazione. Guarda nella sezione per la soluzione dei problemi. • Enquanto o lançador estiver ativo, não tocar nem bloquear o disco giratório ou o pião. Ver a seção de resolução de problemas.

• Spin and/or release tops from launchers in a vertical, upright position only. • Haz girar y/o libera las peonzas desde el lanzador únicamente en posición vertical y recta. • Faites tourner et/ou lancez les toupies des déclencheurs en position verticale seulement. • Der Kreisel darf nur in aufrechter, senkrechter Position mittels des Kreiselstarters gestartet oder gedreht werden. • Draai en/of lanceer de tollen alleen verticaal met de top naar boven uit de lanceerders. • Fai ruotare e/o lancia le trottole dai lanciatori solo mentre in posizione verticale, eretta. • Soltar os piões e/ou fazê-los girar com os lançadores apenas em posição vertical e direita.

www.battlestrikers.com

Collect them all!
 ¡Coleccionalas todas!
 Collectionne-les tous!
 Sammle alle!
 Verzamel ze allemaal!
 Collezionali tutti!
 Colección todo!

