



STAR WARS

TM



8089



1

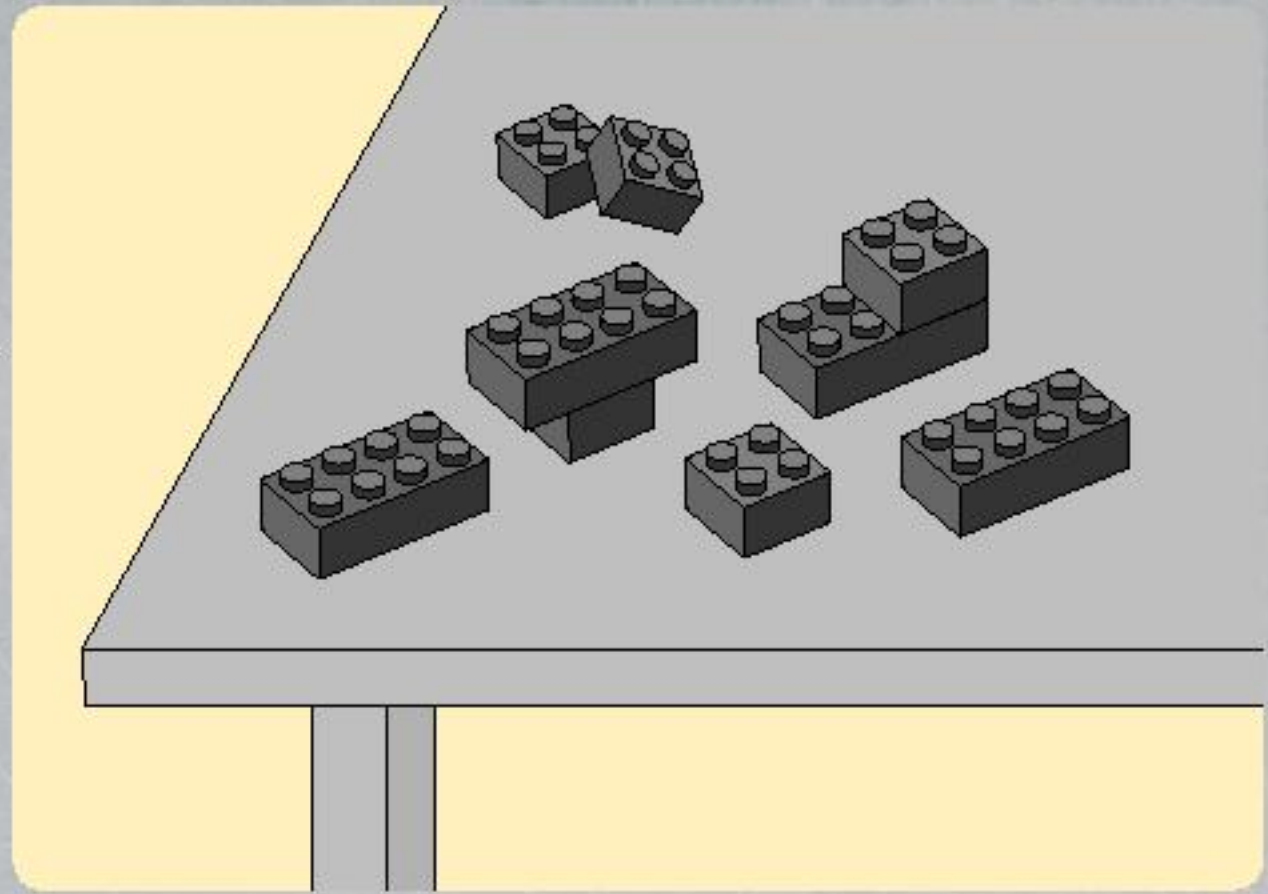
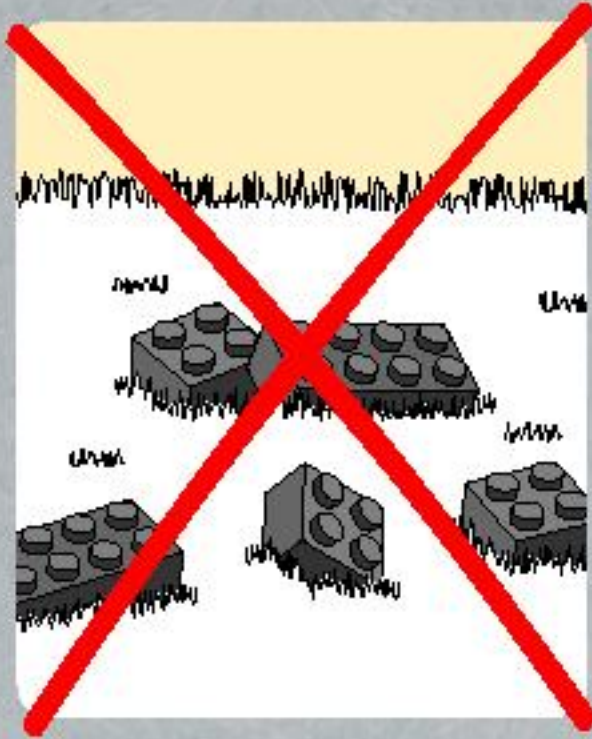

2



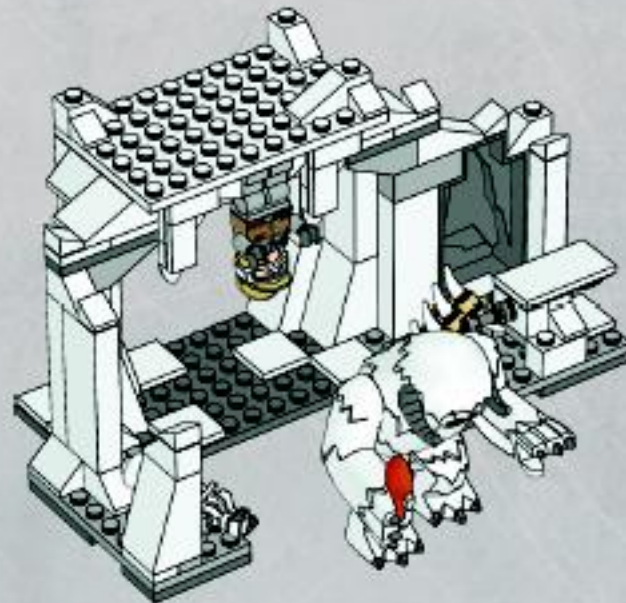
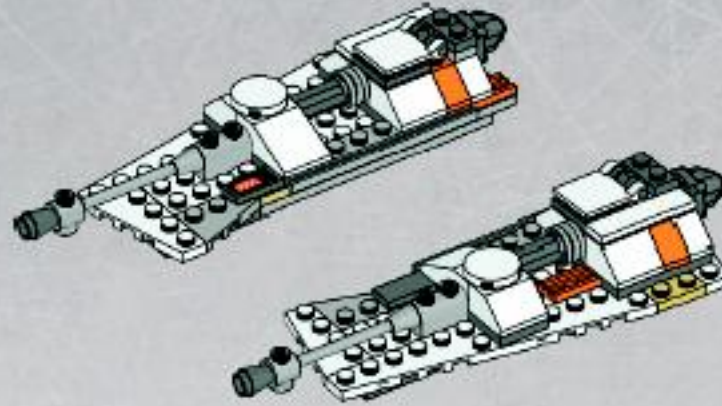
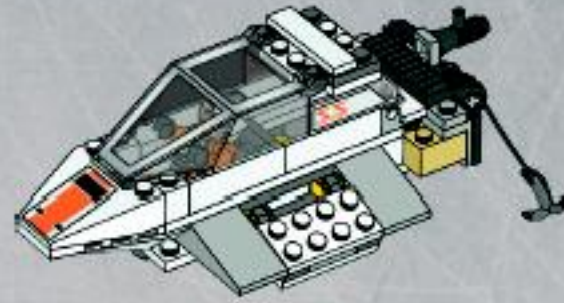

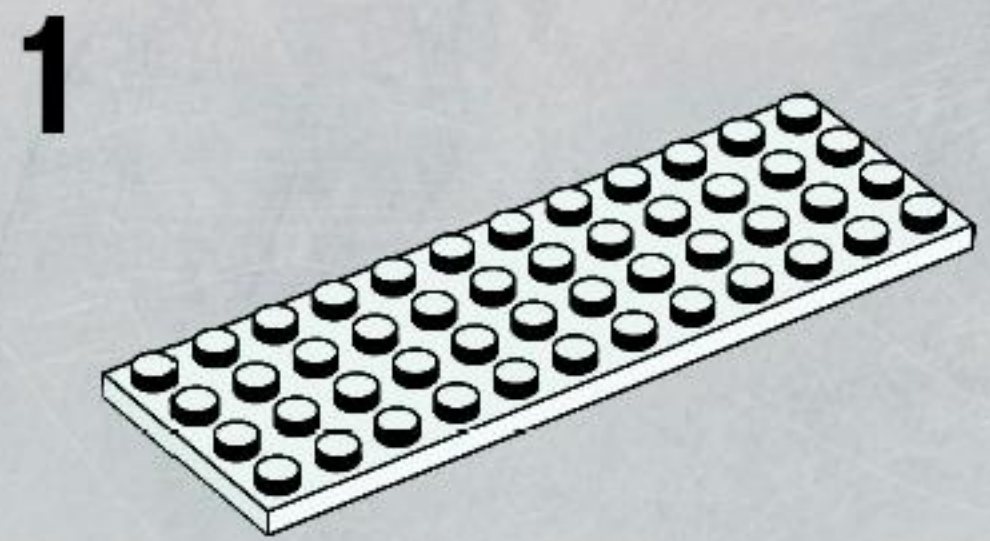
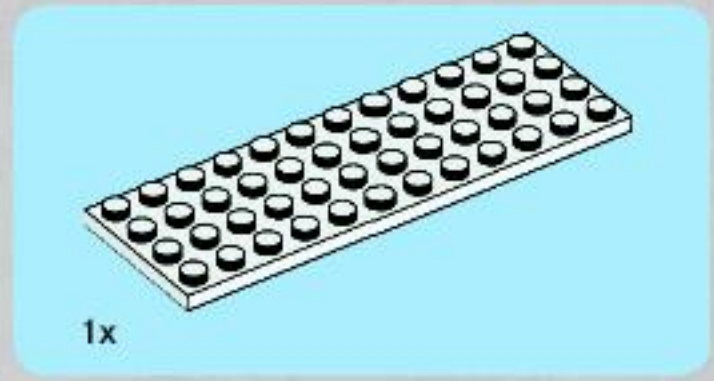
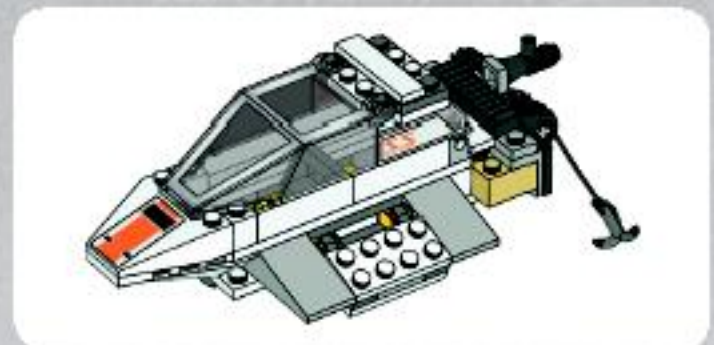
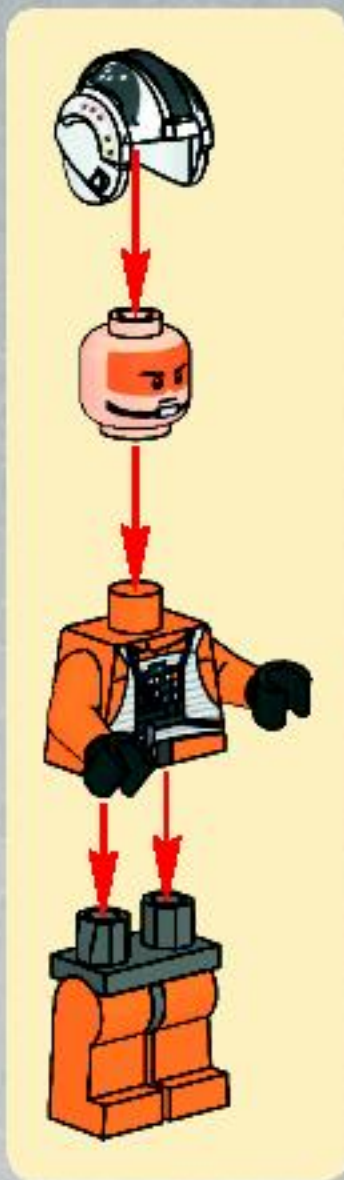
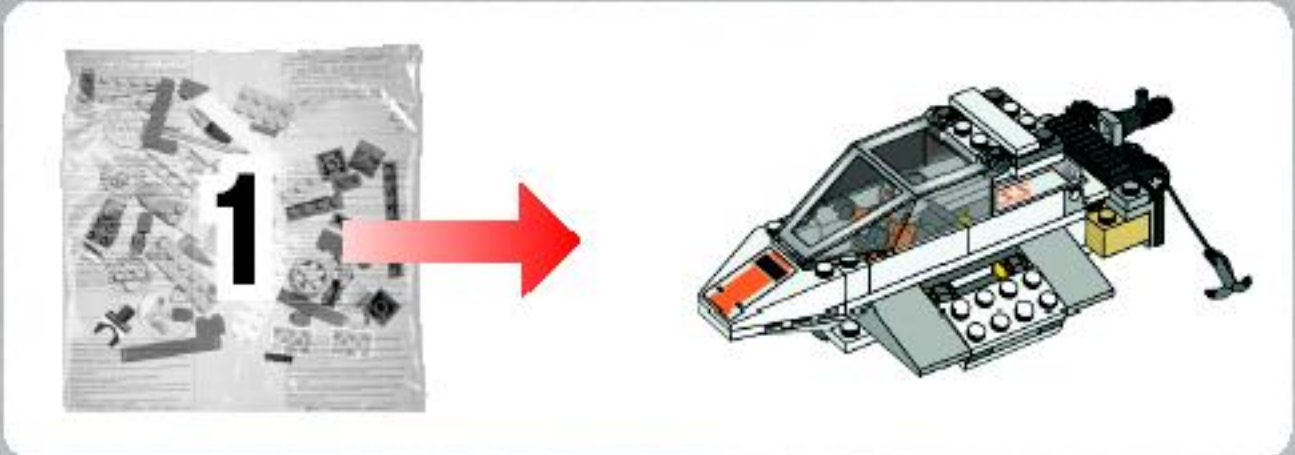

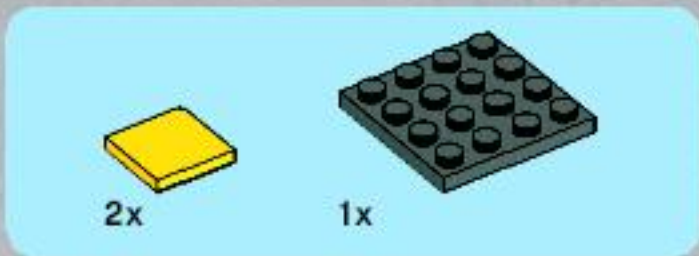

2

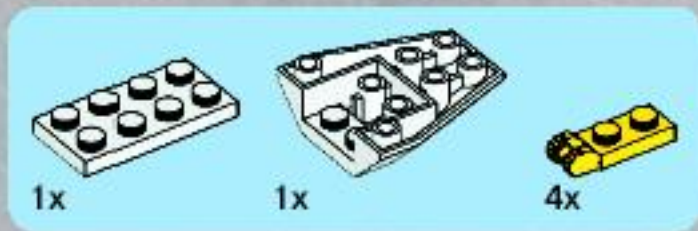
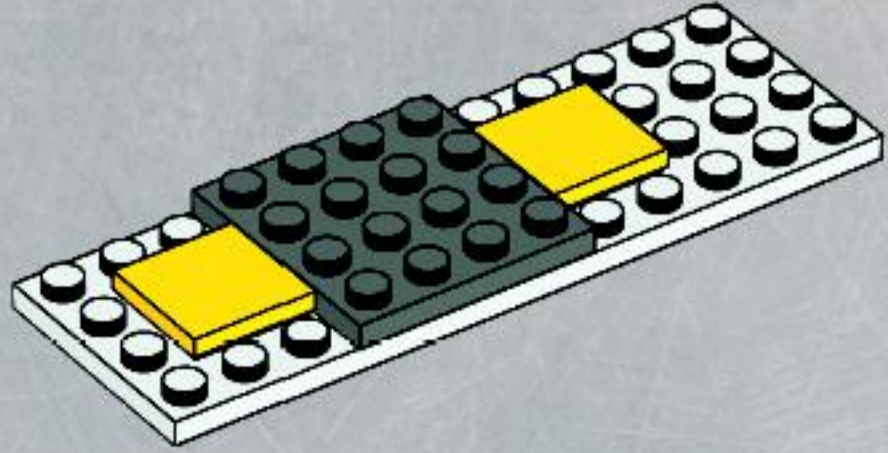

4

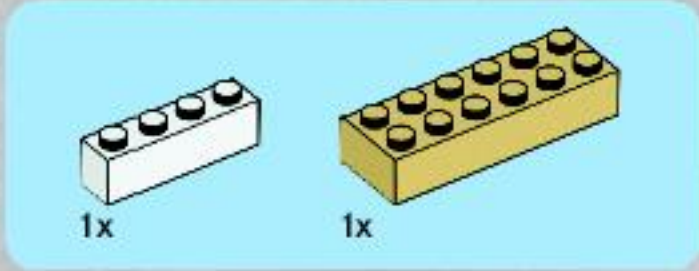
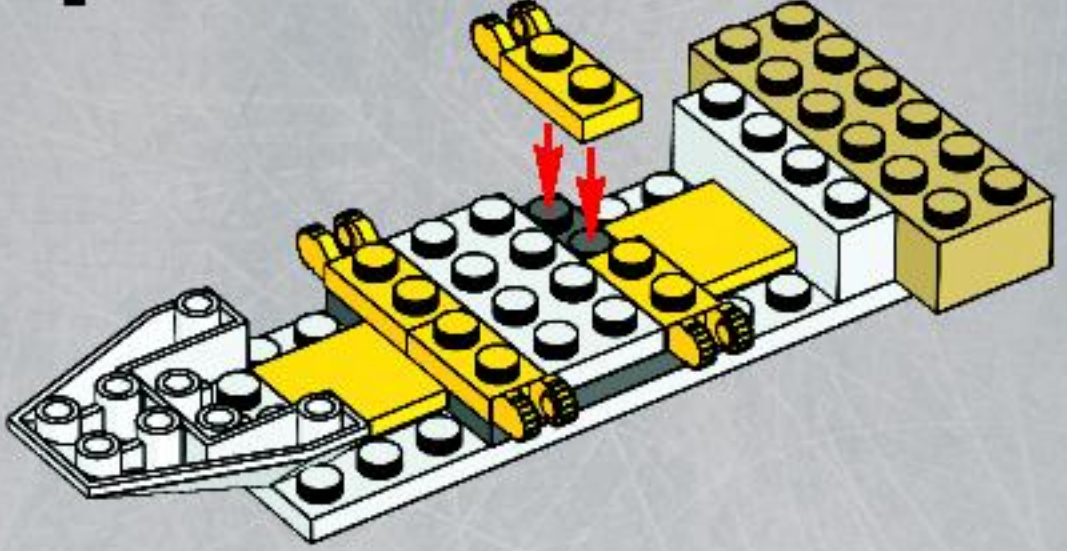

3

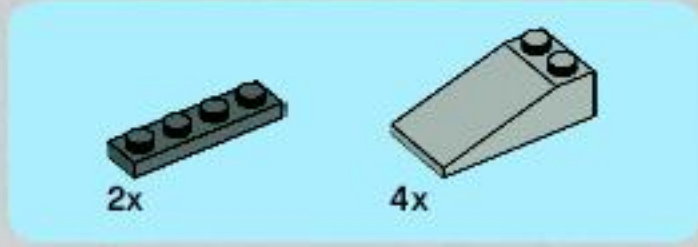
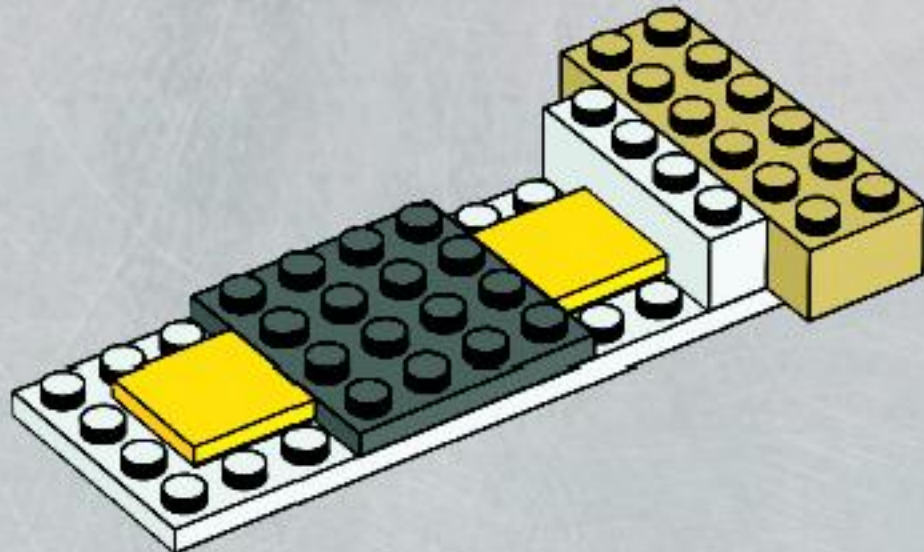

5

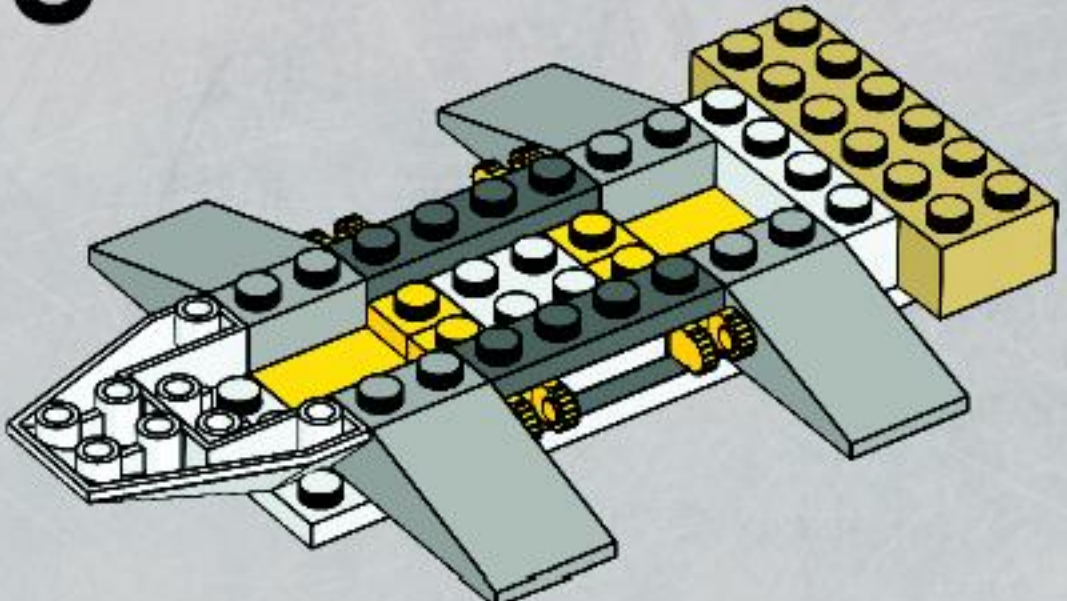

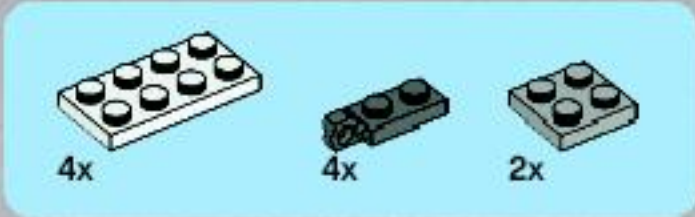

6

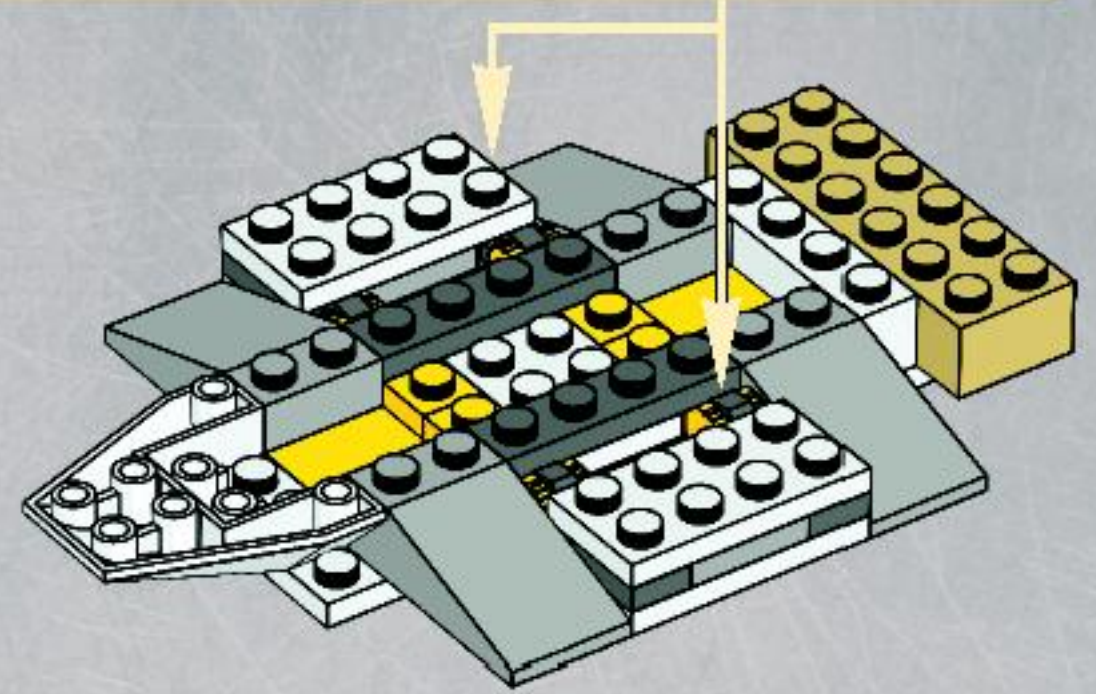
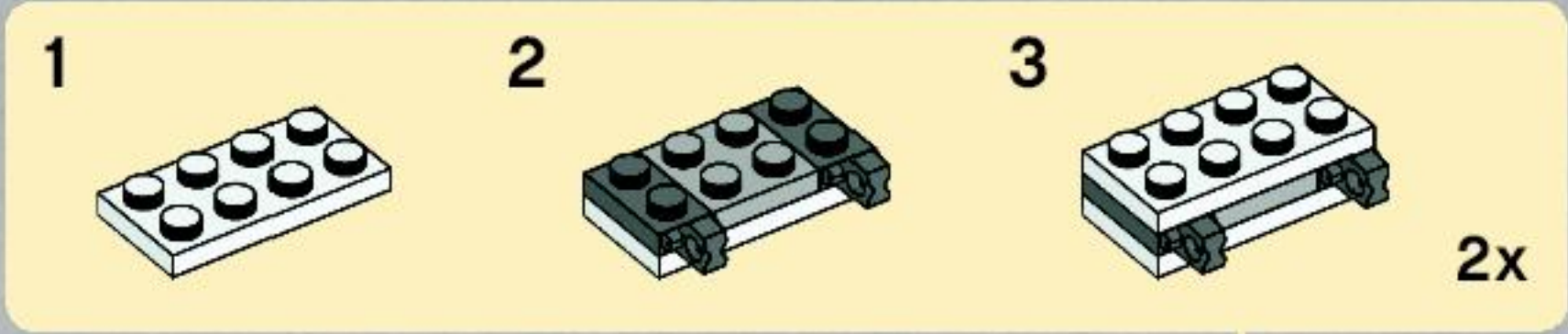

7

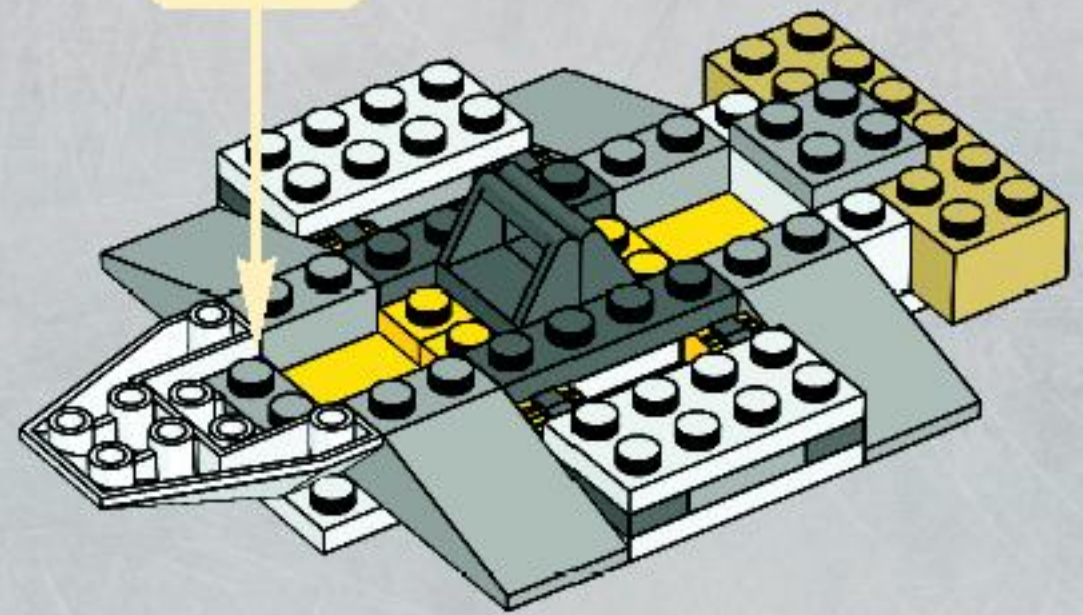



2x



3x

8

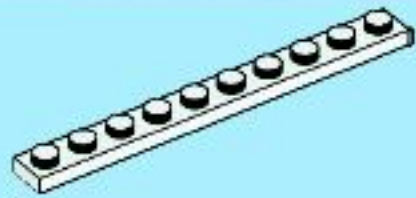
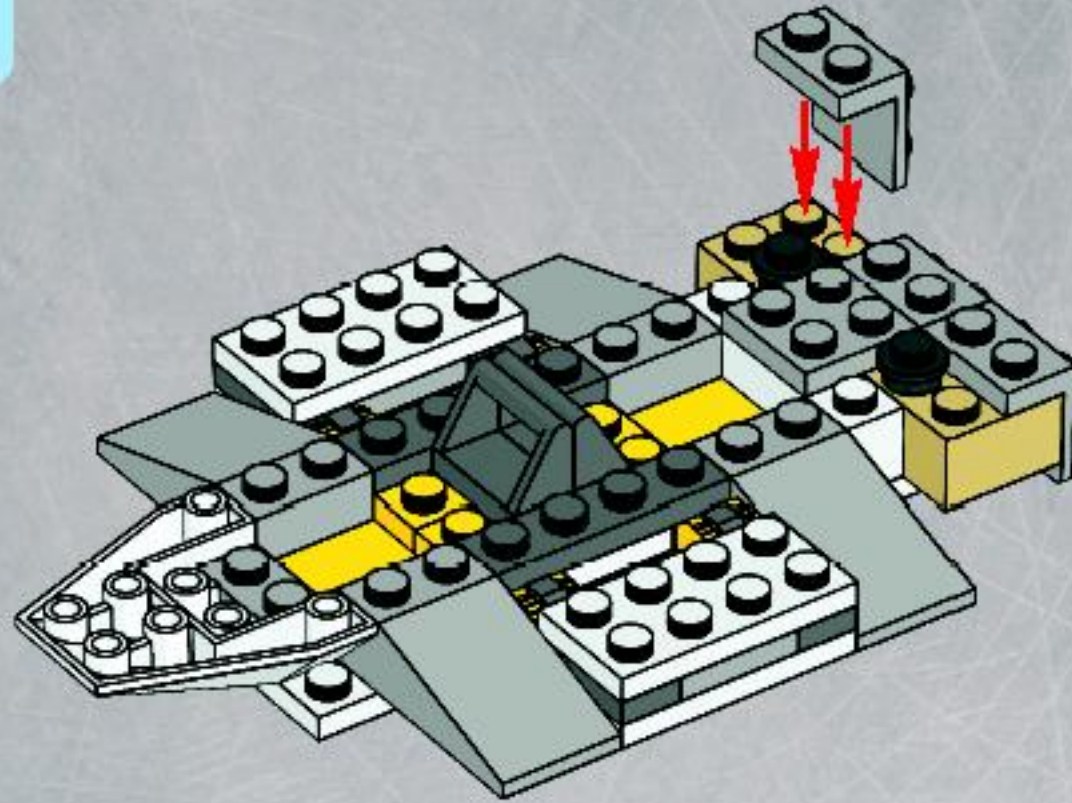

2x

9

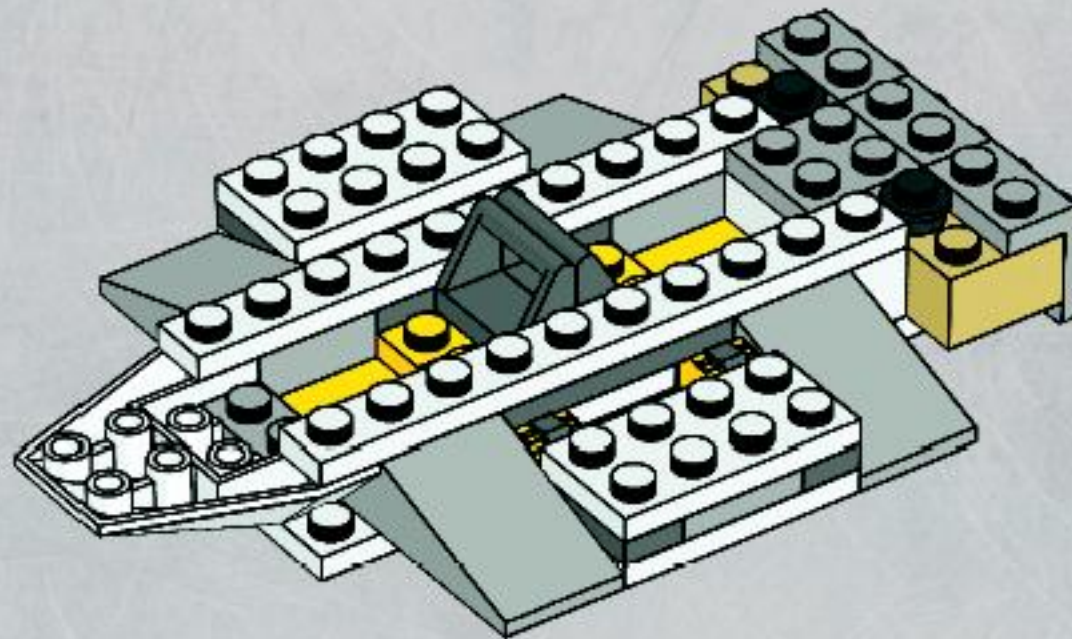



1x



2x

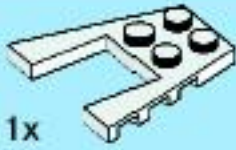

1x

10

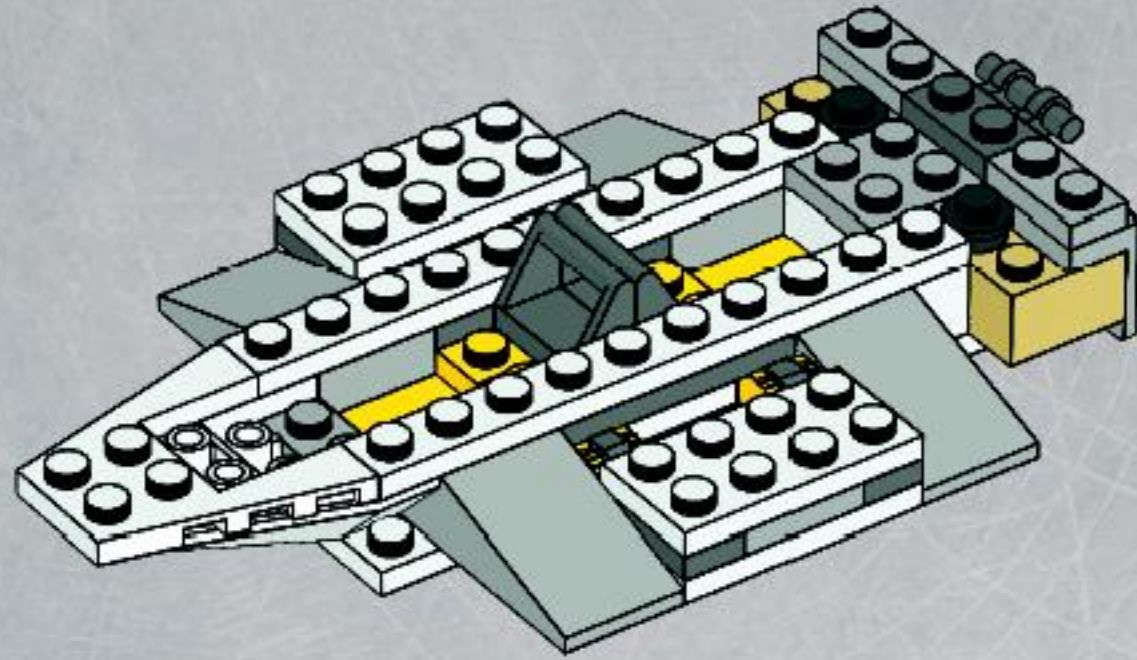

1x



1x



2x



1x

11

1



2

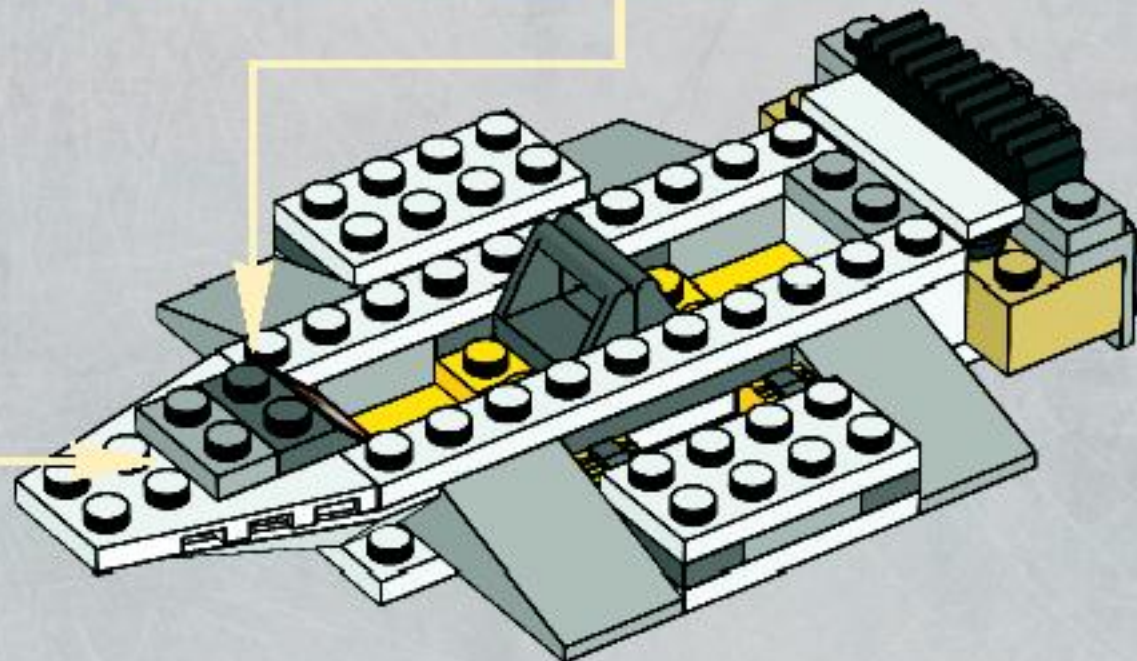
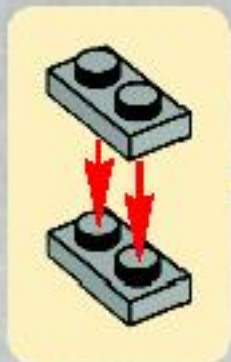
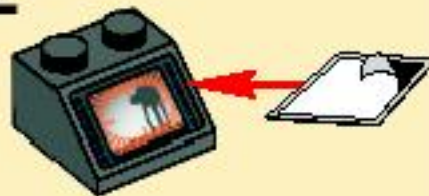



2x

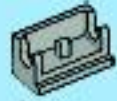

2x

12

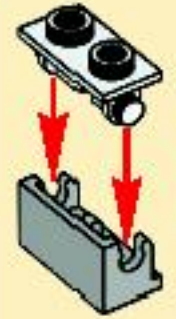
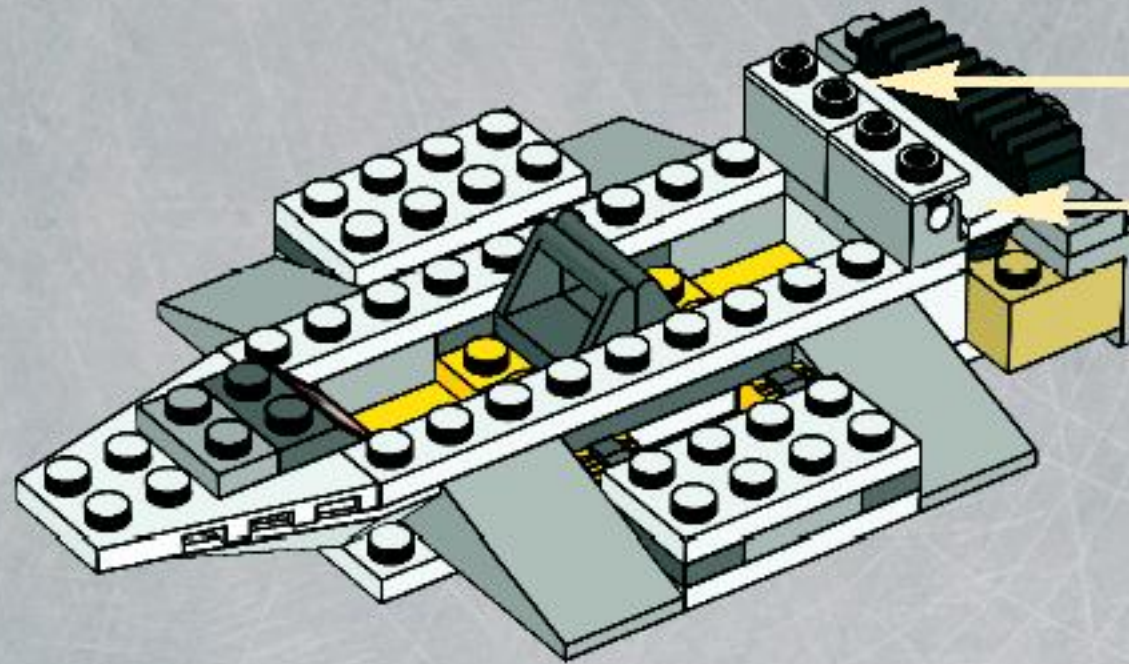

2x



2x

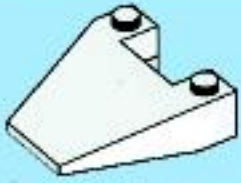

1x

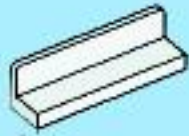

4x

13

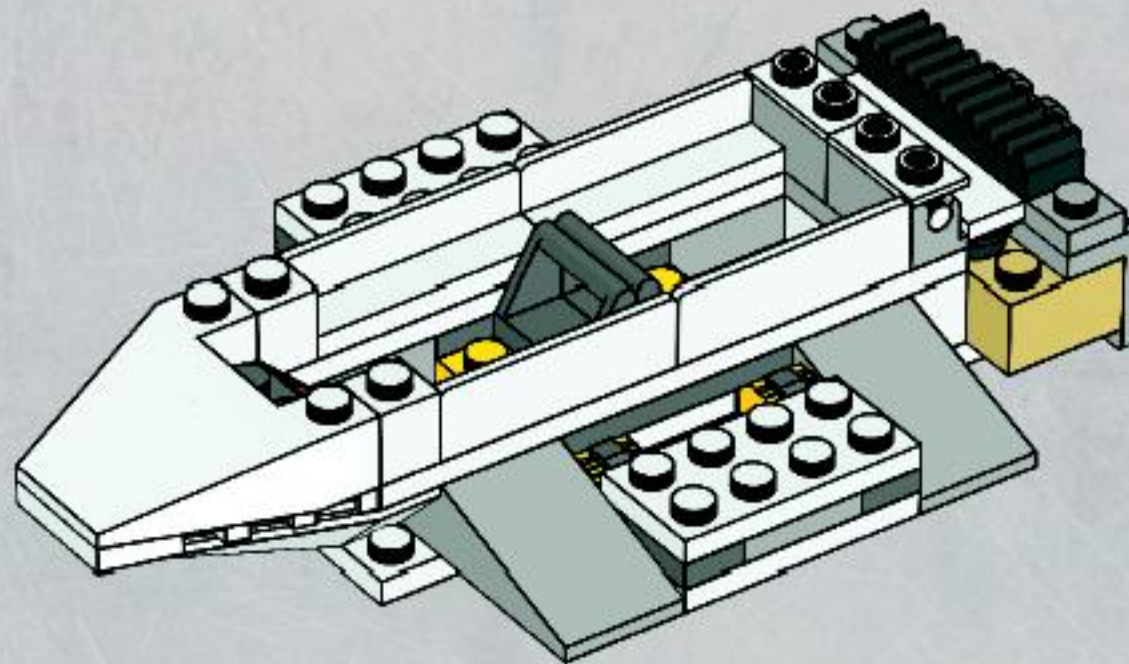



2x

14

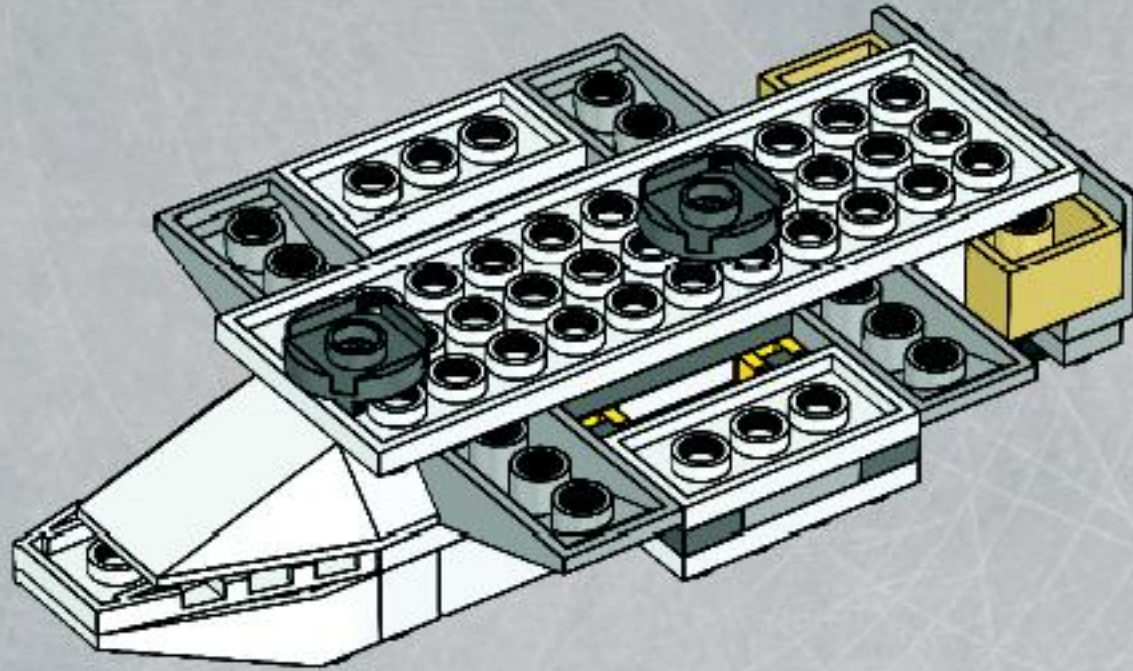

4x

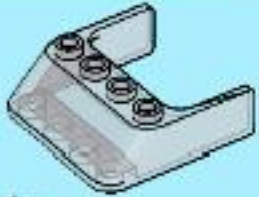

1x

15

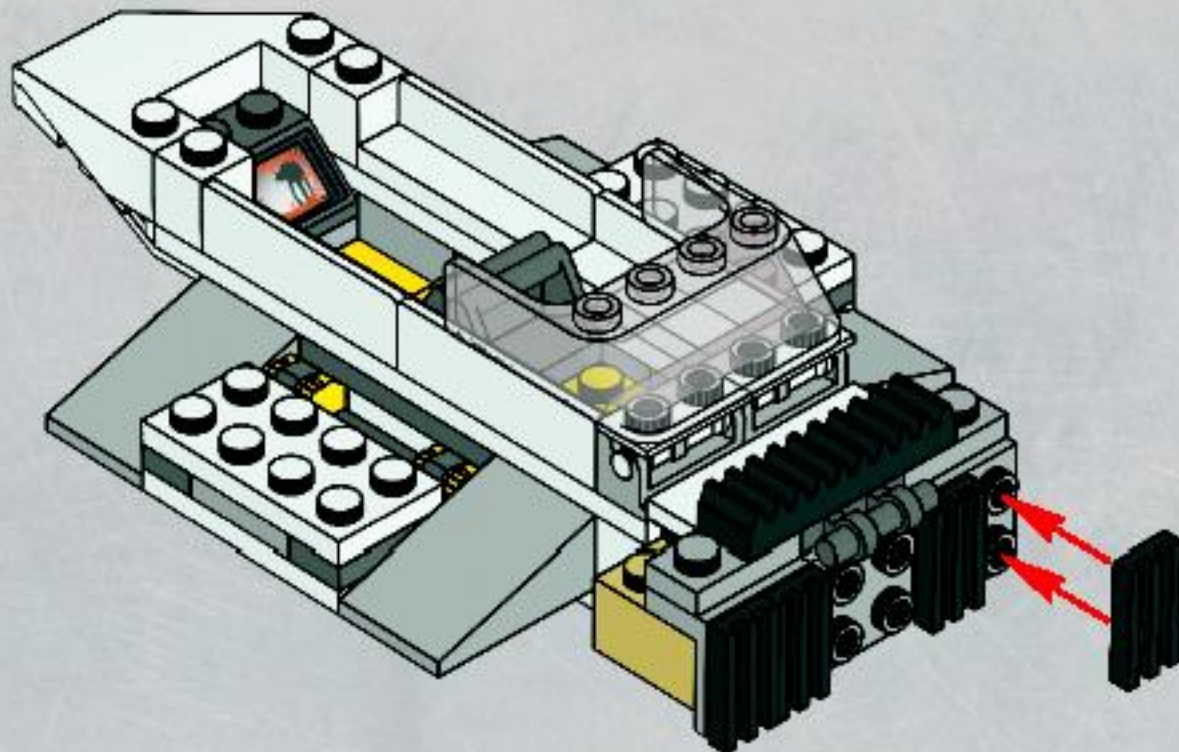



1x



1x

16

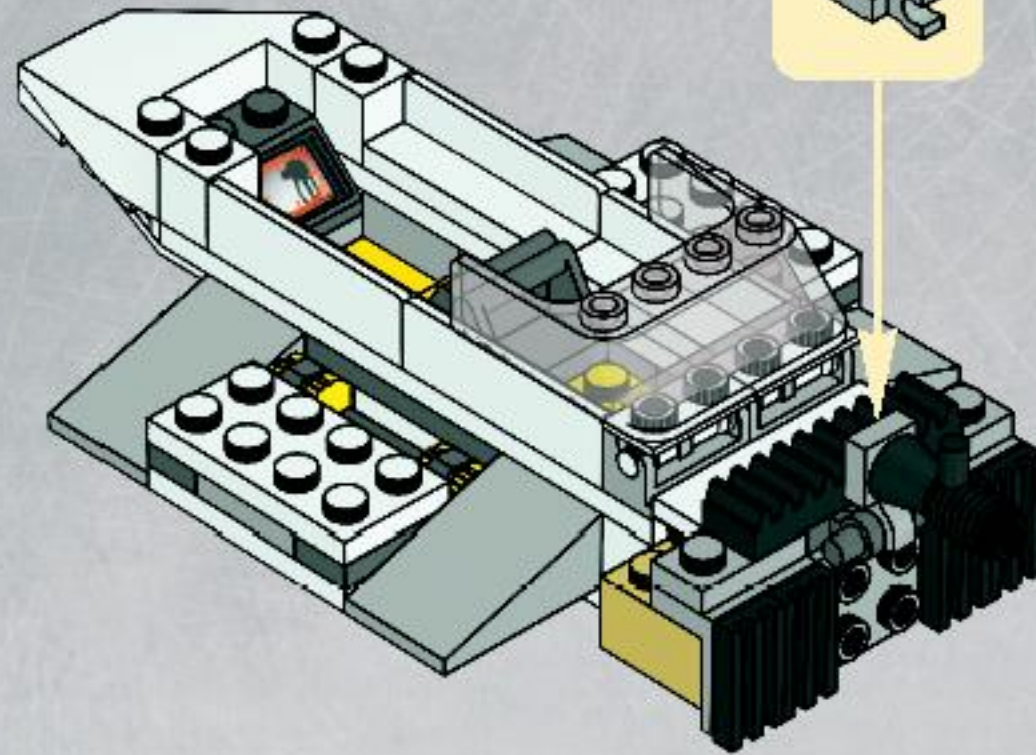

17

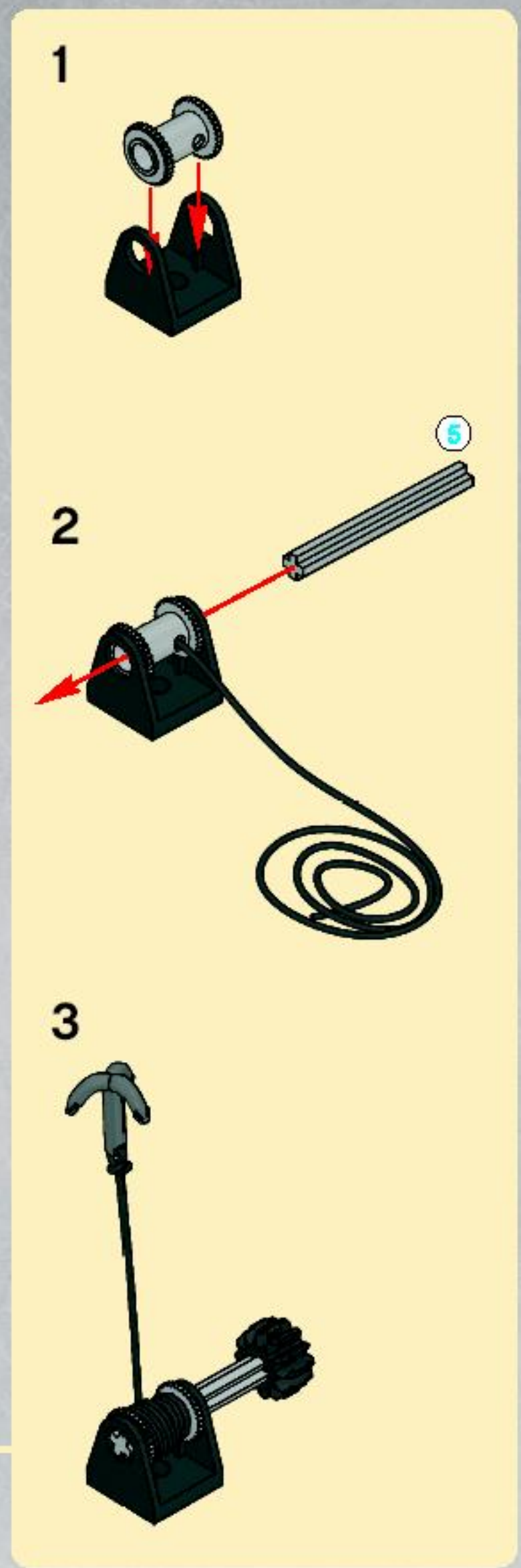
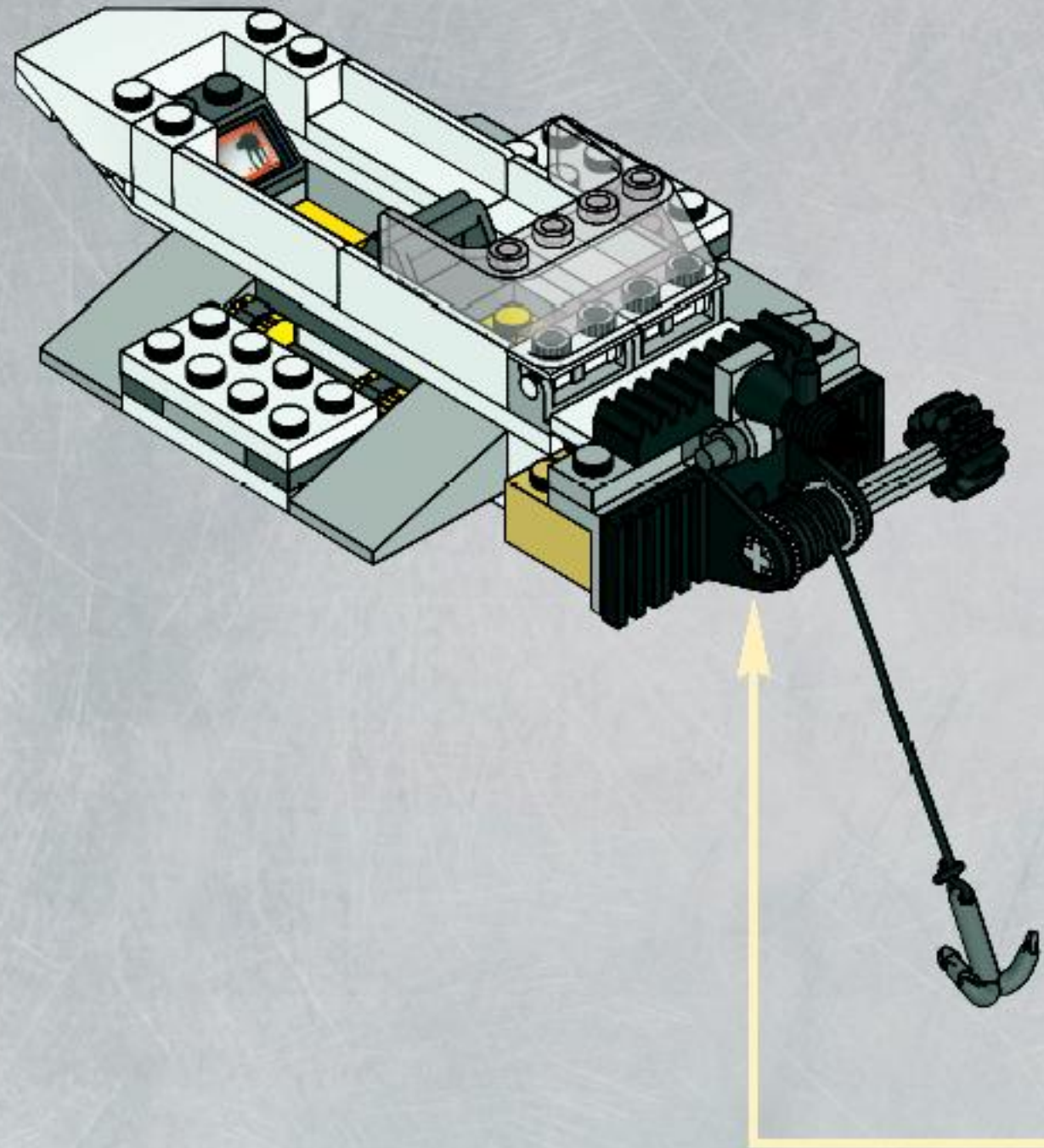

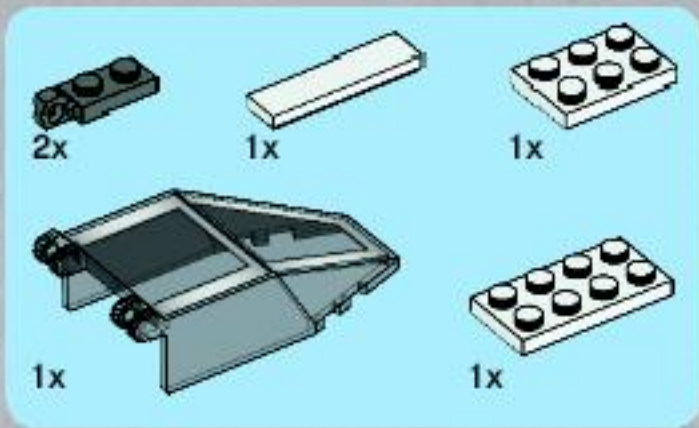

18

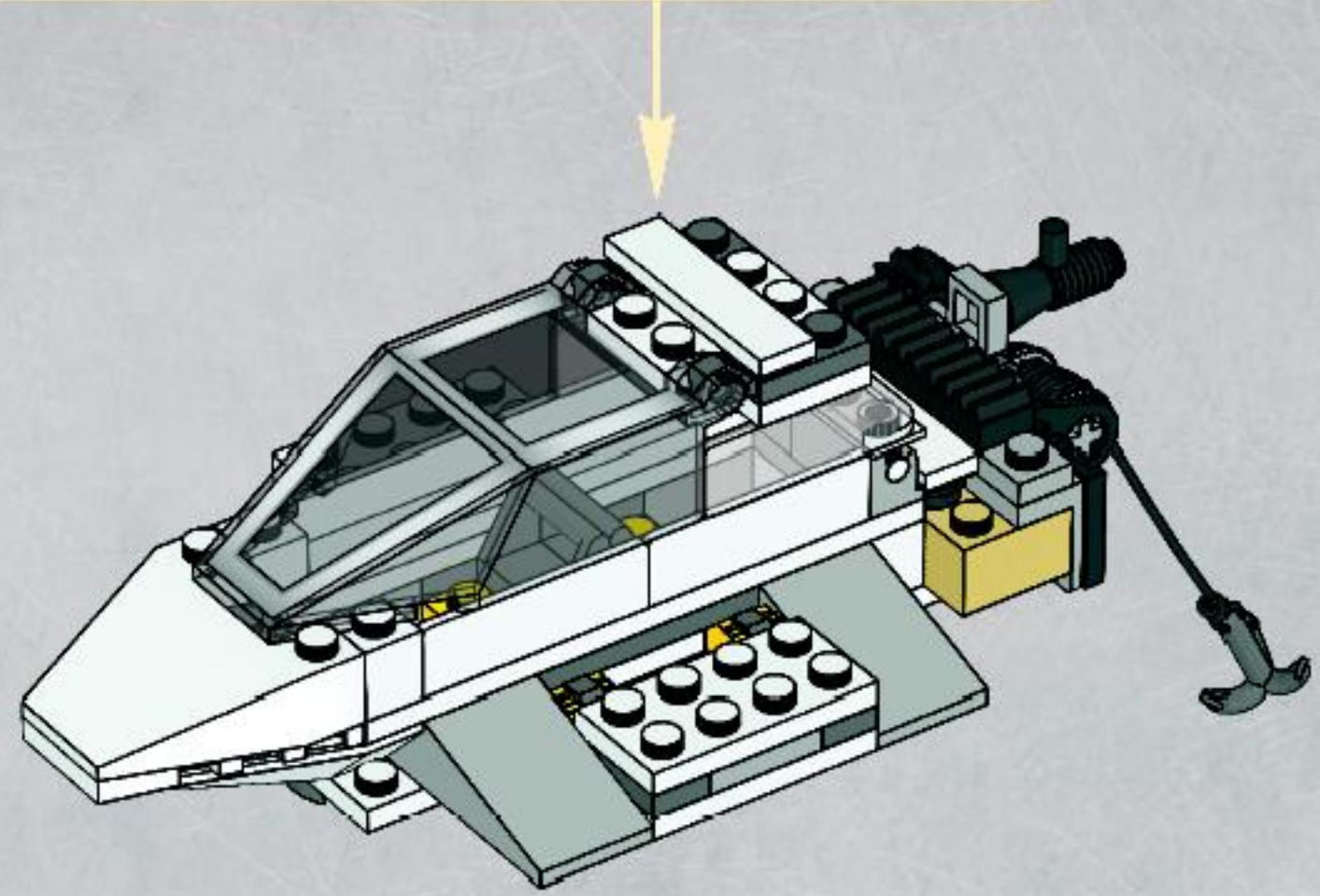
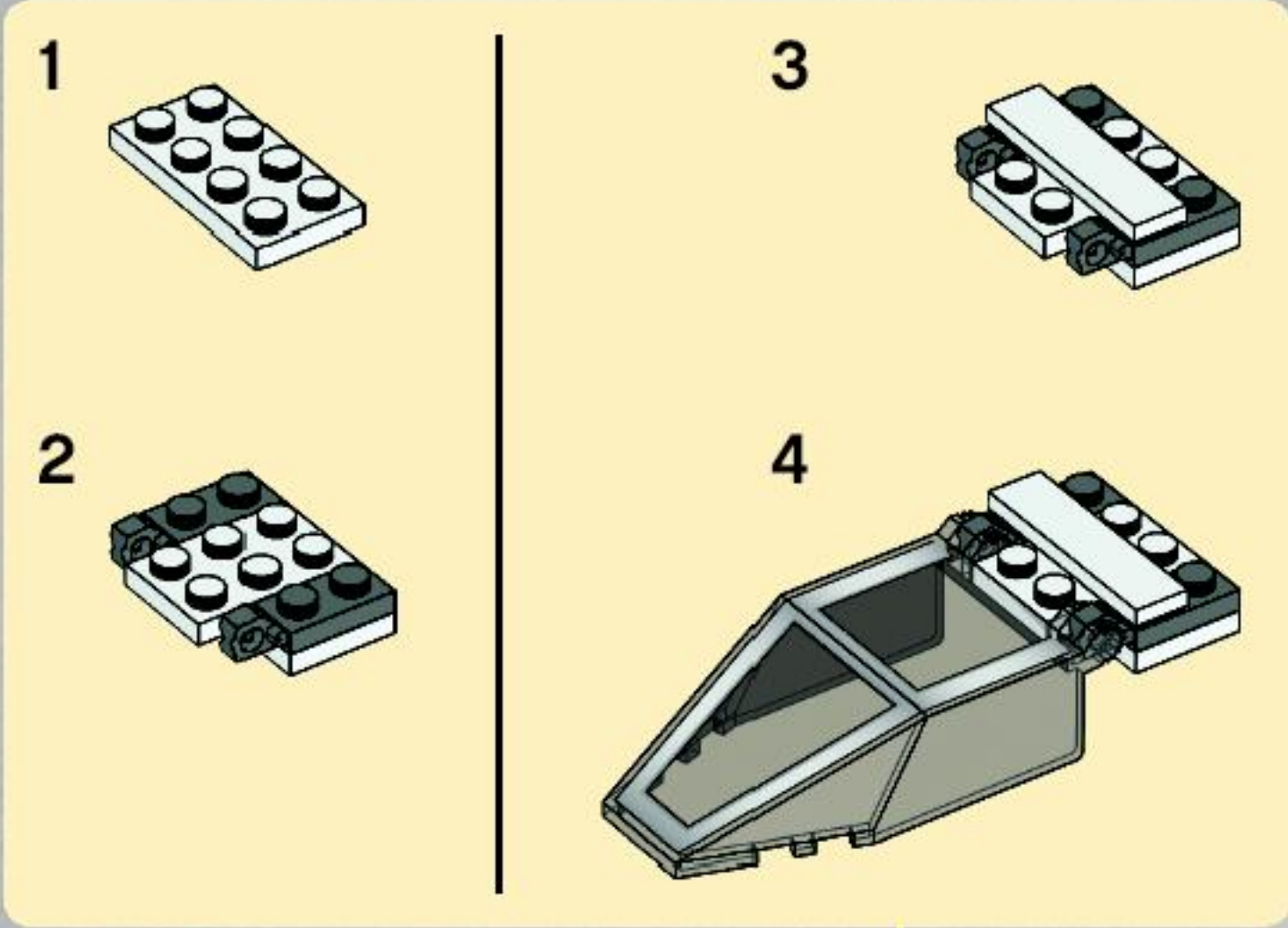

19

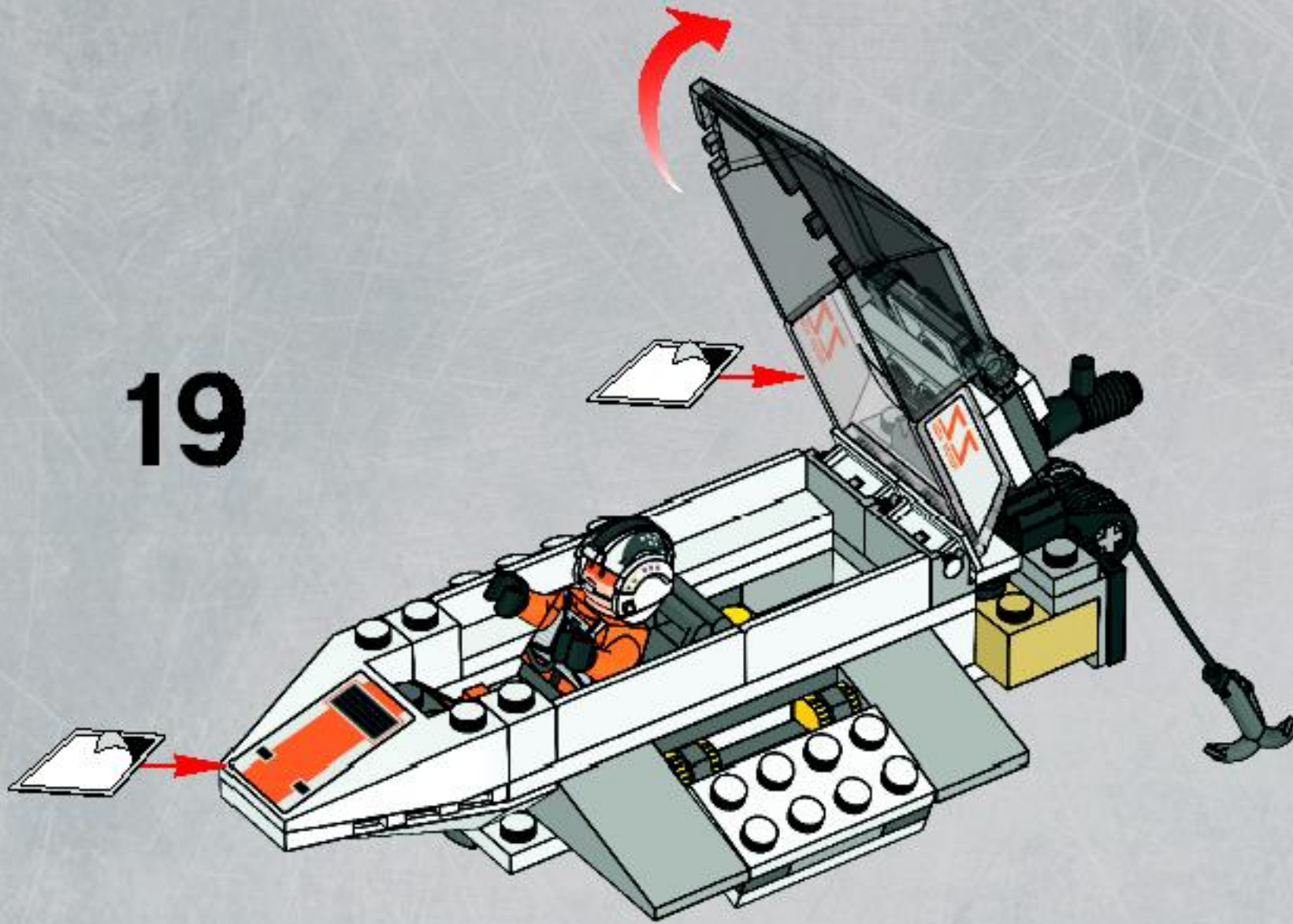

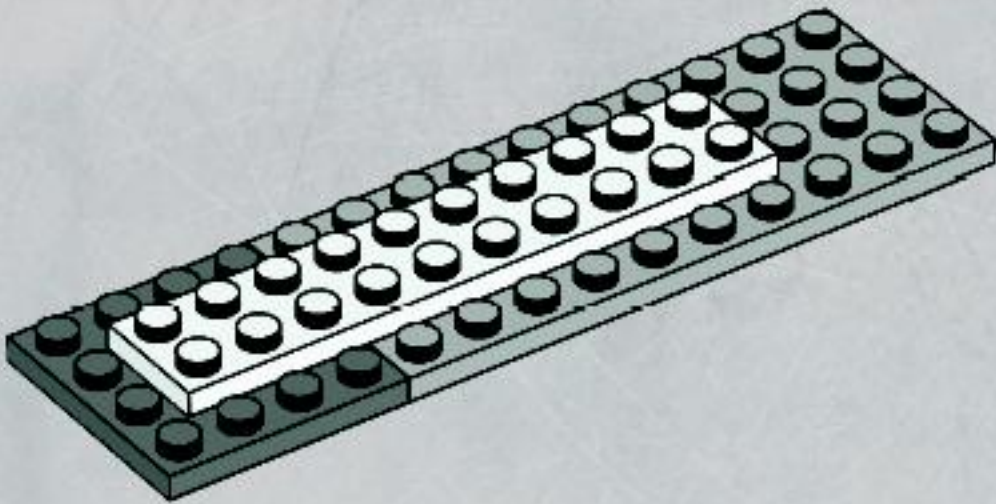
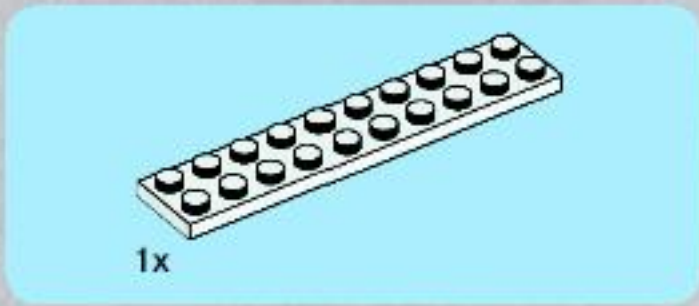
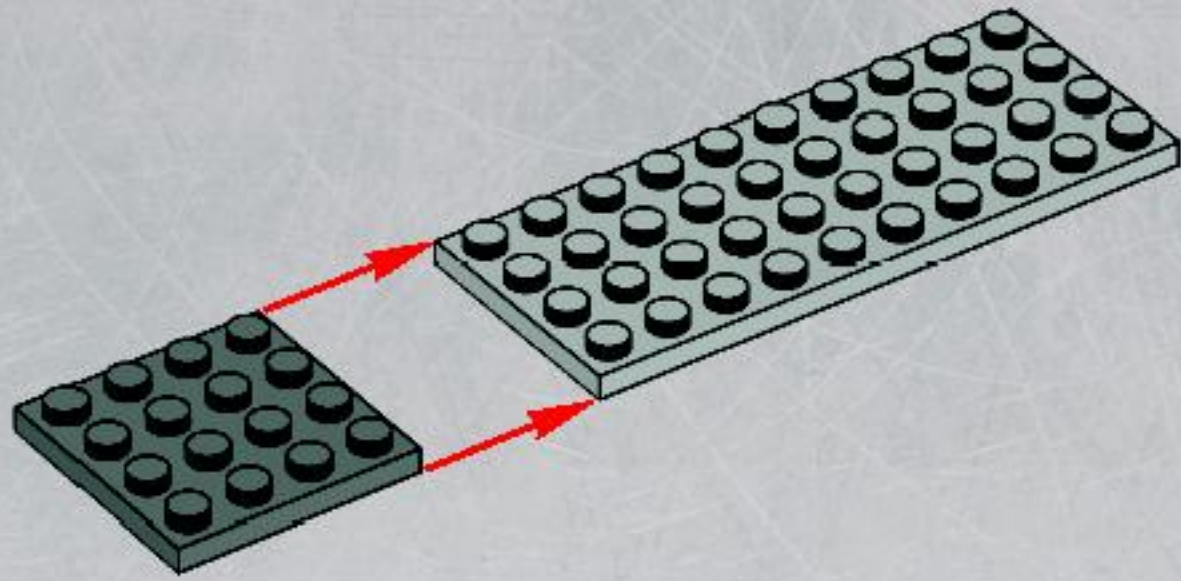
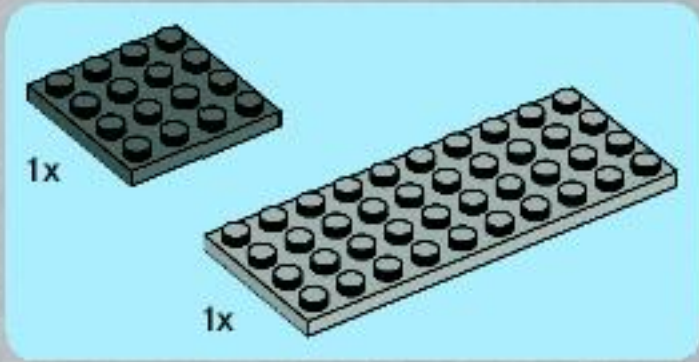
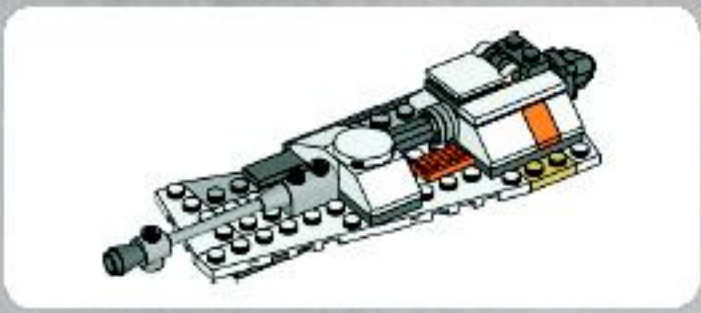
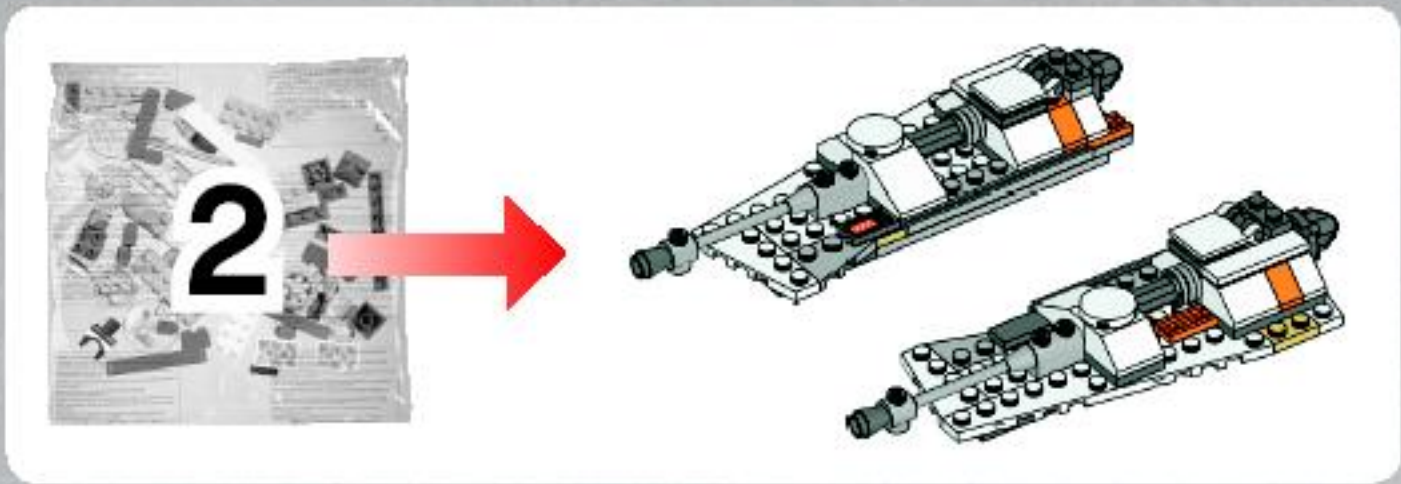

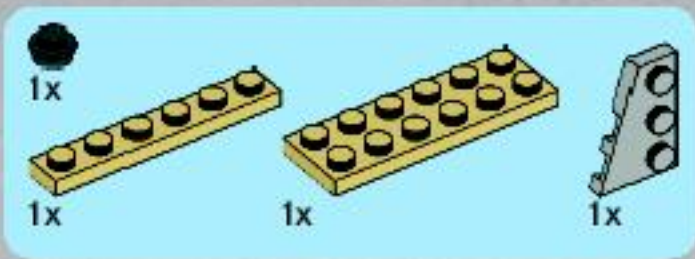

3

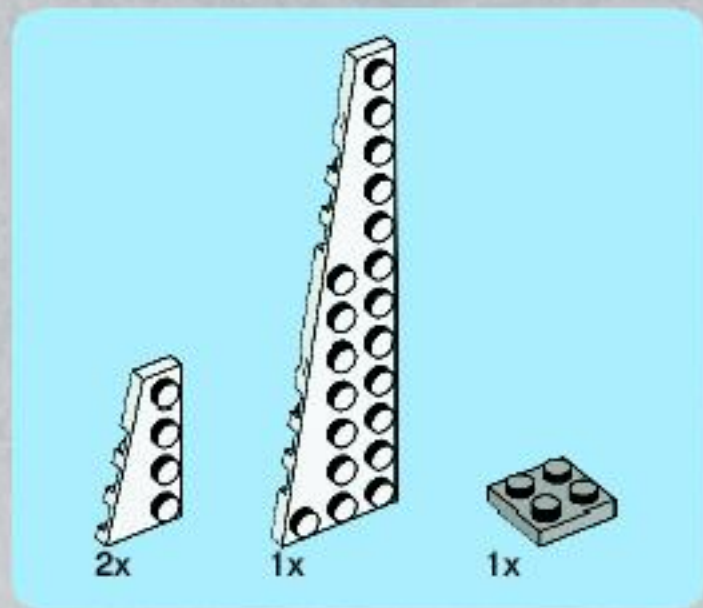
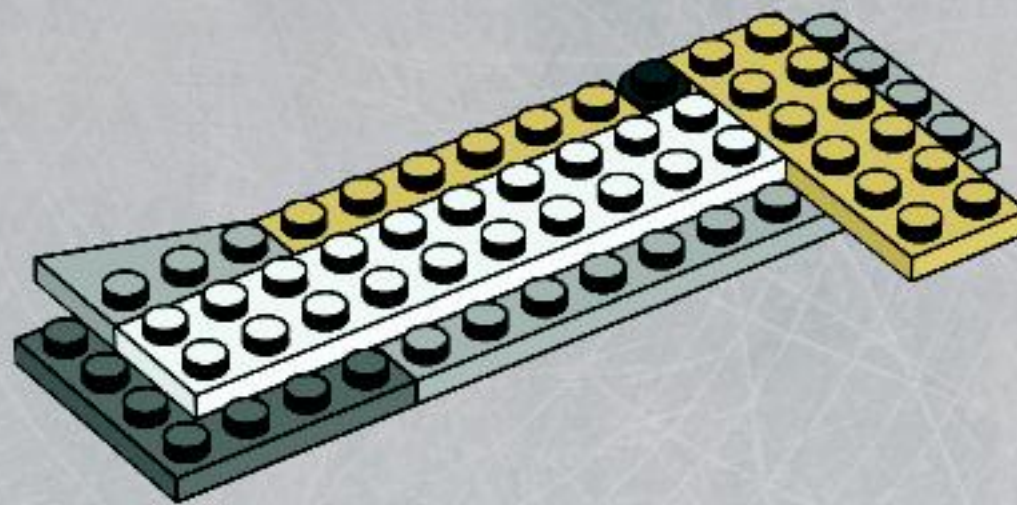

4

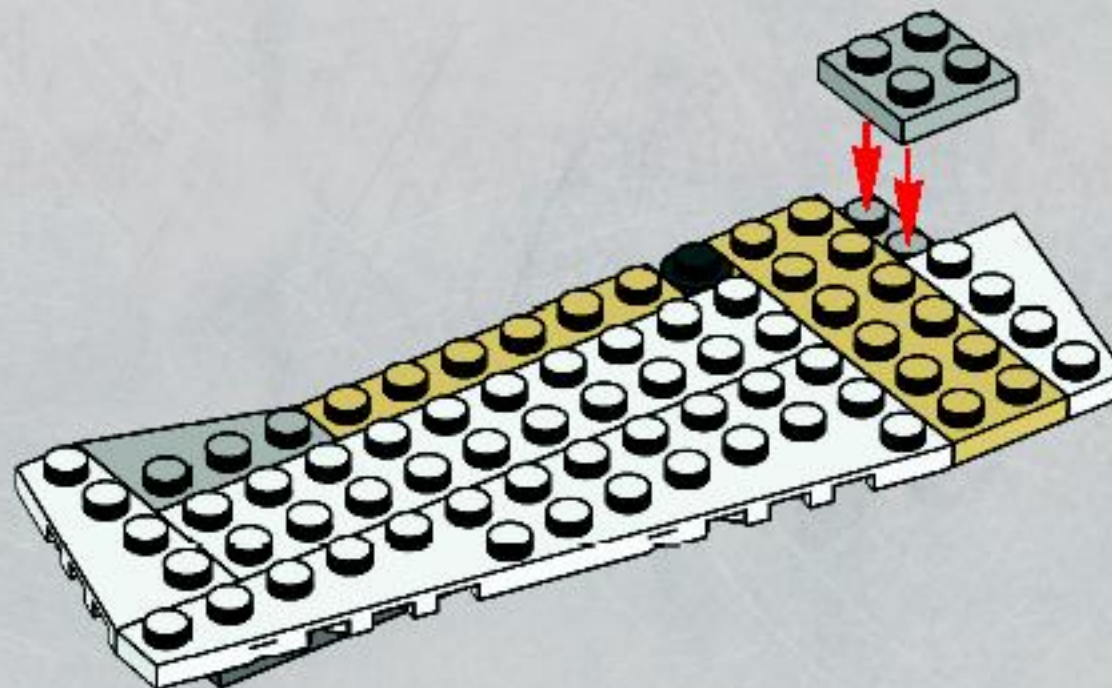

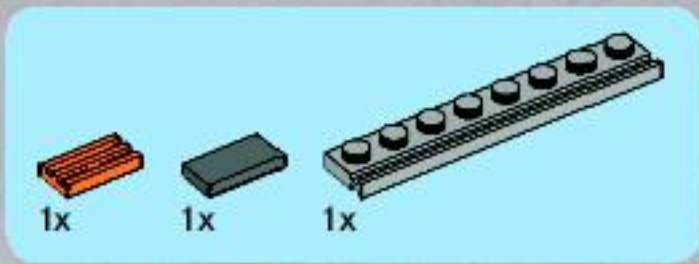

5

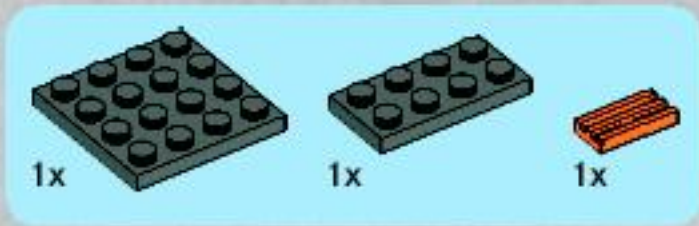
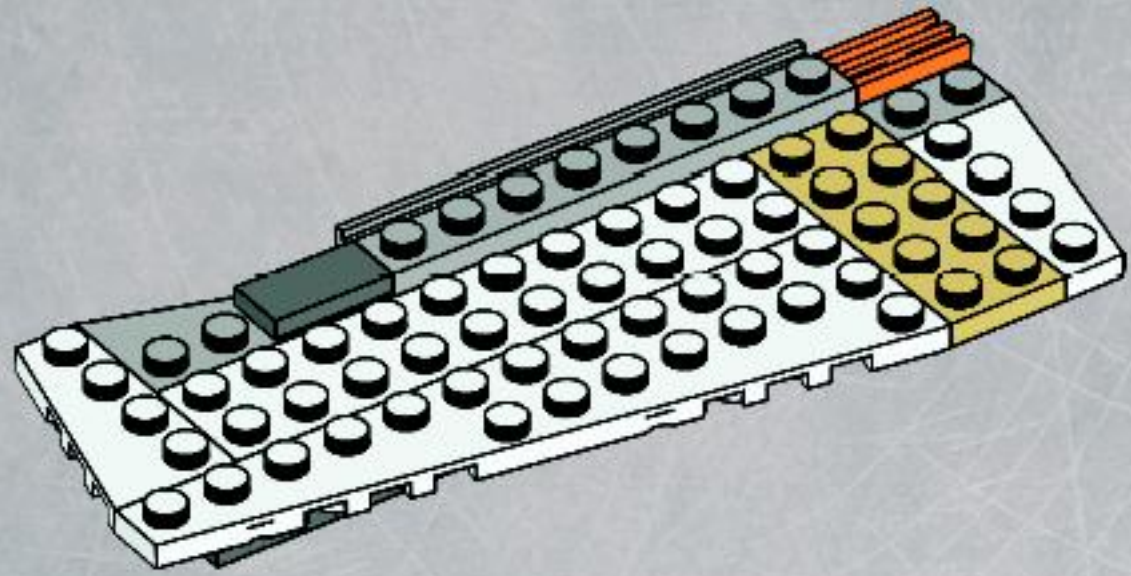

6

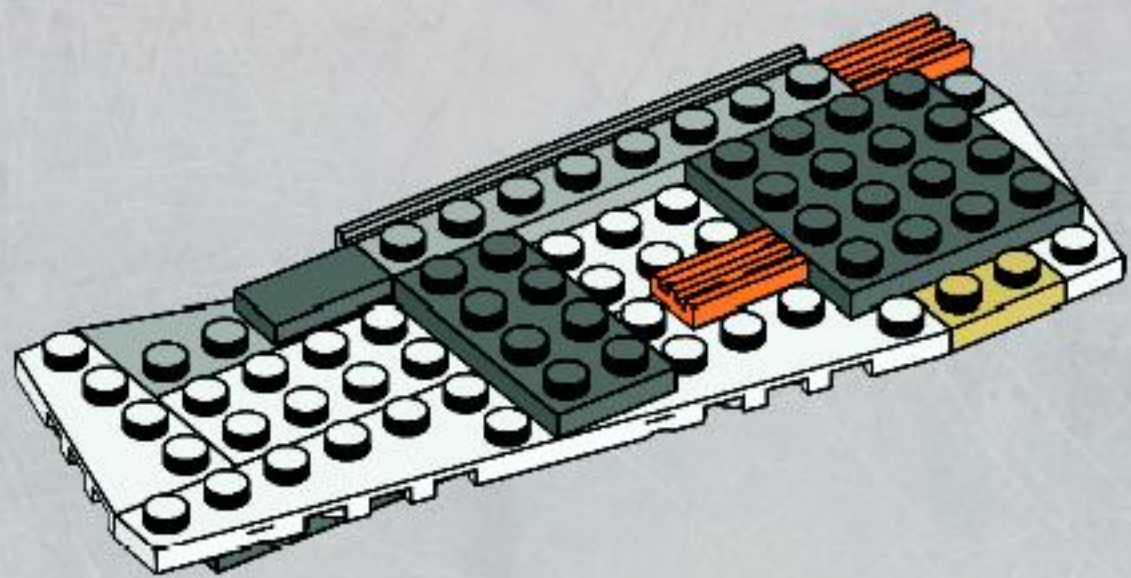



2x



1x

7

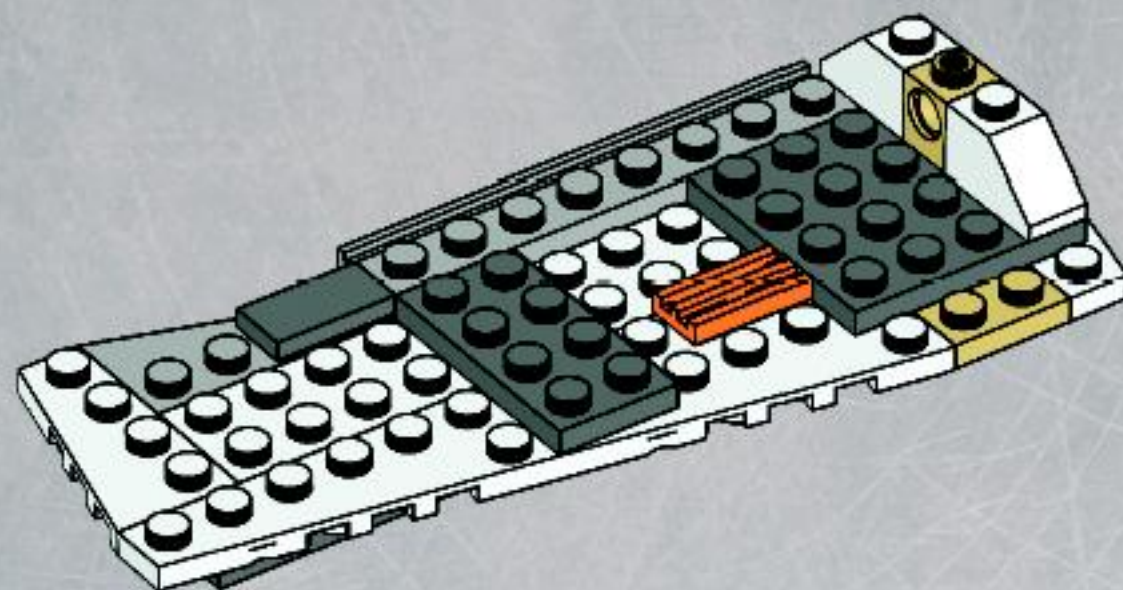

2x



2x



1x

8

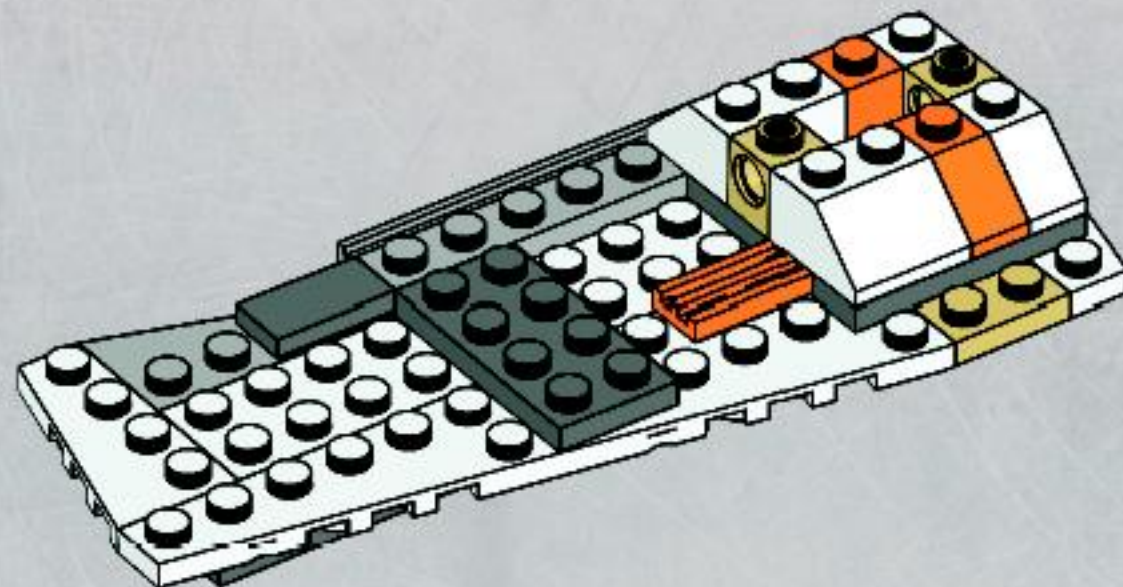

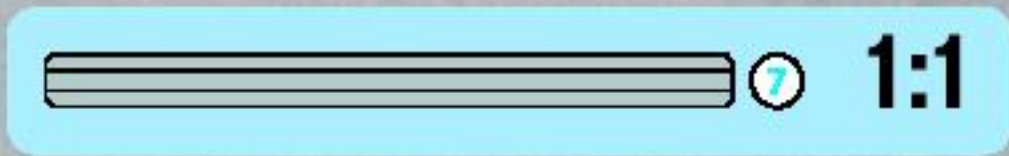
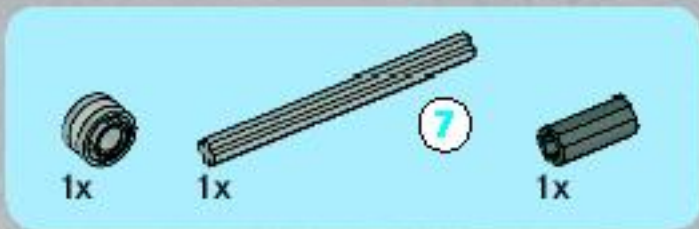

9

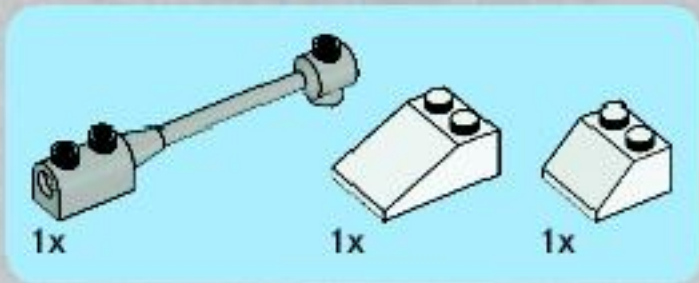
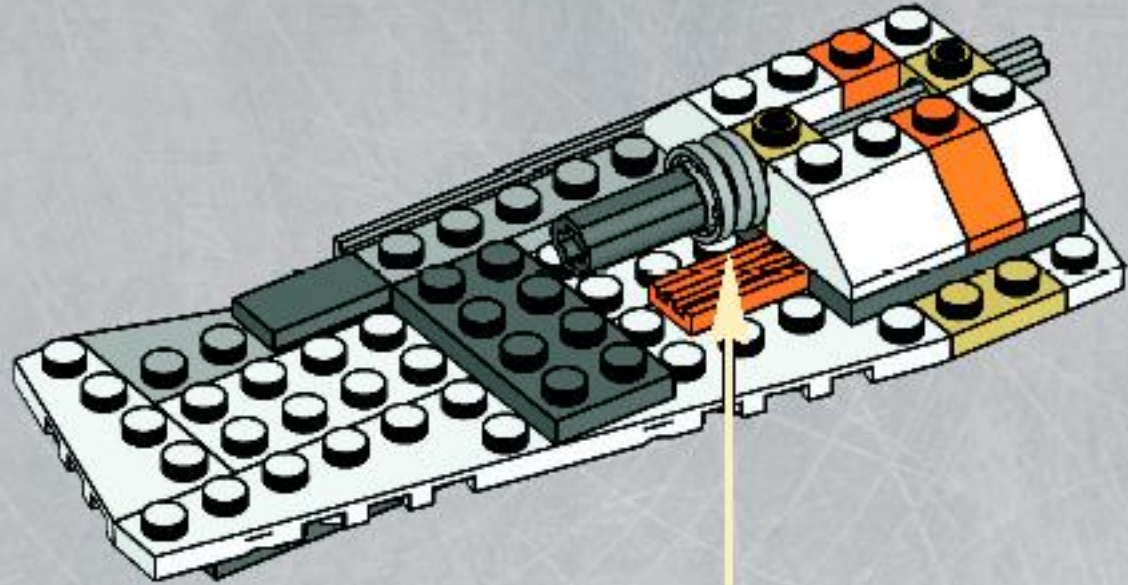
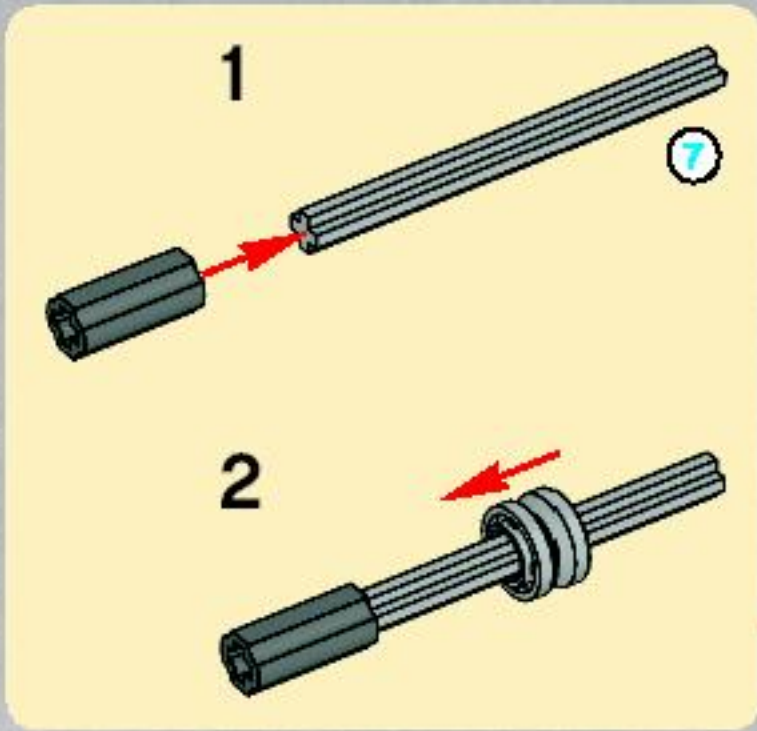

10

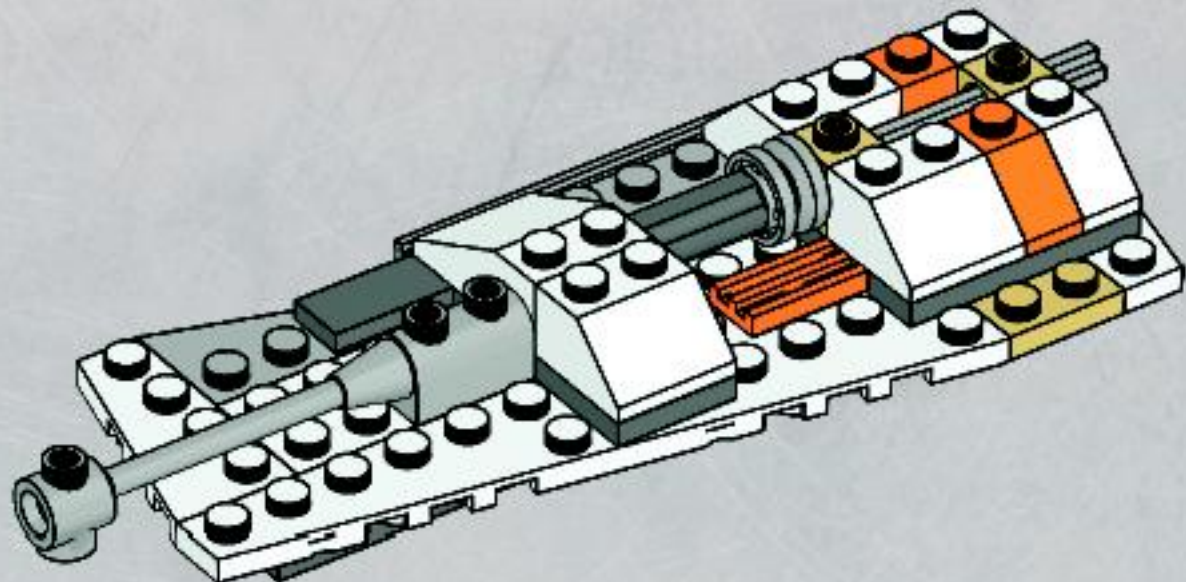

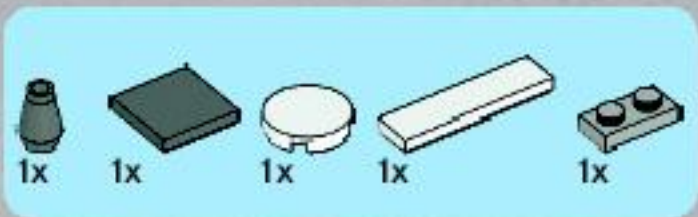

11

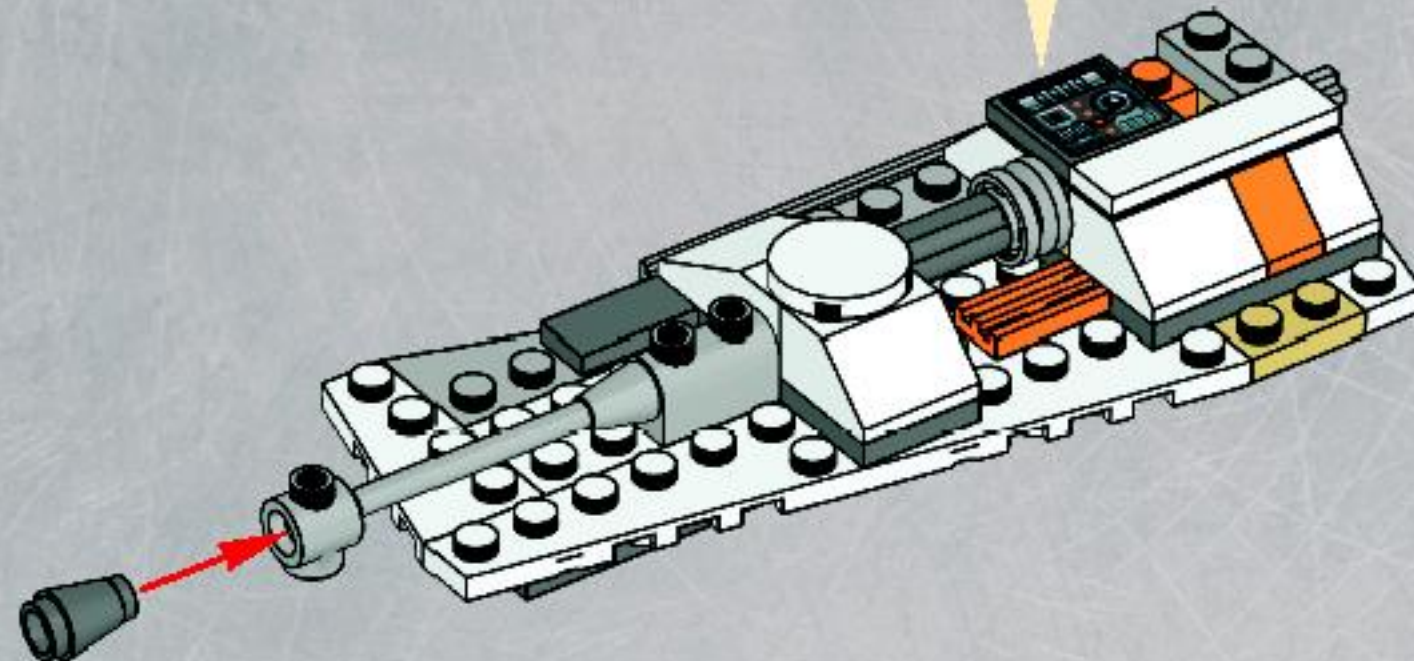

12

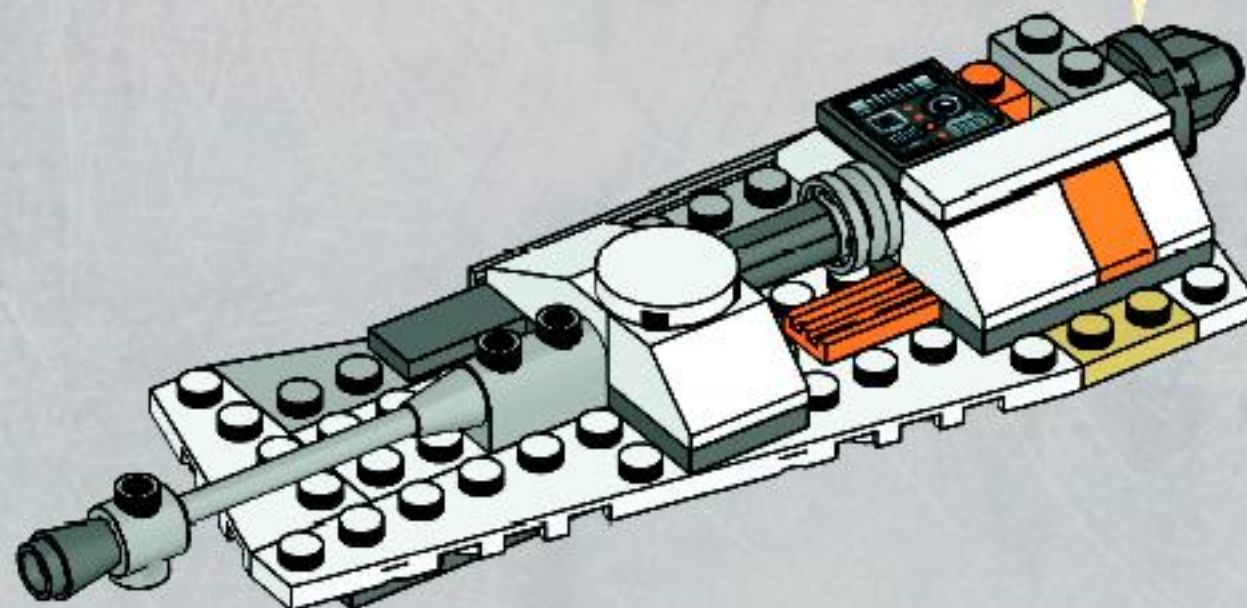
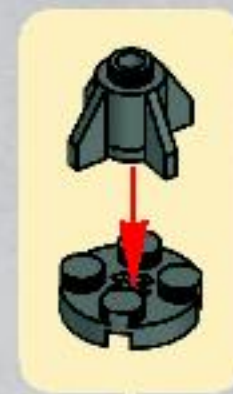



1x

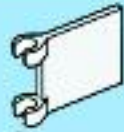

1x

13

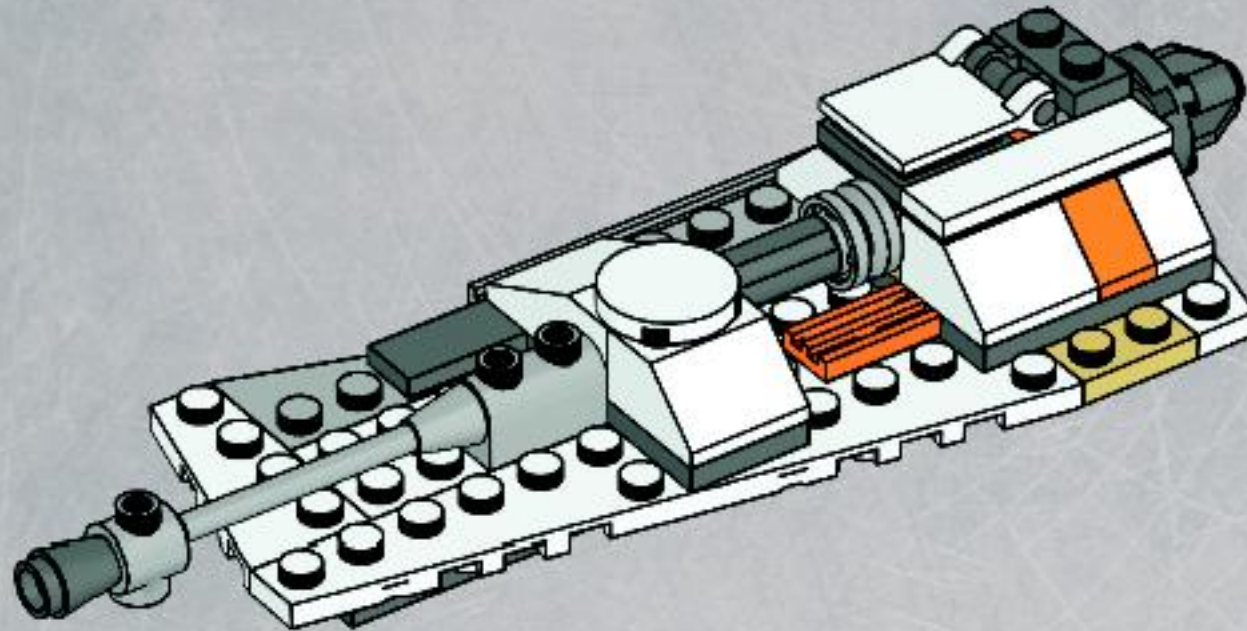
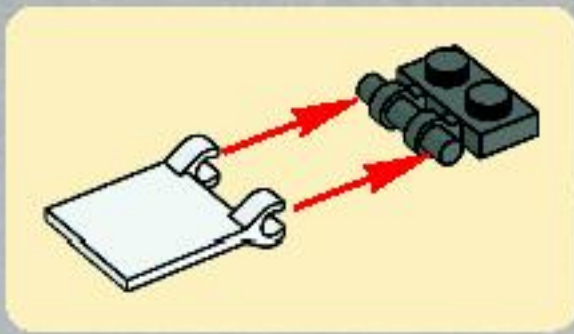

20

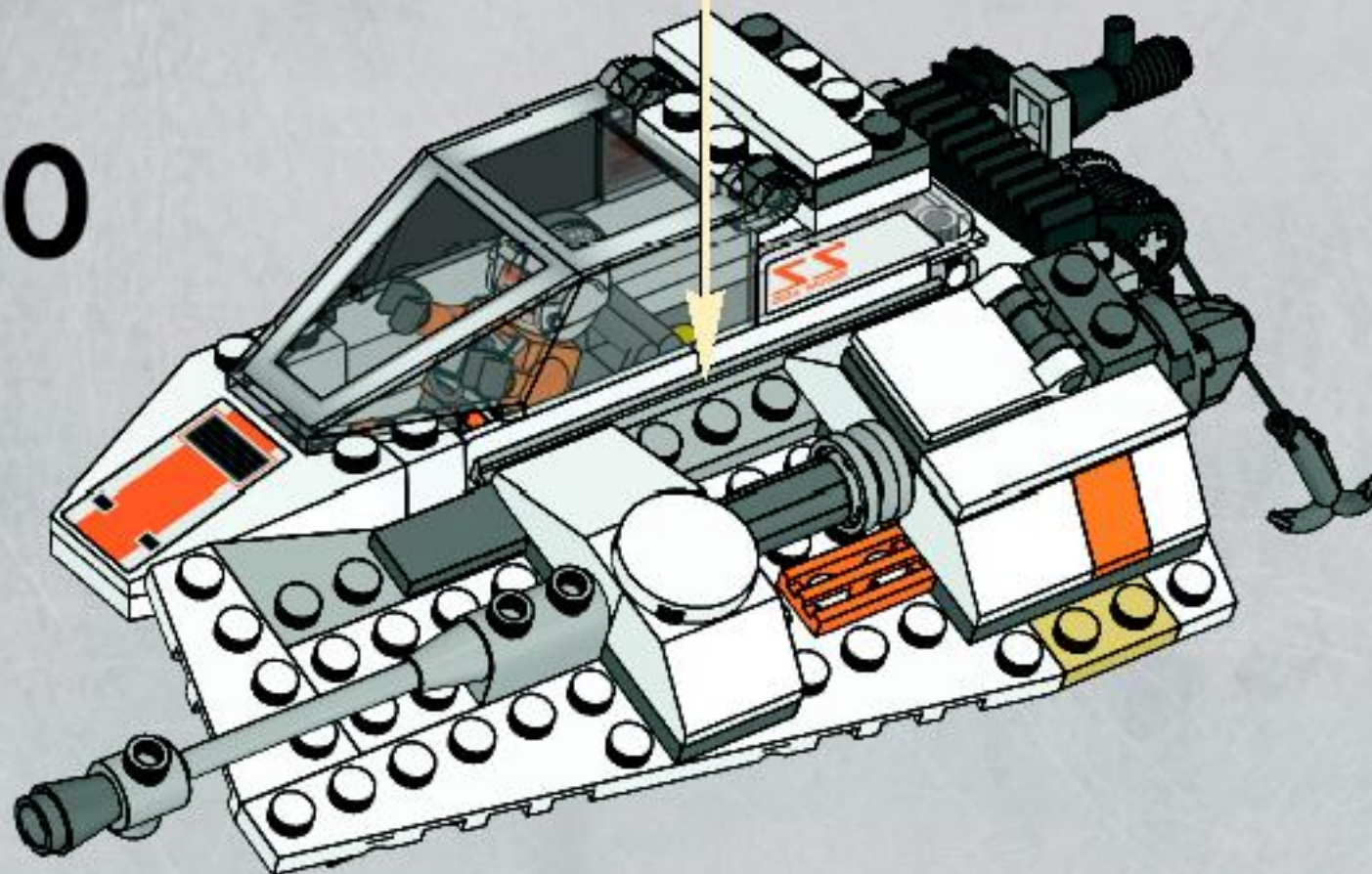

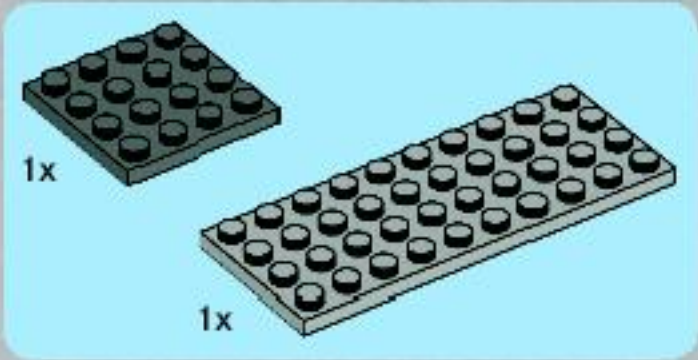
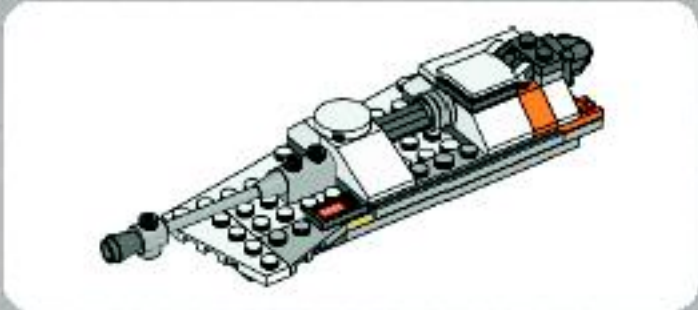

1

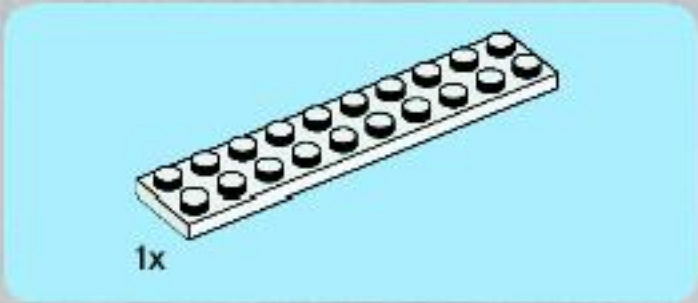
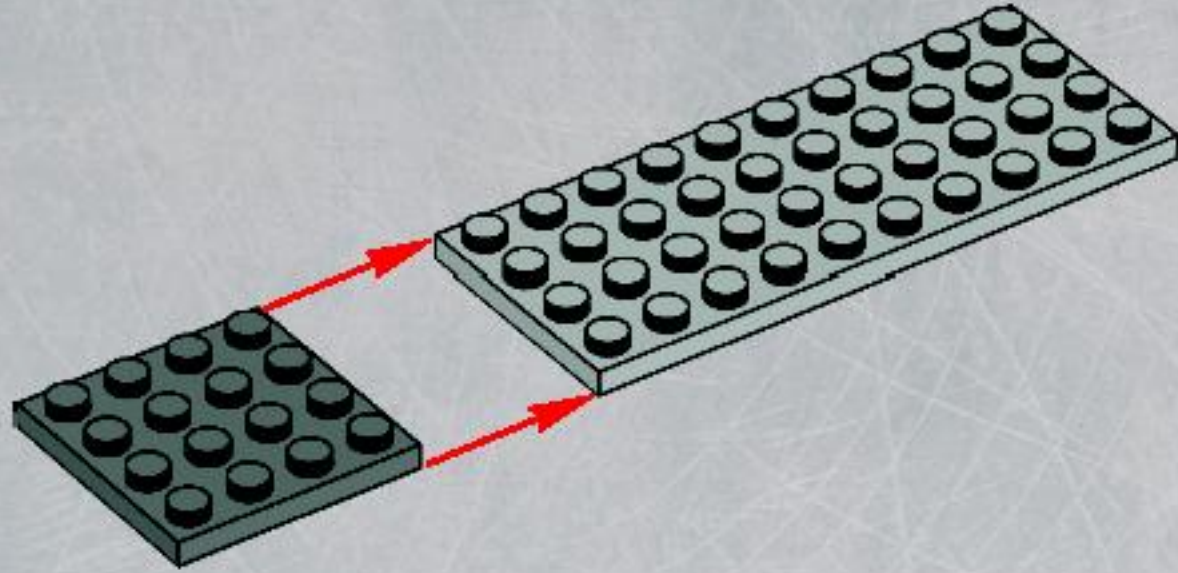

2

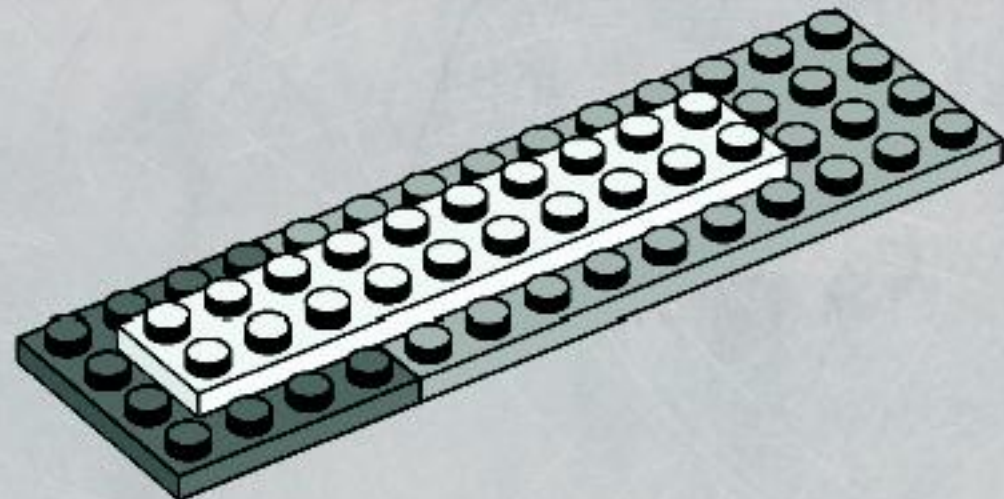

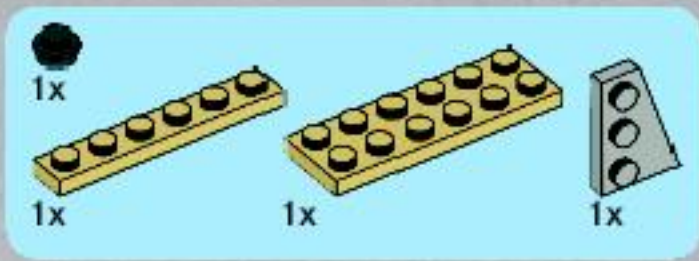

3

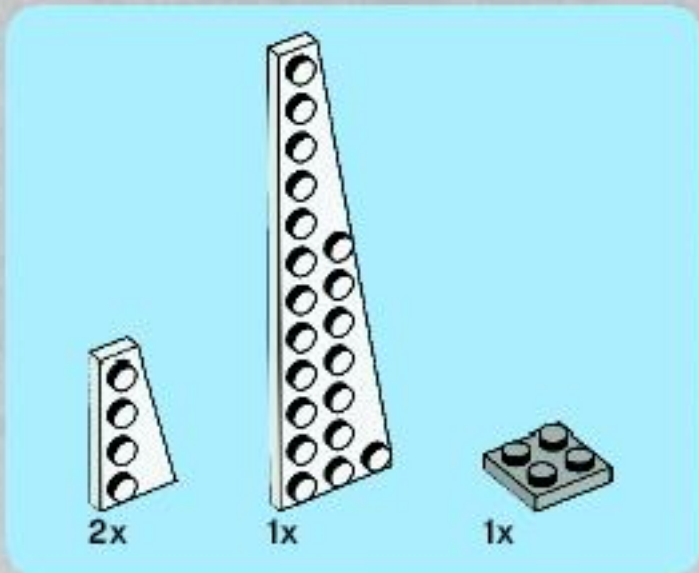
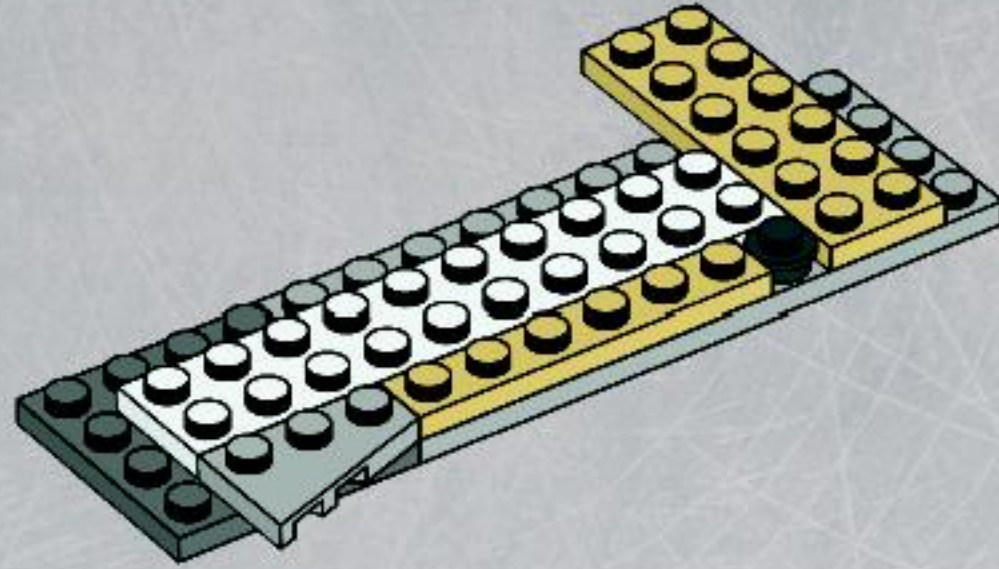

4

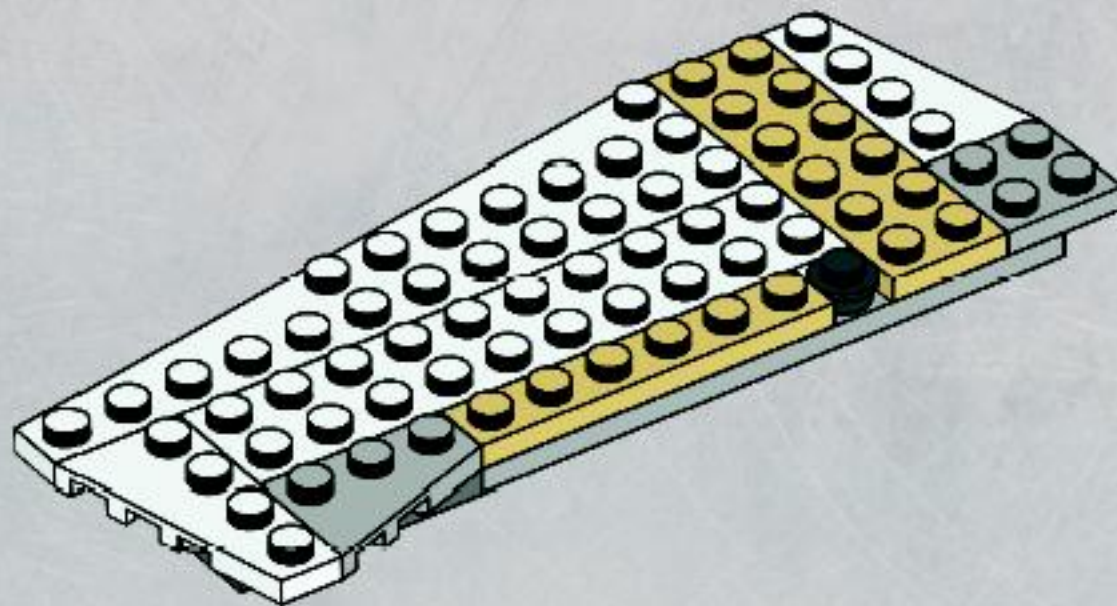

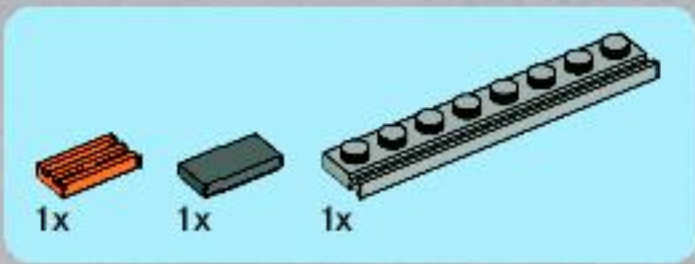

5

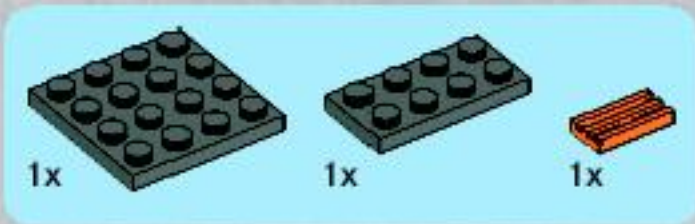
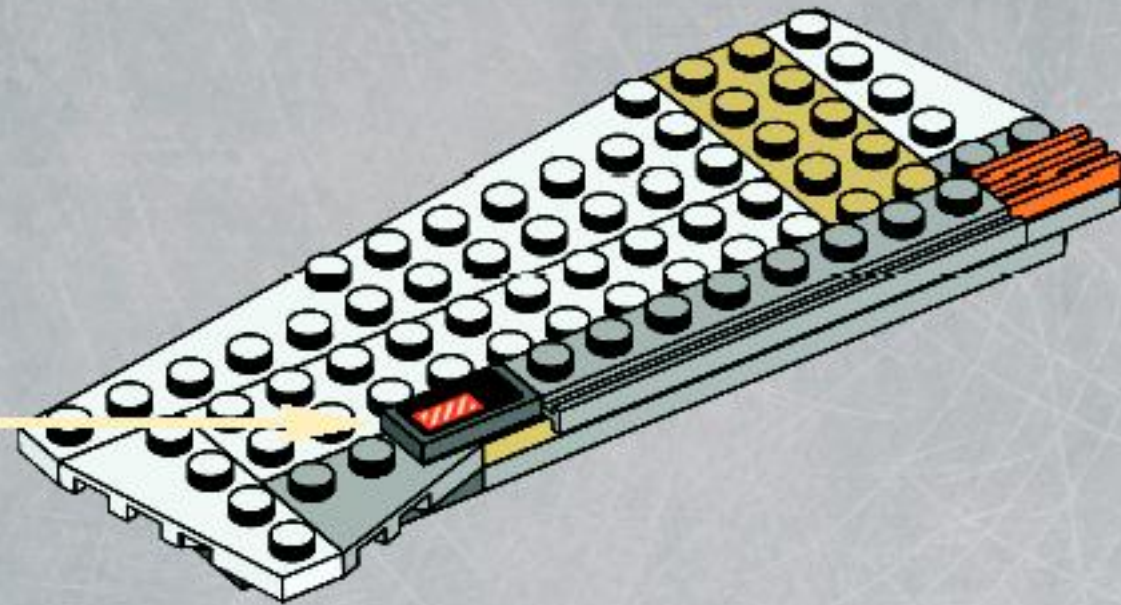
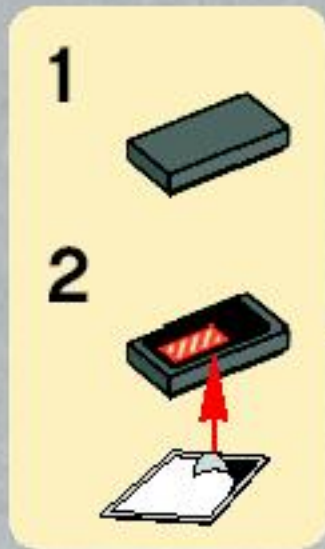

6

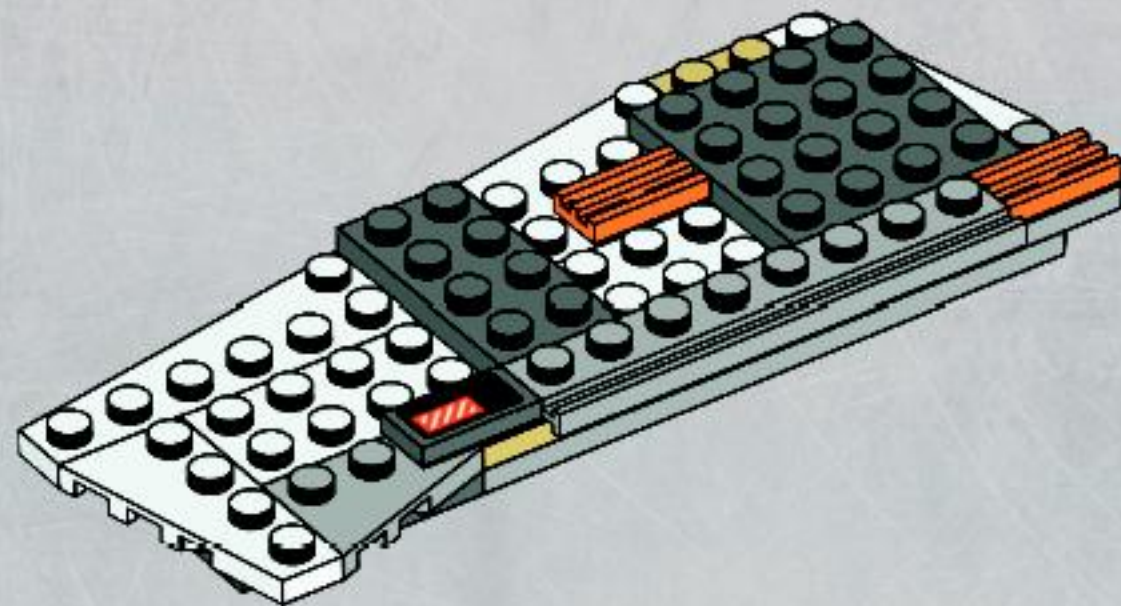



2x



1x

7

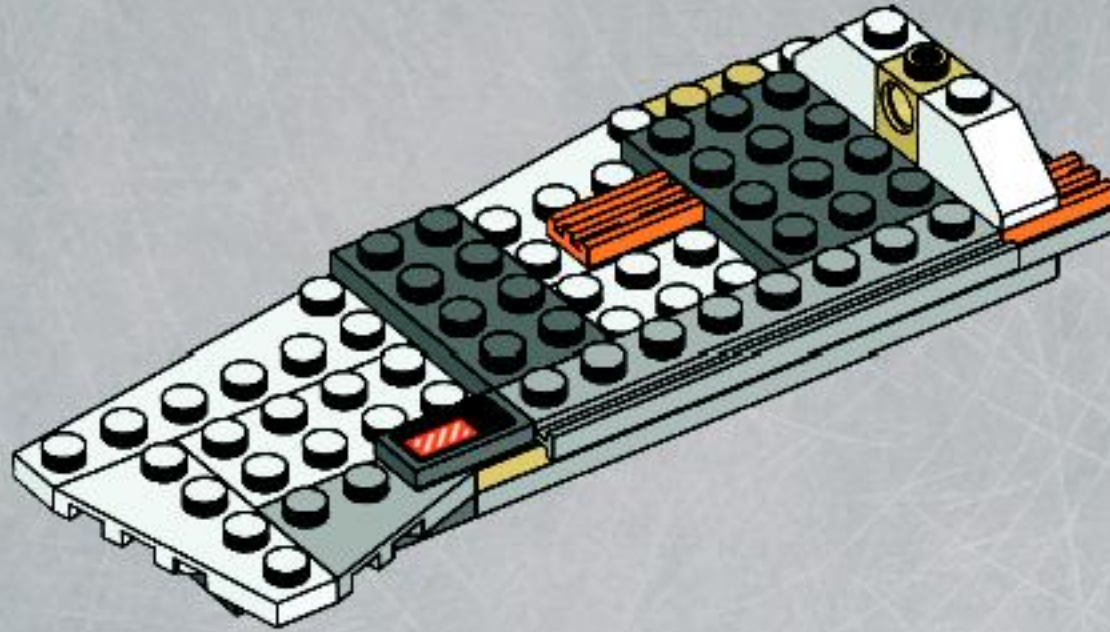

2x



2x



1x

8

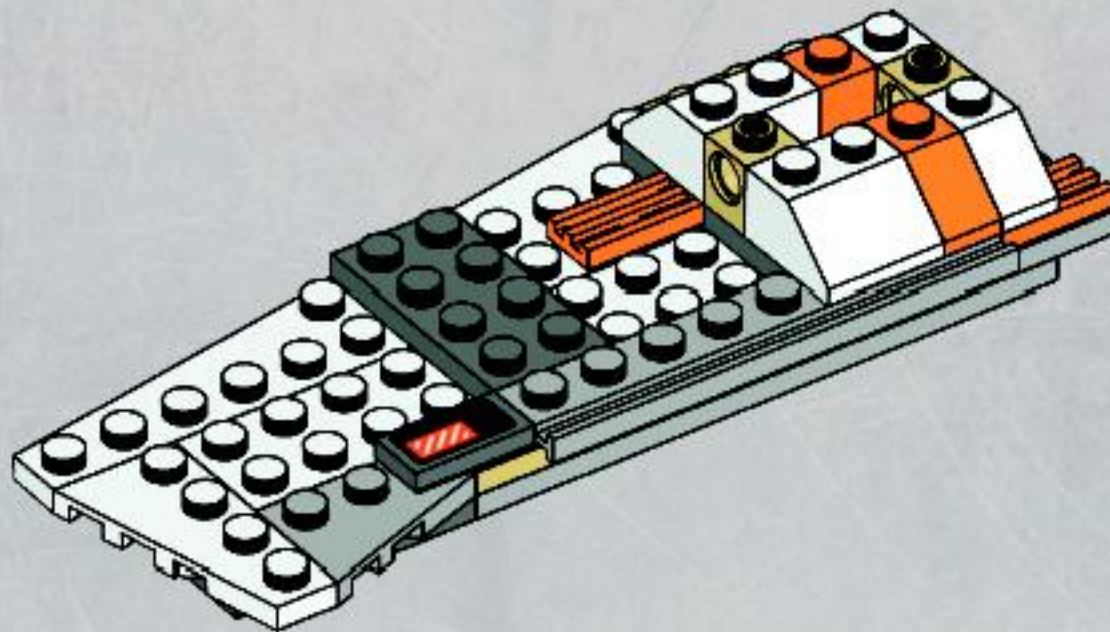

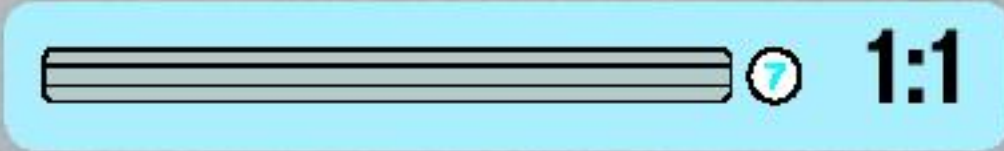
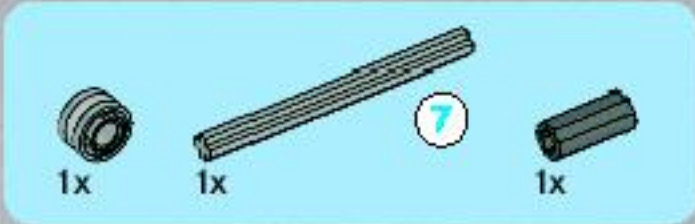

9

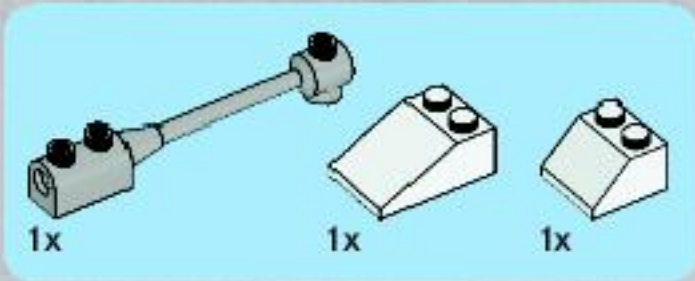
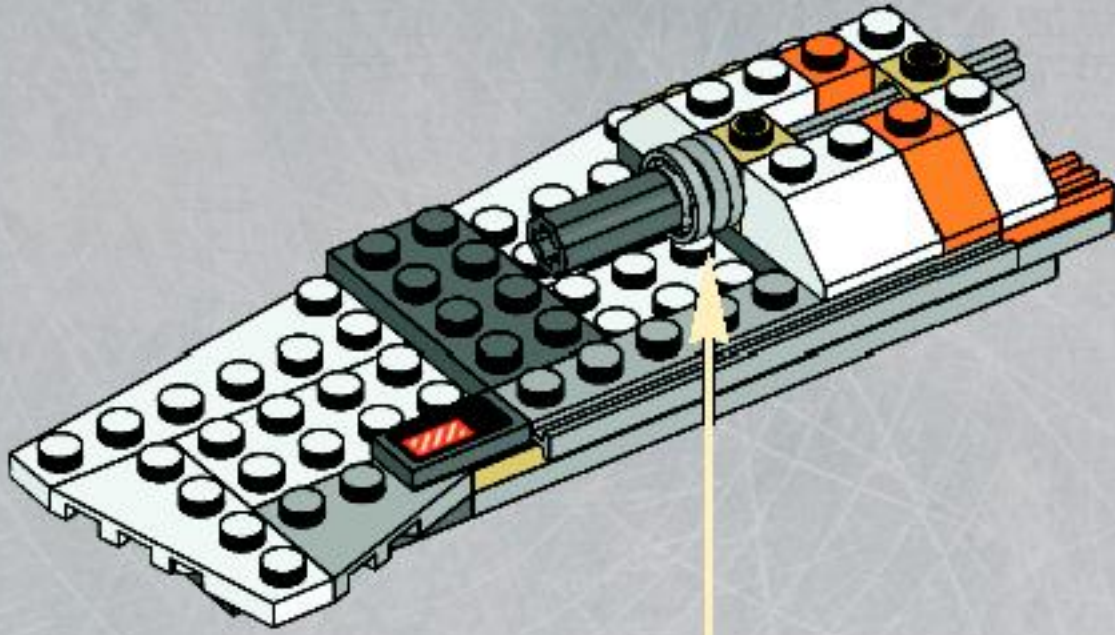
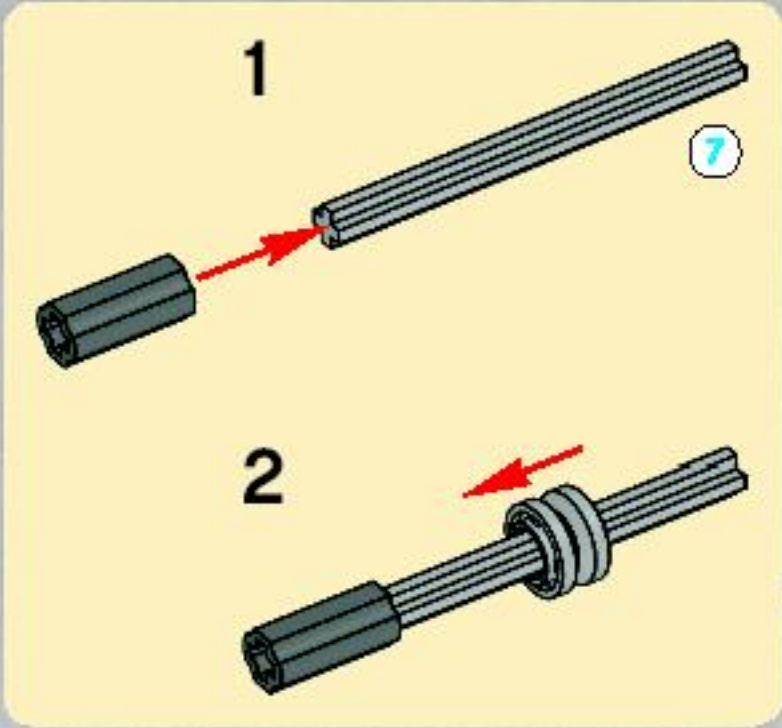

10

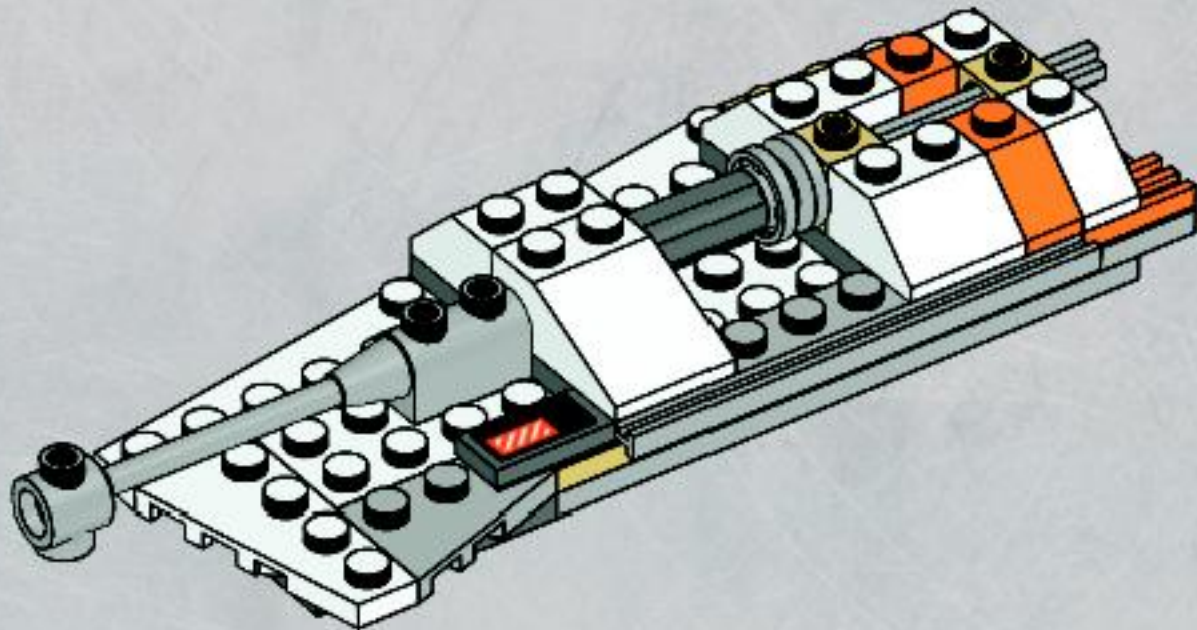

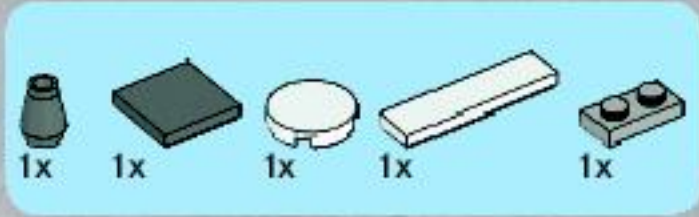

11

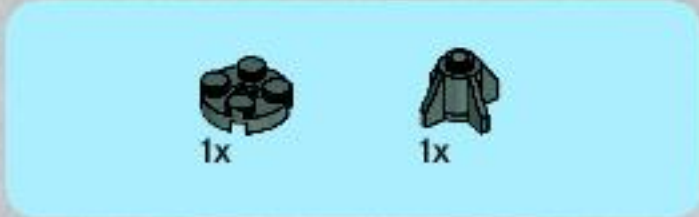
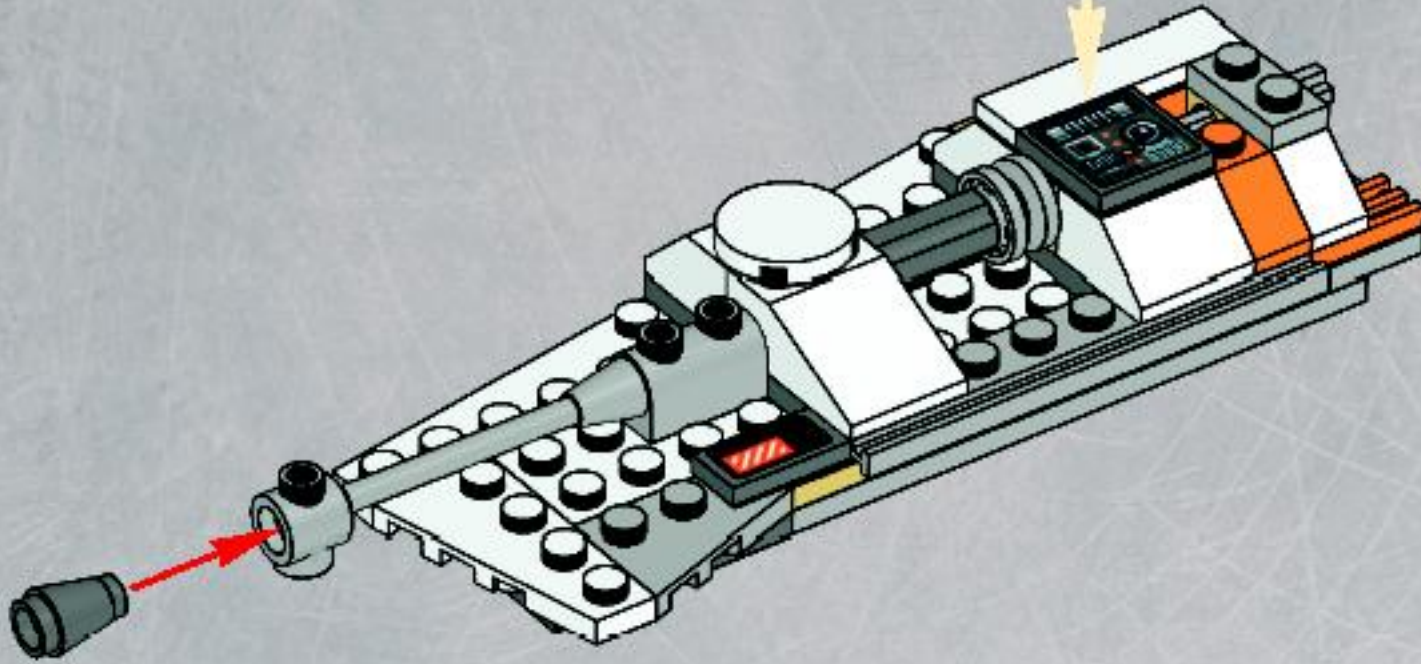

12

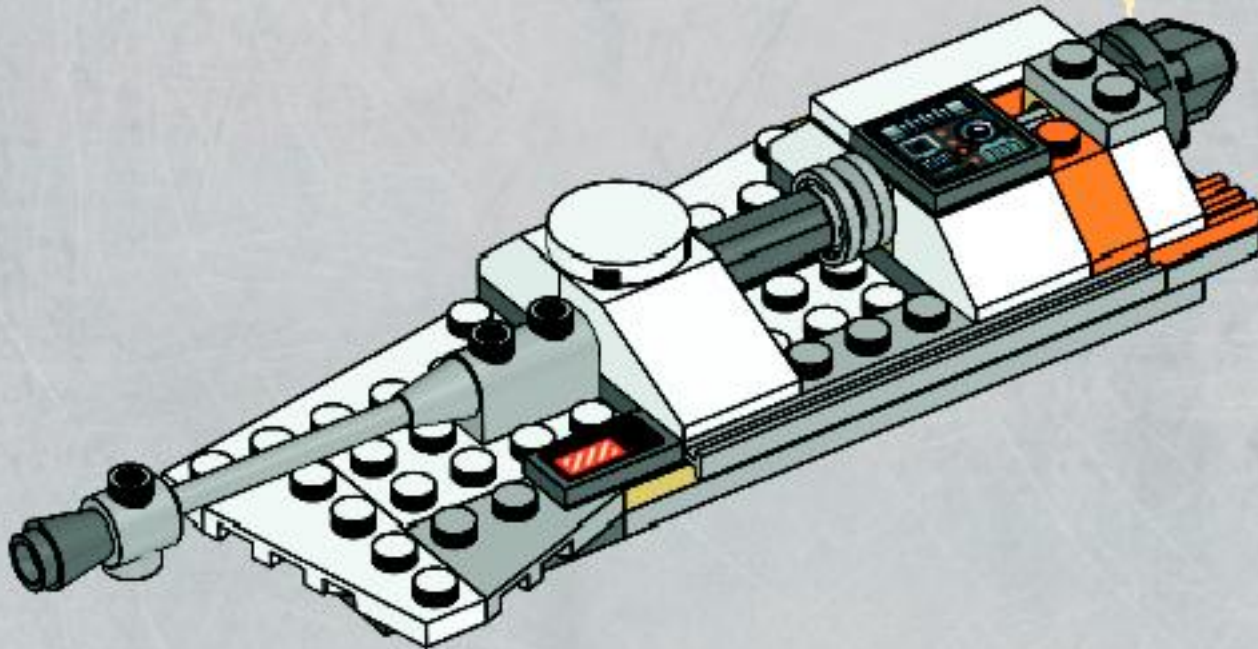



1x



1x

13

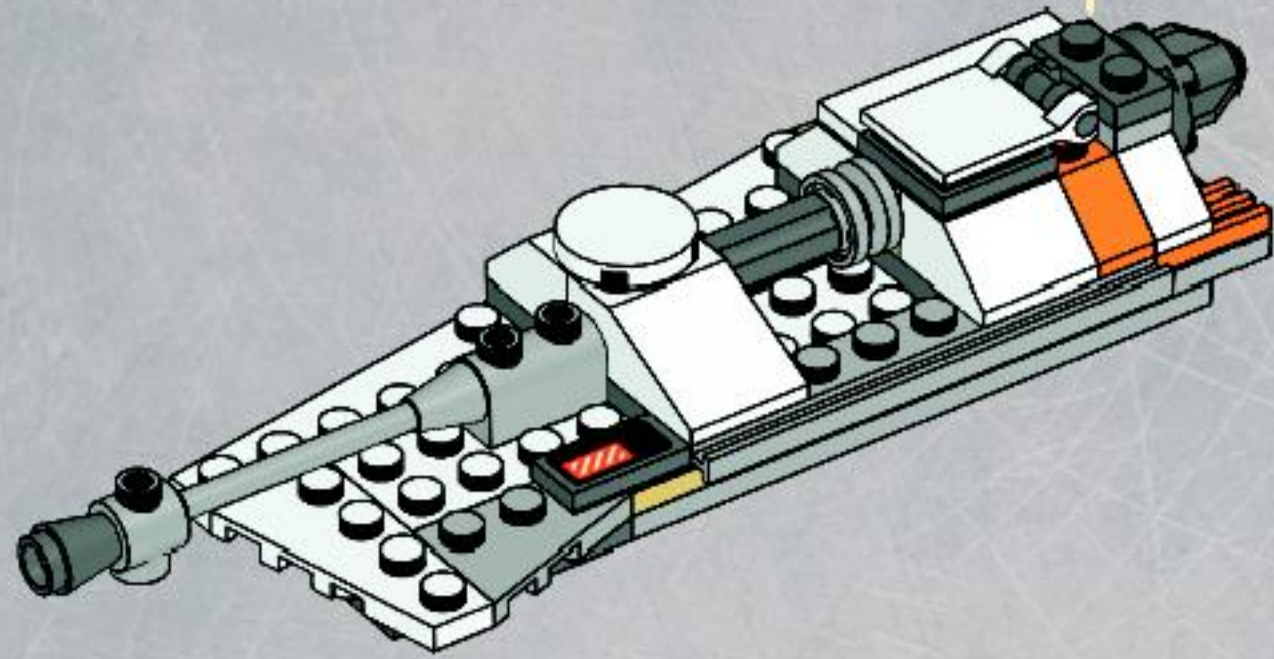
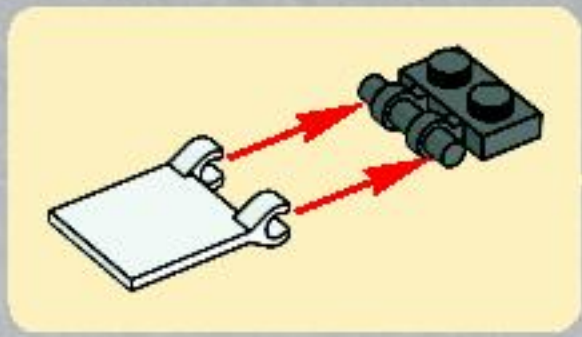

21

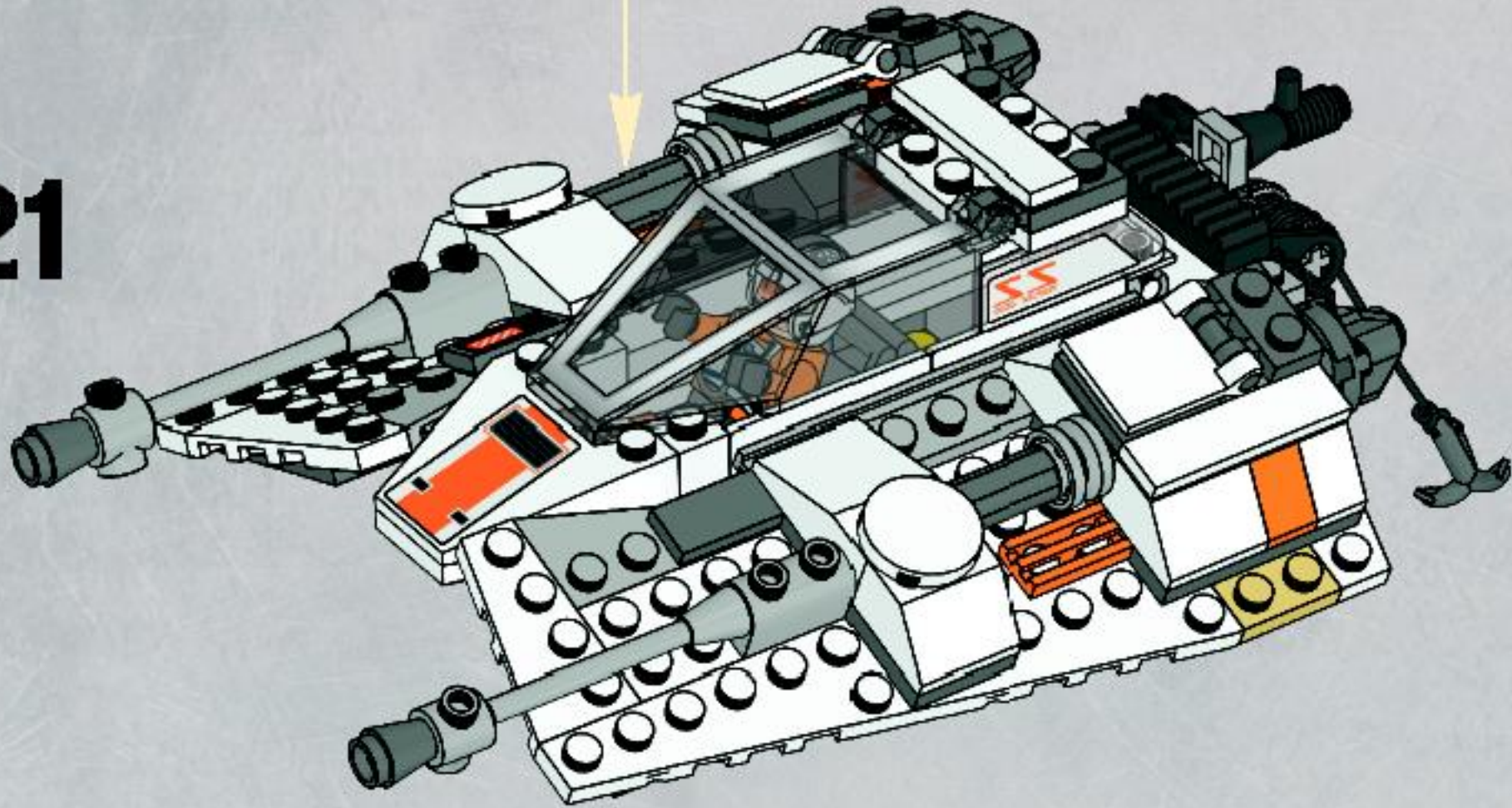

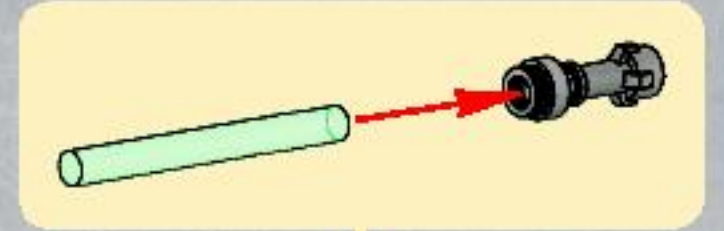
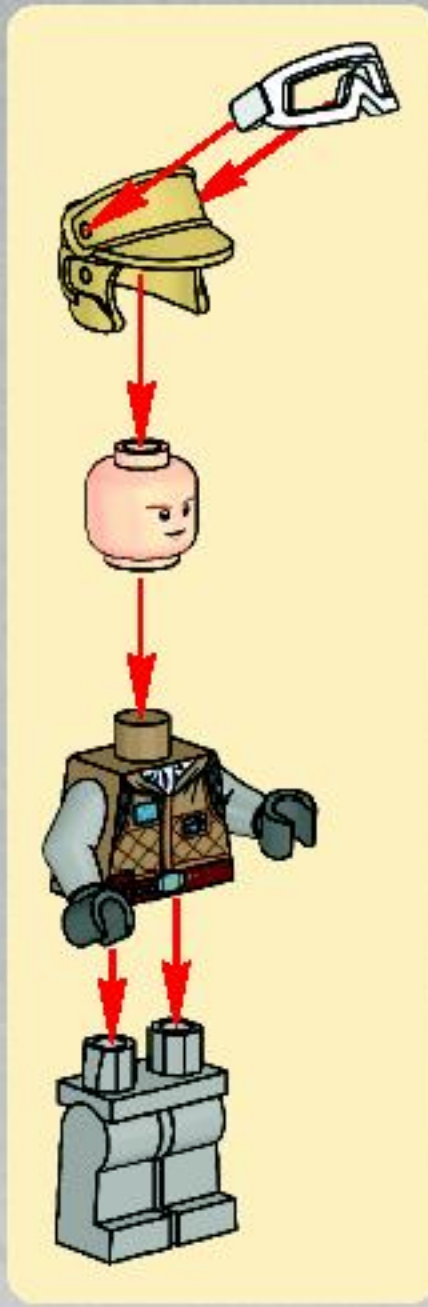
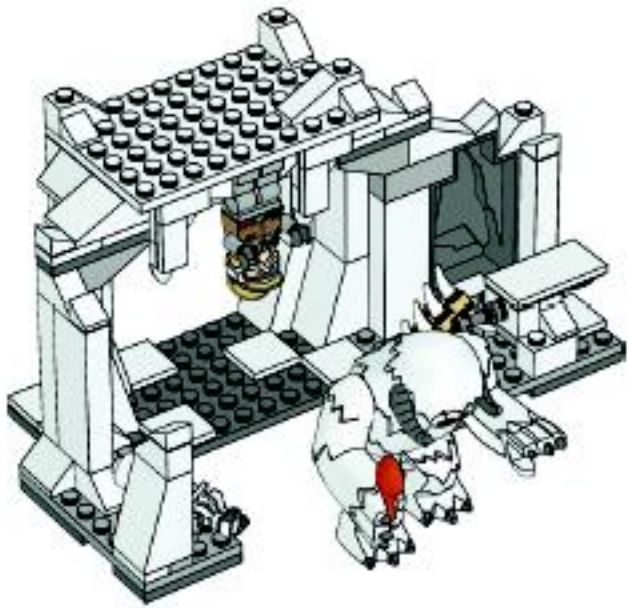

1

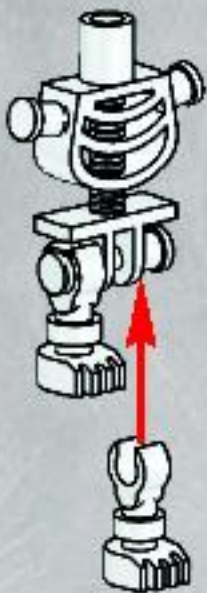

2

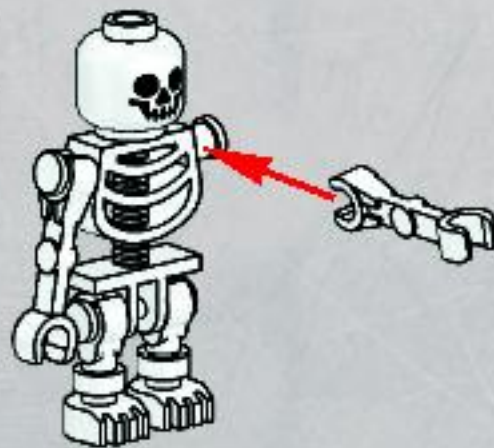

3



1

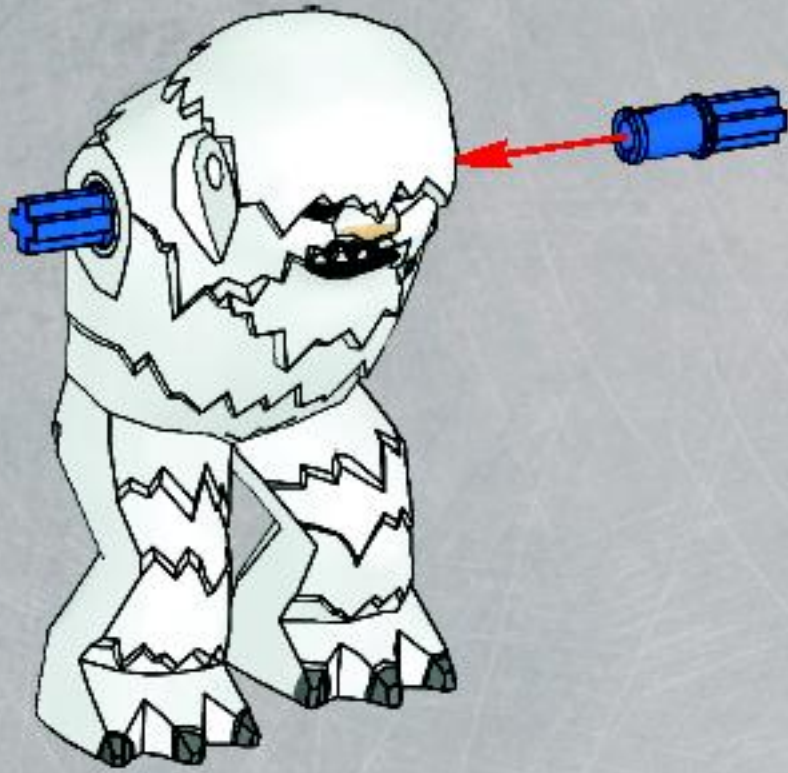

3



2

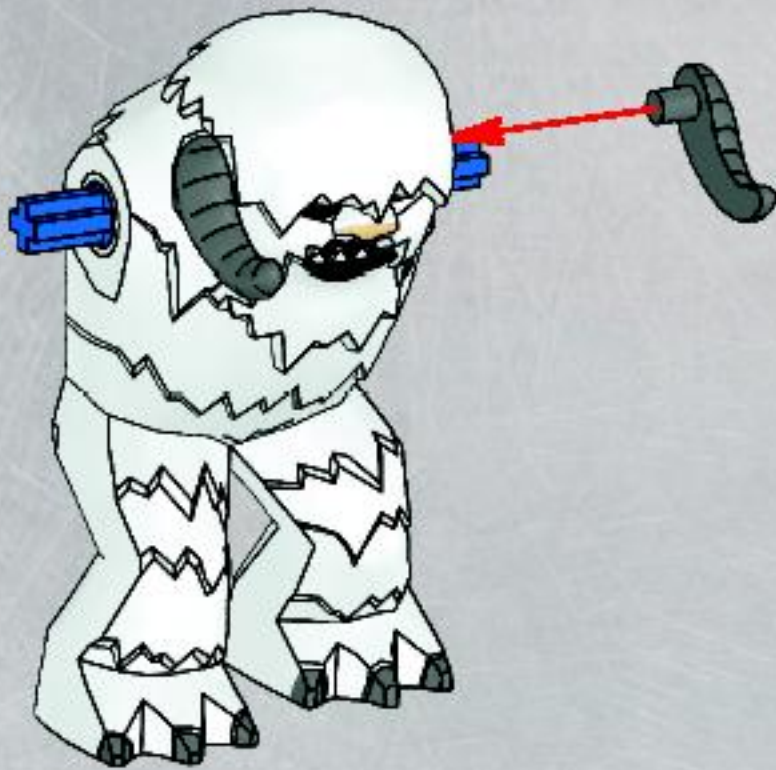

4



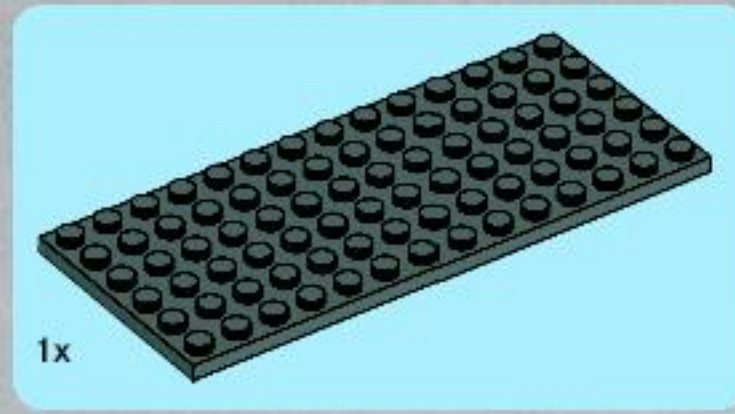
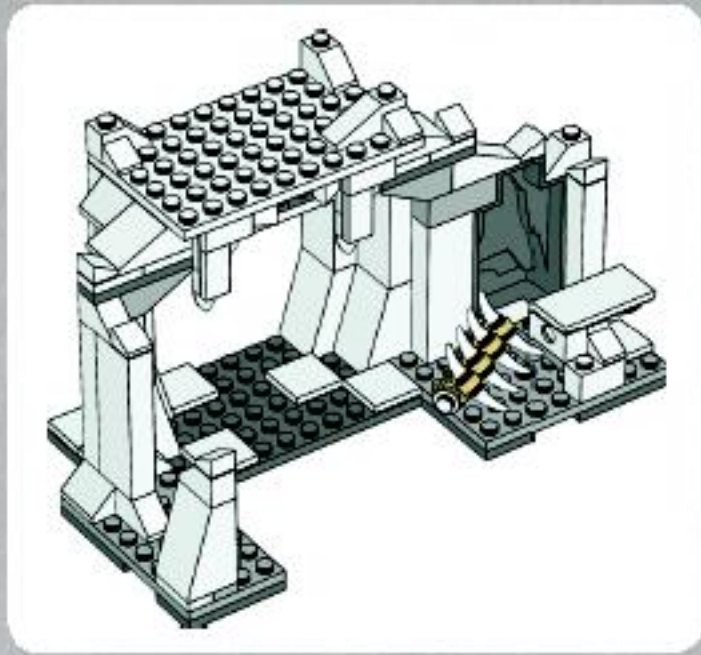

1

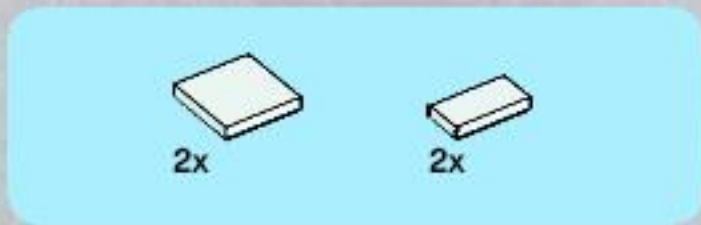
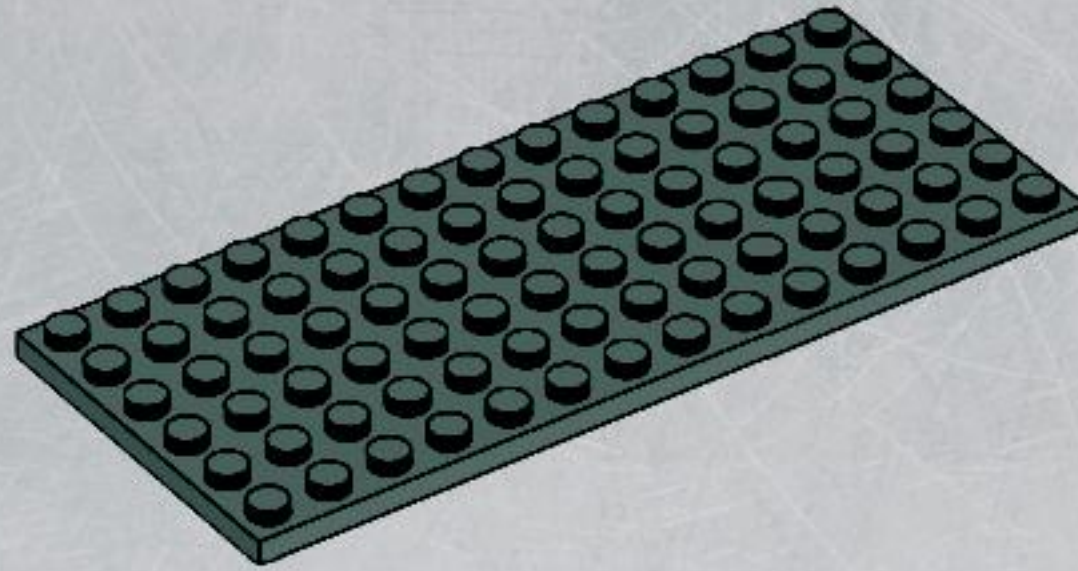

2

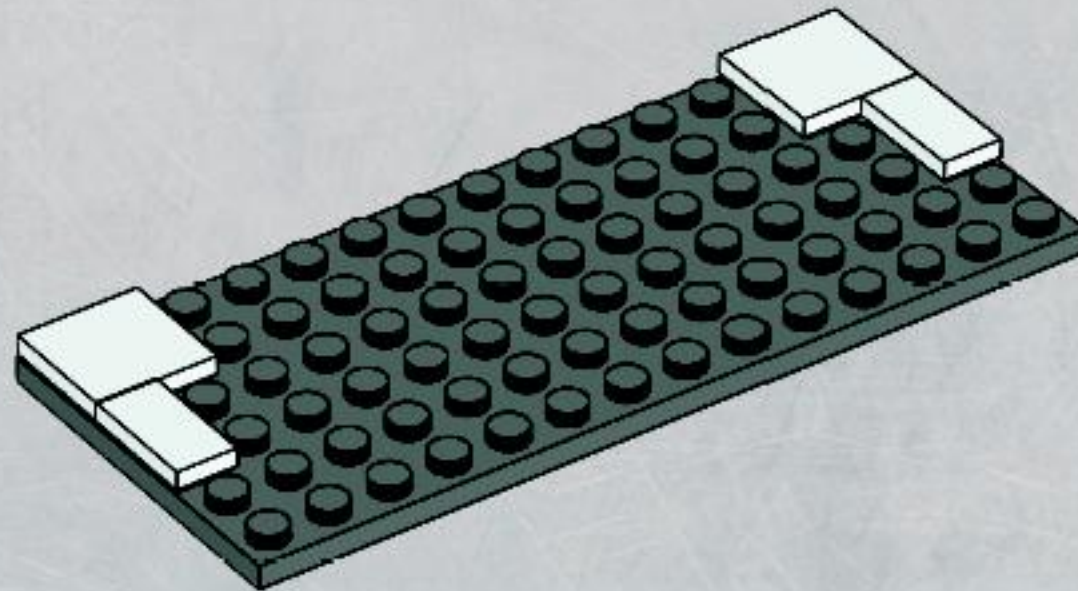

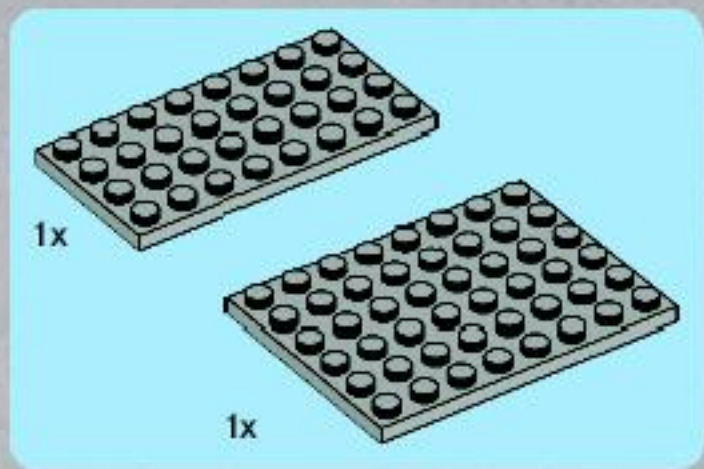

3

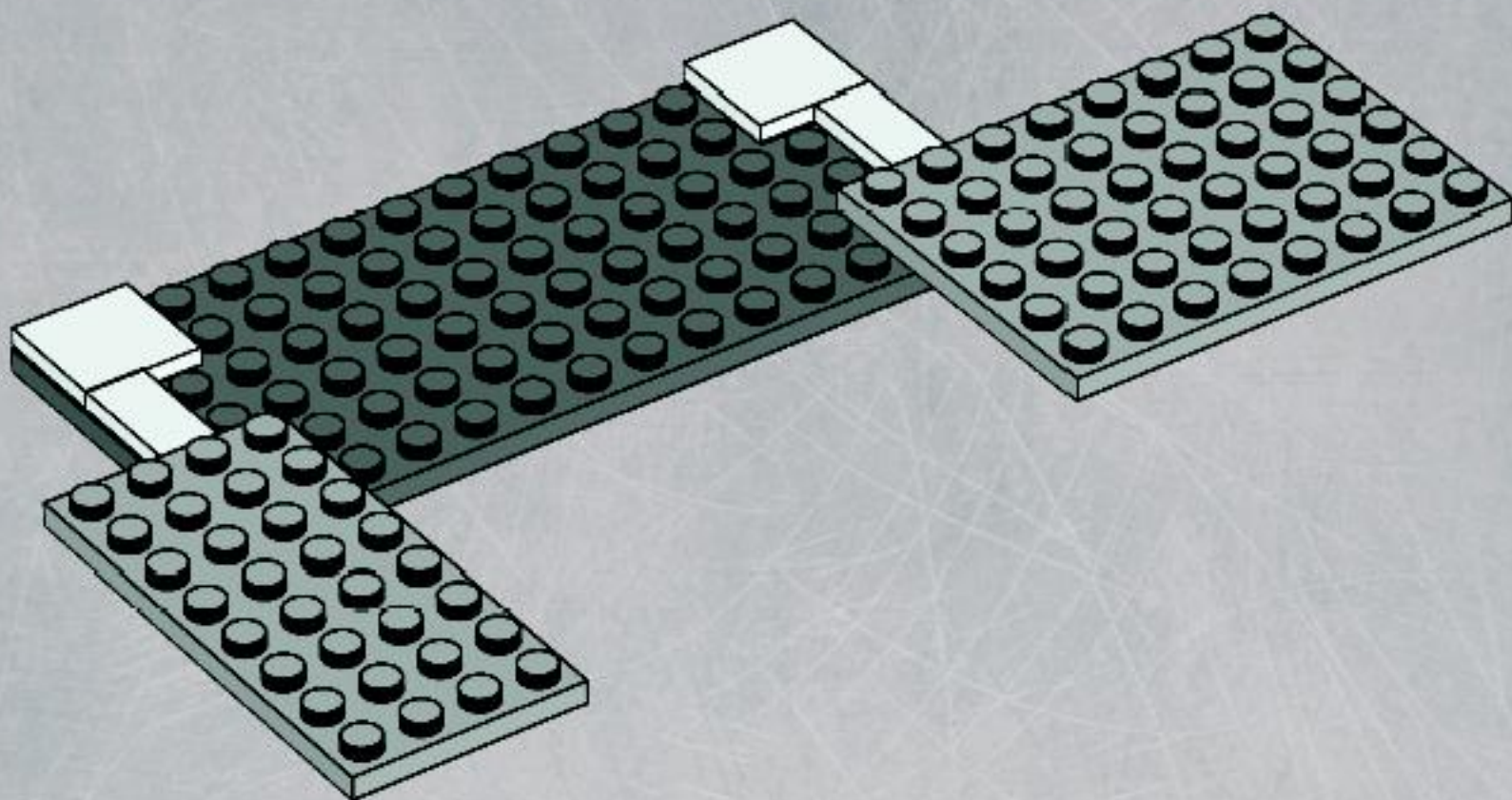

4

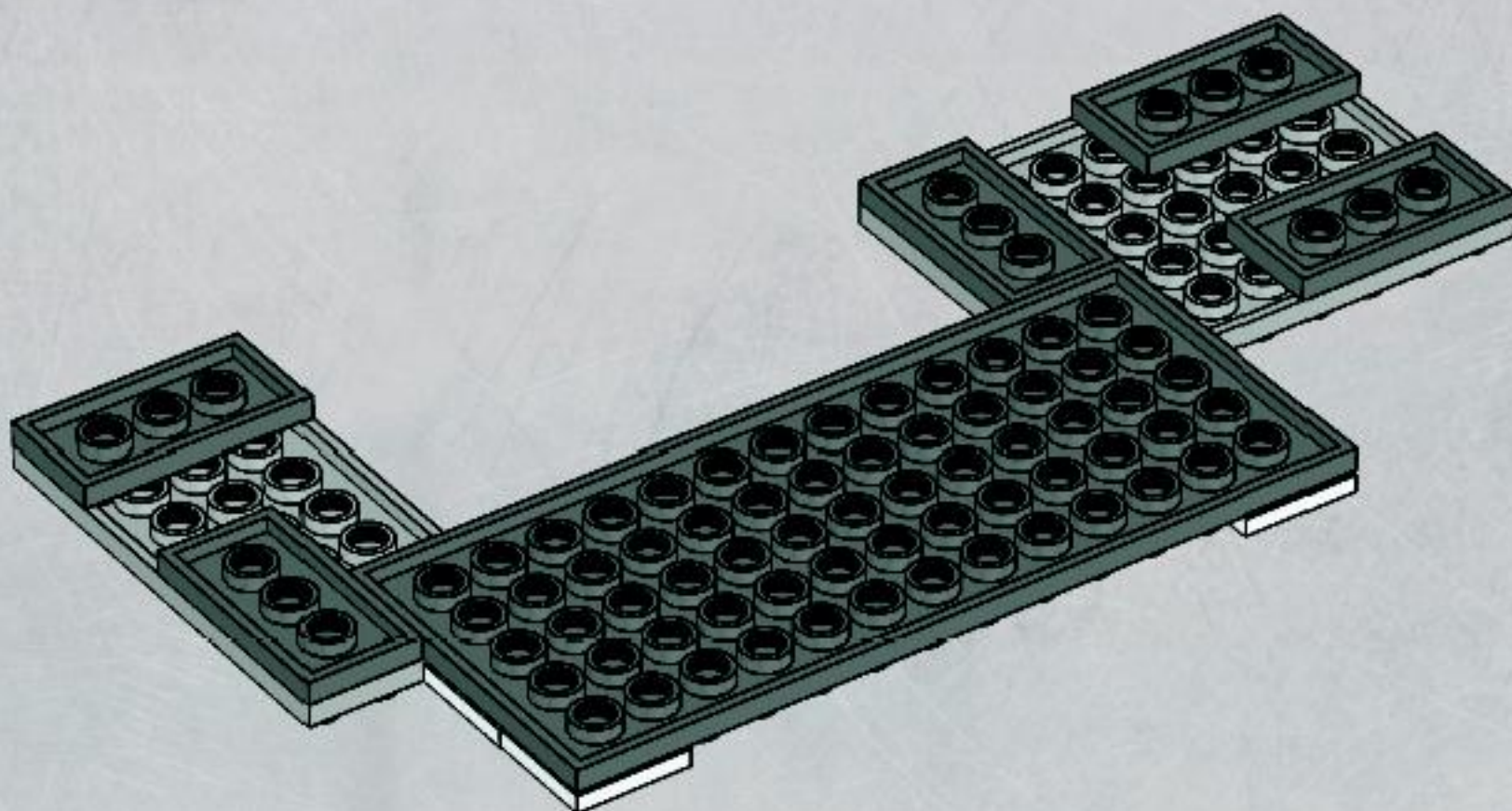



4x

5

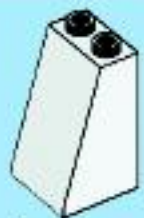
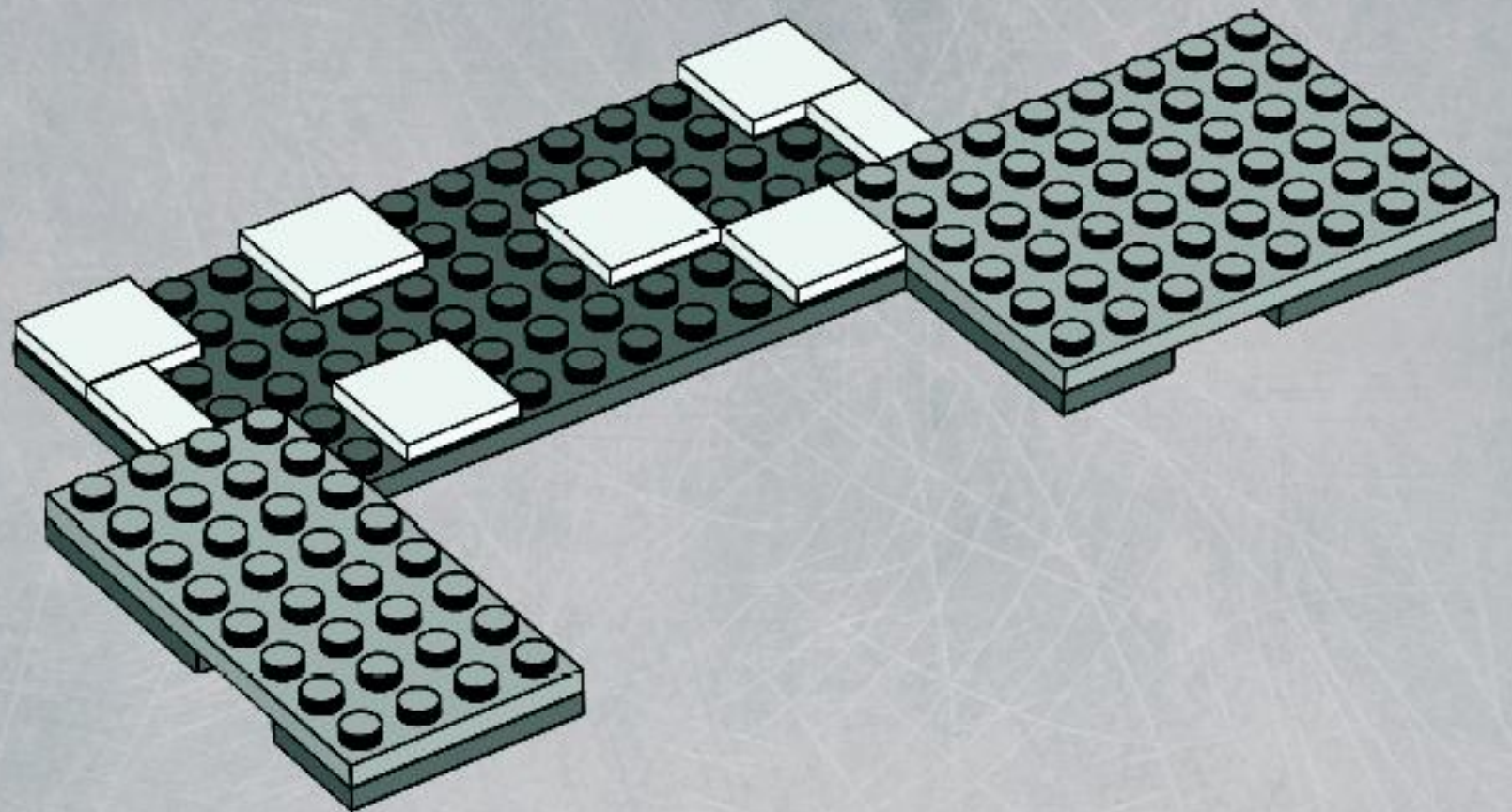

4x

6

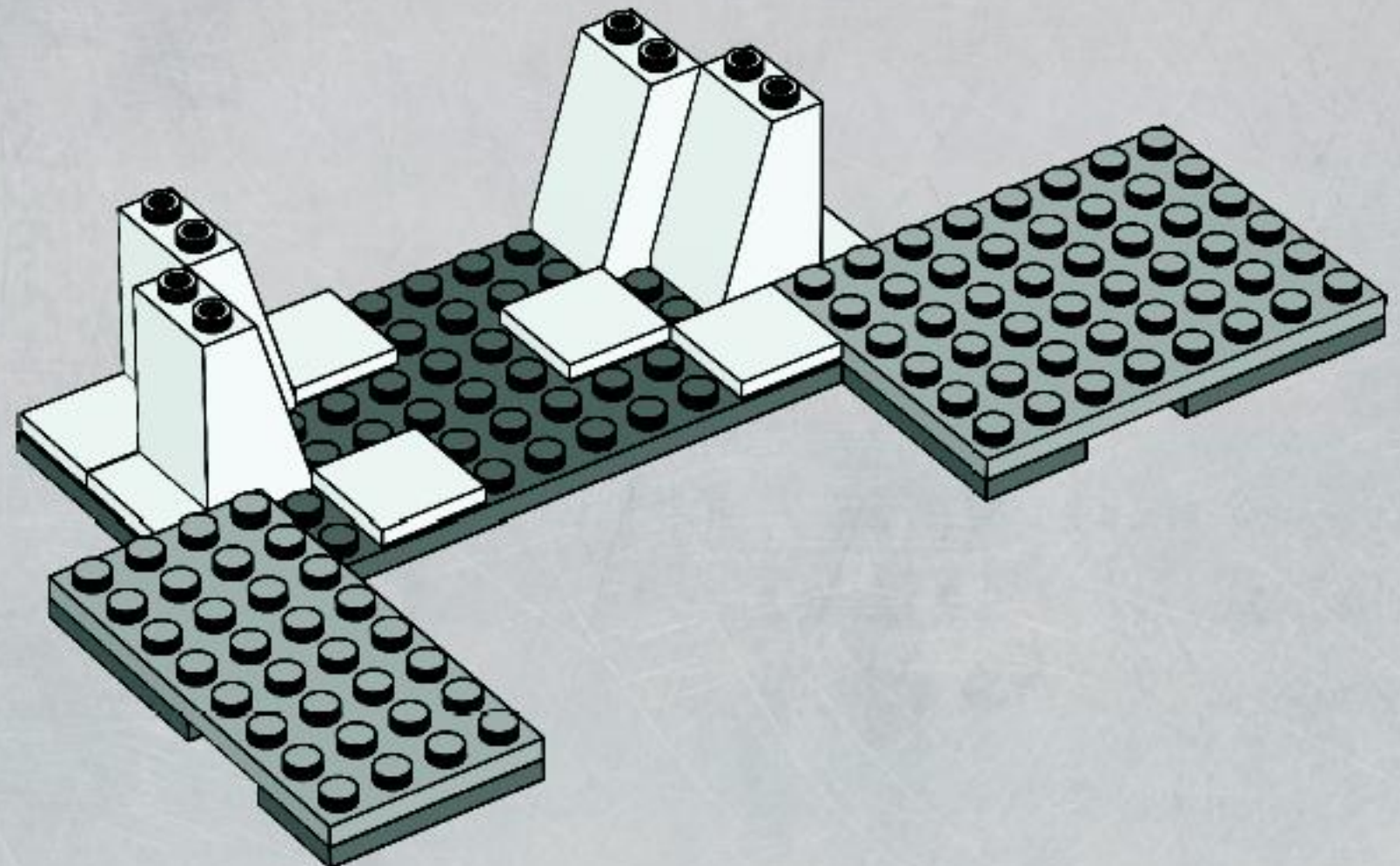



2x



1x

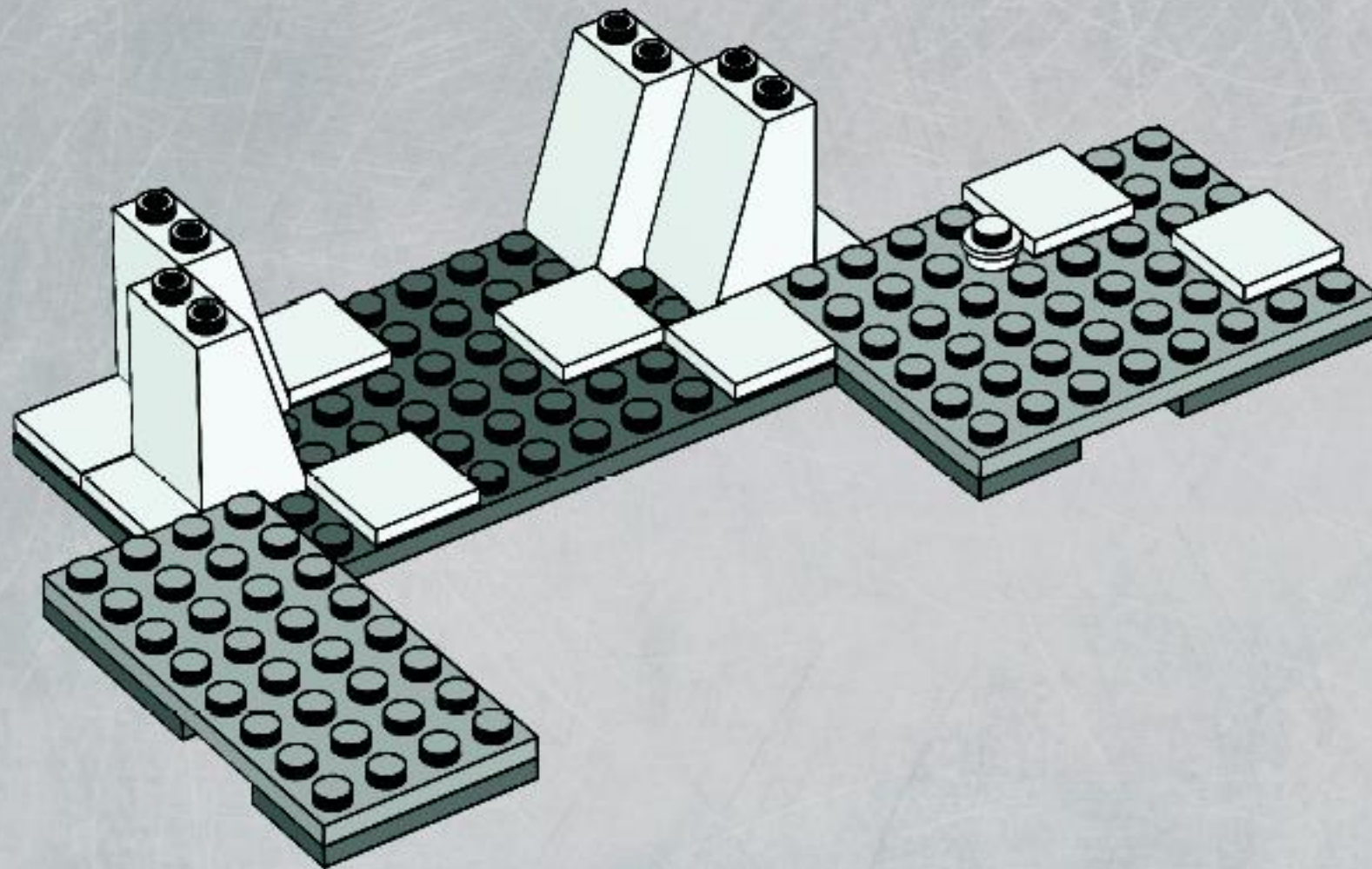

7

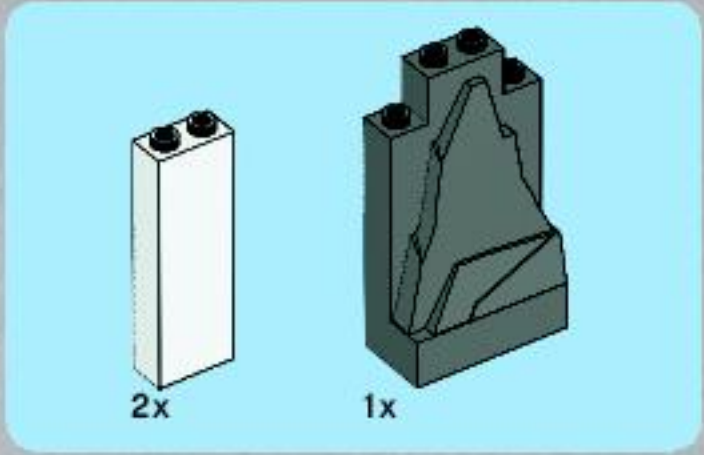

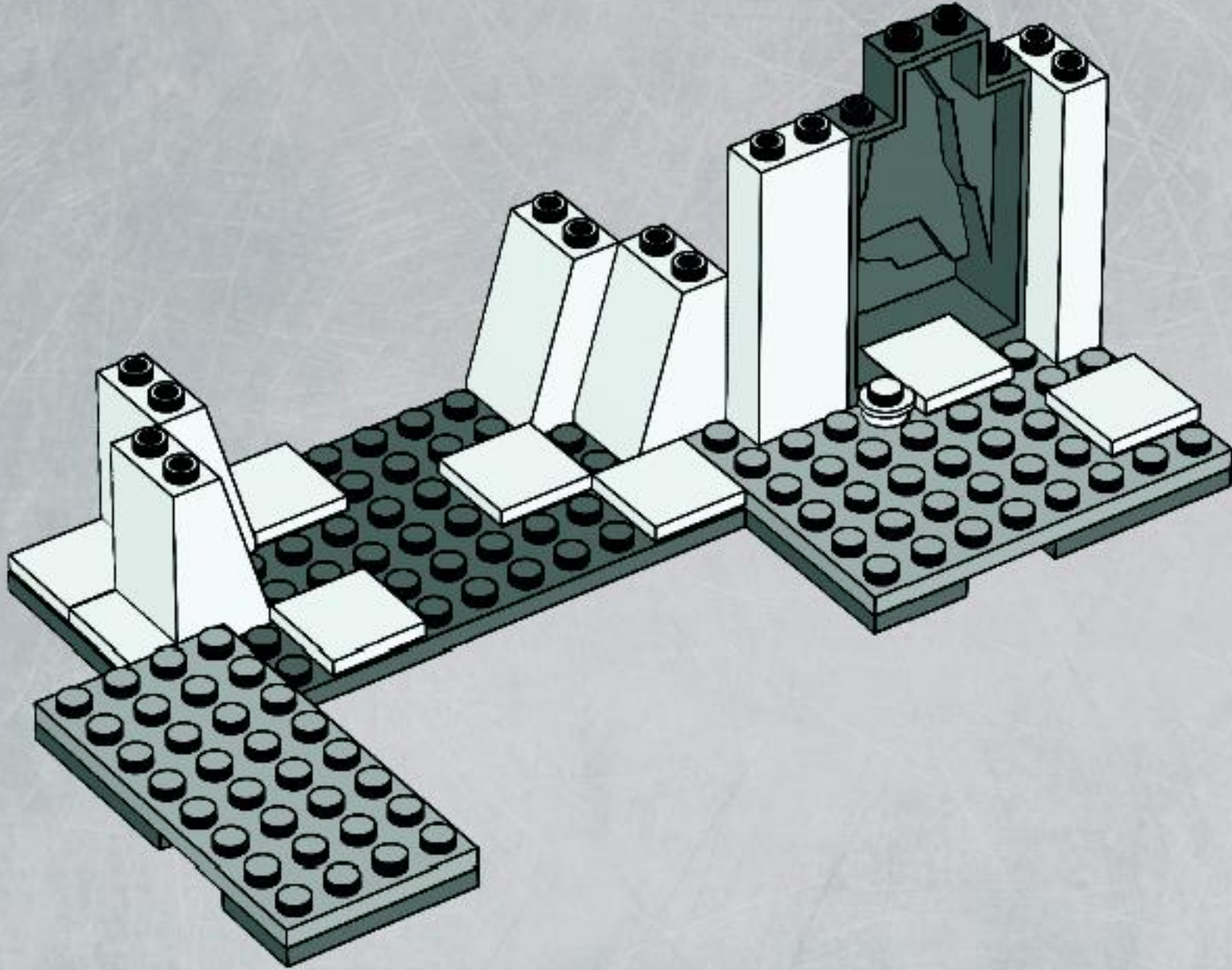

8

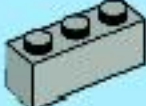

 1x
  1x
  1x

9

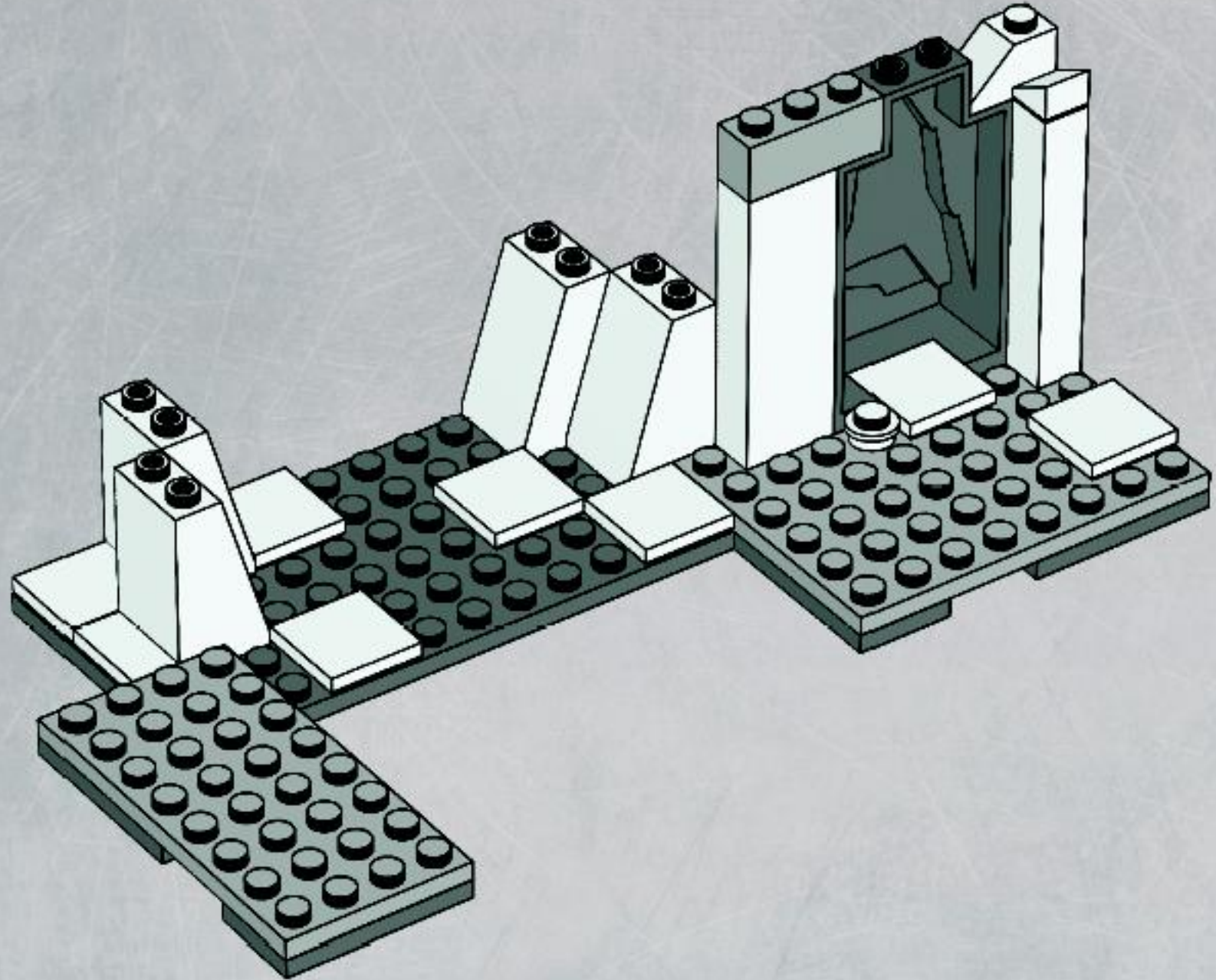

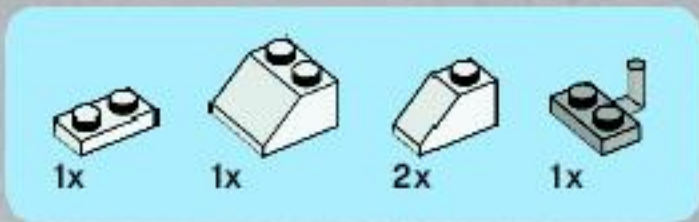

10

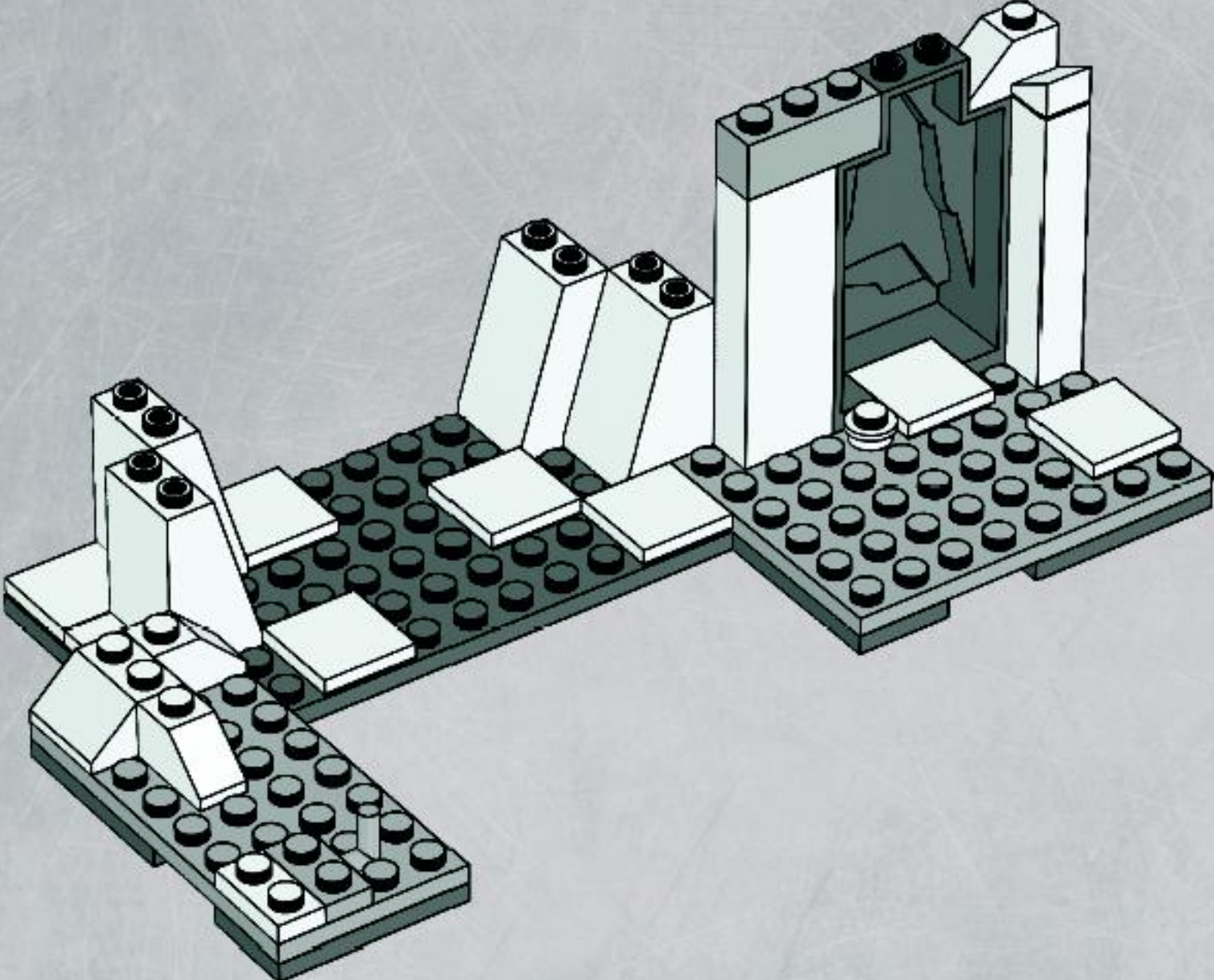

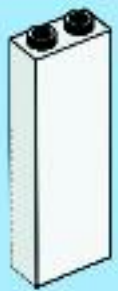

4x

11

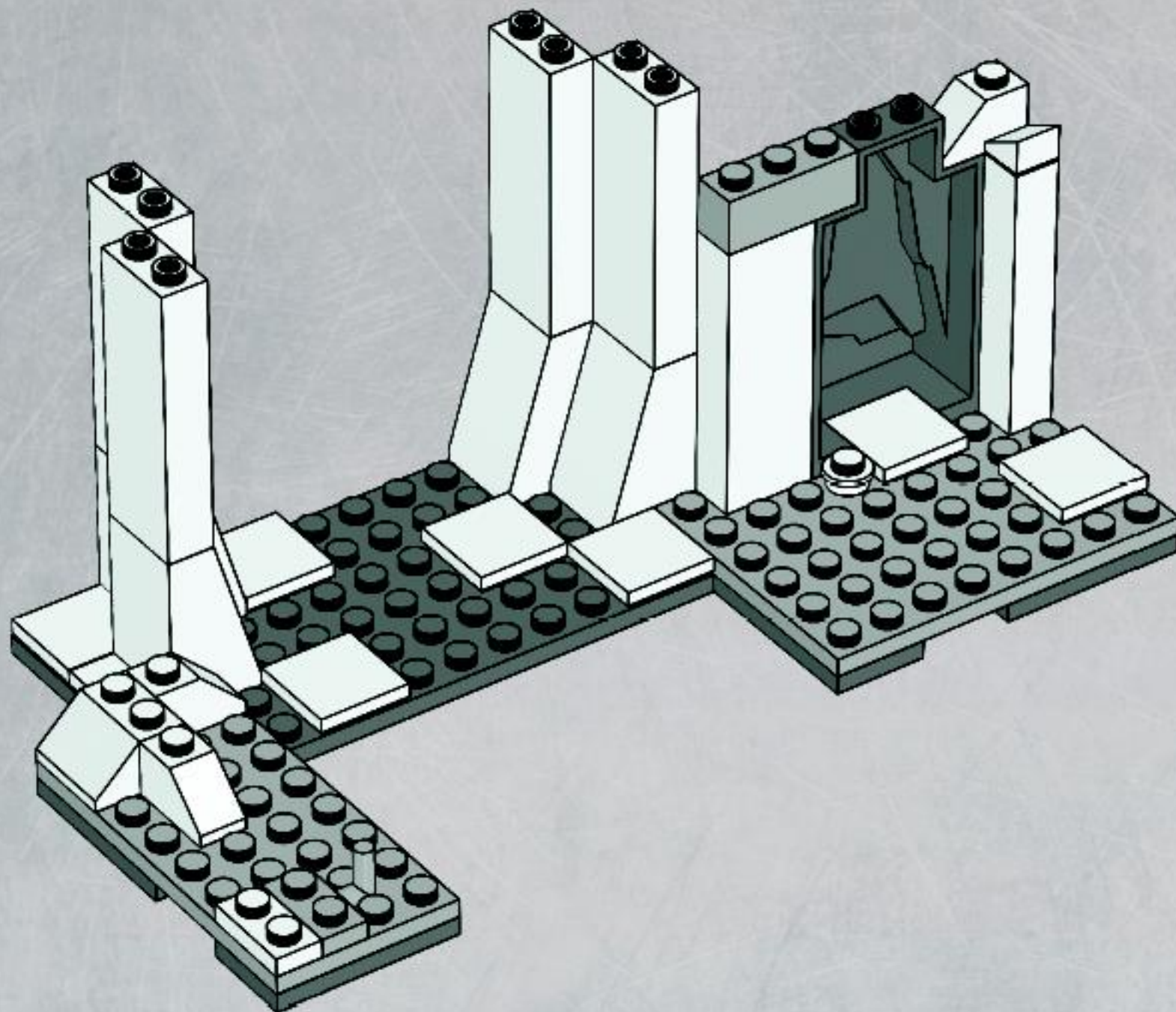

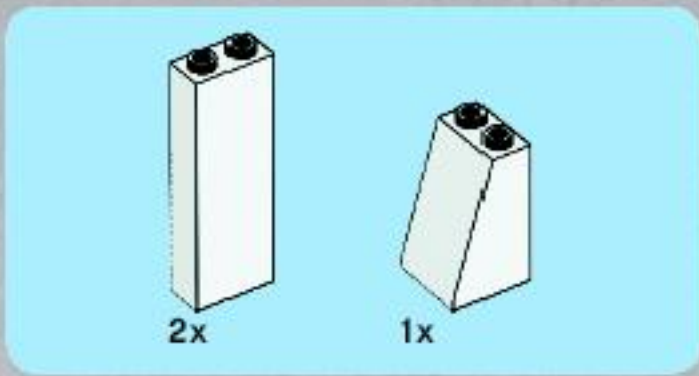

12

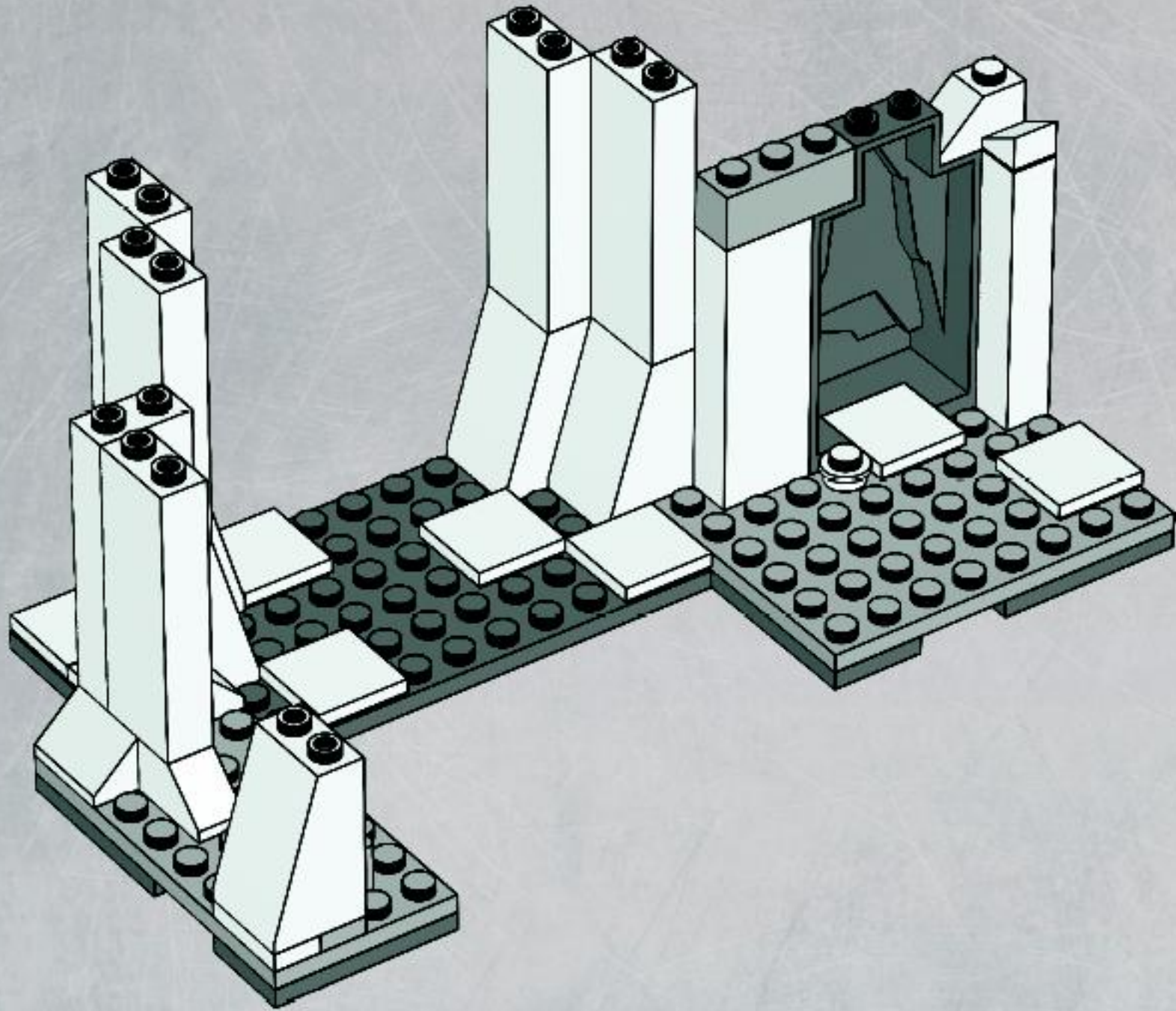

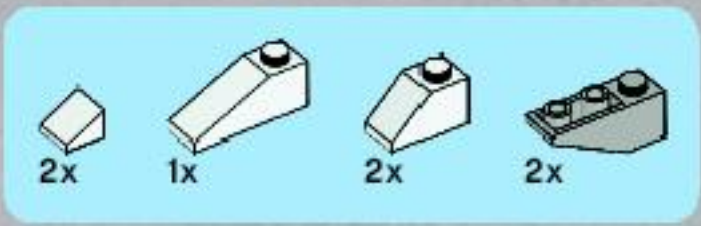

13

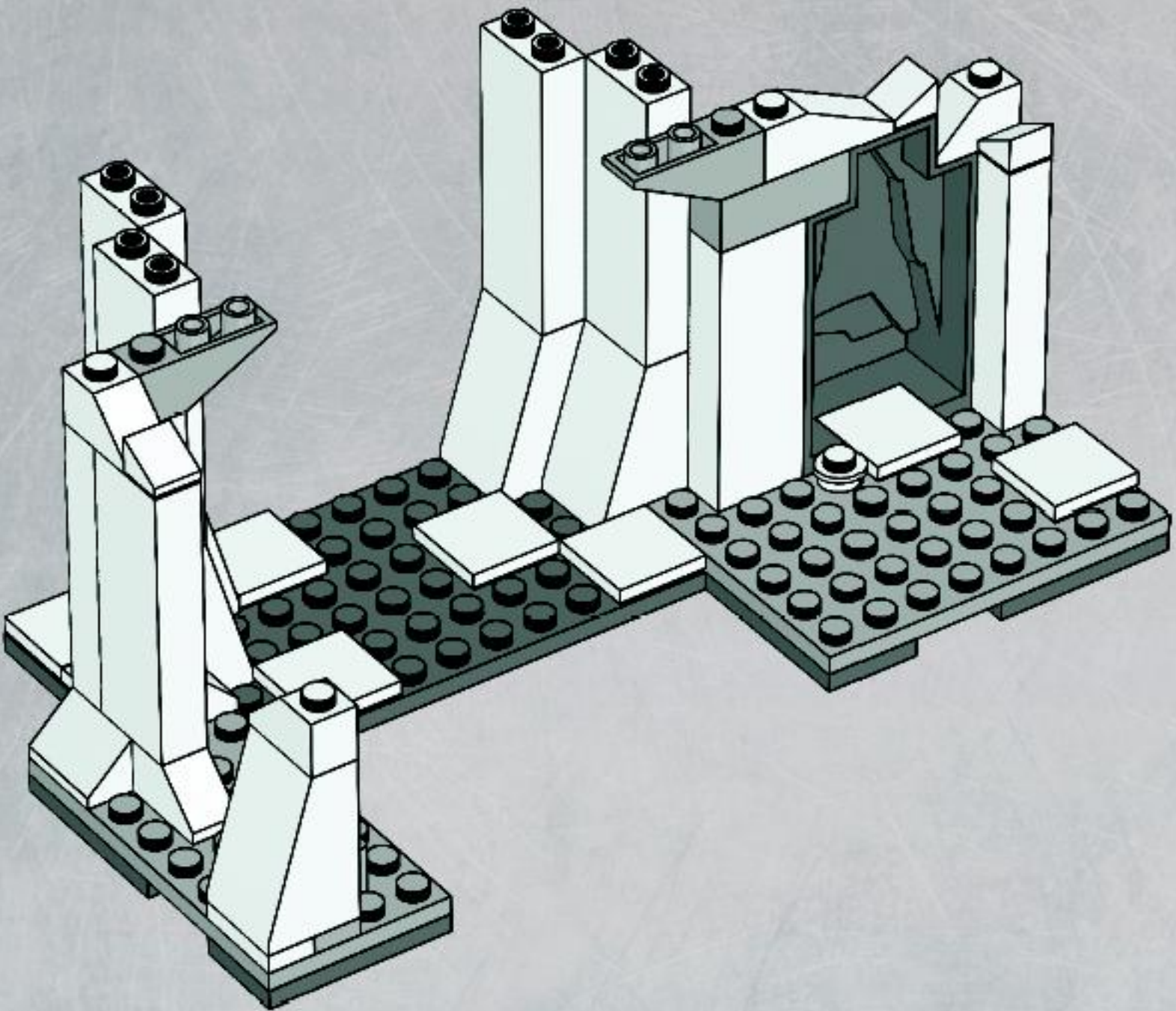



2x



1x

14

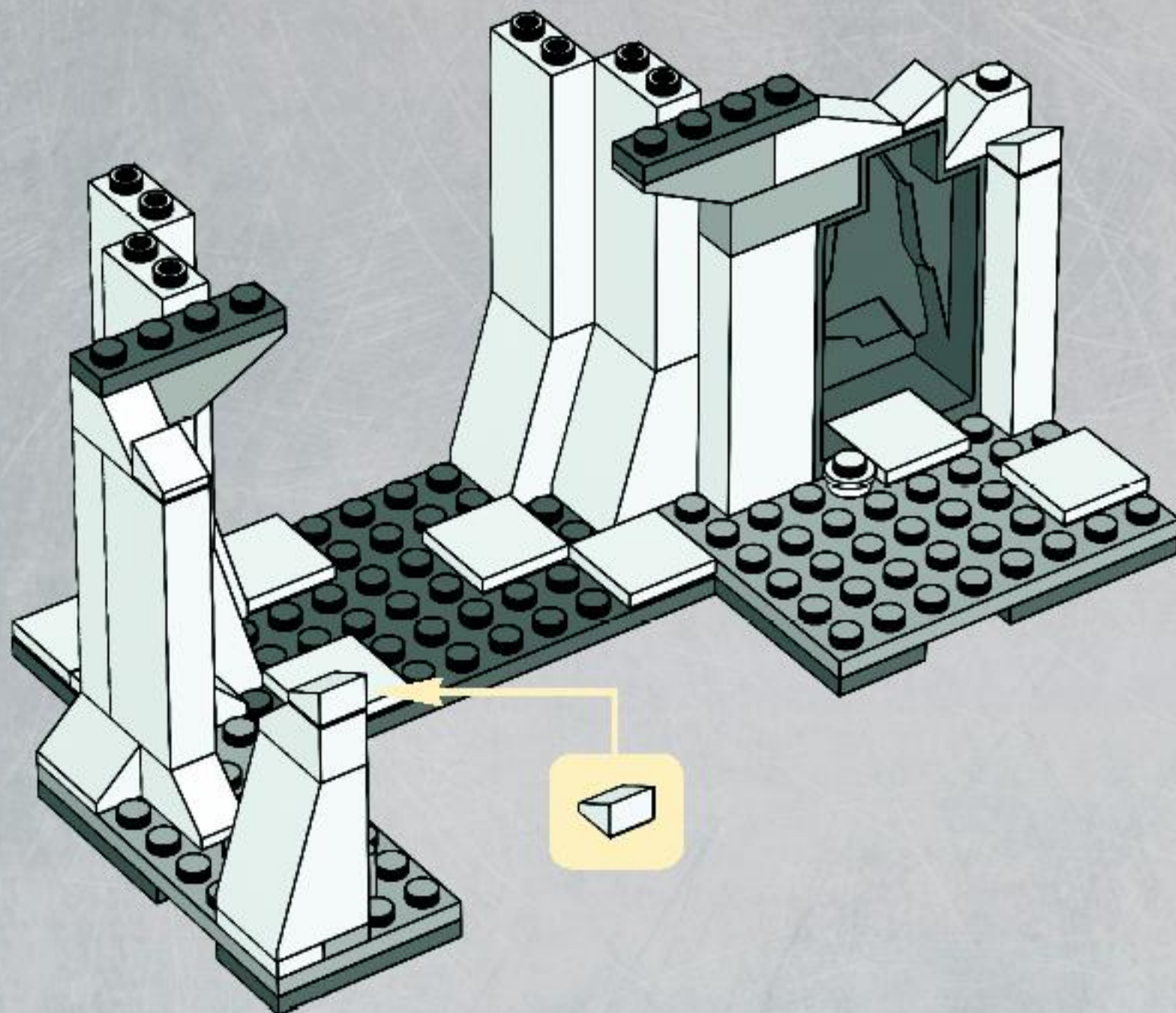



2x



2x

15

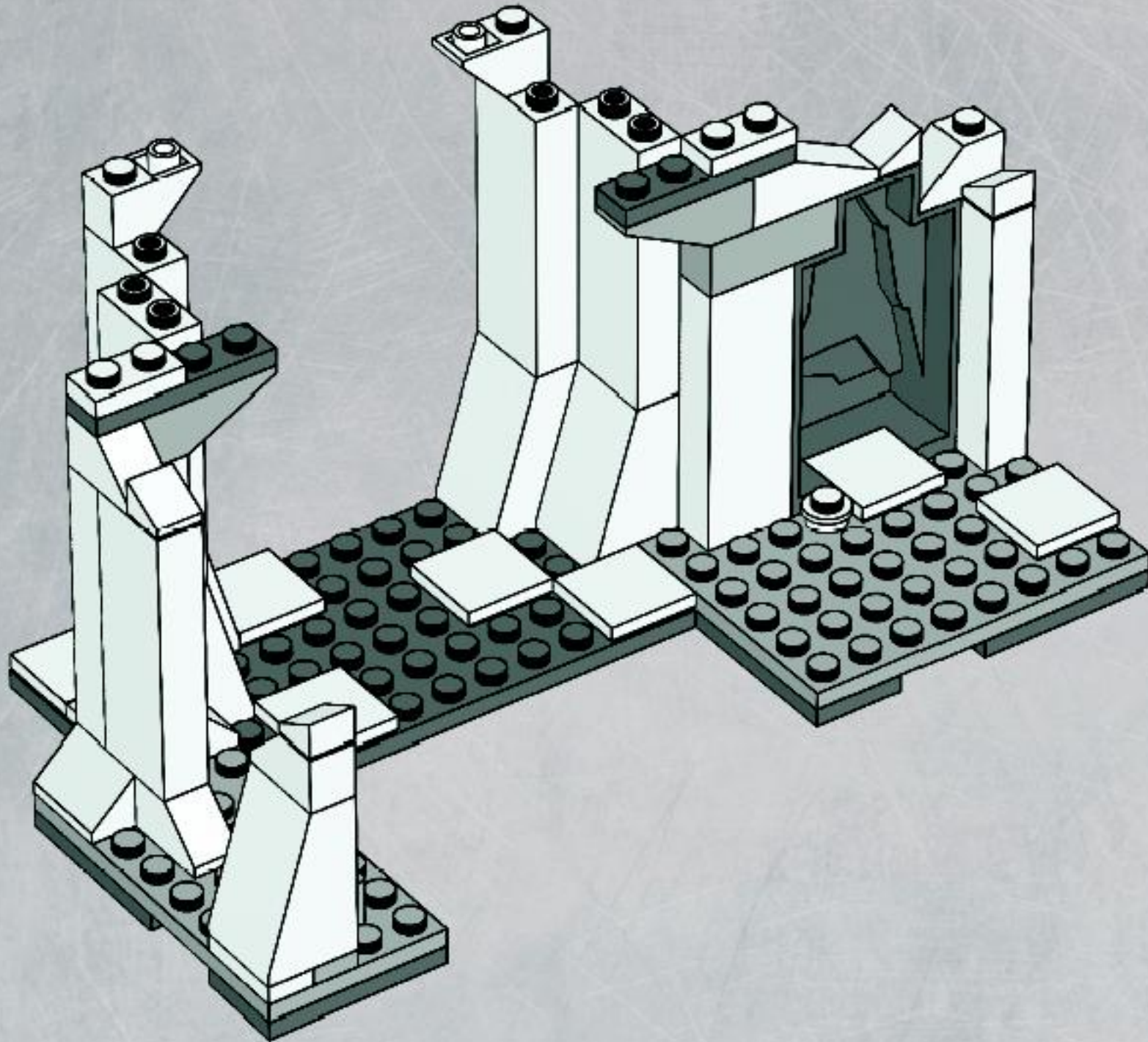

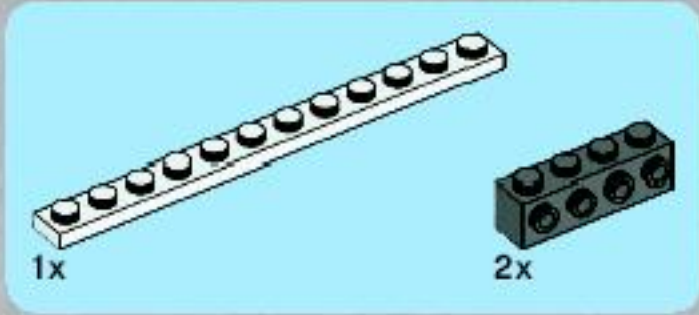

16

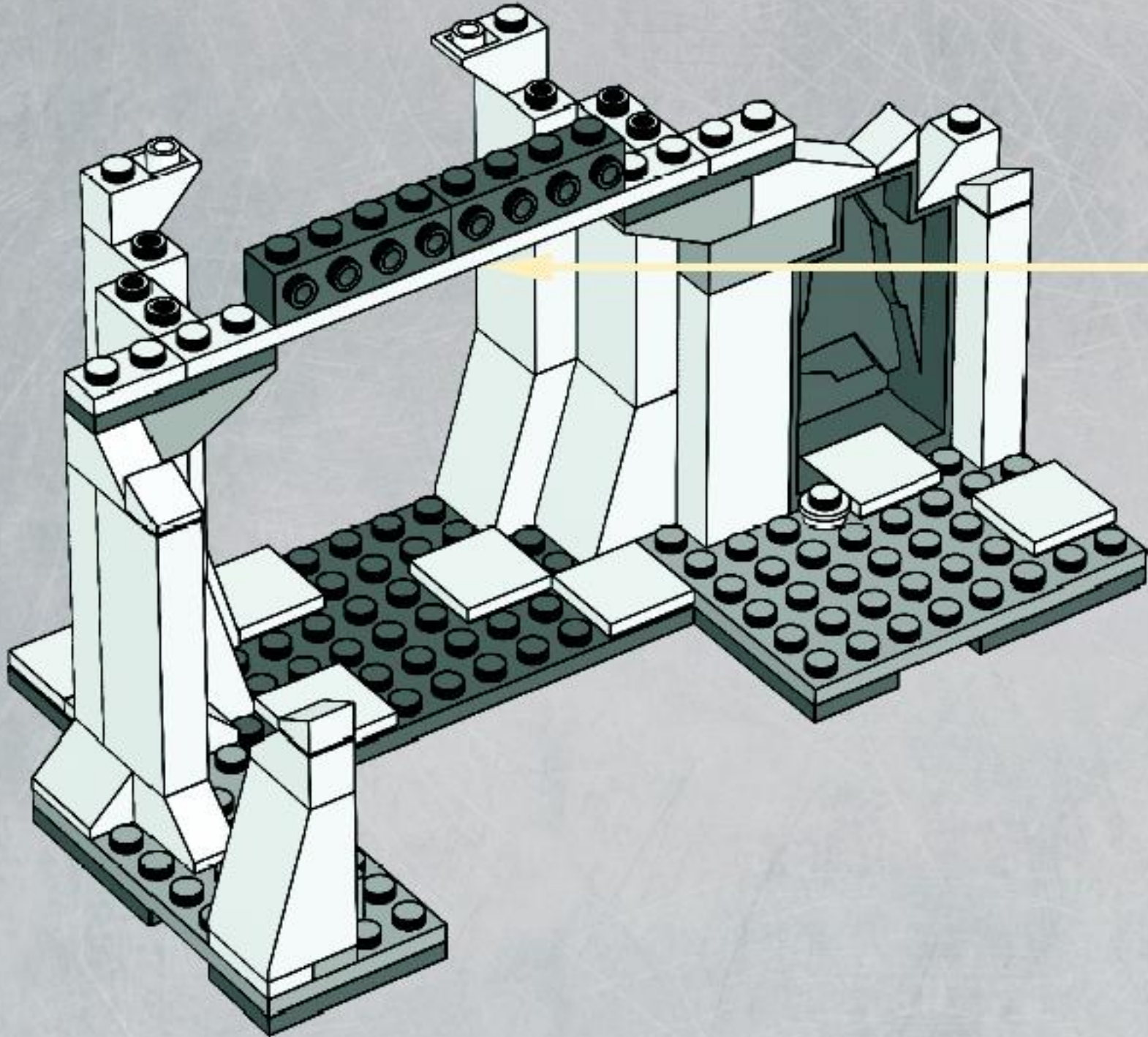
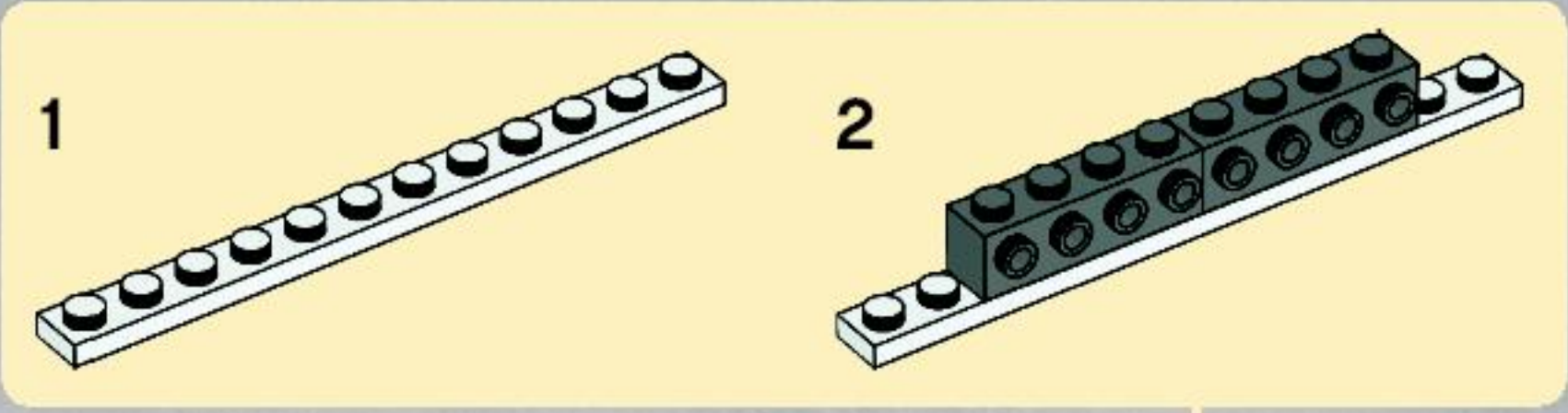



2x



2x

17

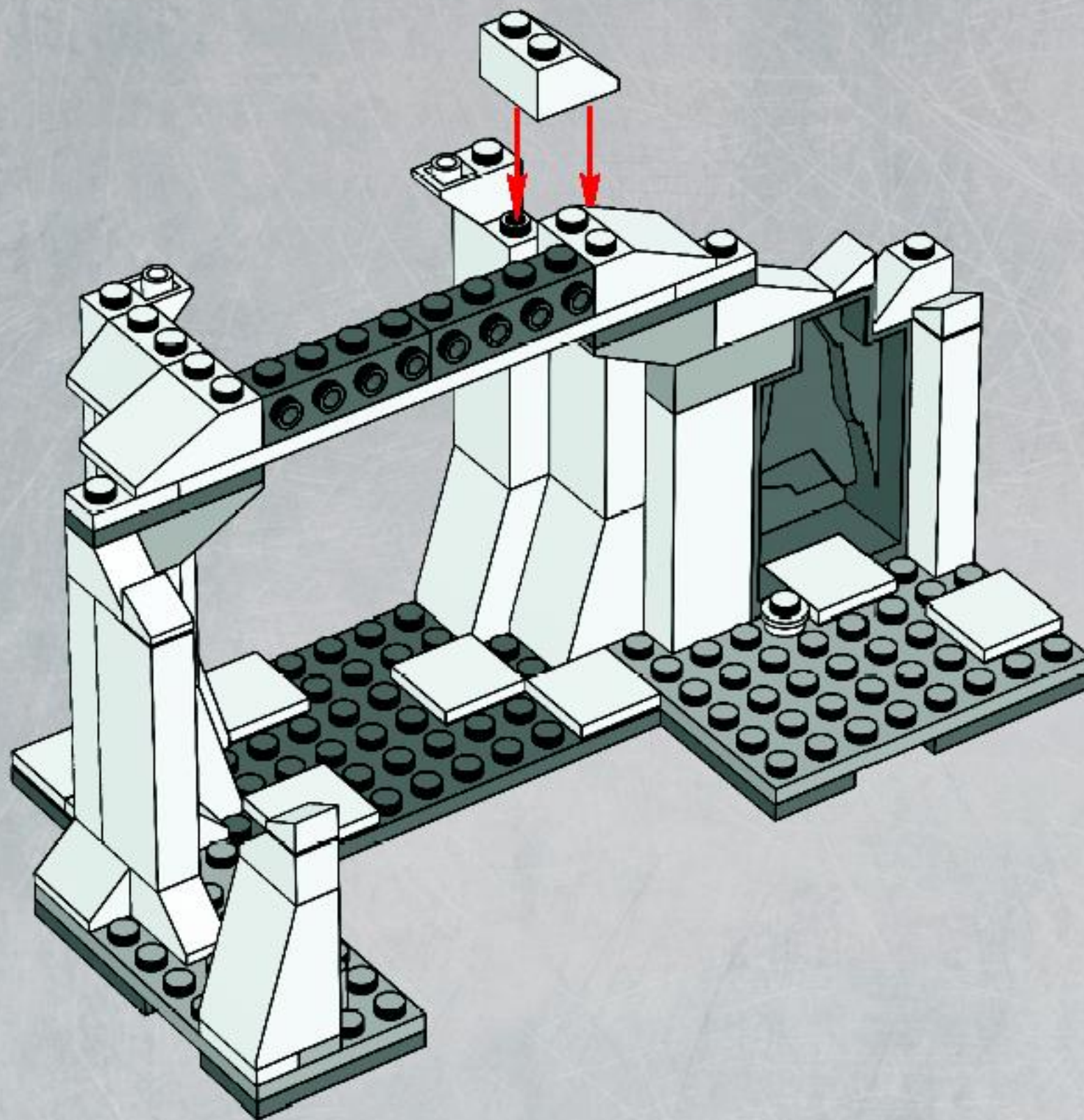



2x



4x



4x

18

1

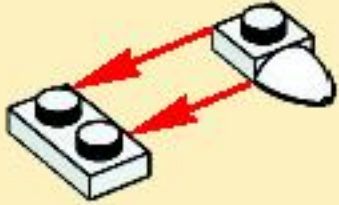

2

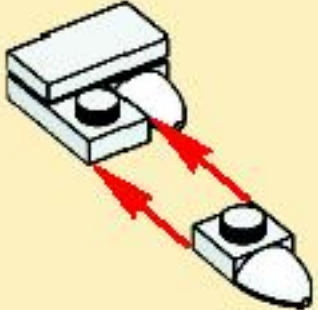

3

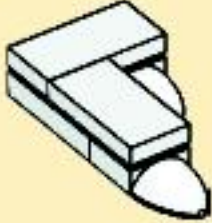

2x

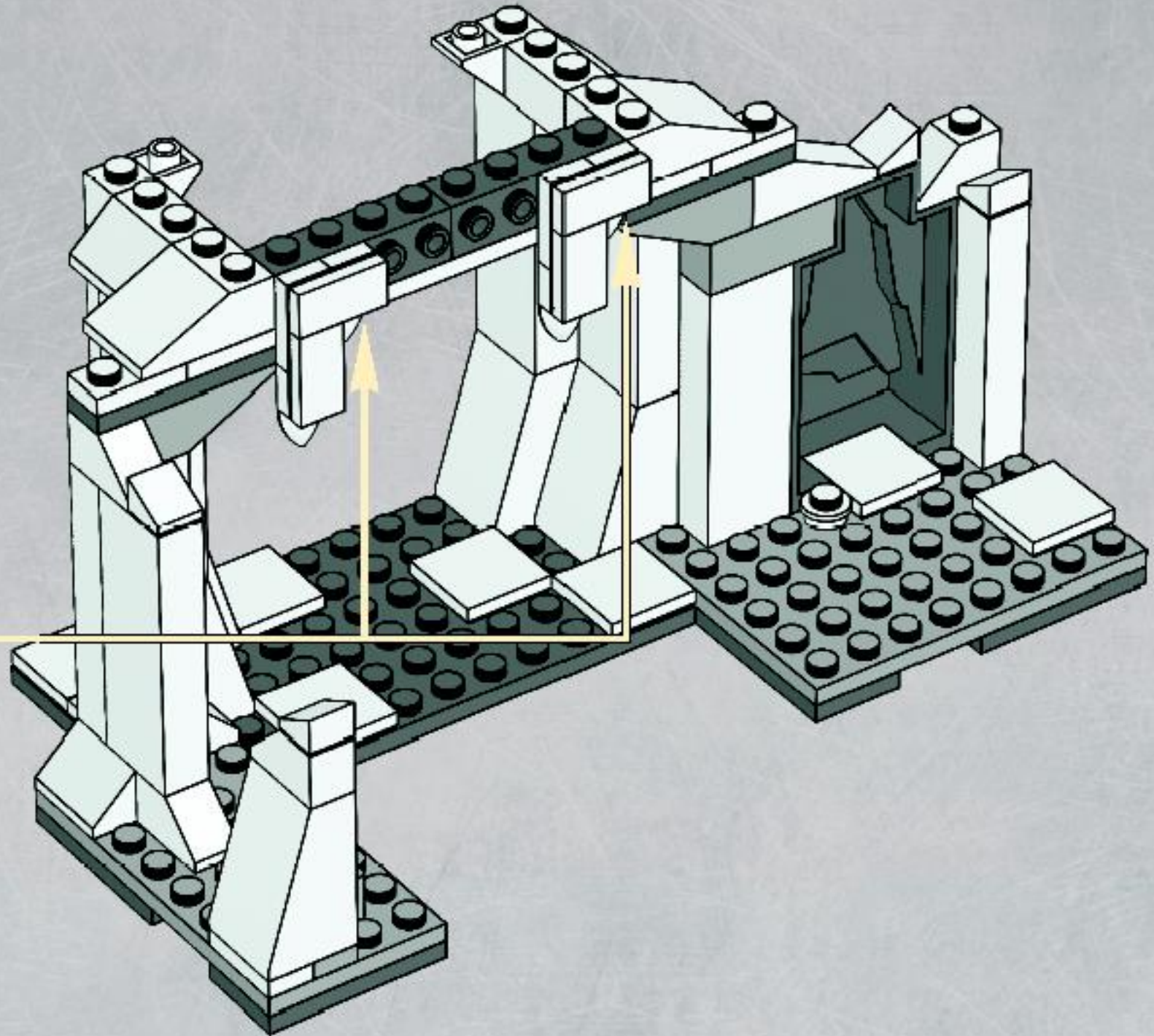



4x

19

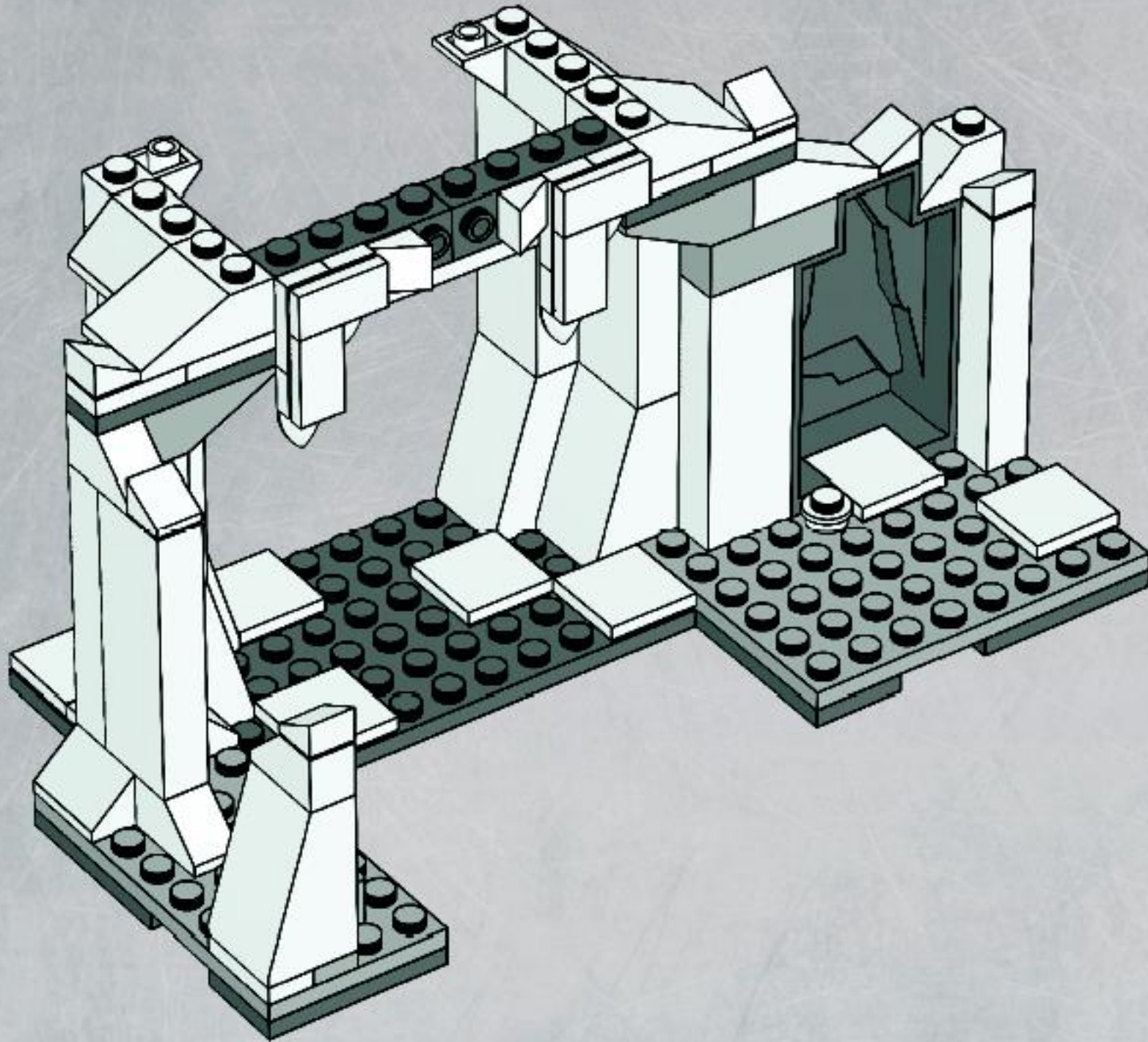

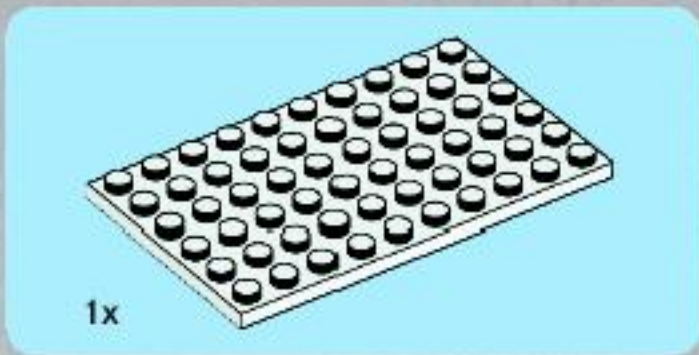

20

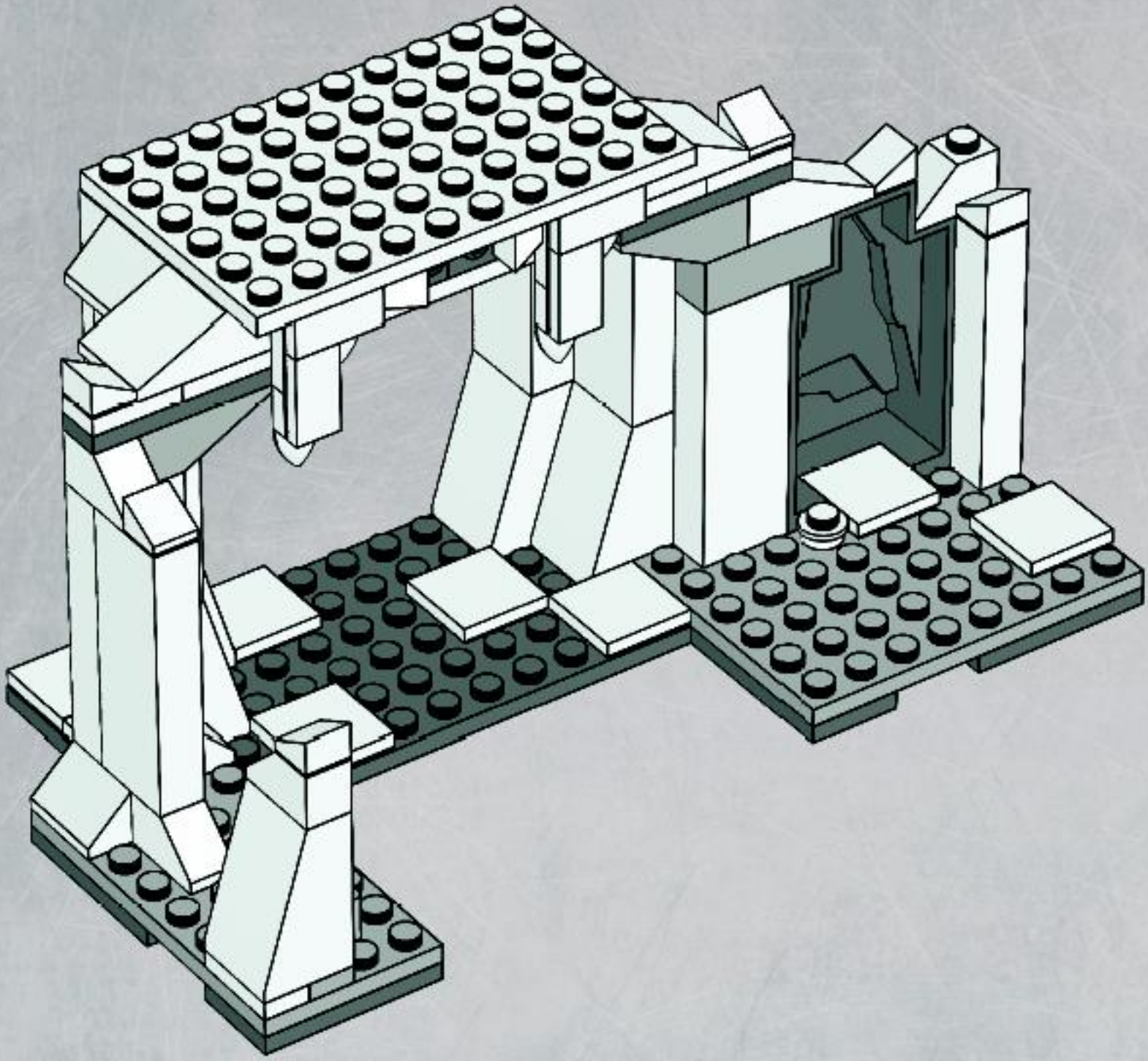



1x



2x



2x

21

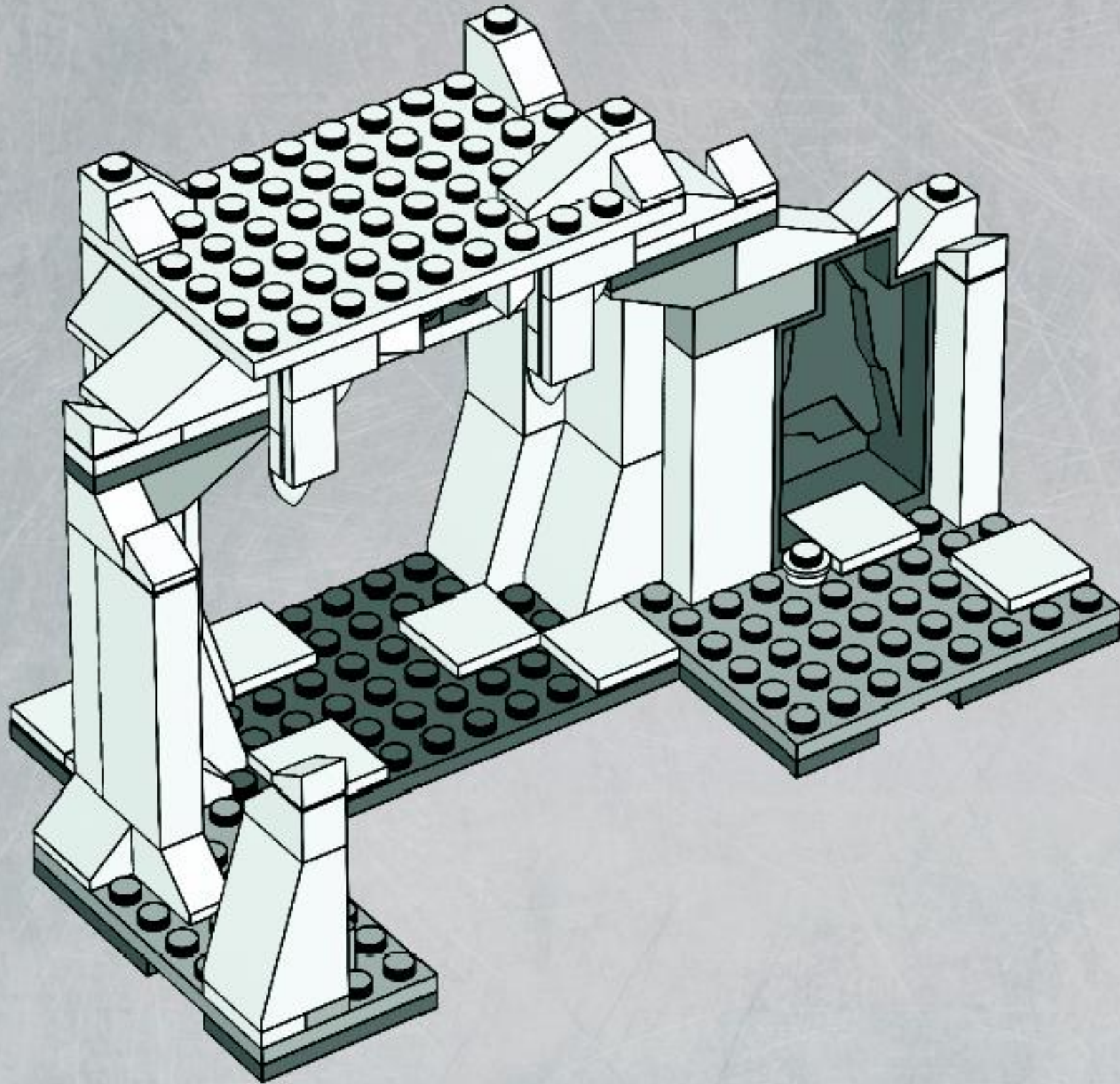

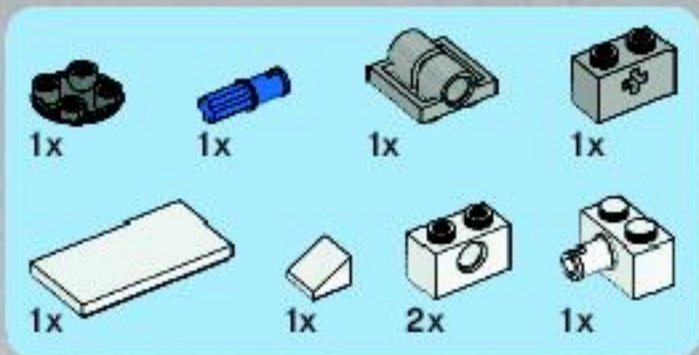

22

1

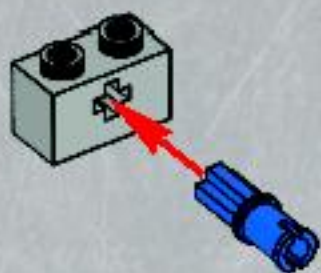

2



3

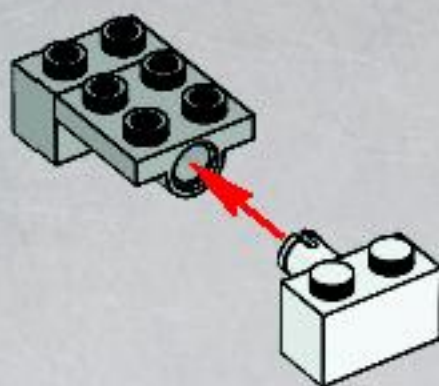

4

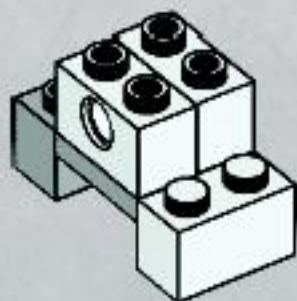

5

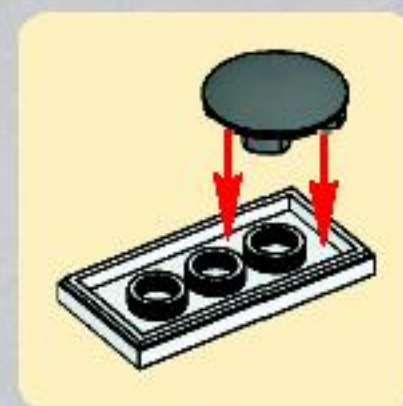
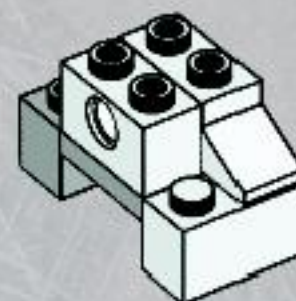

6

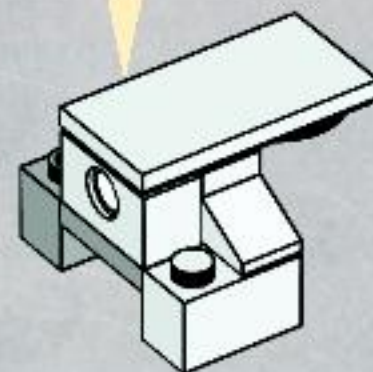

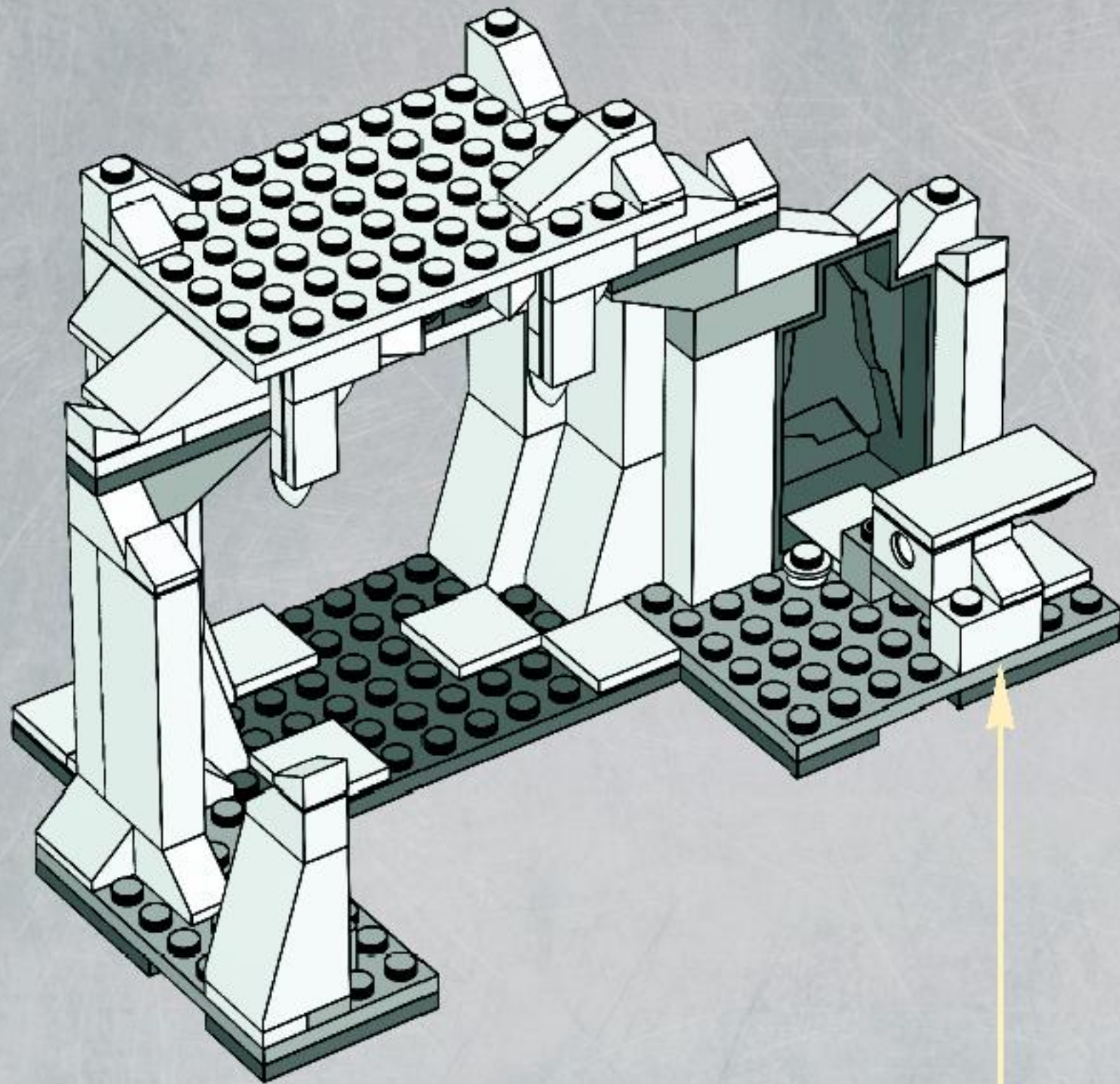



7x



4x



1x



8x

23

1

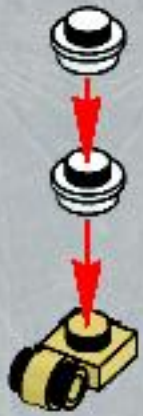

3



5

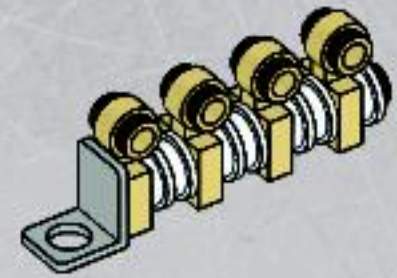

2



4



6

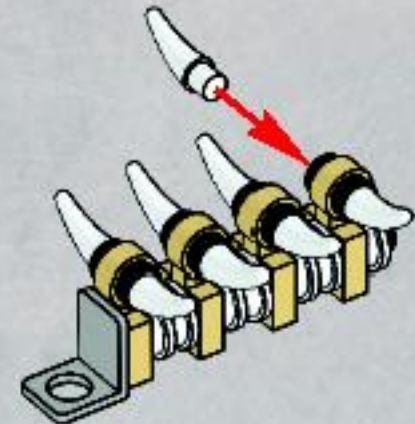

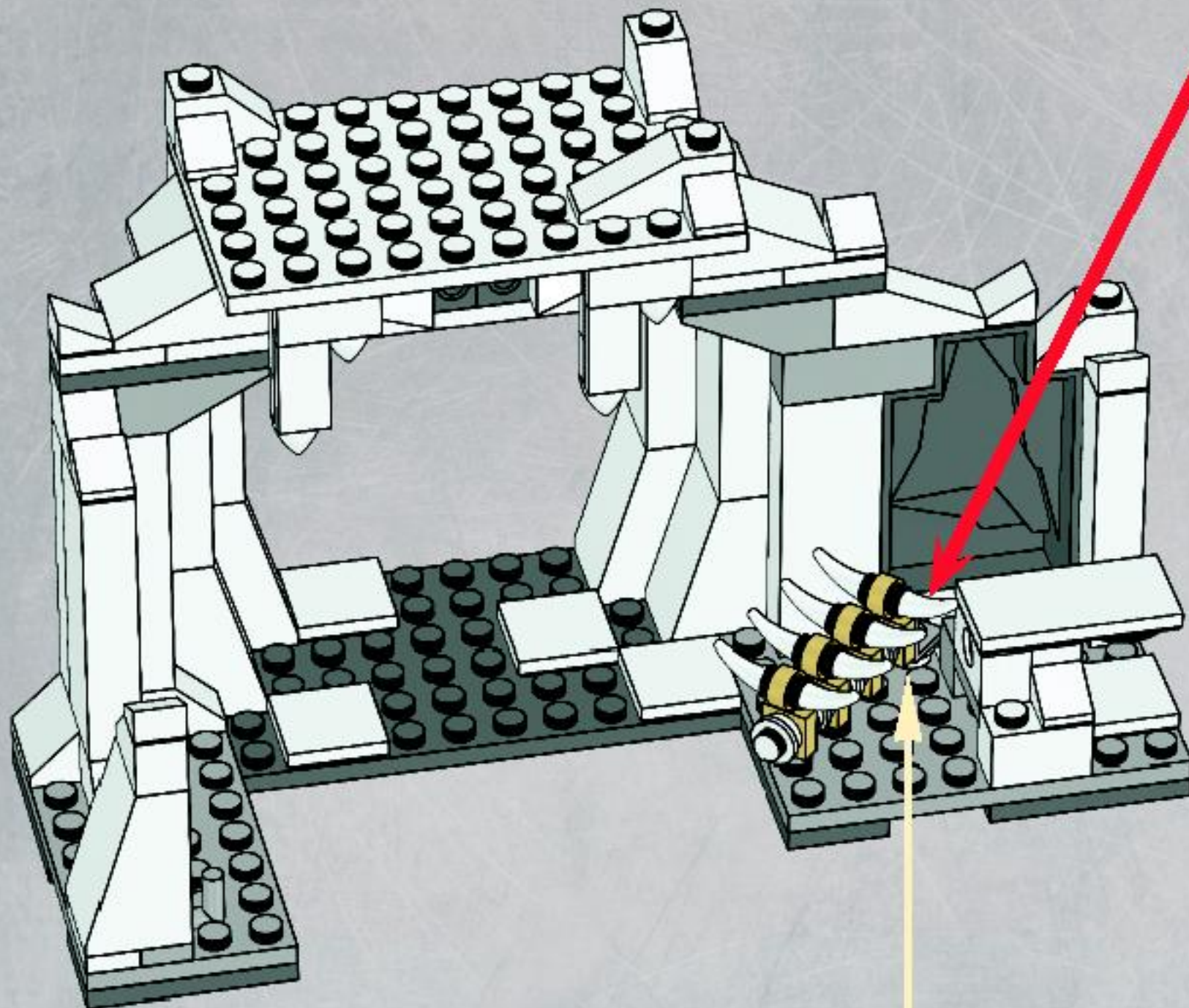

24

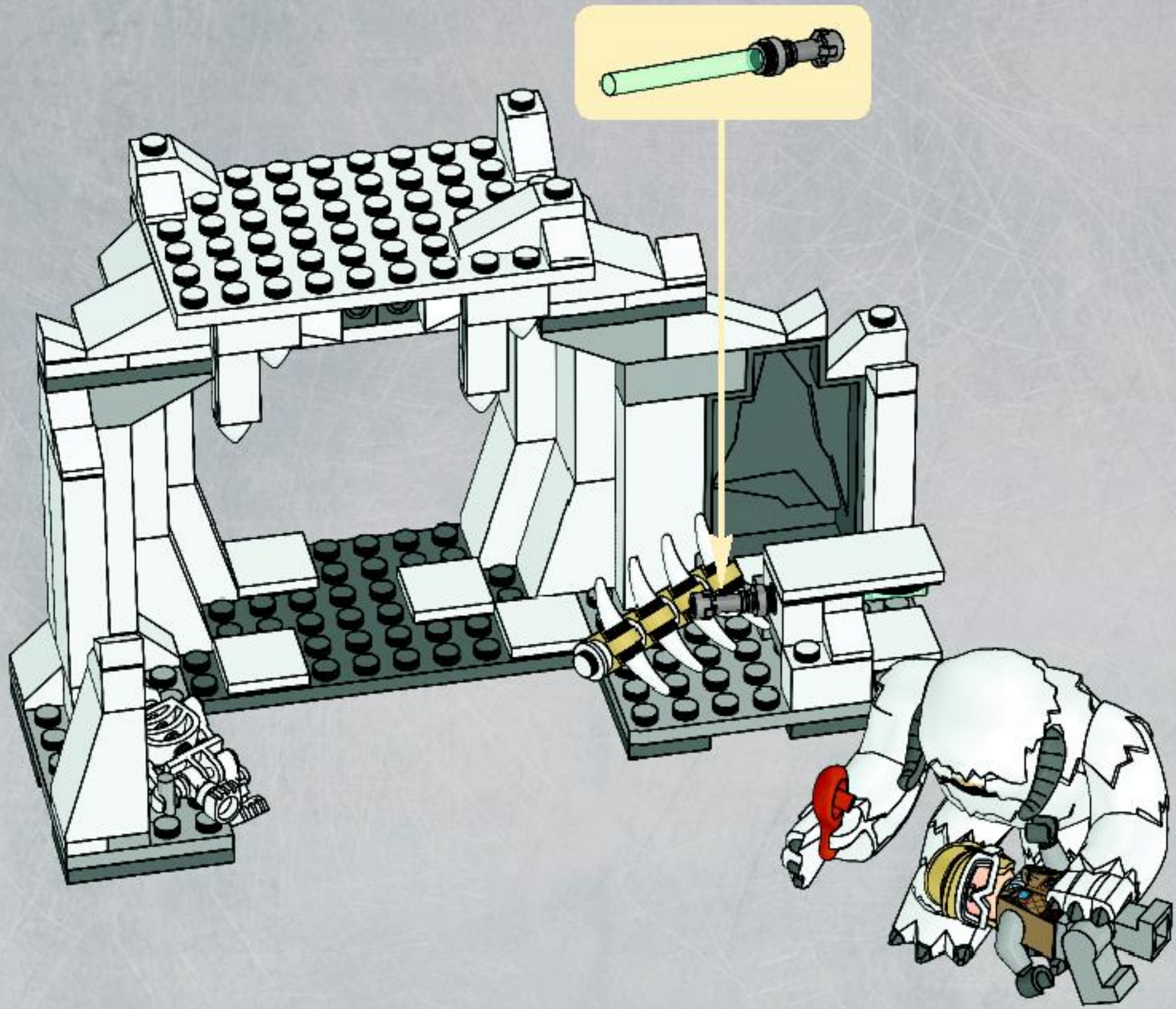

25

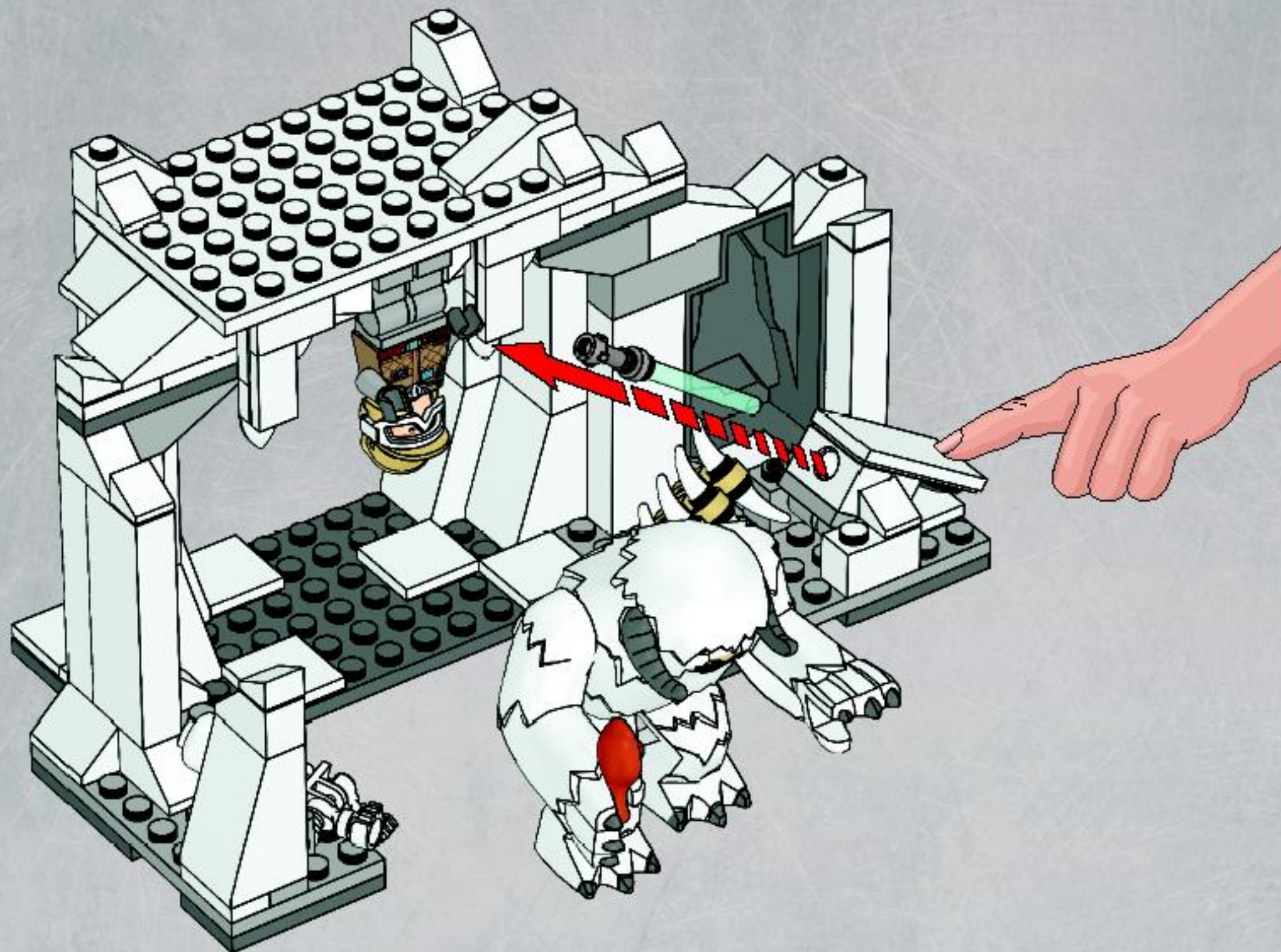

26

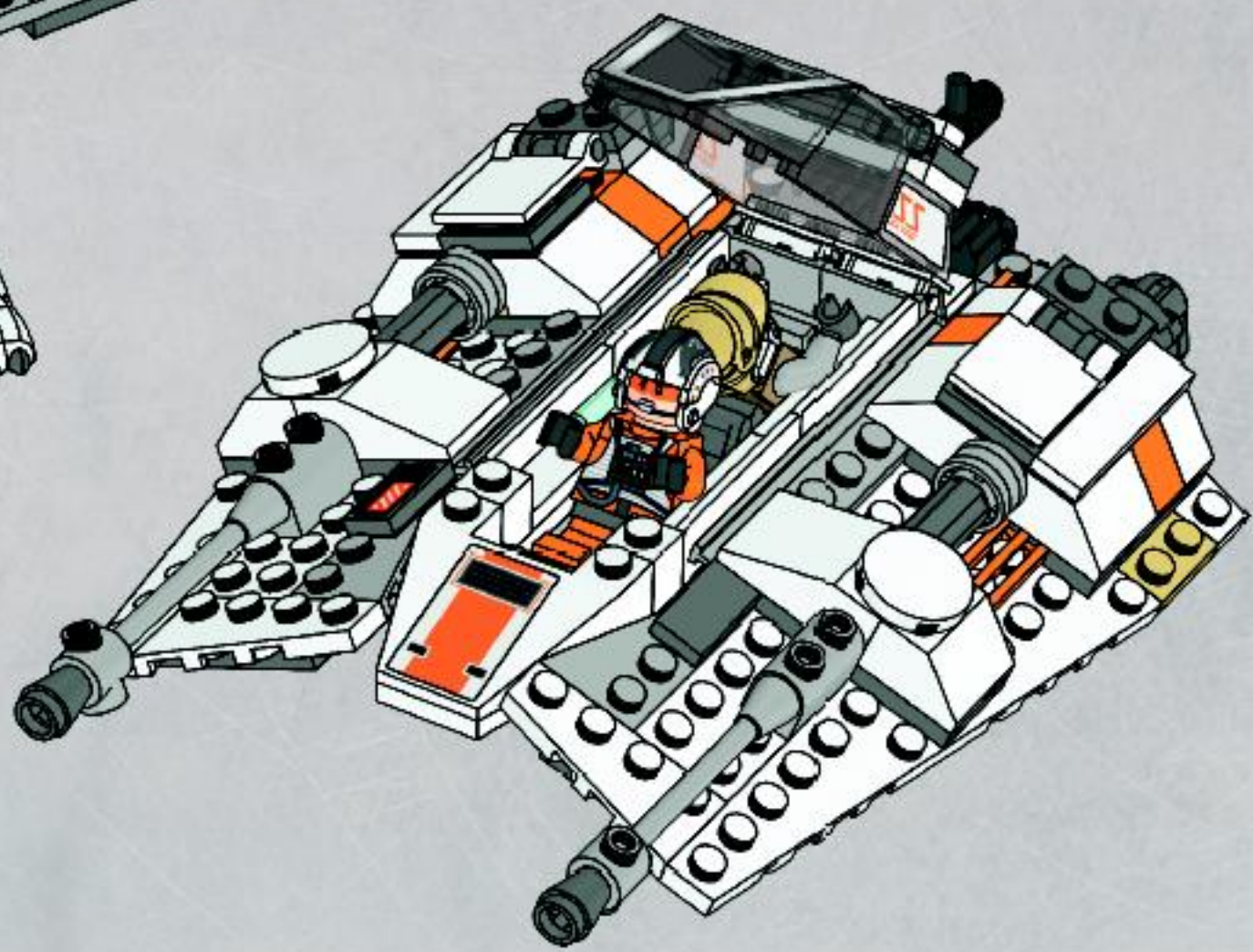
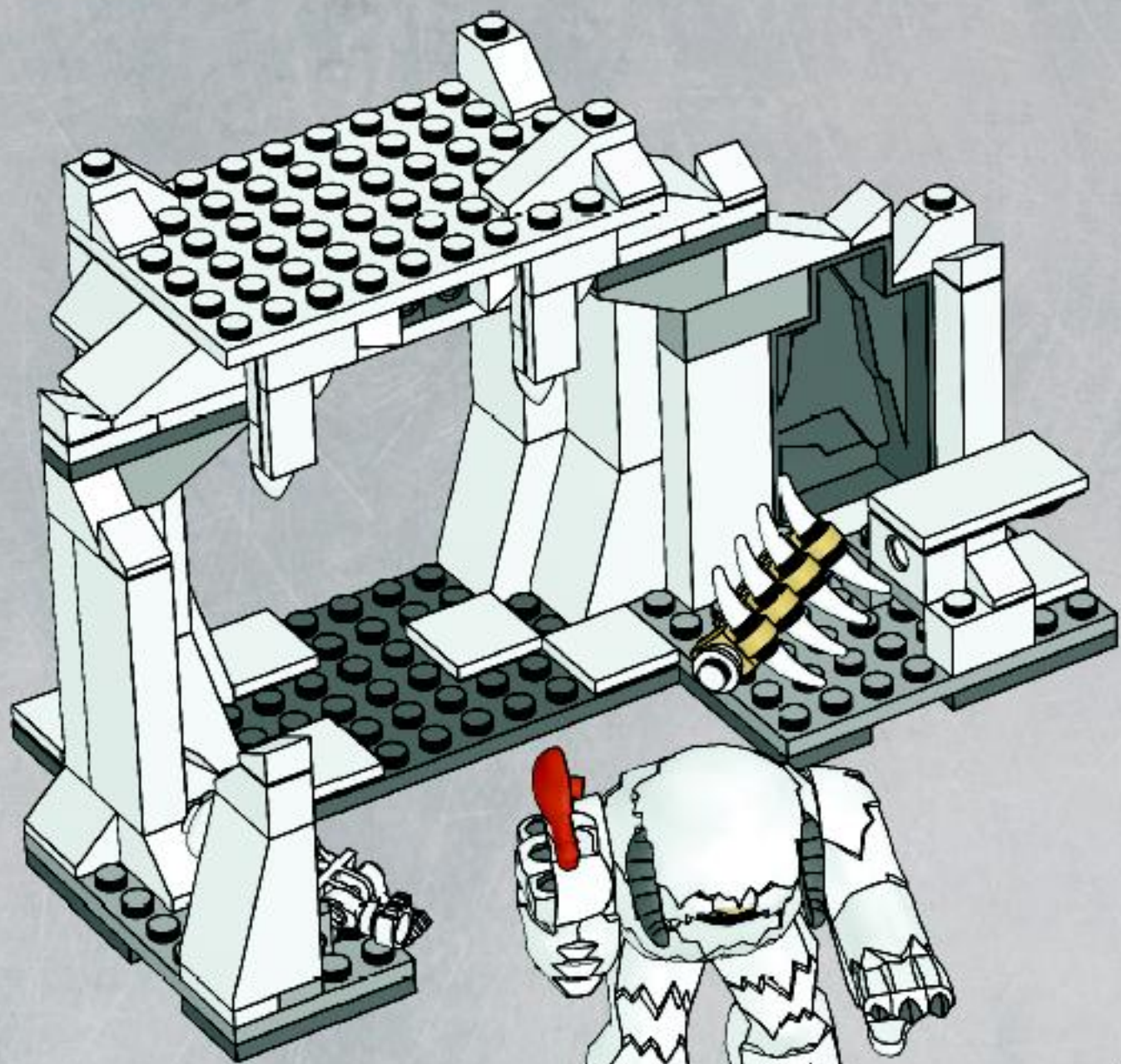

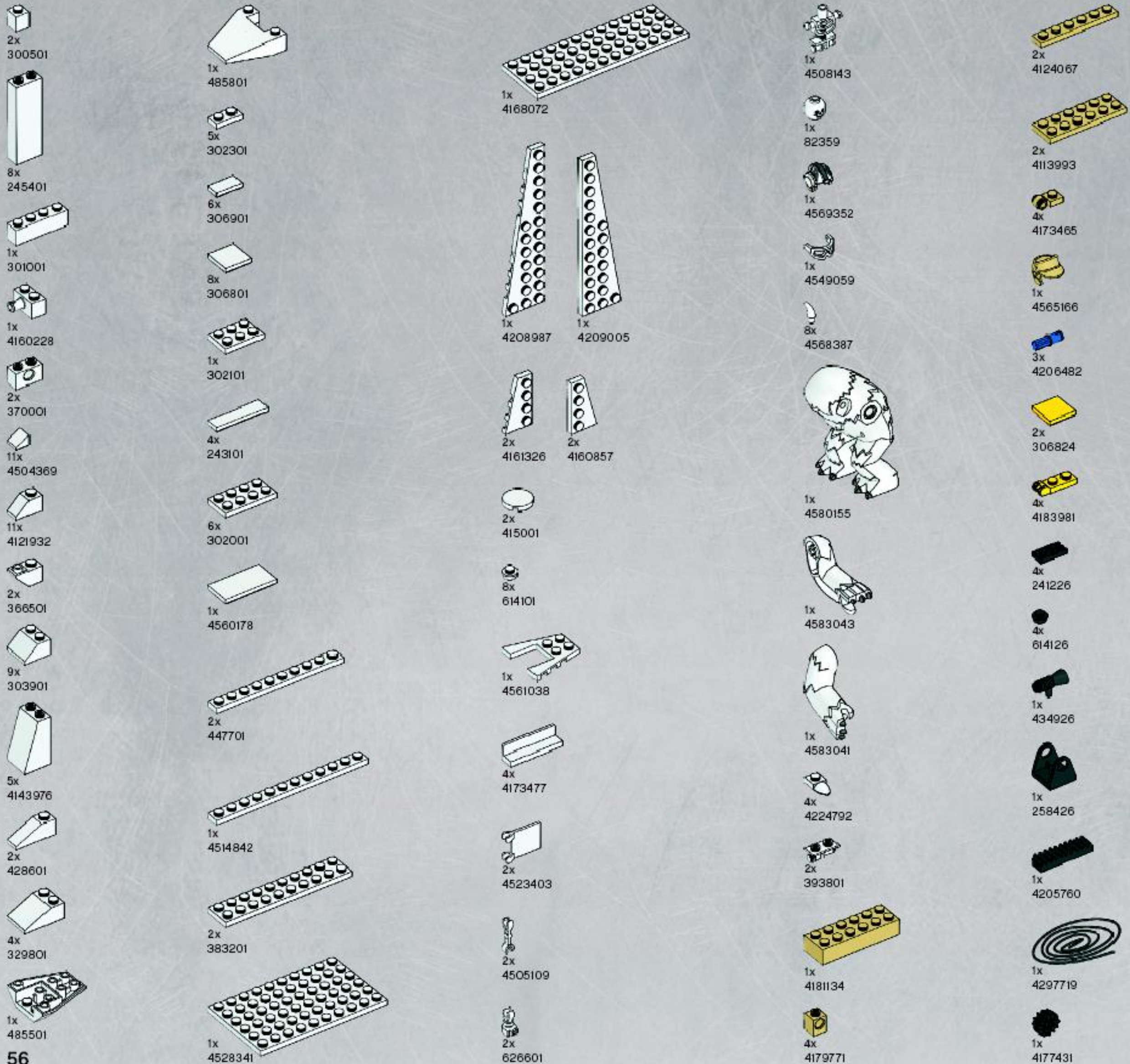



Customer Service
 Kundenservice
 Service Consommateurs
 Servicio Al Consumidor

www.lego.com/service or dial



: 00800 5346 5555

: 1-800-422-5346





8093



8095



8096



8097



8098



WIN!

Go to www.nielsen.com/LEGO to fill out a survey for a chance to win a cool LEGO® Product. No purchase necessary. Open to all residents where not prohibited.



www.nielsen.com/LEGO

GEWINNE! WIN!

Nimm an der Umfrage auf www.nielsen.com/ LEGO teil und hab die Chance ein cooles LEGO® Produkt zu gewinnen!

Die Teilnahme am Gewinnspiel führt zu keinerlei Kaufverpflichtungen. Teilnahme in allen nicht ausgeschlossenen Ländern möglich.

Ga naar www.nielsen.com/LEGO, vul een enquêteformulier in en maak kans op een cool LEGO® product.

Geen aankoopverplichting. Iedereen mag deelnemen, uitgezonderd ingezetenden van landen waar een enquêteverbod geldt.

GAGNE! 当てよう!

Visite www.nielsen.com/LEGO pour répondre à un questionnaire et avoir une chance de gagner un produit LEGO® très cool!

Aucune obligation d'achat. Ouvert à tous les résidents des pays autorisés.

www.nielsen.com/LEGOにアクセスして、アンケートにご記入ください。当選者にはレゴ製品を差し上げます。

お買い上げの必要はありません。禁止されていない限り、すべての年齢にご利用いただけます。