



**BMW
MOTORRAD**



Booklet available in English on
Livret disponible en français sur
Folleto disponible en español en



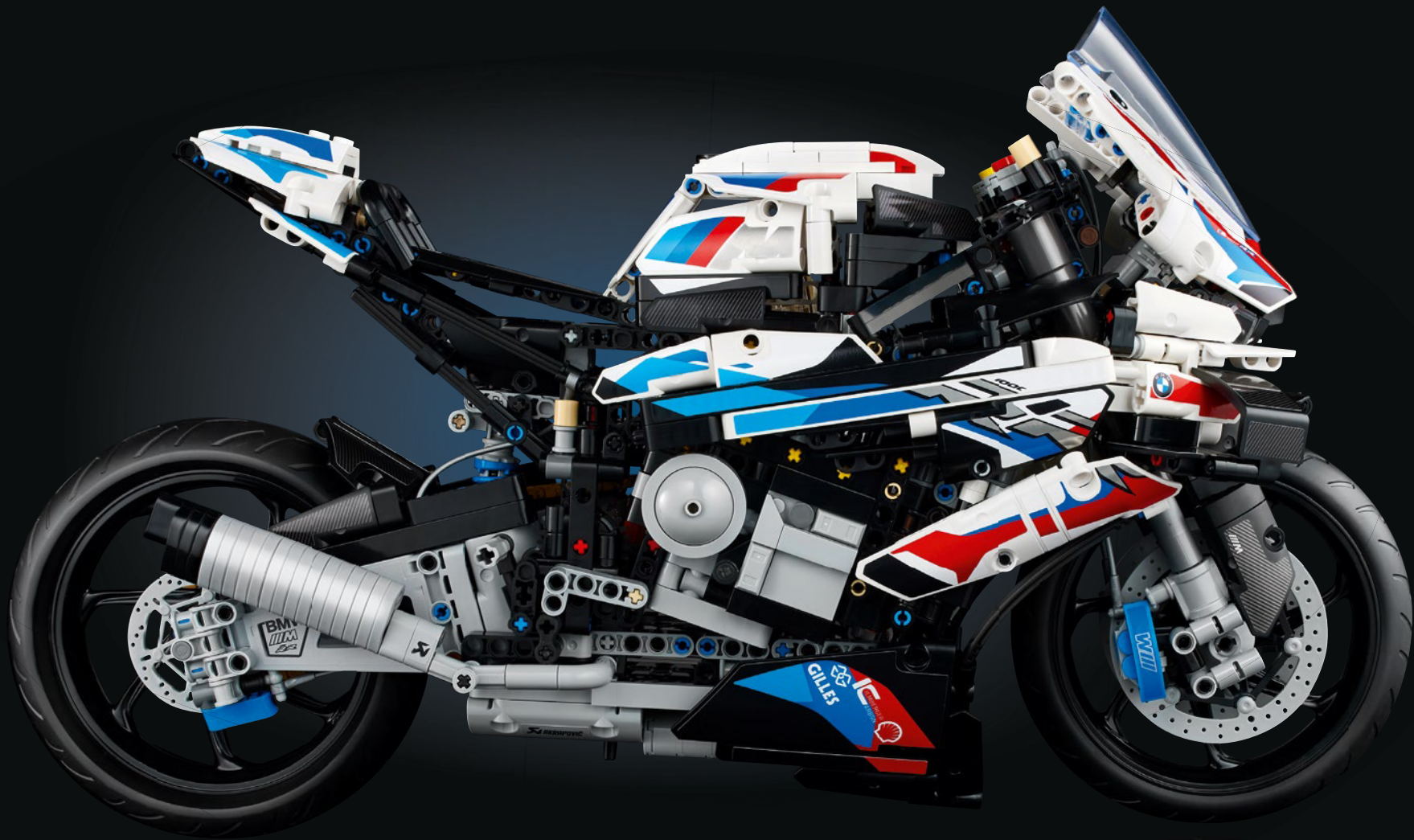



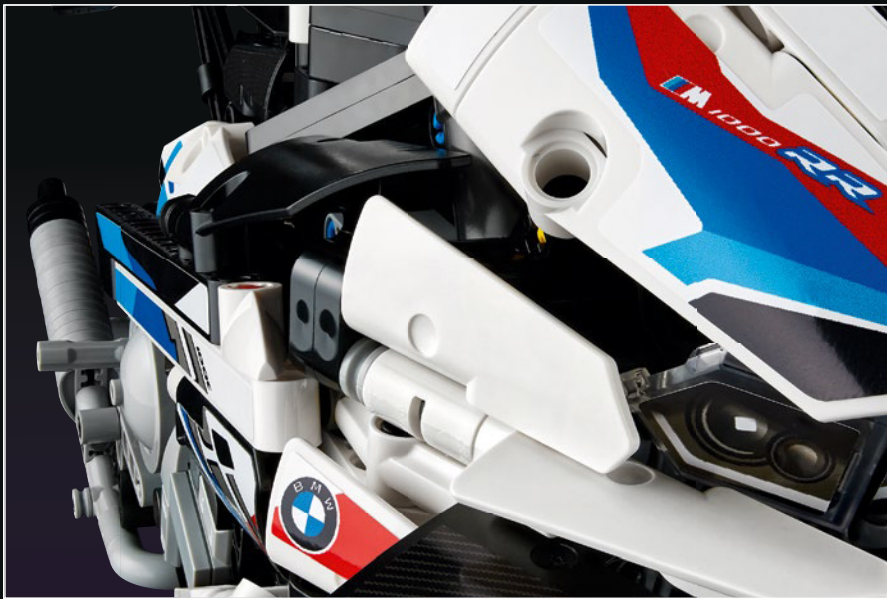
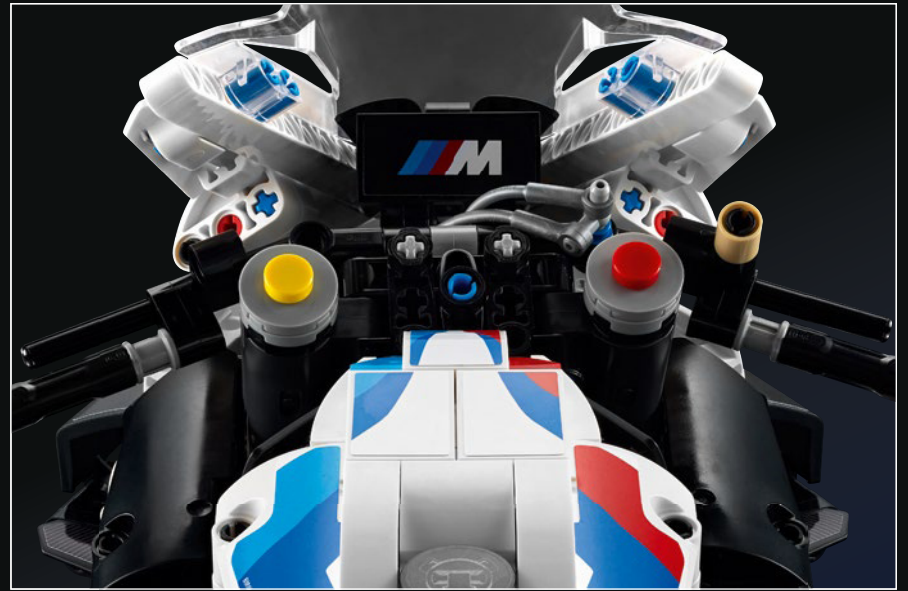

BMW M 1000 RR

When BMW Motorrad's in-house performance experts announced the first-ever M-developed motorcycle, the BMW M RR, everyone knew that the result was going to be something special. In the same way, the LEGO® Technic™ team realized it would take something never seen before to pay true tribute to the M RR. The result is both a motorcycle and a Technic model that are state-of-the-art within their respective fields.

Lorsque les experts en performance de BMW Motorrad ont annoncé la toute première moto développée par Motoradd, la BMW M RR, il était évident que le résultat serait vraiment spécial. Ainsi, l'équipe LEGO® Technic™ a réalisé qu'il faudrait quelque chose d'unique en son genre pour rendre hommage à la M RR. Le résultat est une moto et un modèle Technic qui sont à la fine pointe de la technologie dans leurs domaines respectifs.

Cuando los expertos en desempeño de BMW Motorrad anunciaron la primera moto de la serie M, la BMW M RR, todo el mundo supo que el resultado sería algo especial. De igual manera, el equipo de LEGO® Technic™ se dio cuenta de que haría falta algo nunca antes visto para rendir un verdadero homenaje a la M RR. El resultado es una motocicleta y un modelo Technic a la vanguardia en sus respectivos campos.





THE PINNACLE OF PERFORMANCE **LE SUMMUM DE LA PERFORMANCE** **LA CÚSPIDE DEL DESEMPEÑO**

The quest for enhanced performance on both racetrack and road is what defines this M version of a high-performance motorcycle. With the original RR superbike as the perfect foundation, the BMW Motorrad team set about coaxing more power out of the water-cooled 999-cc inline four-cylinder engine, while also introducing design upgrades like carbon fiber wheels and a titanium exhaust system to reduce overall weight.

La quête de performance accrue sur piste comme sur route est ce qui définit cette version M d'une moto haute performance. Avec la super moto RR originale comme base parfaite, l'équipe de BMW Motorrad a entrepris de tirer plus de puissance du moteur quatre cylindres en ligne refroidi par eau d'une cylindrée de 999 cm³, tout en ajoutant des améliorations de conception comme des roues en fibre de carbone et un système d'échappement en titane pour réduire le poids total.

La búsqueda del máximo desempeño tanto en la pista de carreras como en la carretera constituye la auténtica esencia de esta versión M de una motocicleta de altas prestaciones. Con la supermoto RR original como base perfecta, el equipo de BMW Motorrad se propuso sacar más potencia del motor de cuatro cilindros en línea de 999 cc refrigerado por agua, introduciendo al mismo tiempo mejoras de diseño (como ruedas de fibra de carbono y un sistema de escape de titanio para reducir el peso total).





A MATTER OF SCALE **UN DÉFI DE TAILLE** **UNA CUESTIÓN DE ESCALA**

The first challenge the LEGO® Technic™ designers faced was to set the scale of the model. Too small and it would be difficult to replicate the many features and functions of the real M RR. Too big and it would challenge the Technic building system. With a 1:5 scale, it became the largest Technic motorcycle model ever created. The Technic team worked closely with the designers and engineers at BMW Motorrad to ensure the LEGO Technic version was as close to the real M RR as possible.

Le premier défi que les concepteurs LEGO® Technic™ ont rencontré a été de définir l'échelle du modèle. Trop petite, les nombreuses caractéristiques et fonctions de la vraie M RR seraient difficiles à reproduire. Trop grande, le système de construction Technic serait mis à l'épreuve. Avec une échelle de 1:5, c'est le plus grand modèle de moto Technic jamais créé. L'équipe de conception de LEGO Technic a travaillé en étroite collaboration avec les concepteurs et les ingénieurs de BMW Motorrad pour assurer que la version LEGO Technic de la M RR imite le plus fidèlement possible la vraie moto.

El primer desafío que enfrentaron los diseñadores de LEGO® Technic™ fue establecer la escala del modelo. De ser demasiado pequeña, reproducir las numerosas características y funciones de la verdadera M RR resultaría muy complicado. De ser demasiado grande, el sistema de construcción Technic se vería en problemas. Con una escala 1:5, este modelo de motocicleta Technic se convirtió en el más grande que se haya creado. El equipo de Technic trabajó hombro a hombro con los diseñadores e ingenieros de BMW Motorrad para asegurarse de que la versión LEGO Technic fuera lo más parecida posible a la M RR de verdad.

SAMUEL TACCHI
Designer/ Concepteur/
Diseñador
LEGO® Technic™



“

IT TOOK ME BACK TO WHEN I WAS DESIGNING MOTORCYCLES.”

« CELA M'A RAMENÉ À L'ÉPOQUE OÙ JE CONCEVAIS DES MOTOS. »

“ME HIZO RECORDAR CUANDO DISEÑABA MOTOS”.

Samuel Tacchi



With a background in motorcycle design and a huge passion for riding them as well, LEGO® Technic™ designer Samuel Tacchi was the natural choice to lead this project.

Vu son expérience dans la conception de motos et son énorme passion pour leur conduite, le concepteur LEGO® Technic™ Samuel Tacchi était tout désigné pour diriger ce projet.

Por su experiencia en el diseño de motocicletas y enorme pasión por conducir las, el diseñador de LEGO® Technic™ Samuel Tacchi era la mejor opción para dirigir el proyecto.

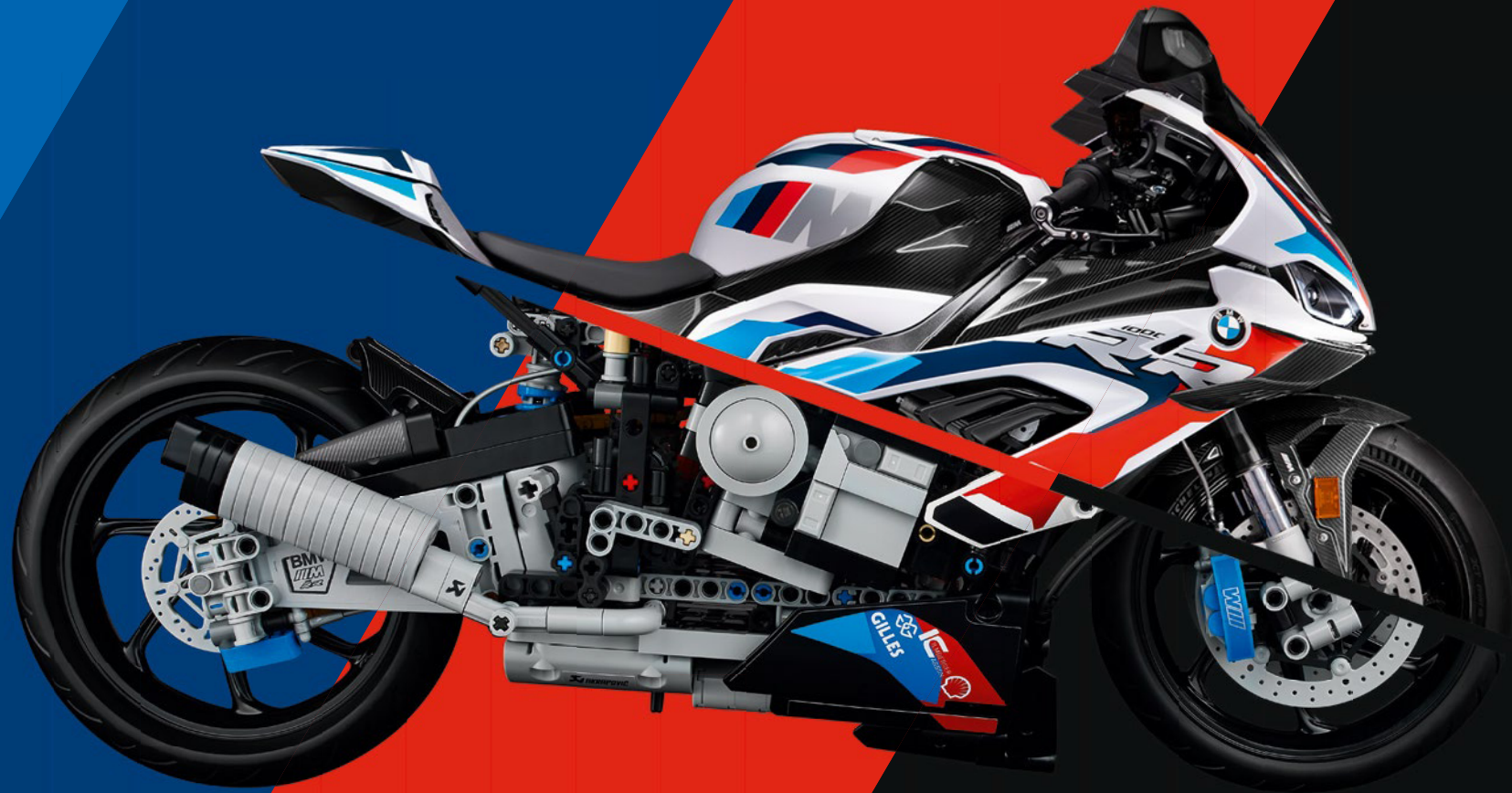

**PUSHING THE TECHNIC™ BUILDING SYSTEM
REPOUSSER LES LIMITES DU SYSTÈME DE
CONSTRUCTION TECHNIC™
UN DESAFÍO PARA EL SISTEMA DE CONSTRUCCIÓN TECHNIC™**

The Technic™ version of the M RR needed the design of eight new pieces and Senior Designer Daniel Sri Sudarsono oversaw this process. It started with the new front and rear suspension setup needed to support the 3 lbs. (1.4 kg) weight of the model. New rims, disc brakes and a transparent windshield quickly followed, all of which had to be tried and tested before being approved for use in the final model.

La version Technic™ de la M RR a nécessité la conception de huit nouvelles pièces. Le concepteur principal Daniel Sri Sudarsono a supervisé ce processus. Il a d'abord fallu reconfigurer la suspension avant et arrière pour supporter le poids de 1,4 kg du modèle. Ensuite, de nouvelles jantes, des freins à disque et un pare-brise transparent ont été ajoutés, puis essayés et testés avant d'être approuvés pour l'utilisation dans le modèle final.

La versión Technic™ de la M RR requirió el diseño de ocho nuevas piezas, un proceso que fue supervisado por el diseñador sénior Daniel Sri Sudarsono. Comenzó con la estructura para la nueva suspensión delantera y trasera, necesaria para soportar los 1,4 kg de peso del modelo. Le siguieron rápidamente nuevos rines, frenos de disco y un parabrisas transparente, todo lo cual tuvo que superar numerosas pruebas antes de recibir la aprobación necesaria para formar parte del modelo final.



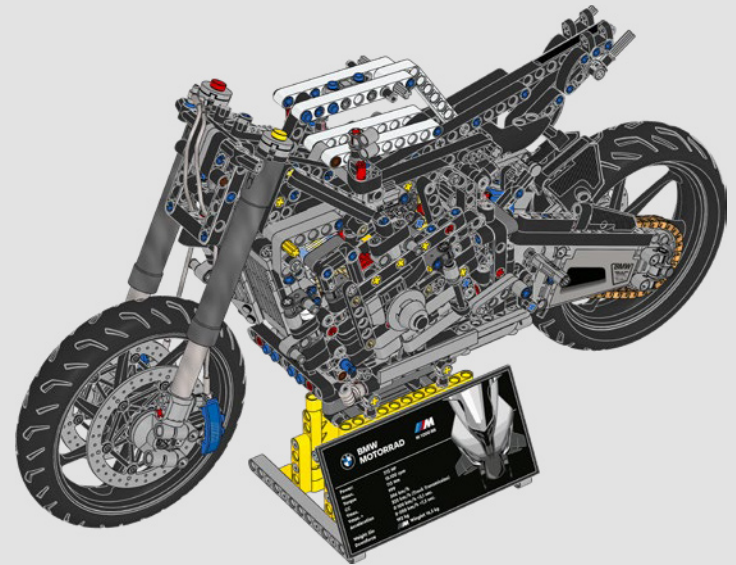
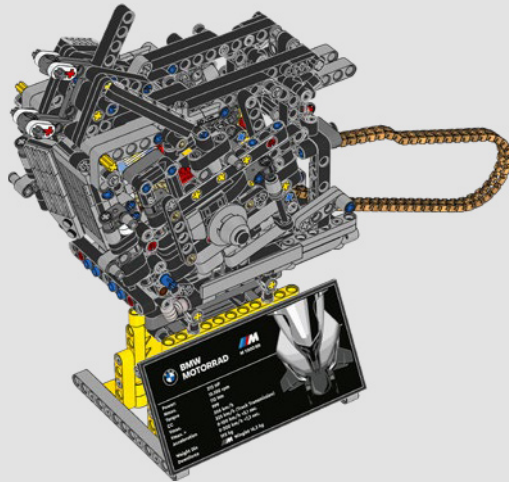
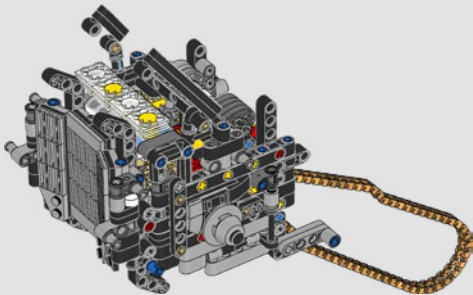
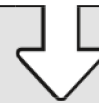
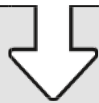
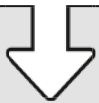

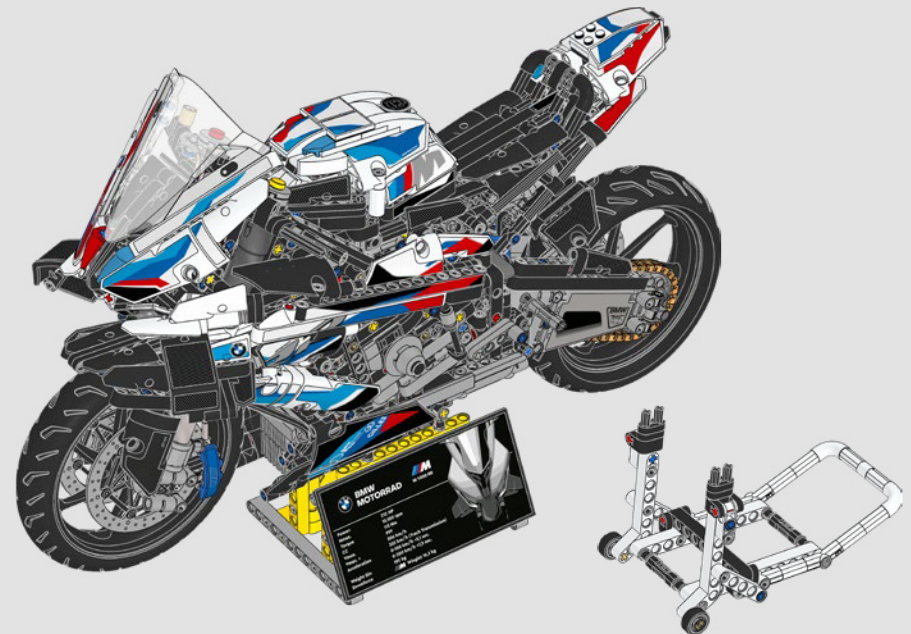
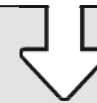
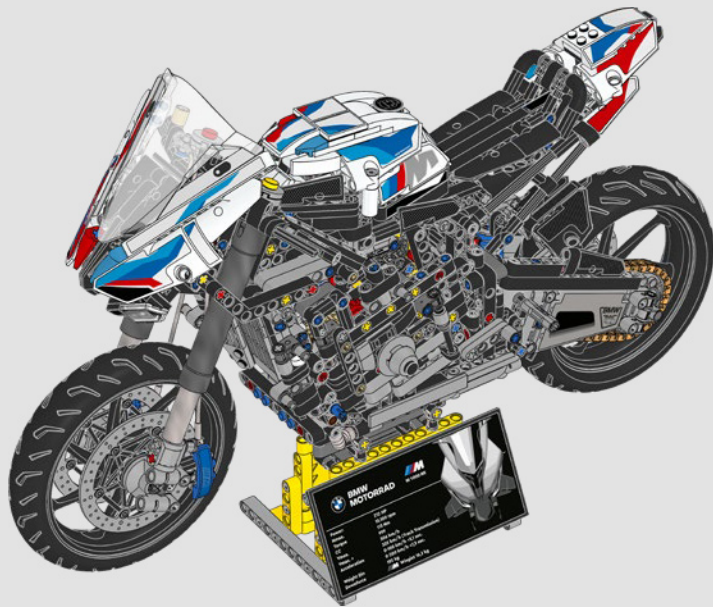
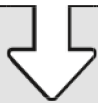

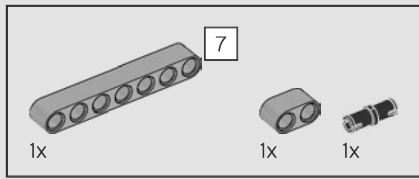
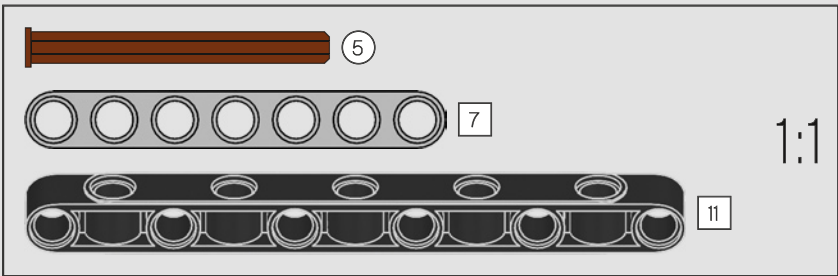
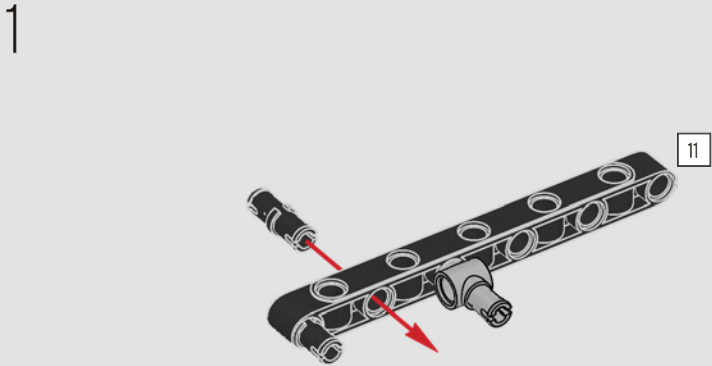
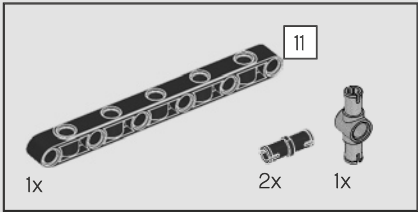
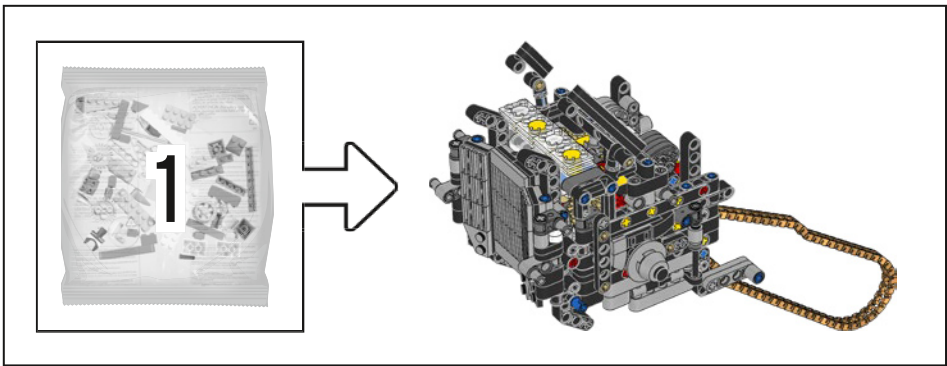

2

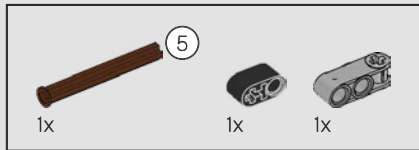
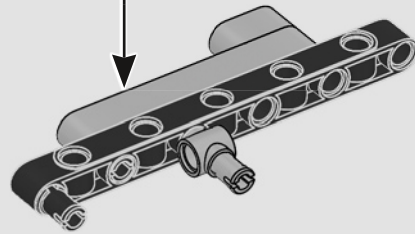
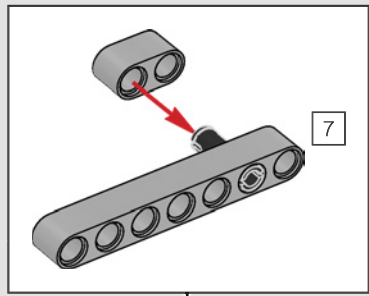

3

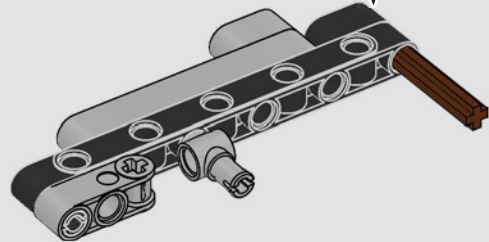
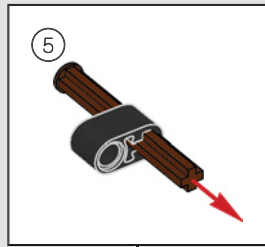



4

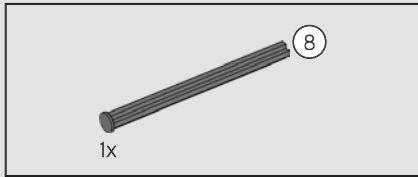
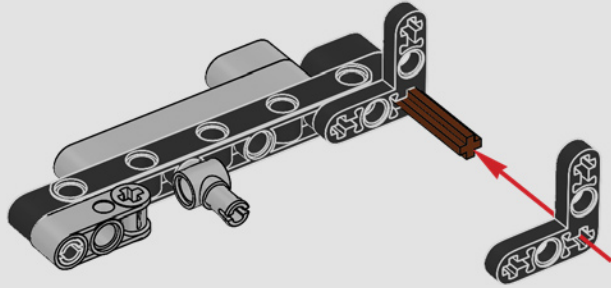

5

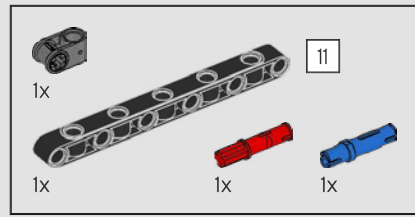
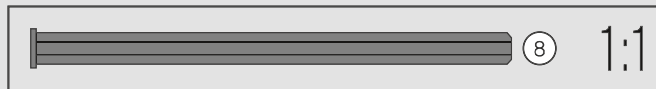
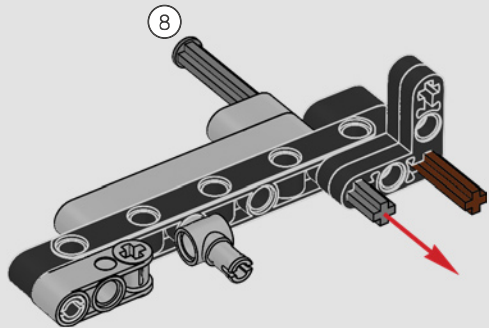

6

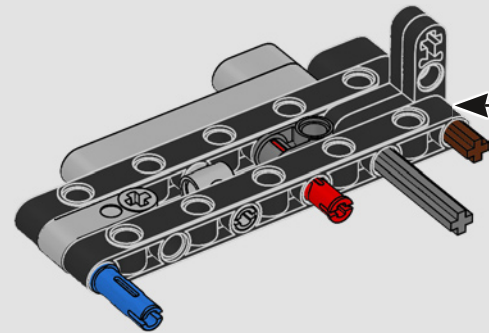
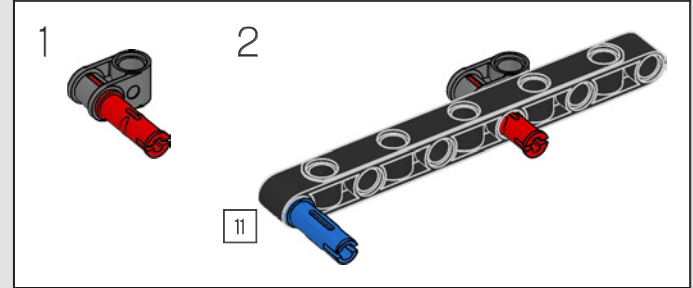

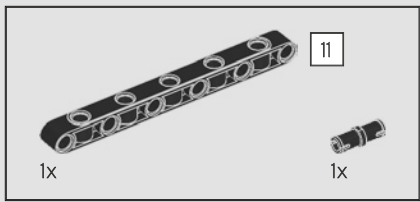

7

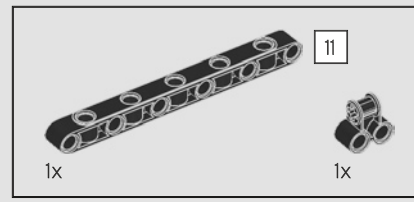
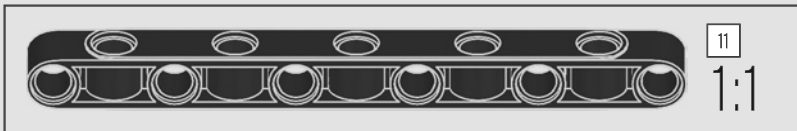
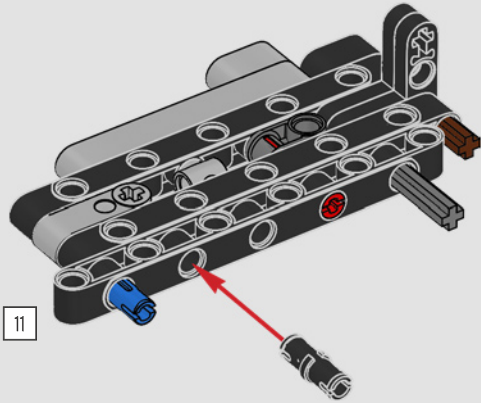

8

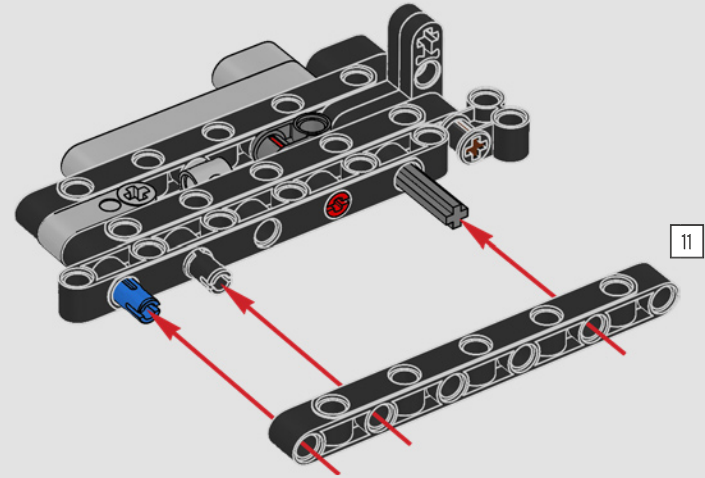

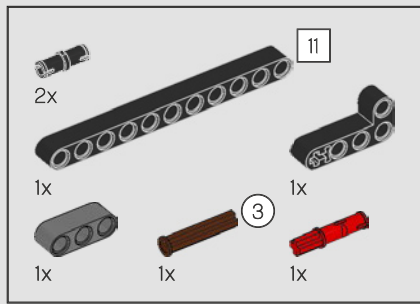

9

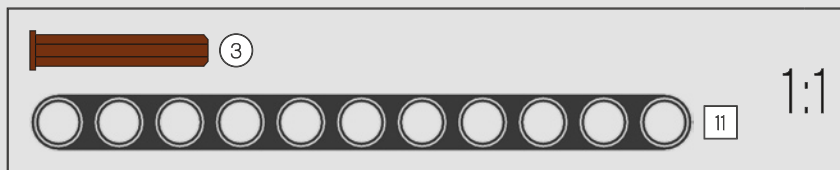
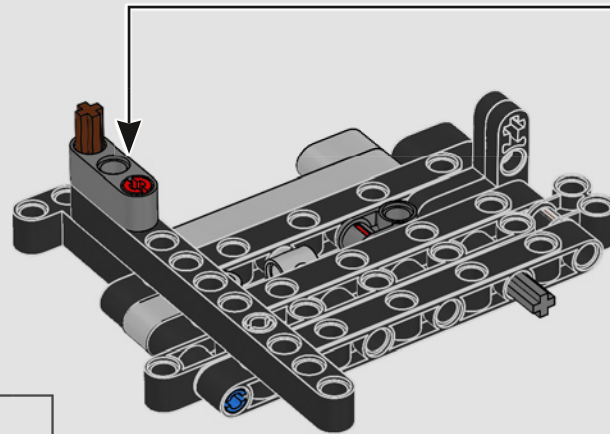
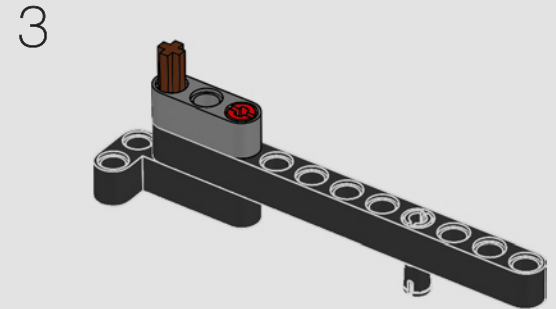
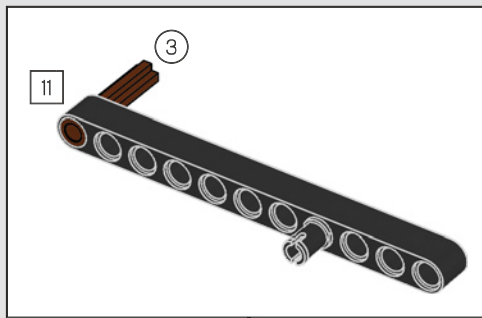
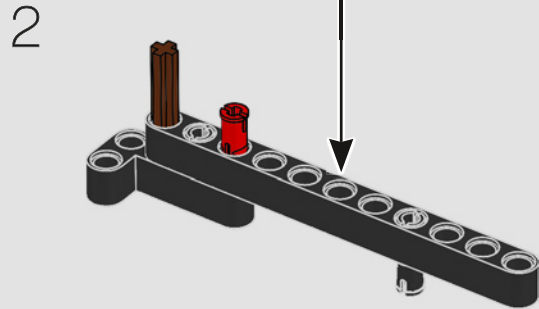
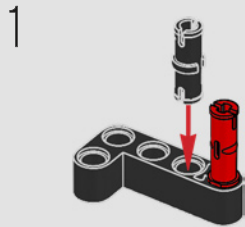

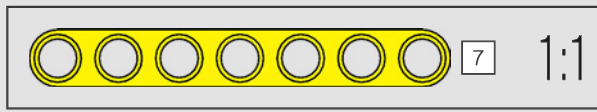
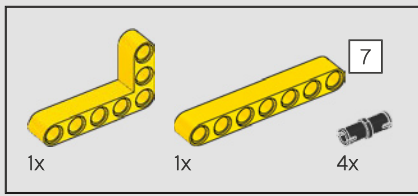

10

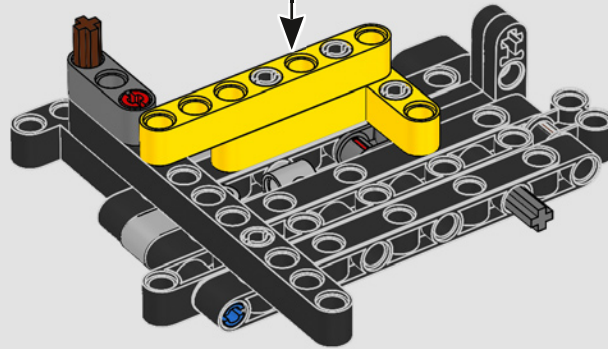
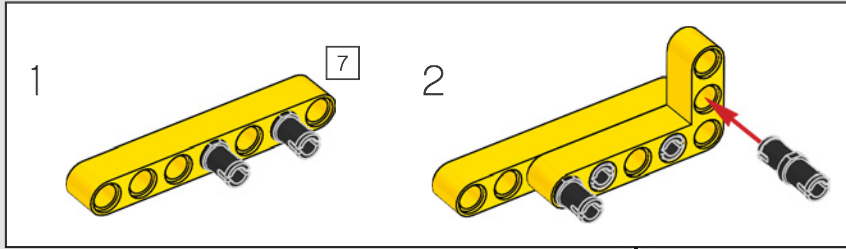

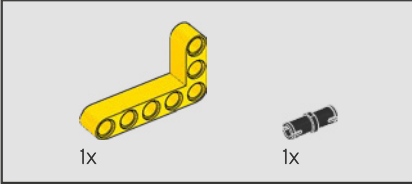
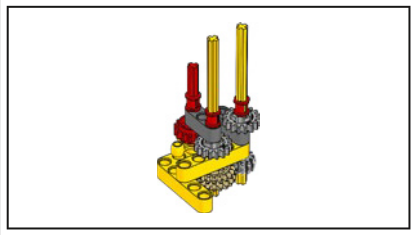

11

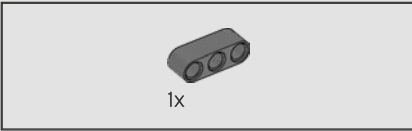
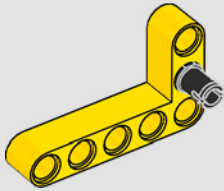

12

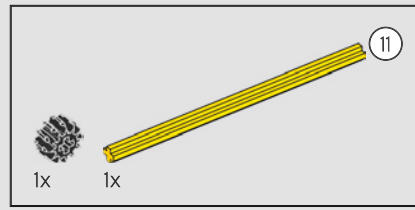
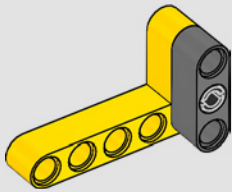

13

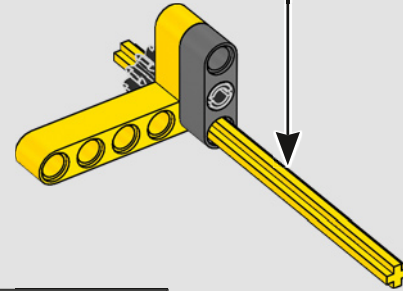
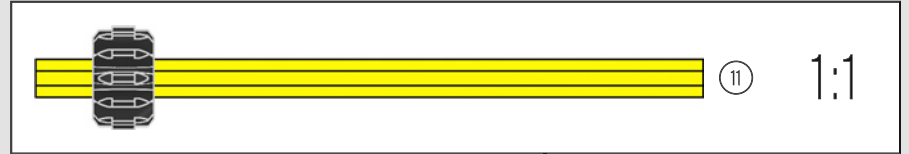

14

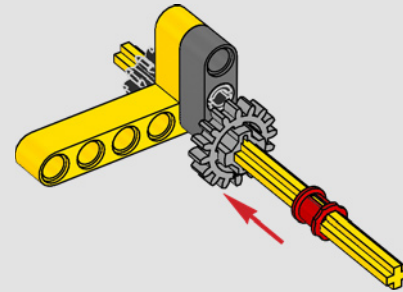

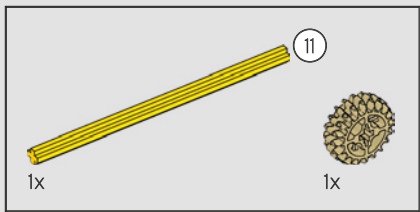

15

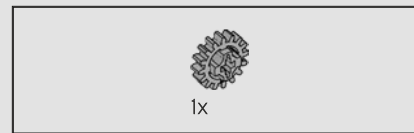
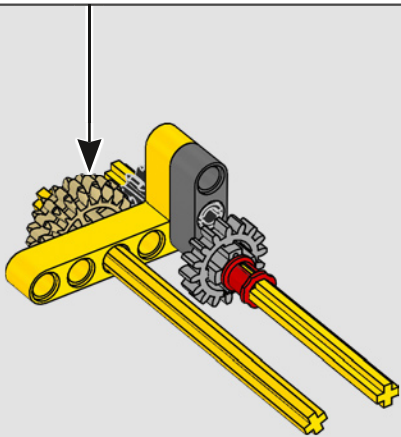
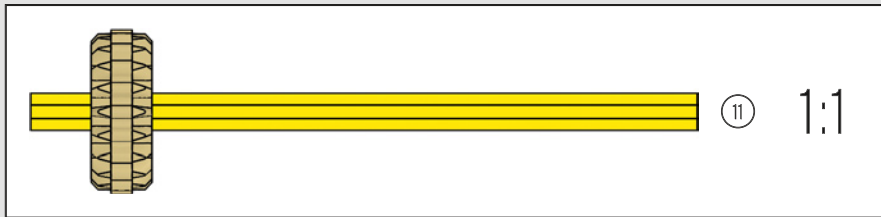

16

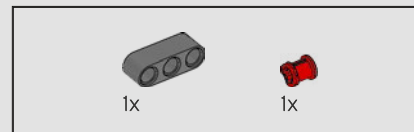
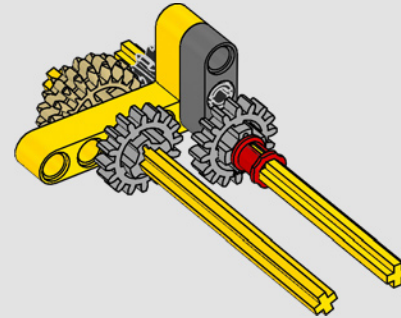

17

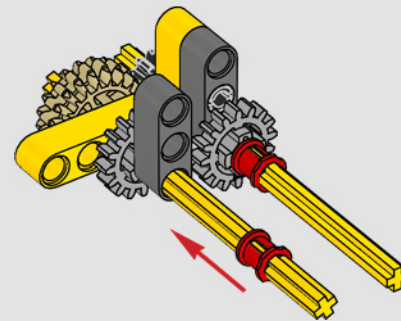

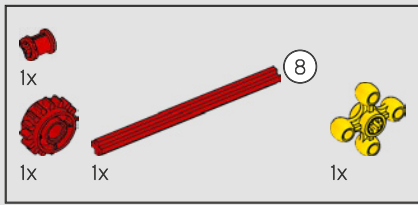

18

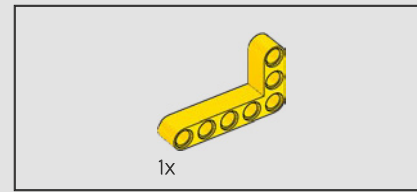
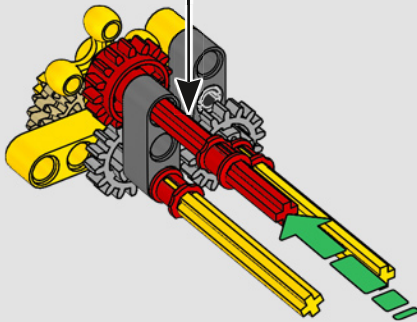
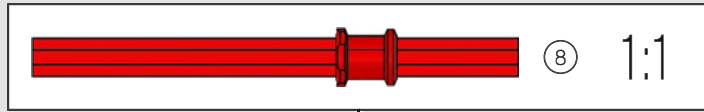

19

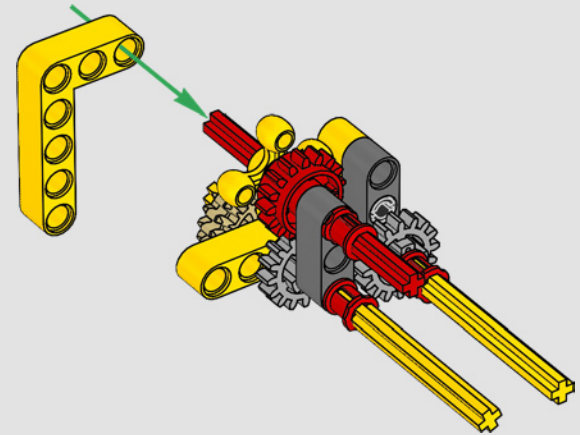

20

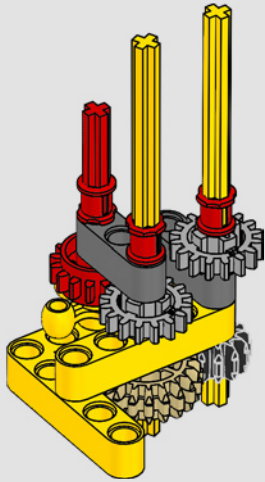

21

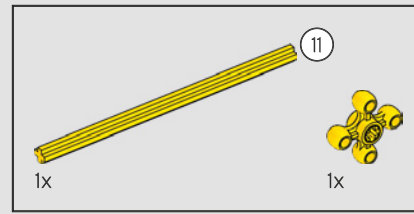
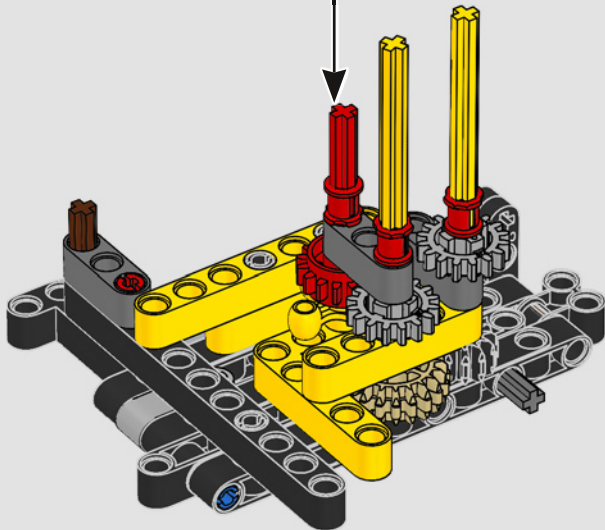

22

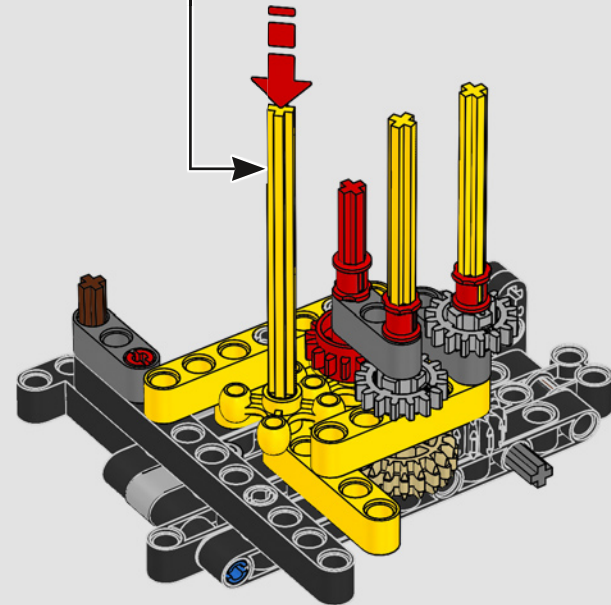
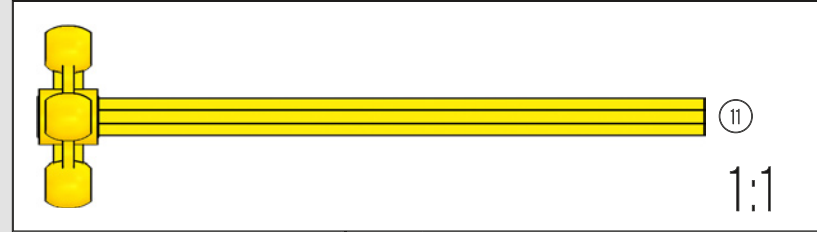

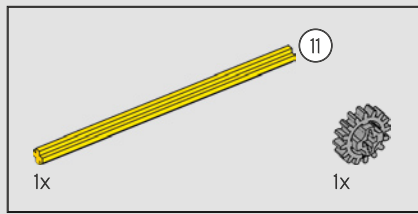

23

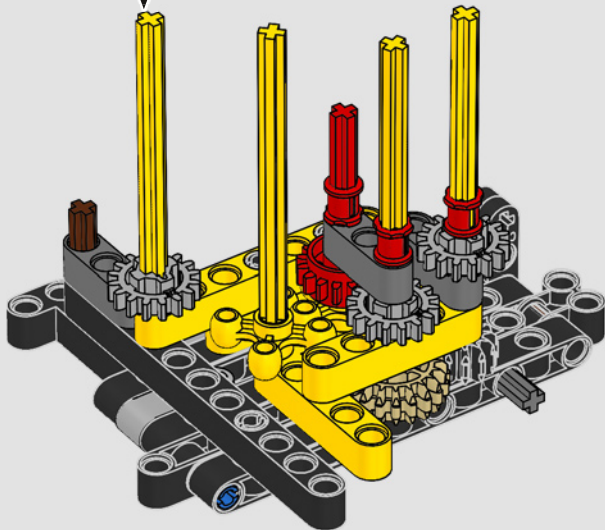

24

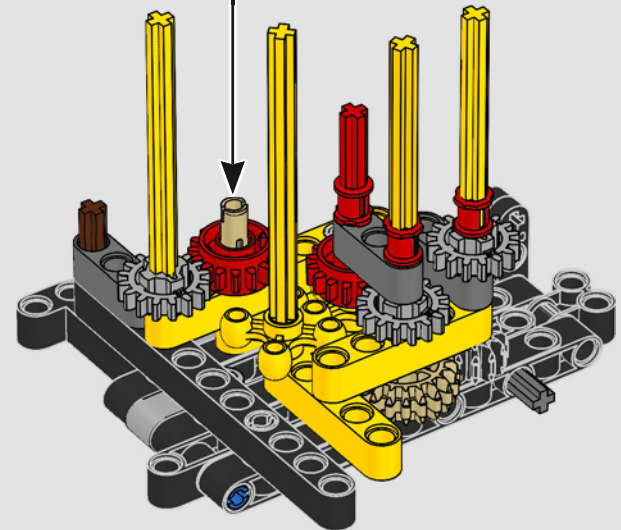
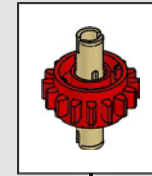

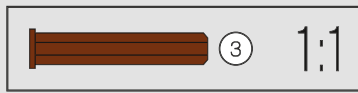
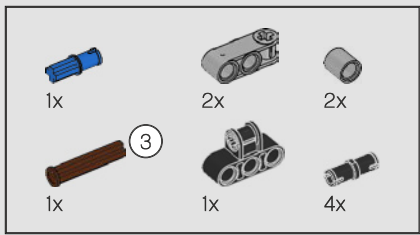

25

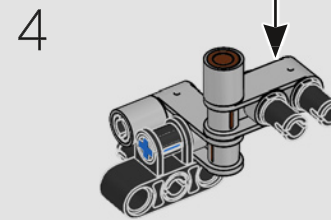
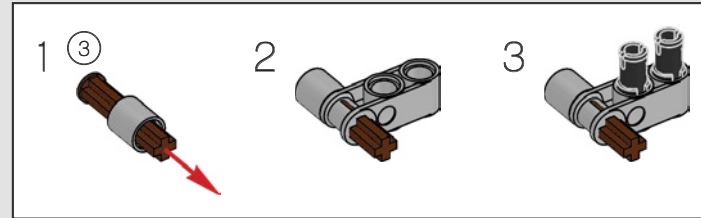
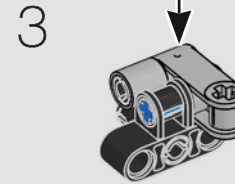
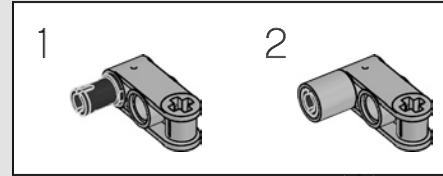
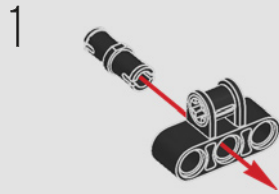

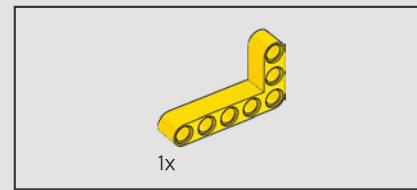
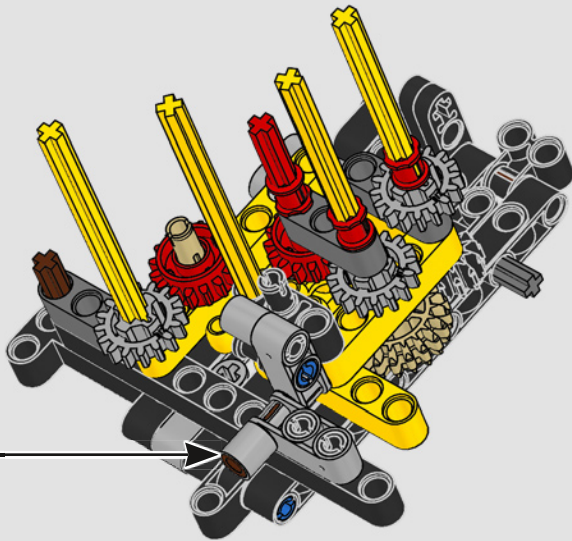

26

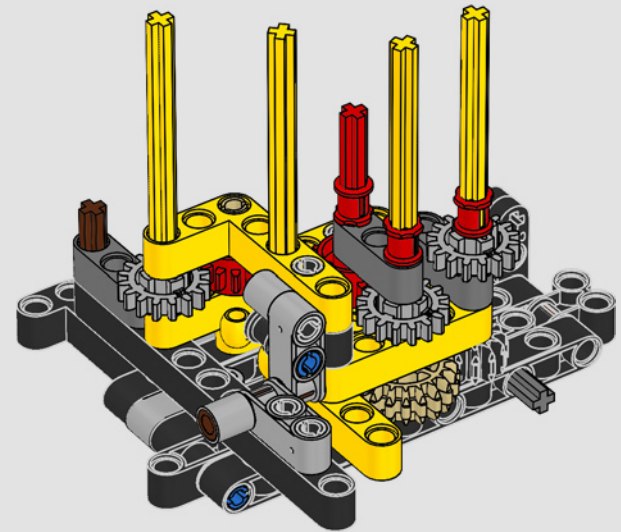

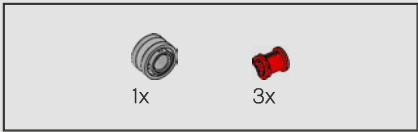

27

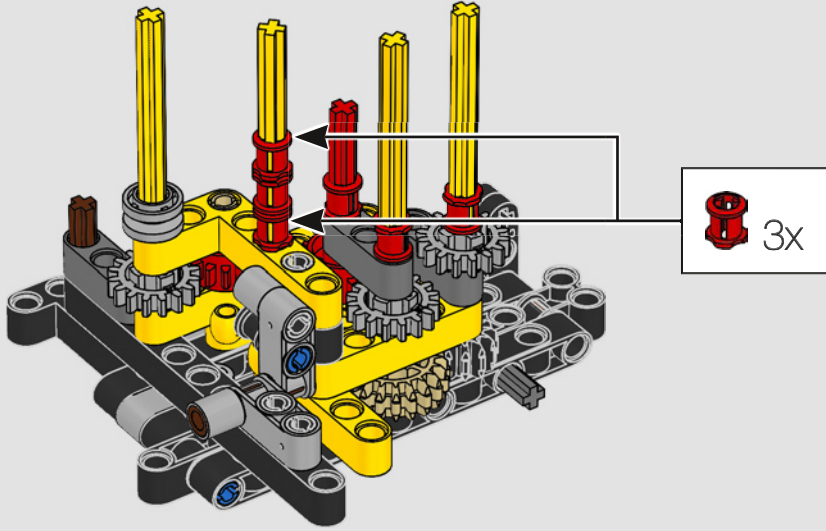

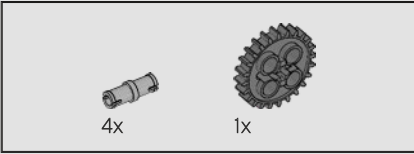
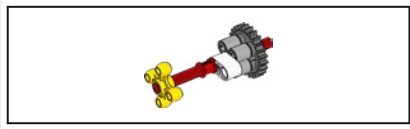

28

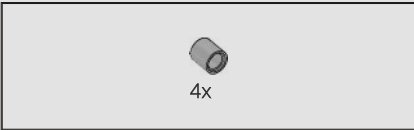
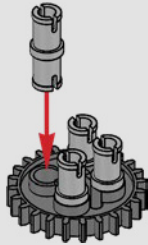

29

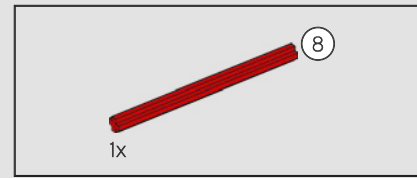
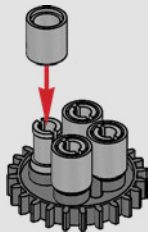

30

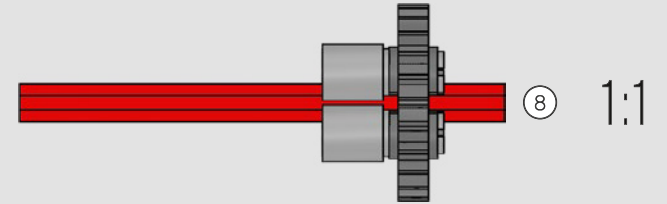

31

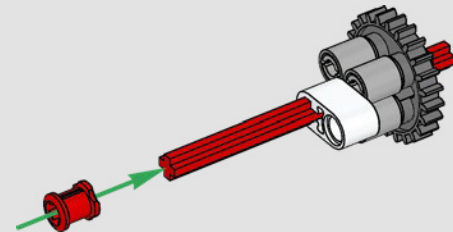



1x

32

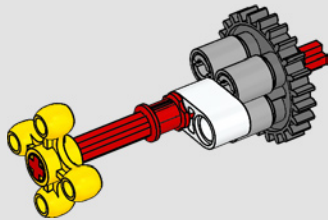

33

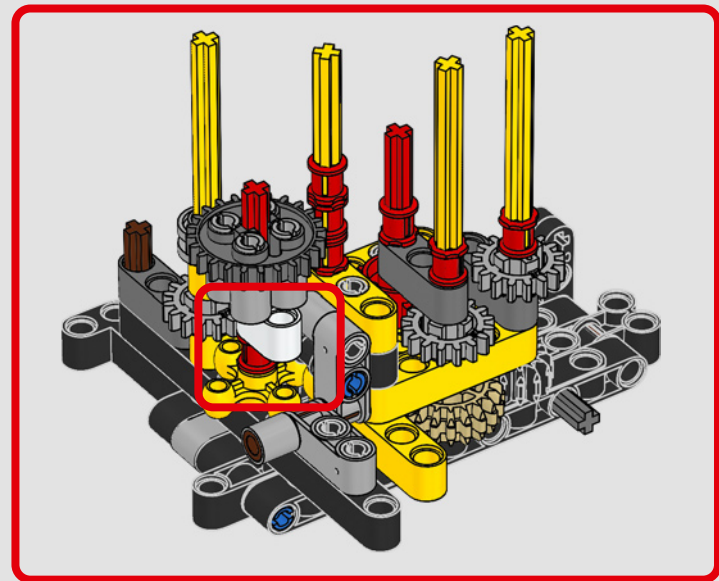
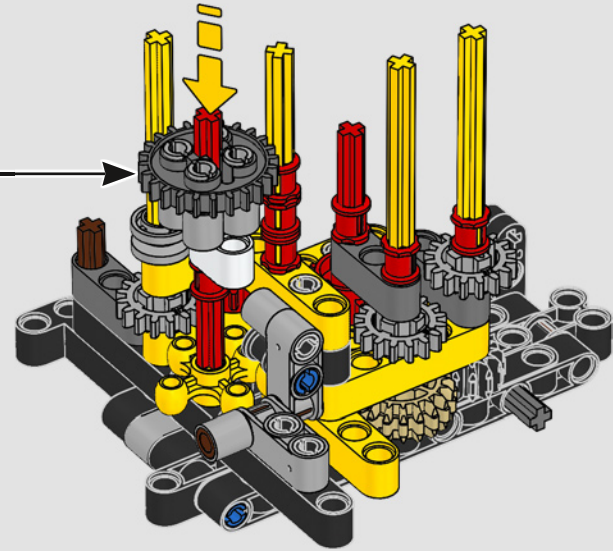

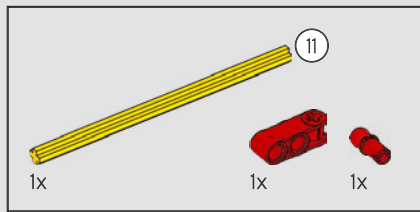

34

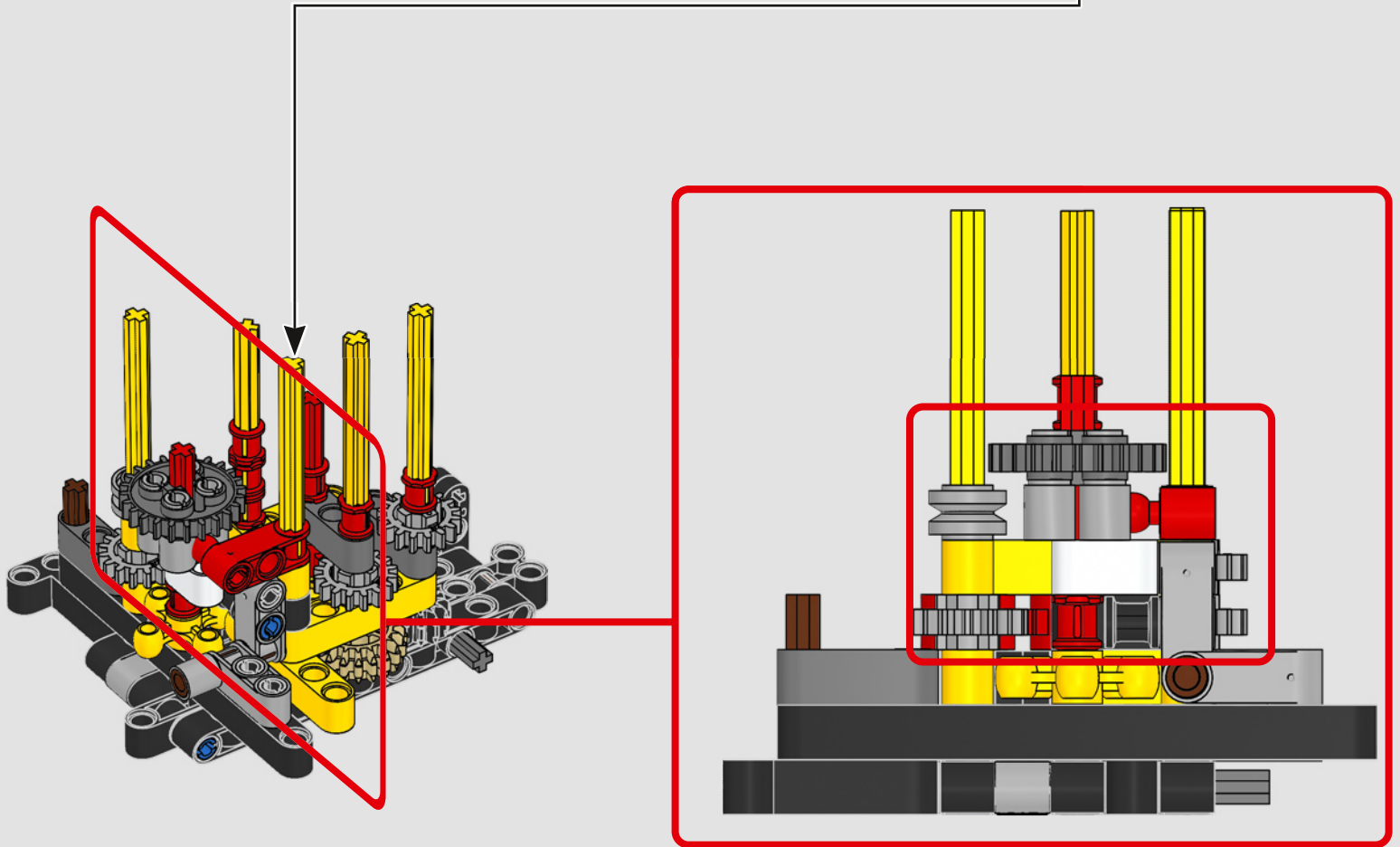
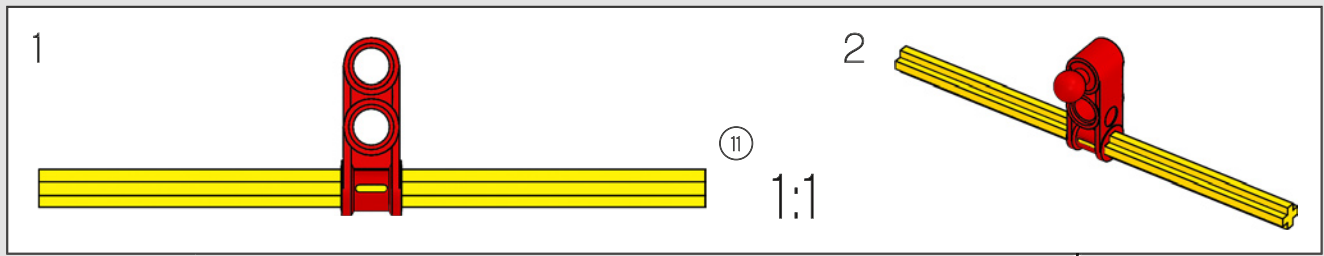

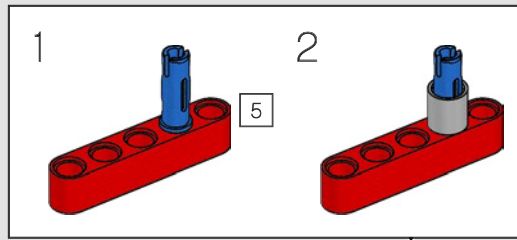
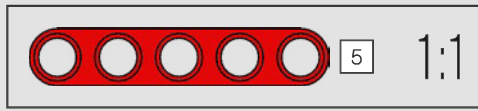
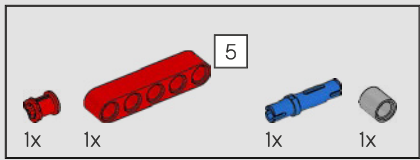

35

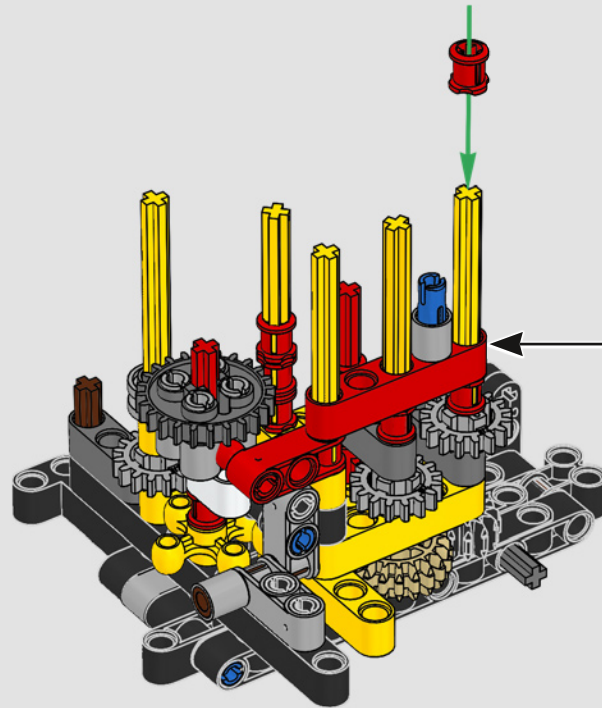

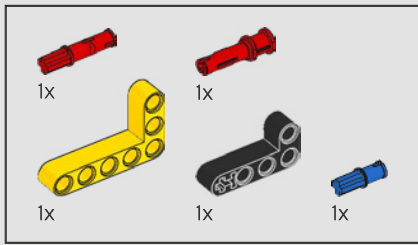

36

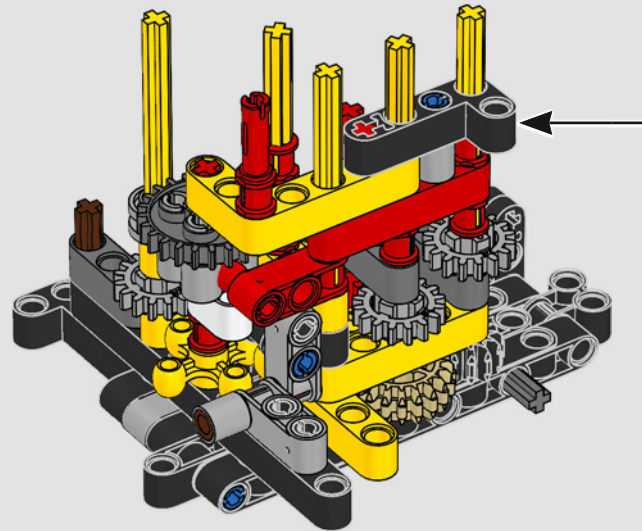
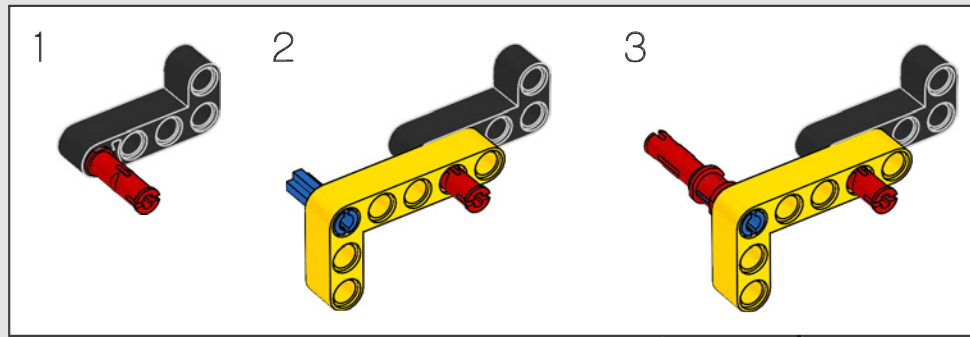

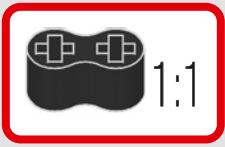
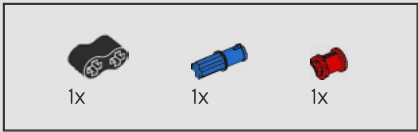

37

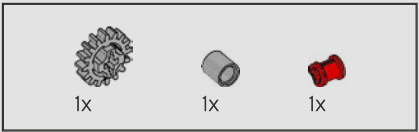
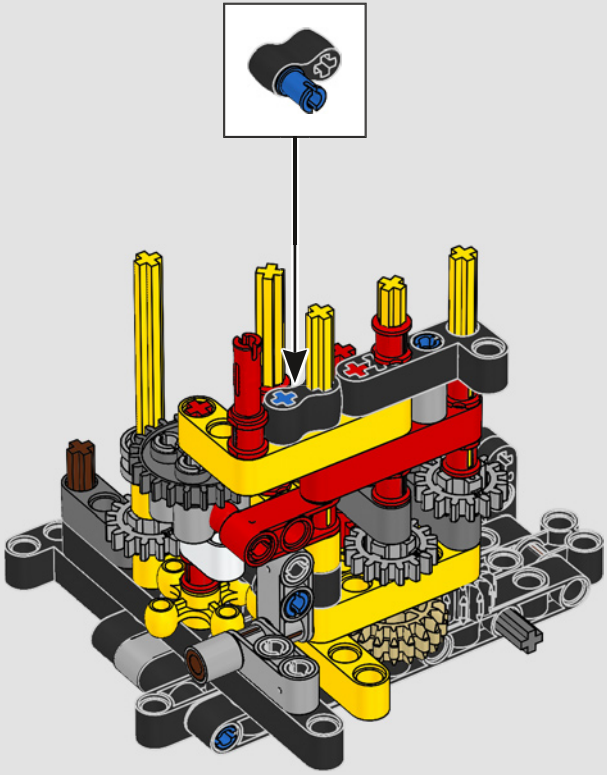

38

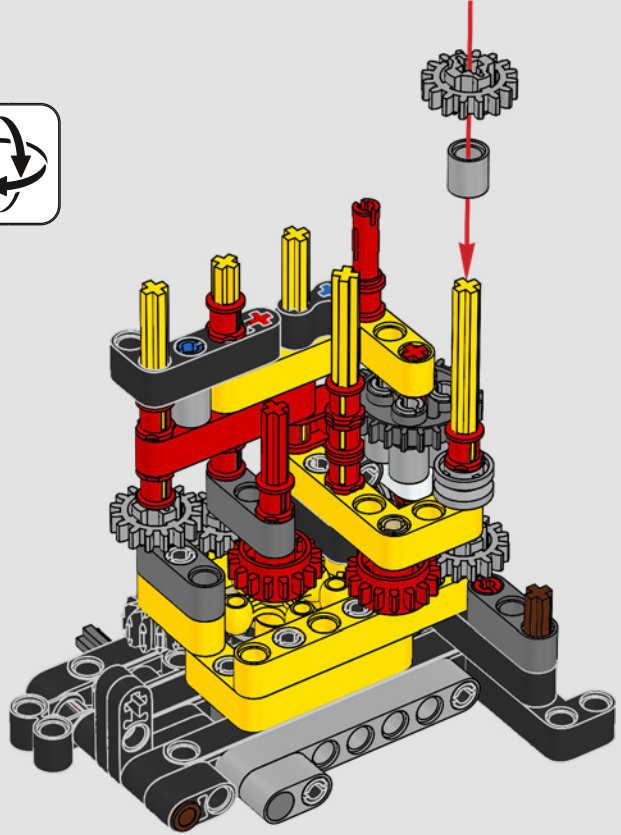

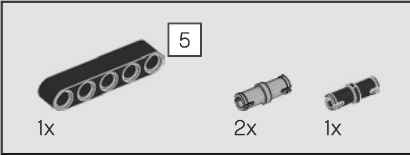
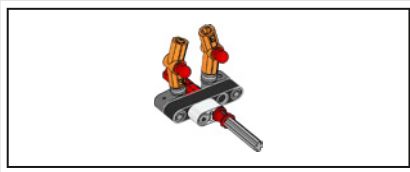

39

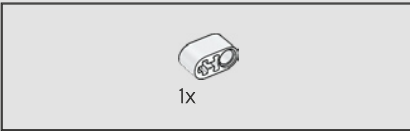
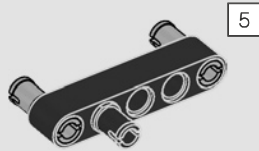

40

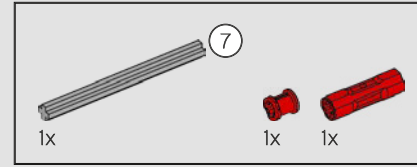
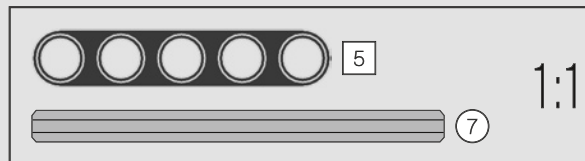

41

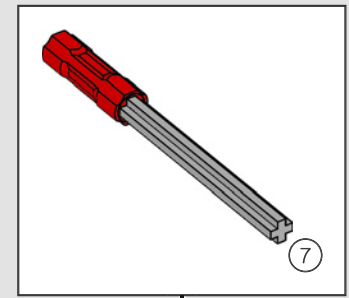

42

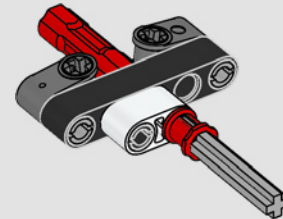
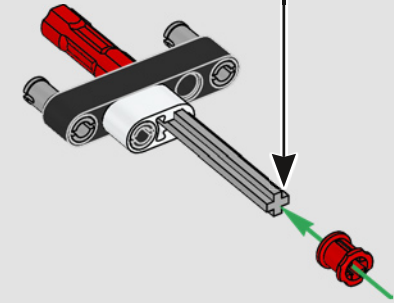

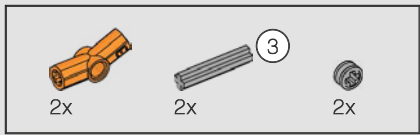

43

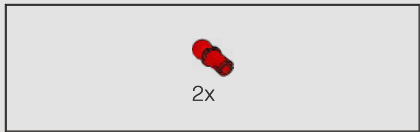
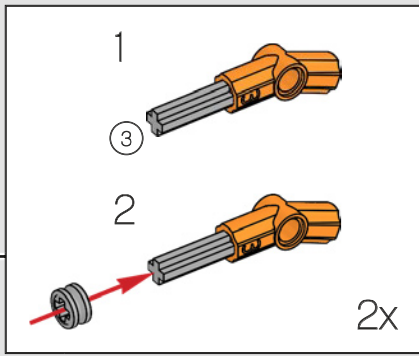
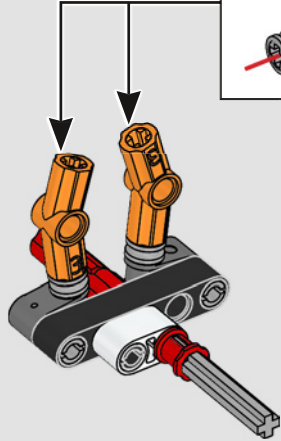

44

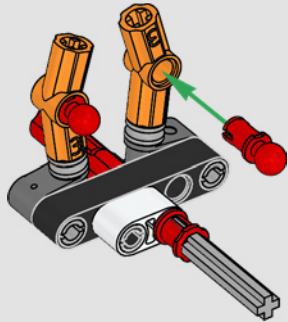

45

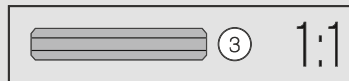
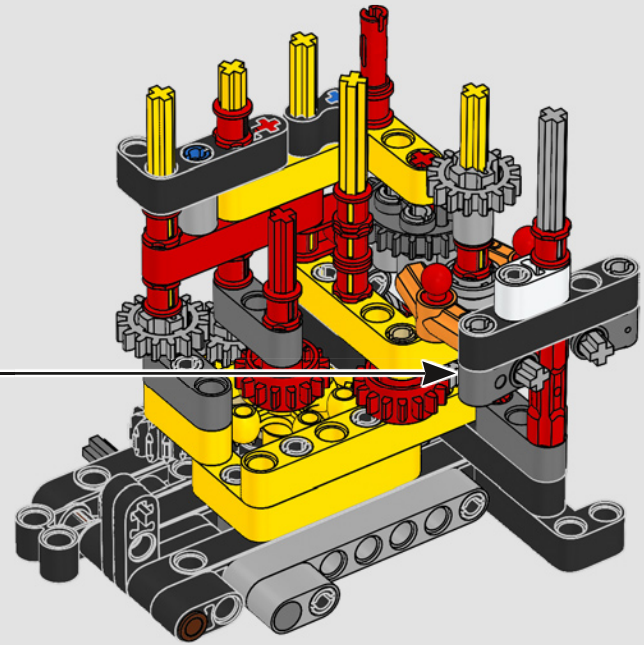



46

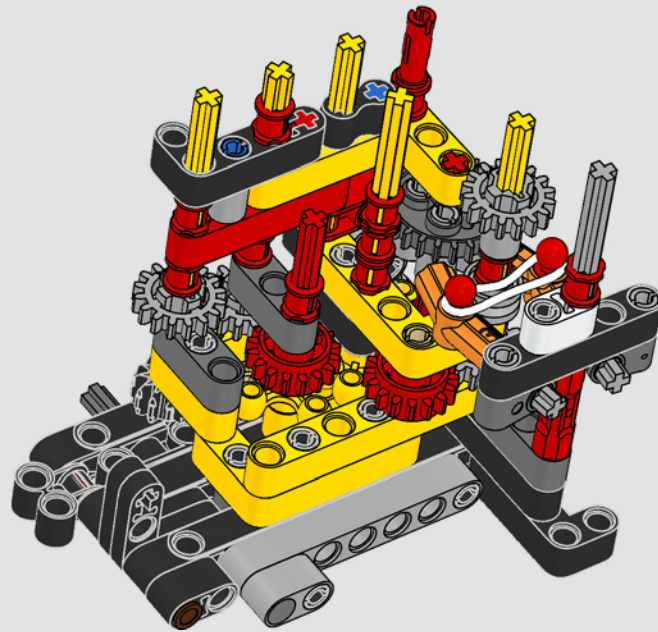

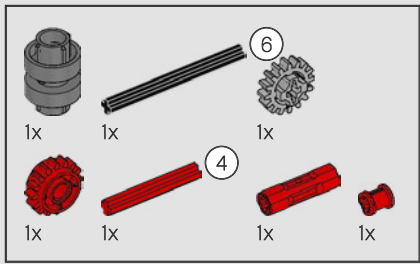

47

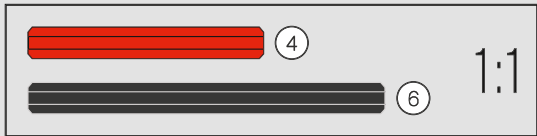
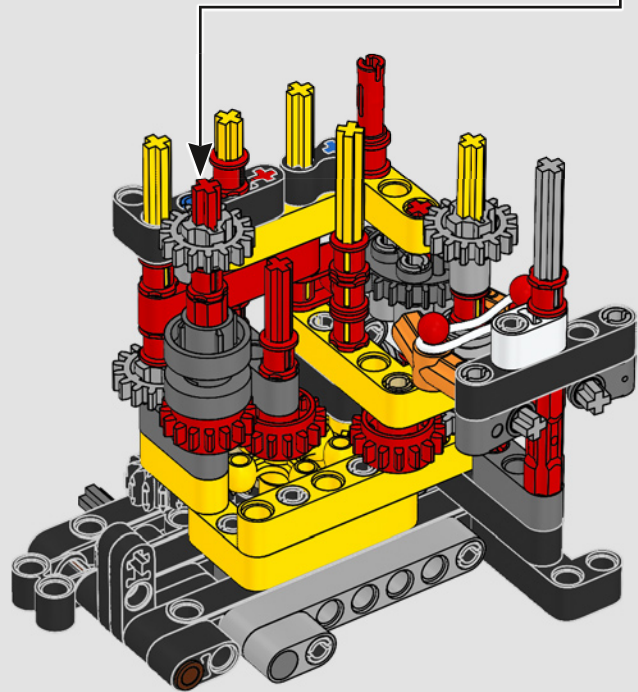
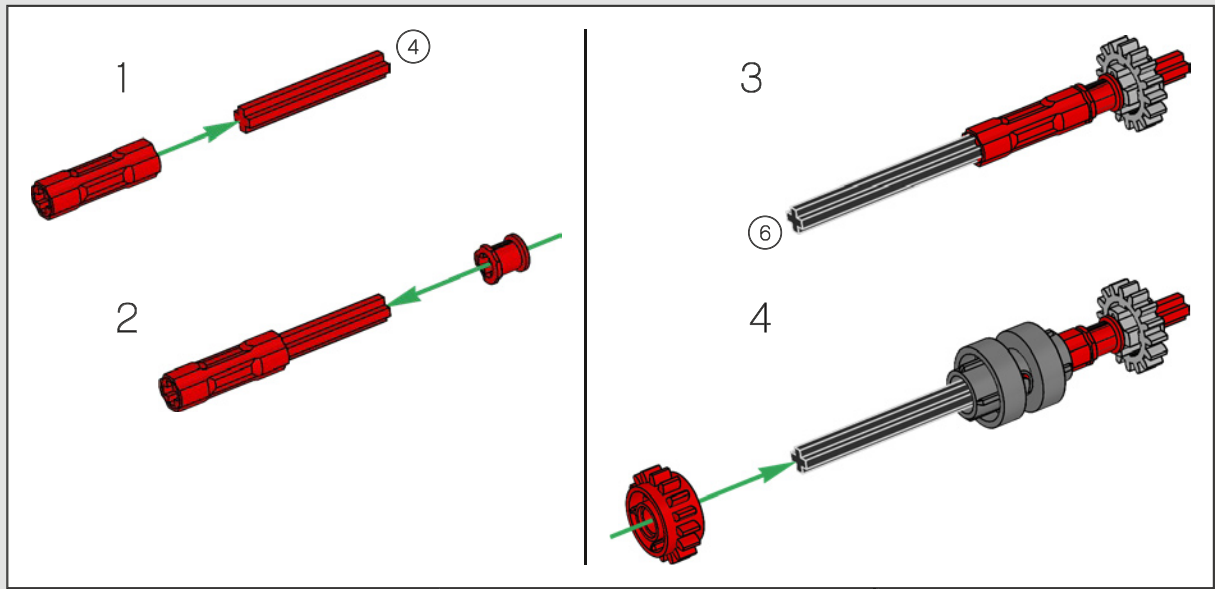



48

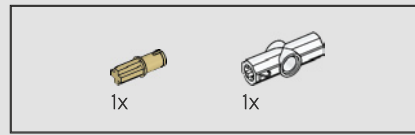
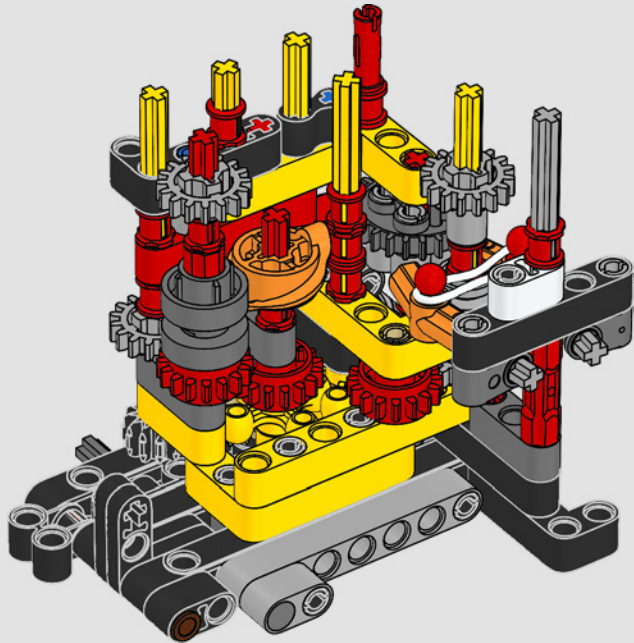
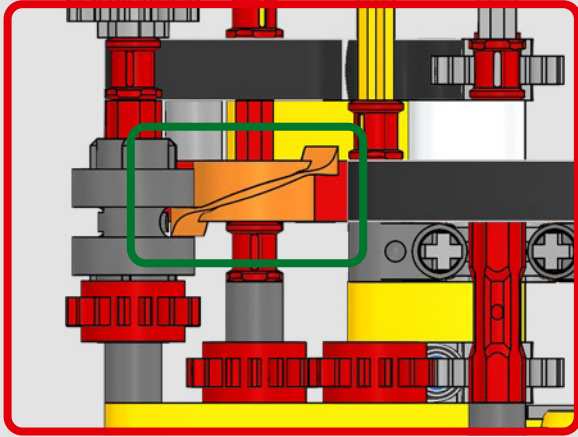

49

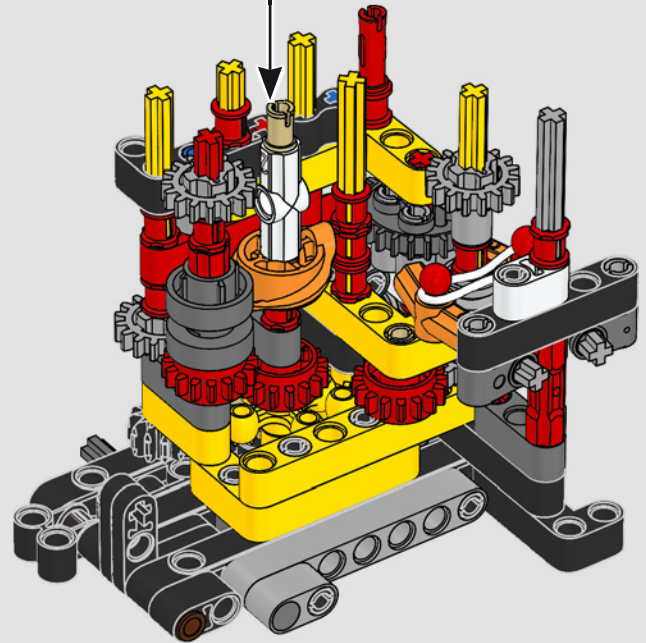
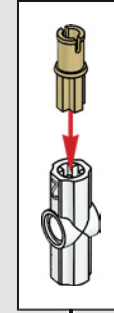



50

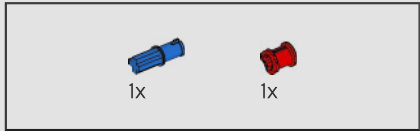
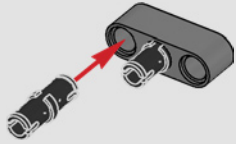

51

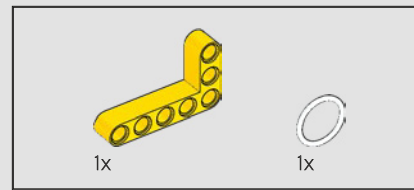
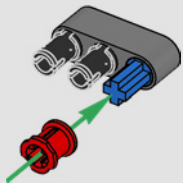

52

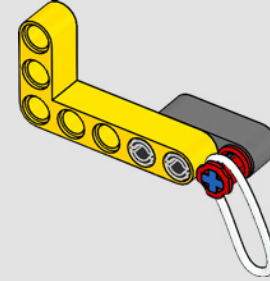

53

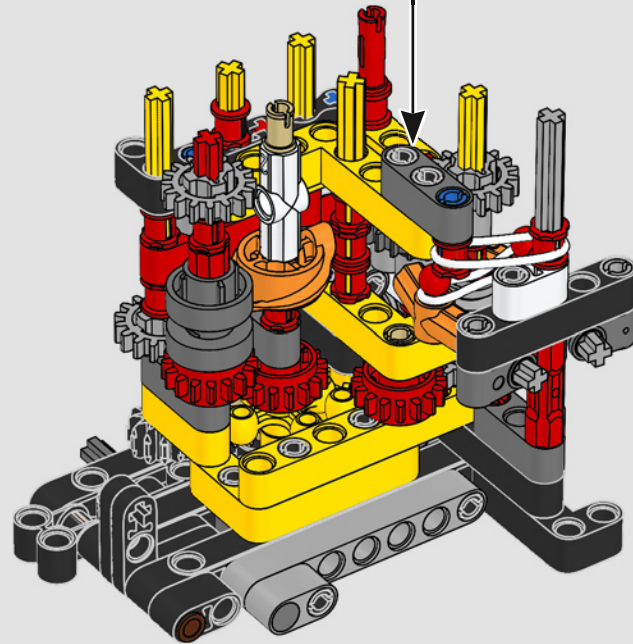

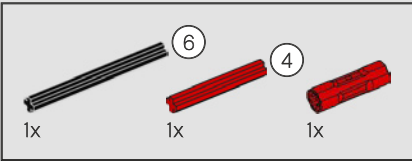
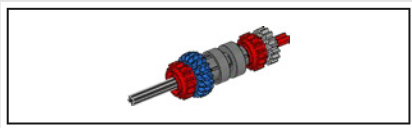

54

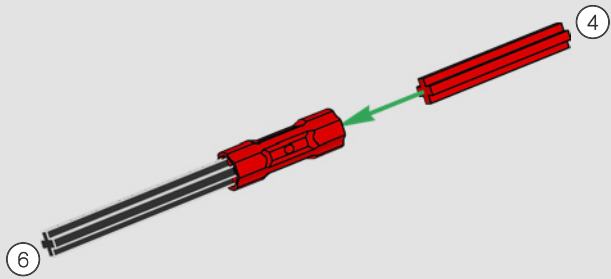

55

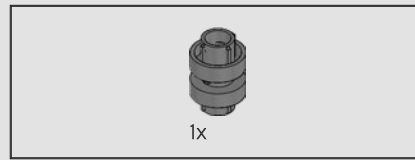
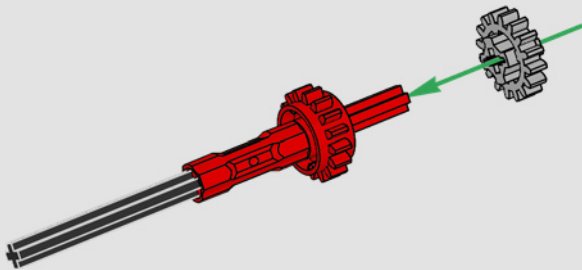

56

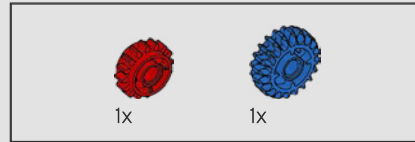
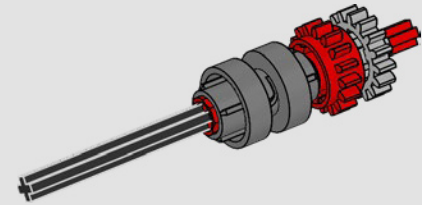

57

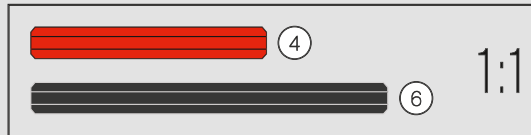
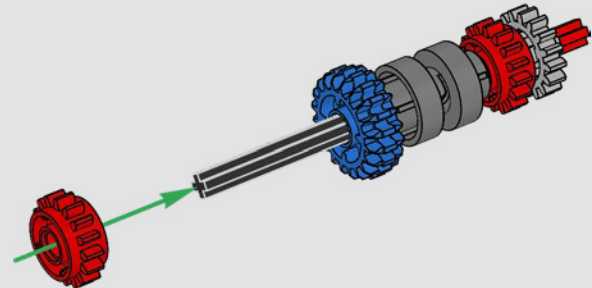

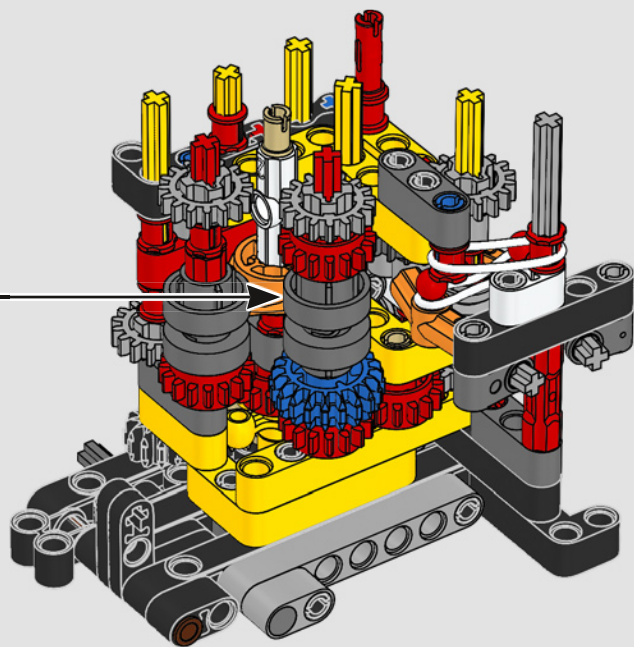

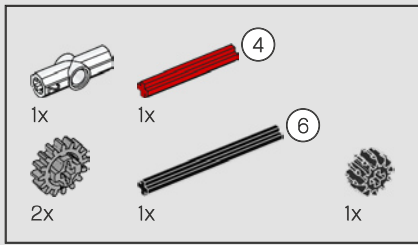

59

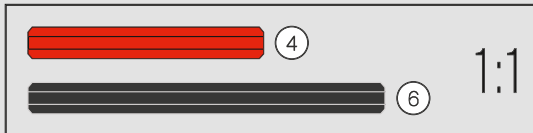
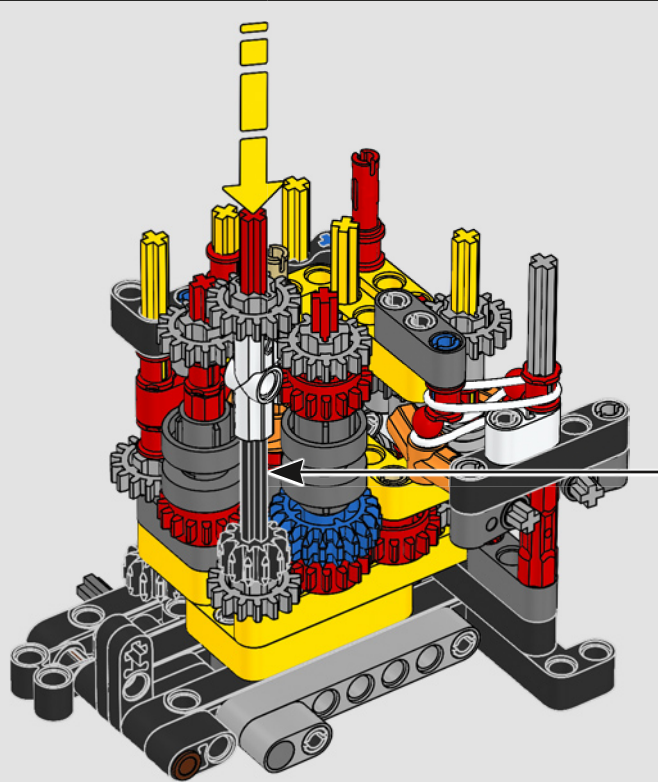
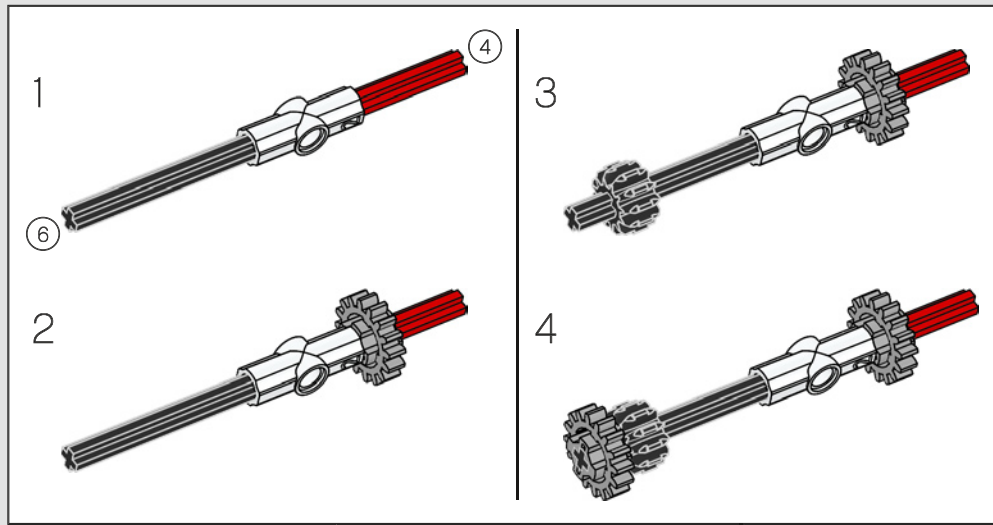

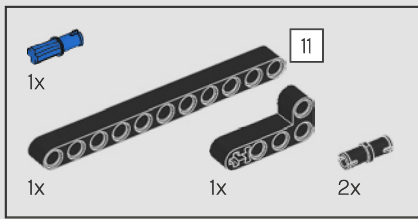

60

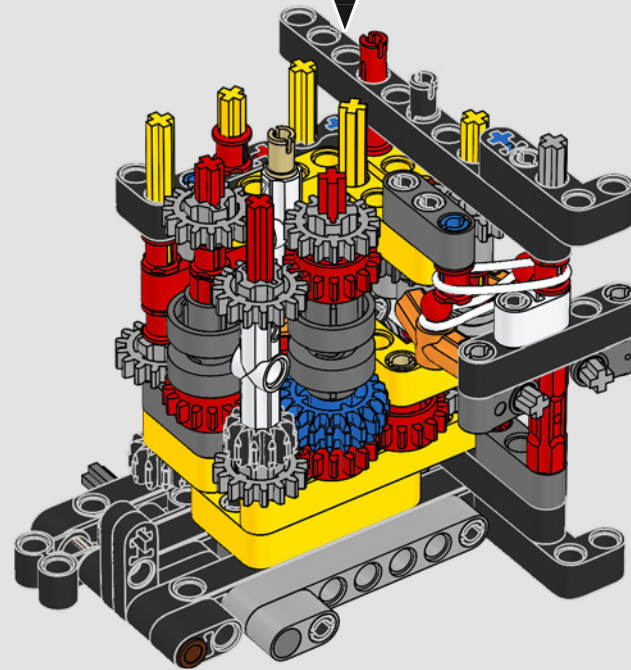
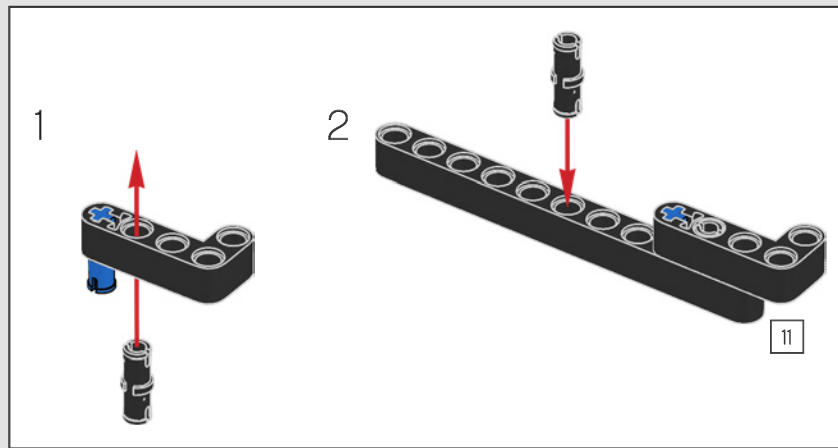

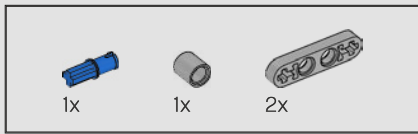

61

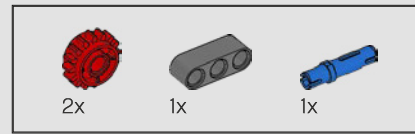
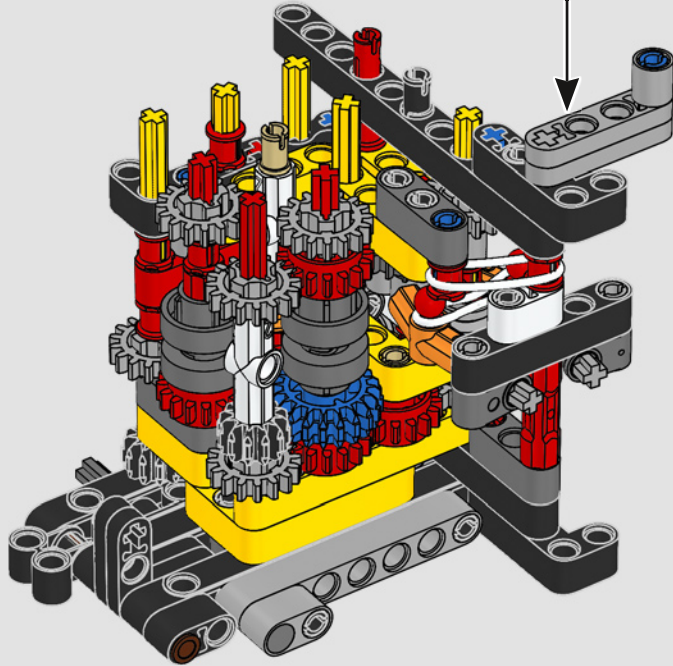
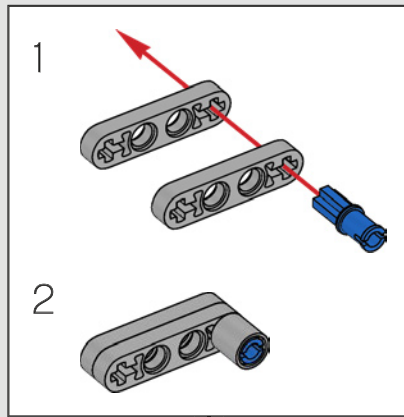

62

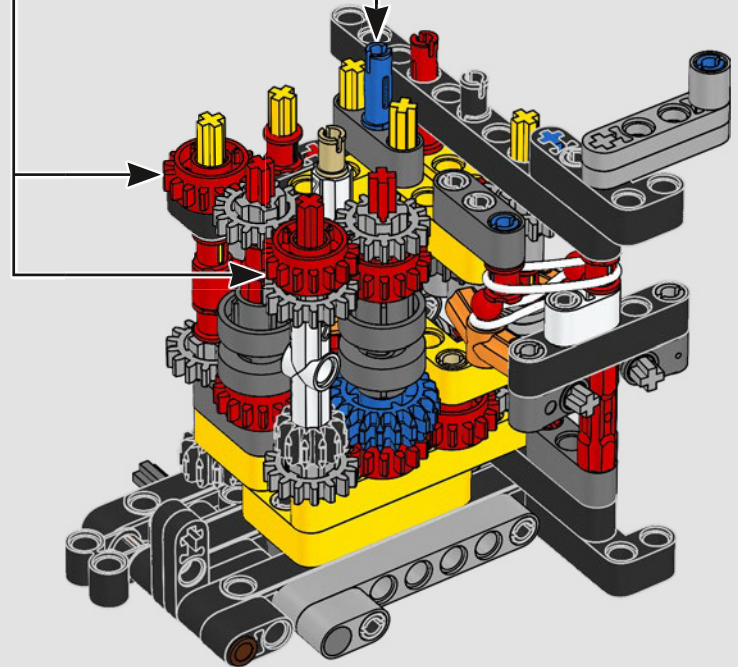
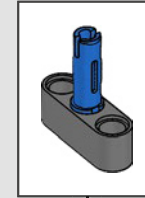
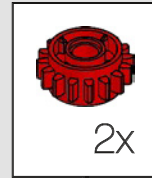

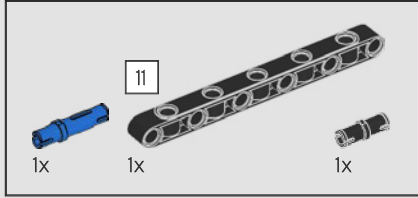
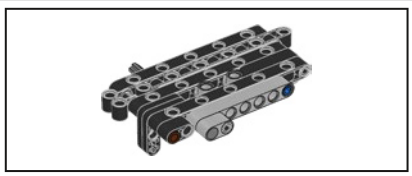

63

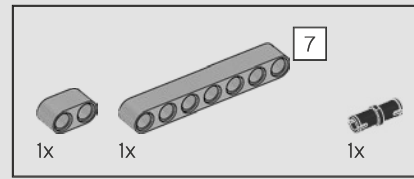
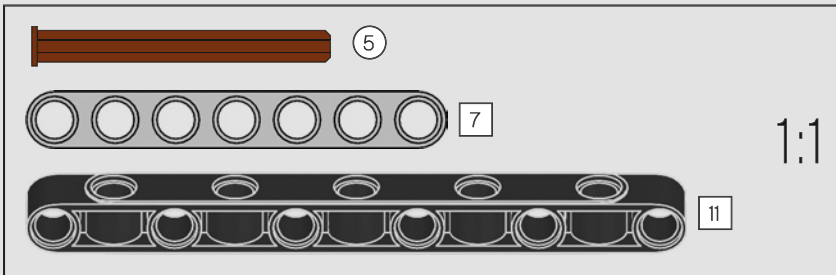
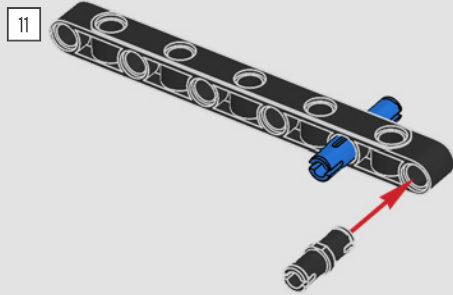

64

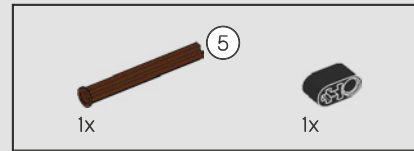
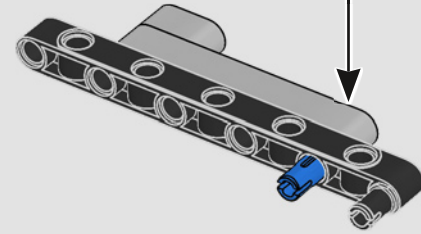
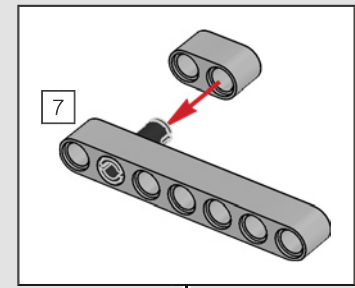

65

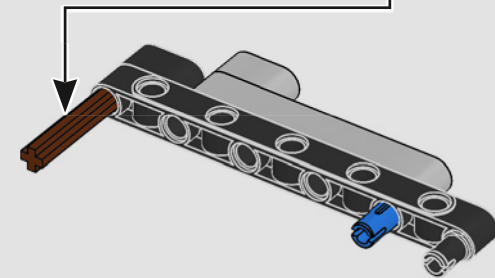
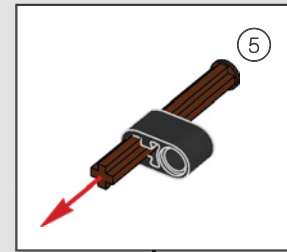



66

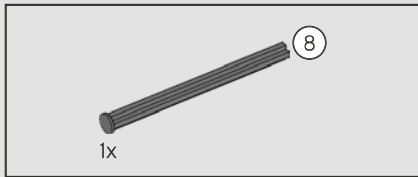
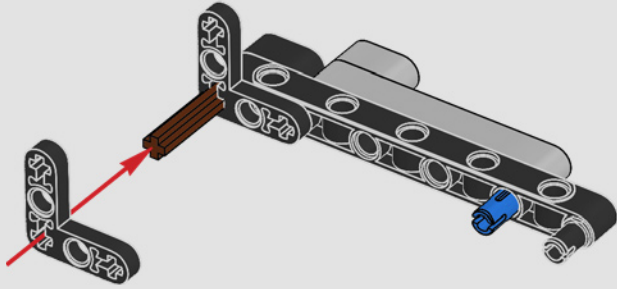

67

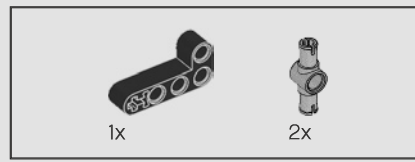
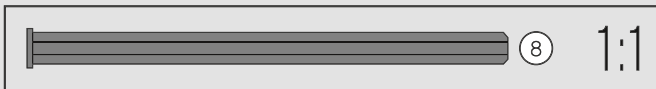
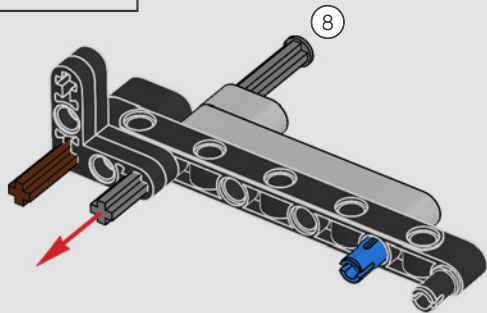

68

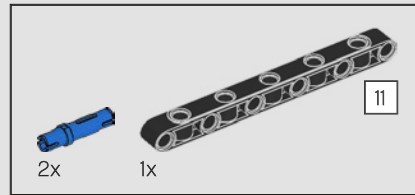
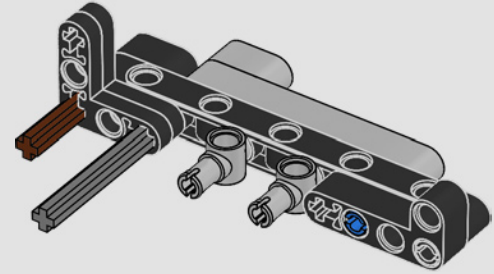

69

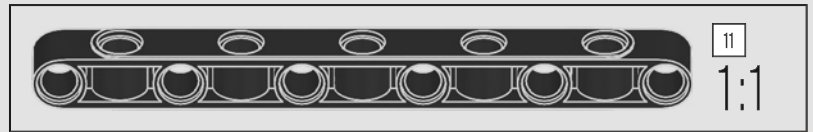
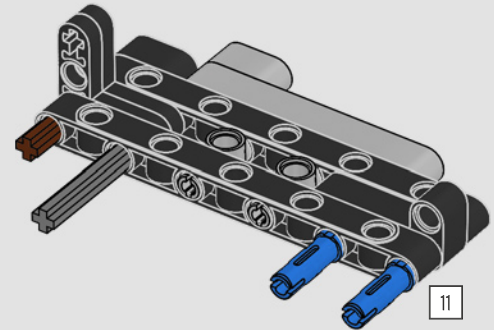

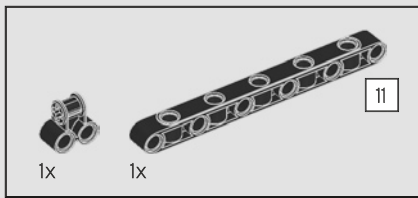

70

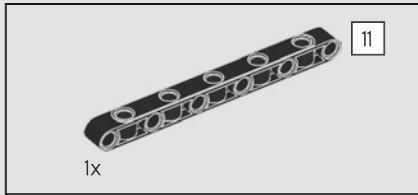
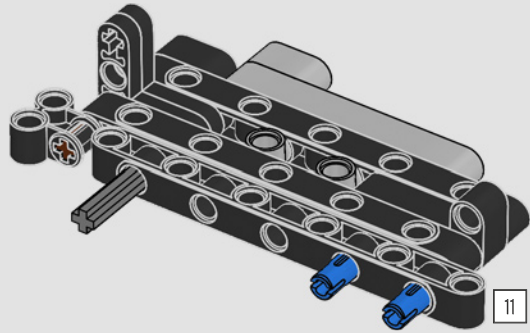

71

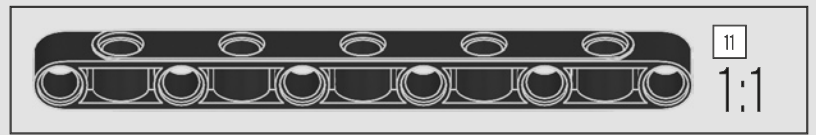
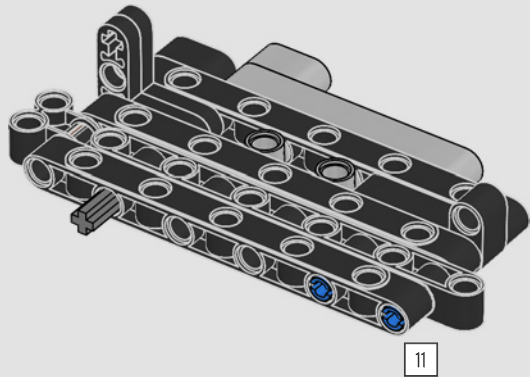

72

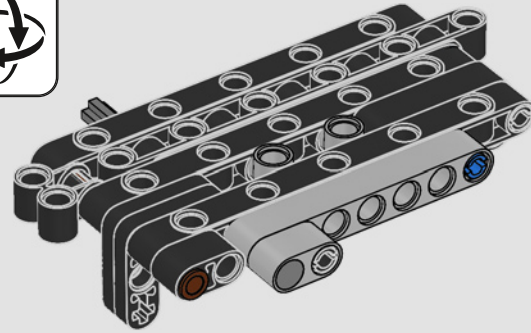

73

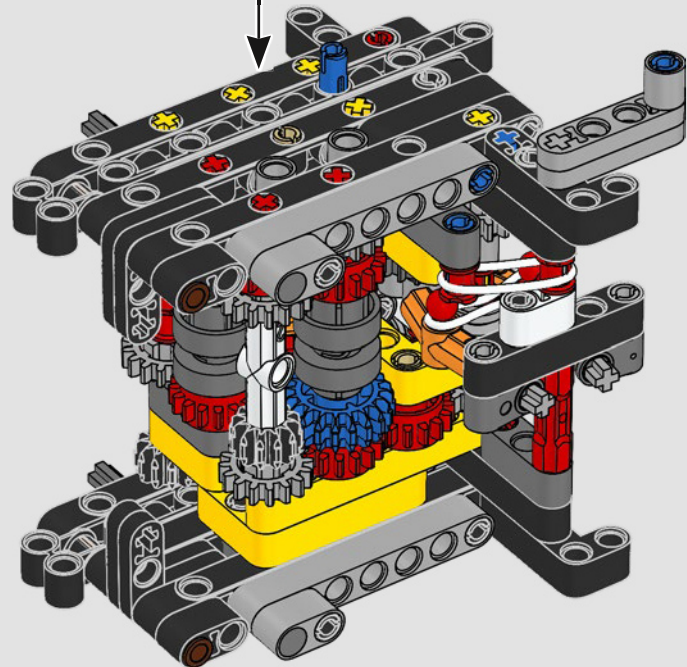

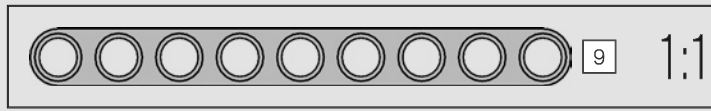
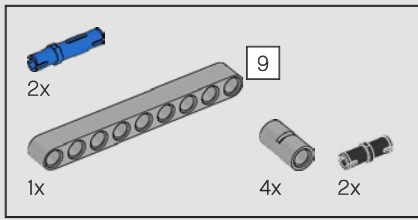

74

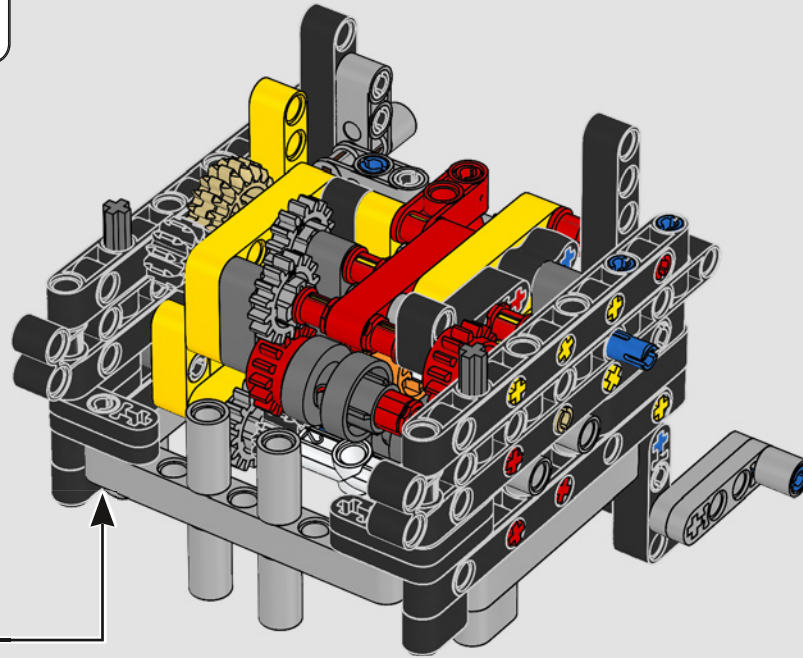
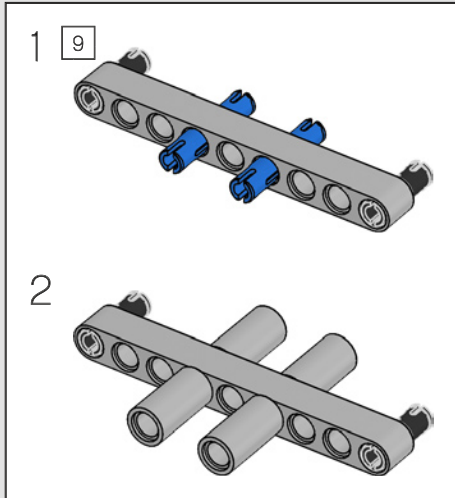

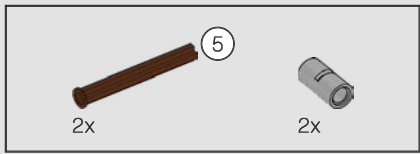

75

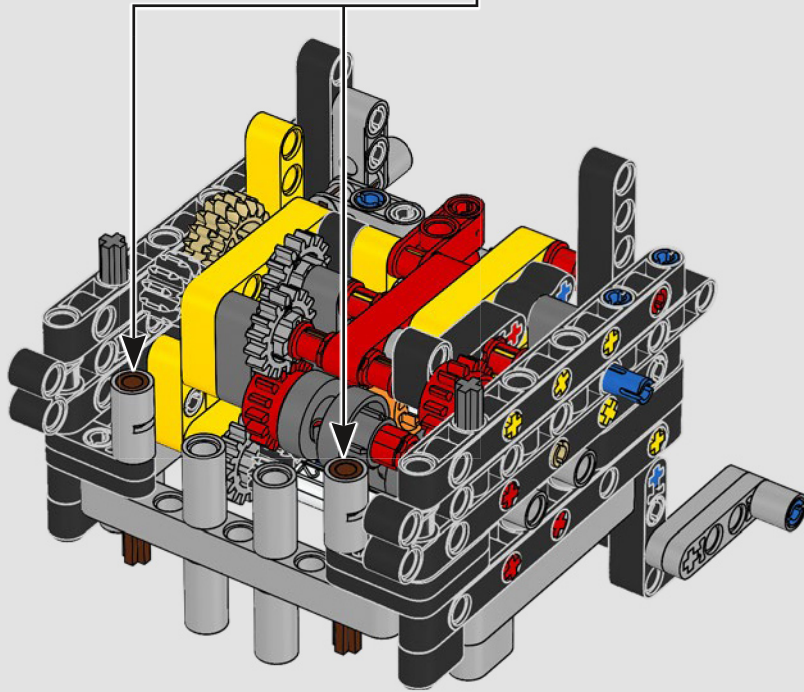
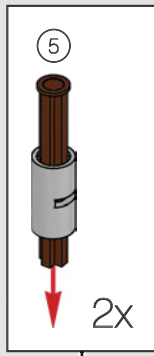

76

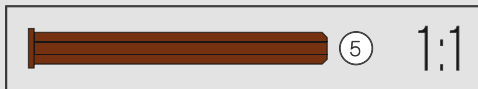
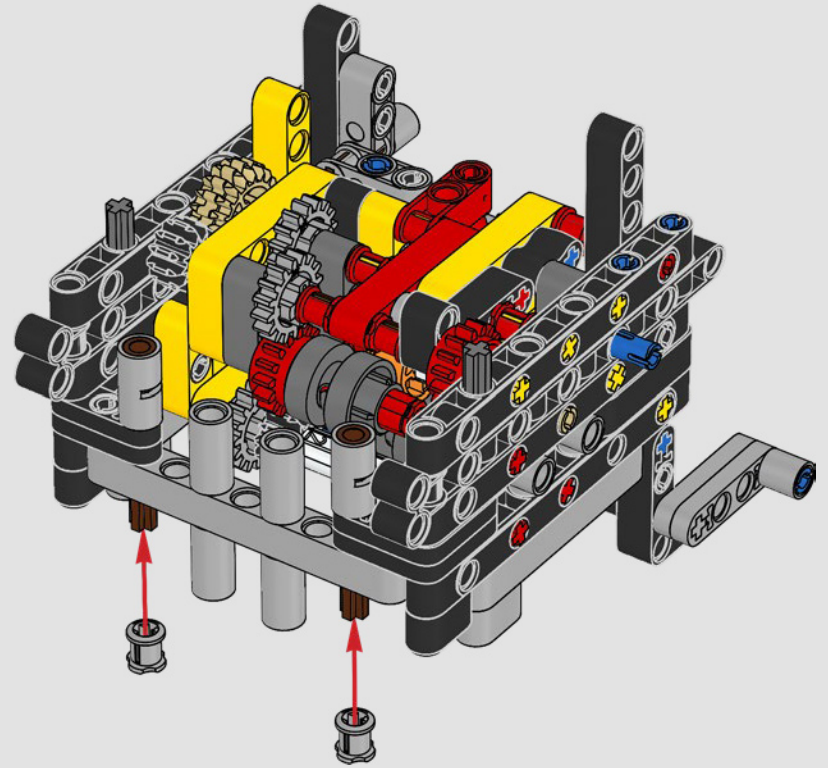

62x

77

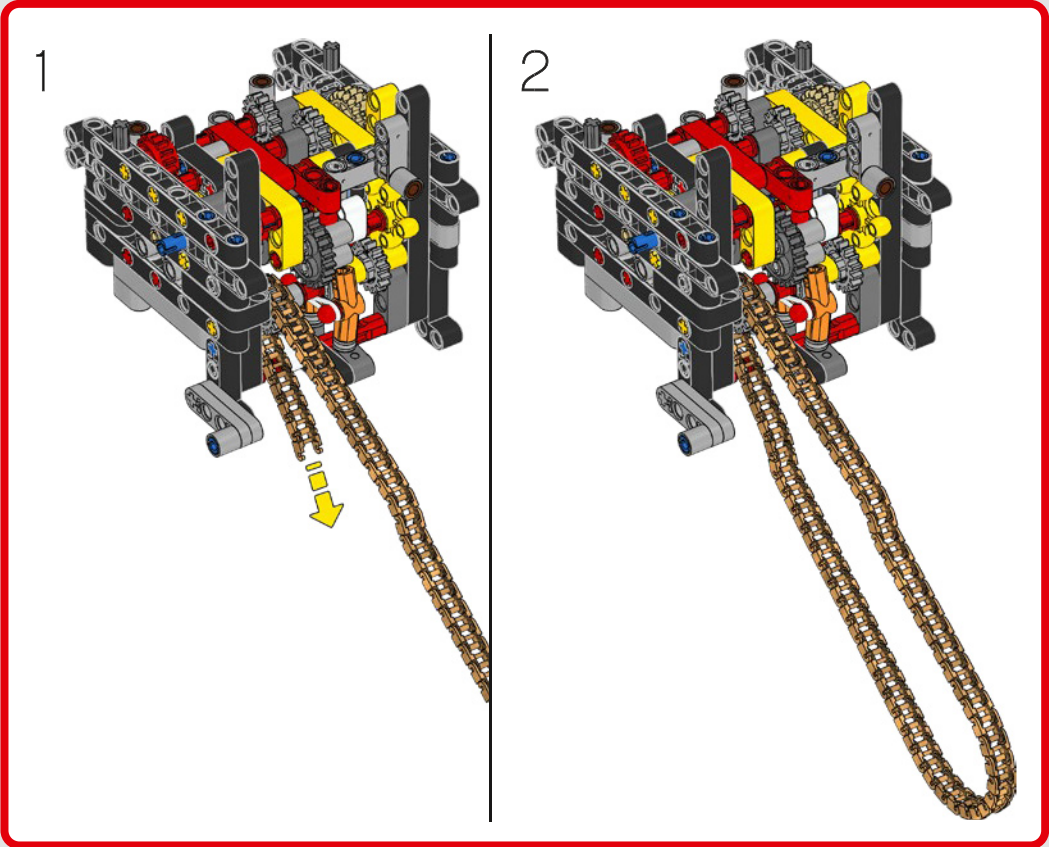
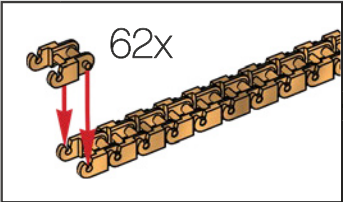
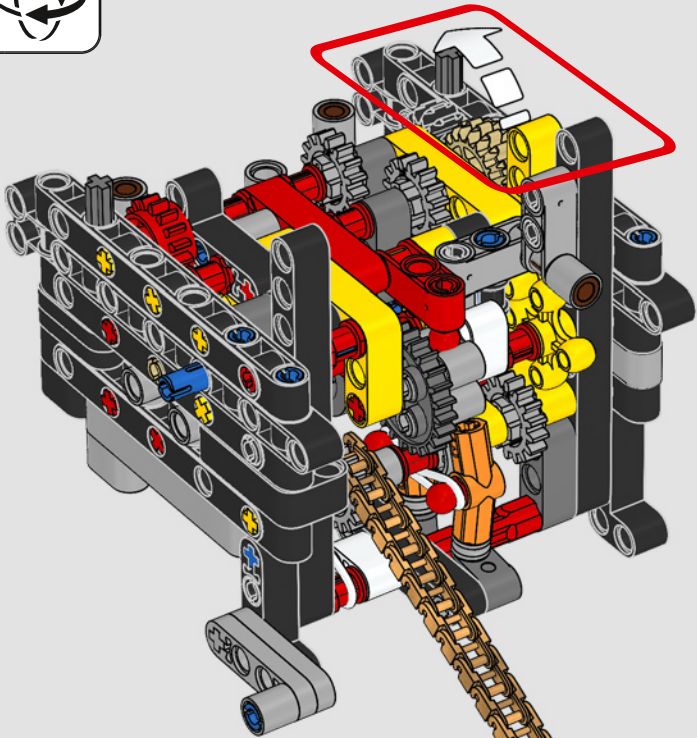

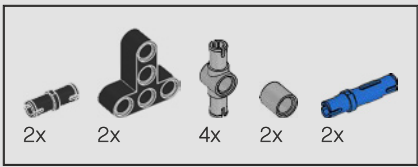

78

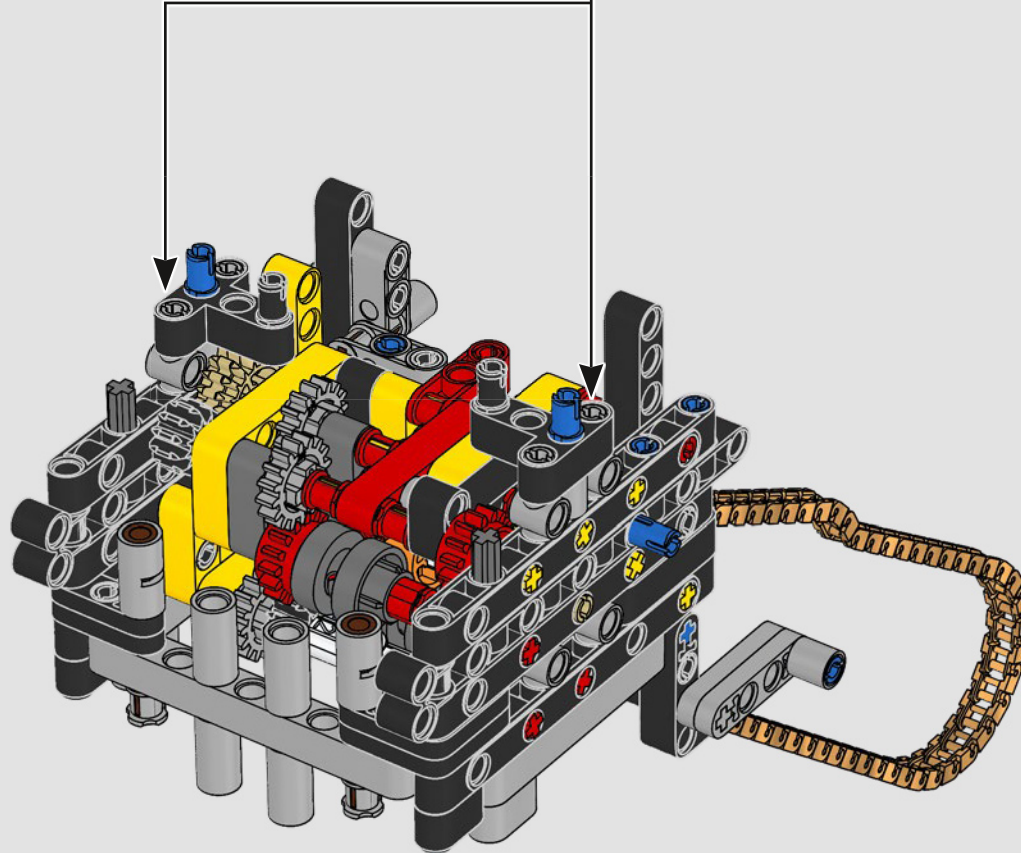
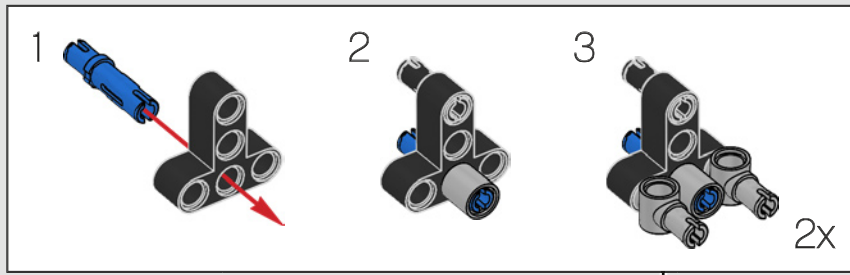

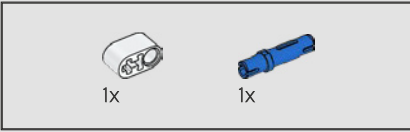
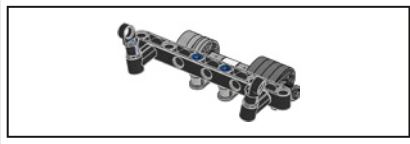

79

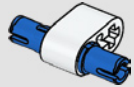

80

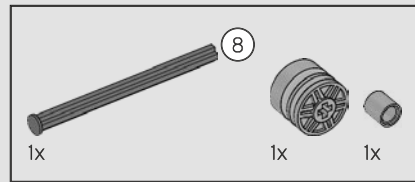
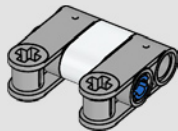

81

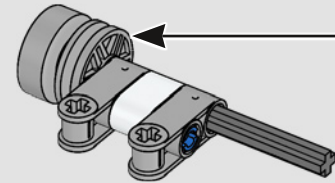
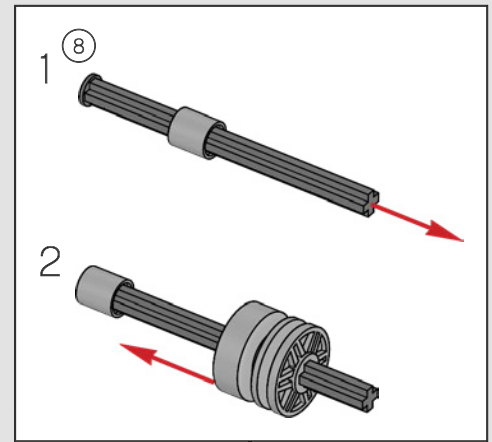

82

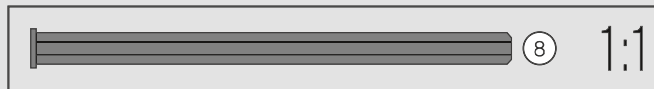
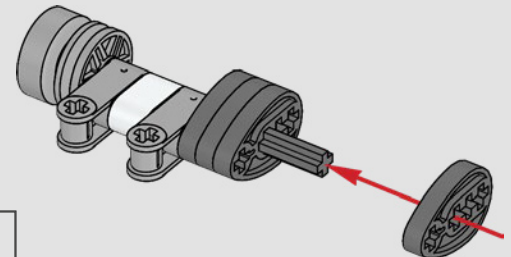

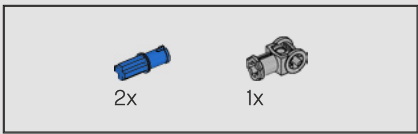

83

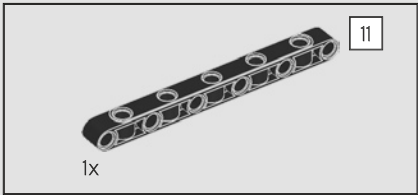
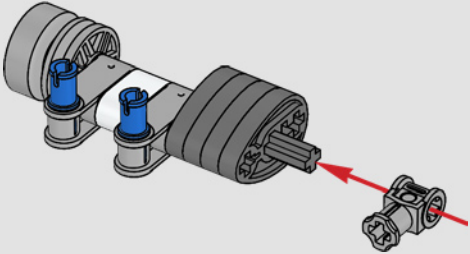

84

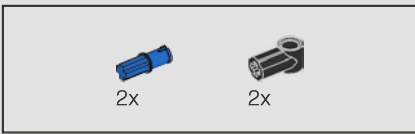
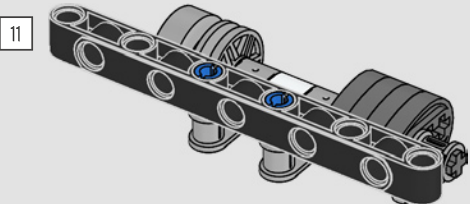

85

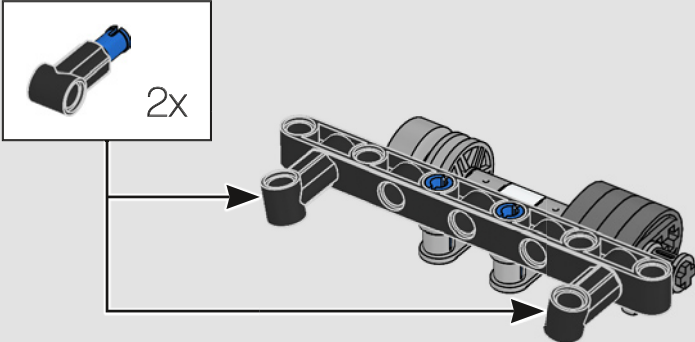

86

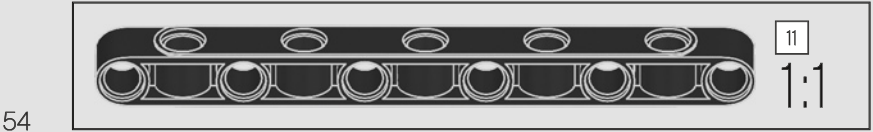
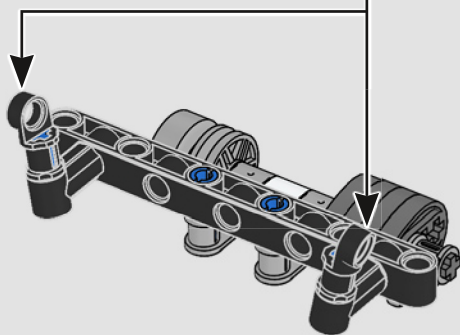
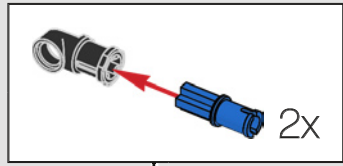

87

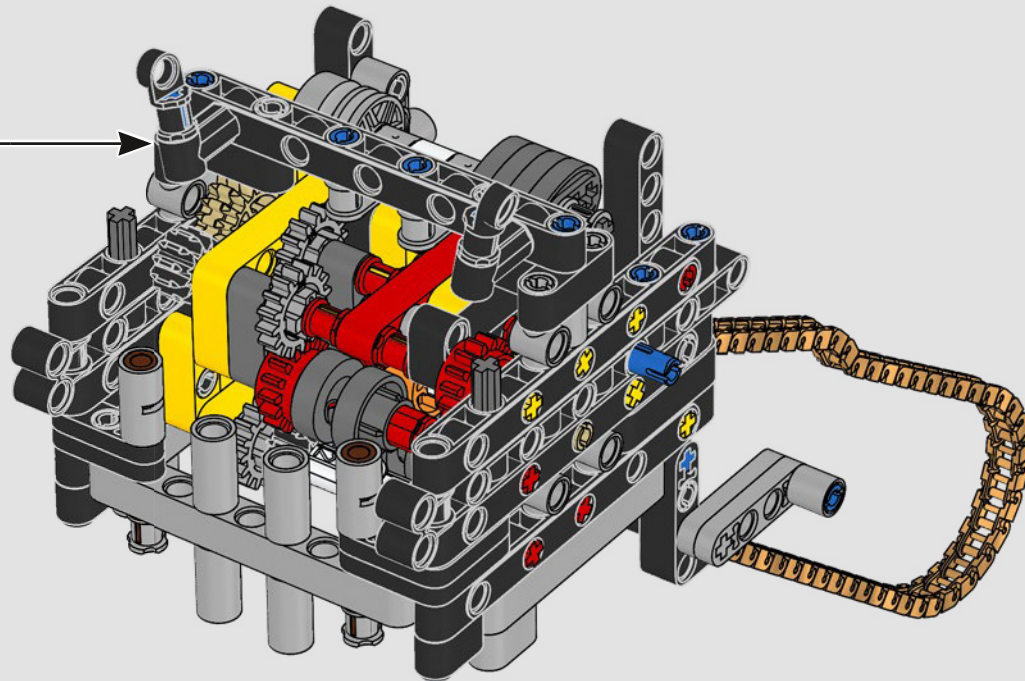

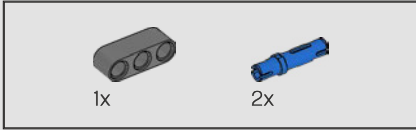
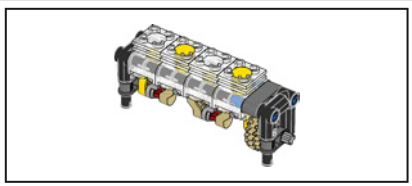

88

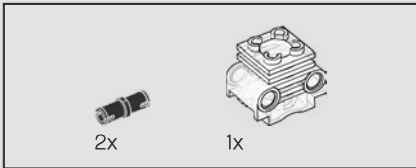
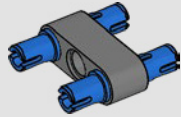

89

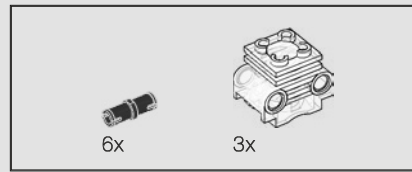
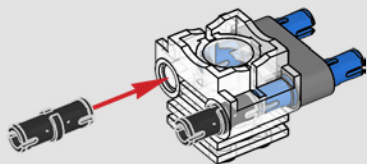

90

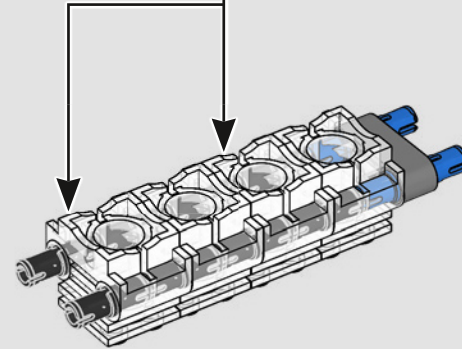
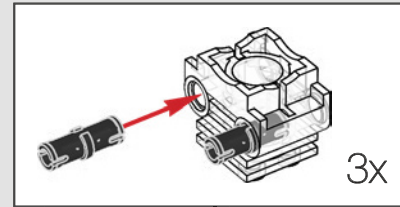

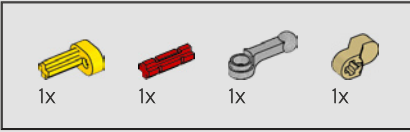
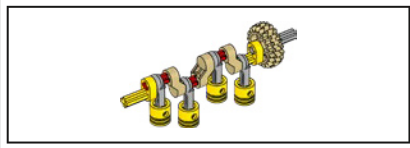

91

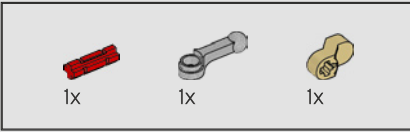
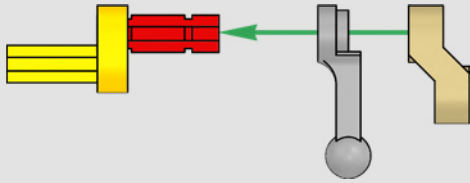

92

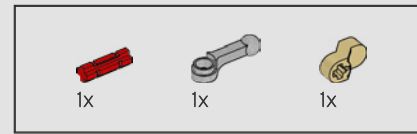
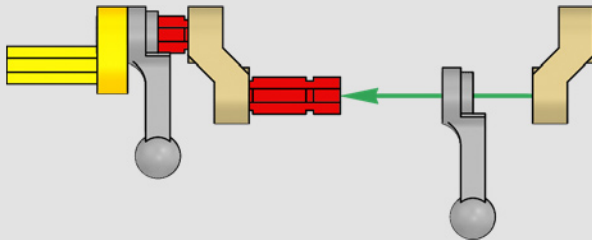

93

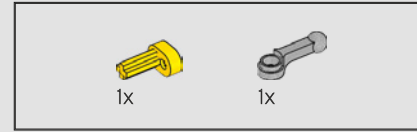
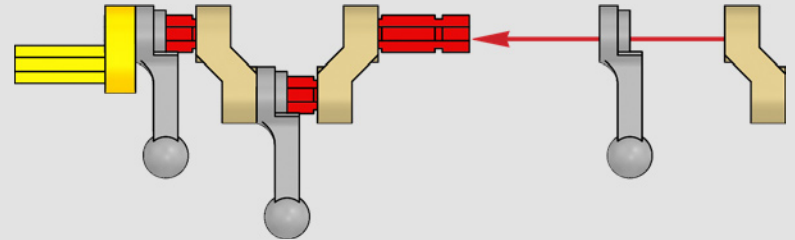

94

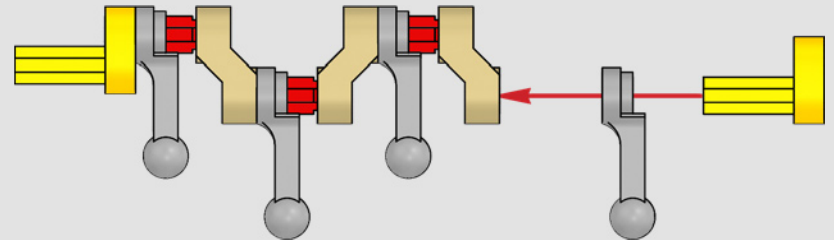



4x

95

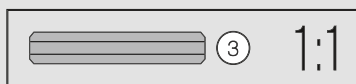
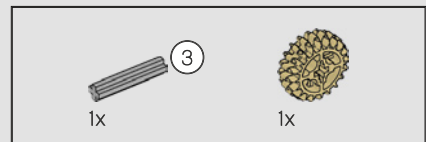
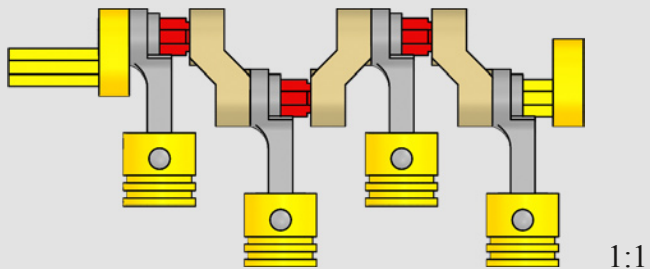

96

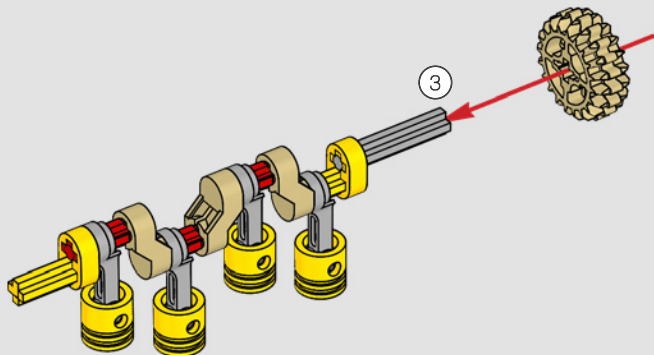

97

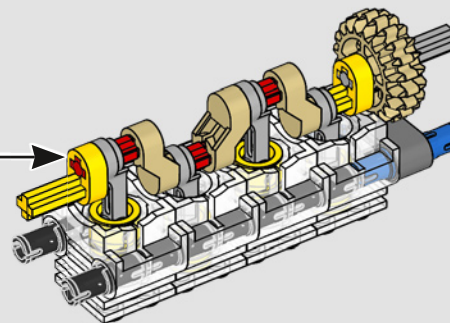

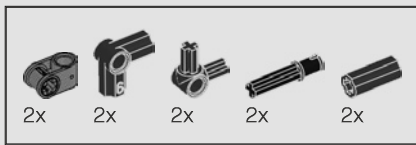

98

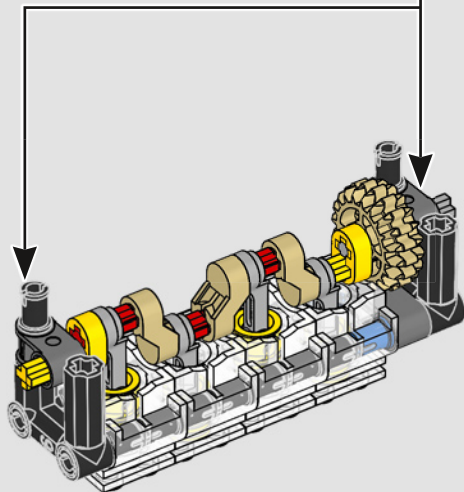
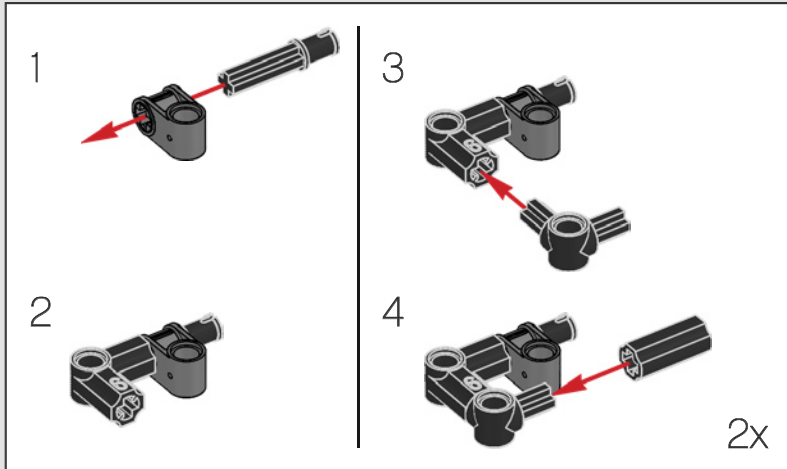

99

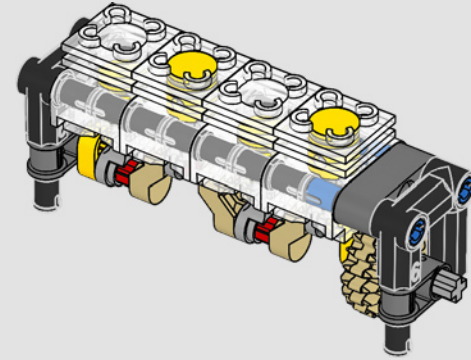
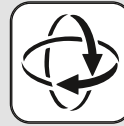

100

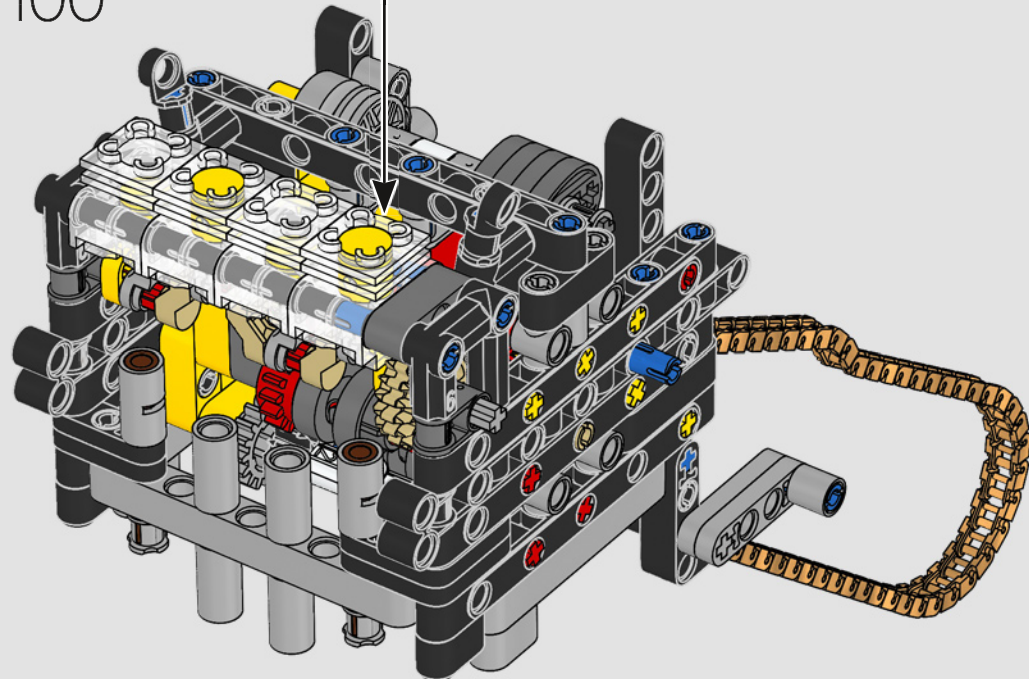

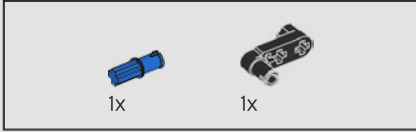
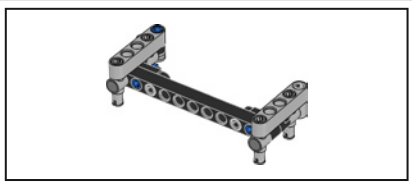

101

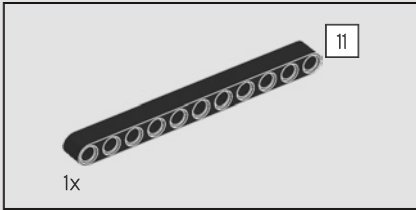

102

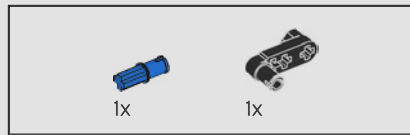
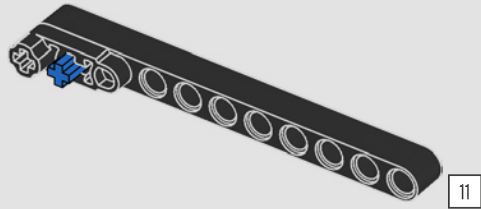

103

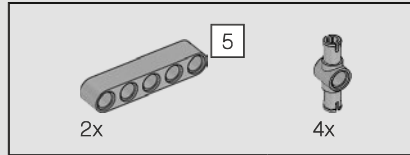
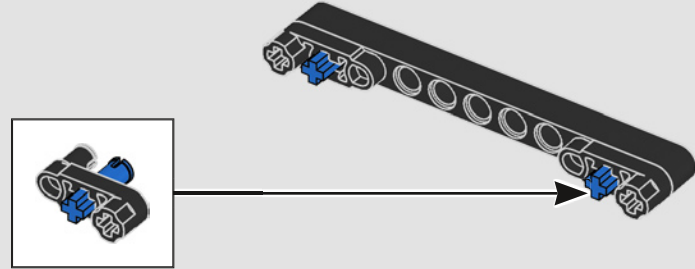

104

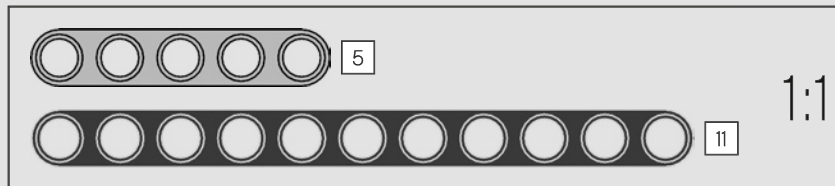
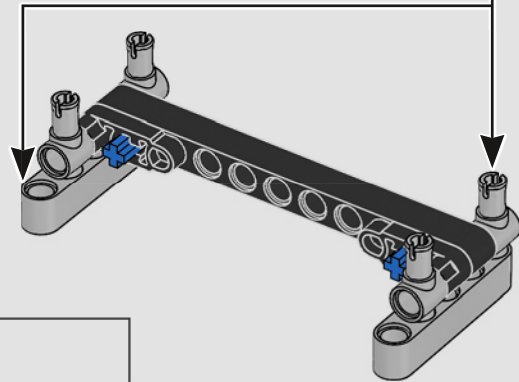
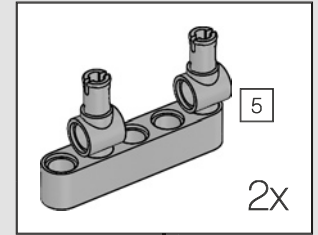

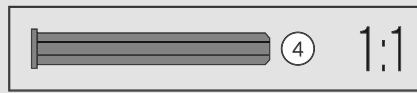
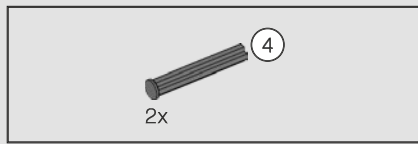

105

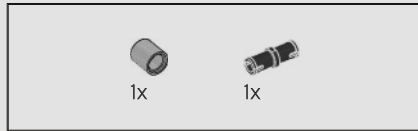
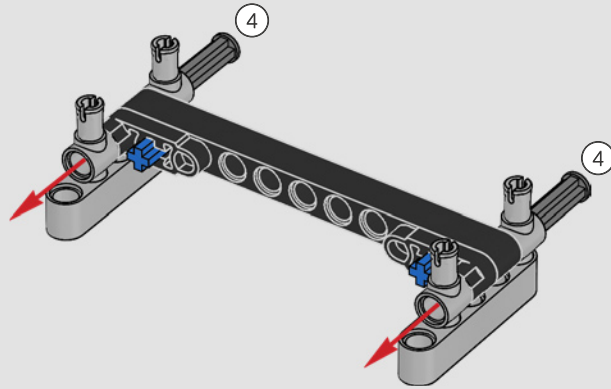

106

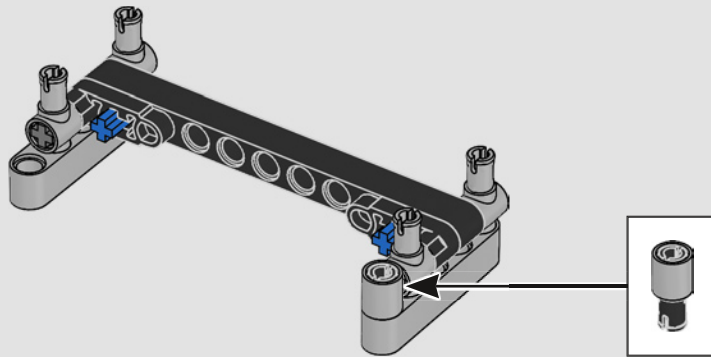

107

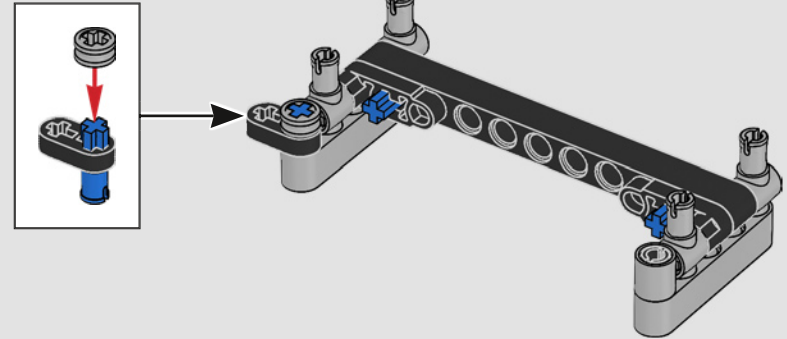

108

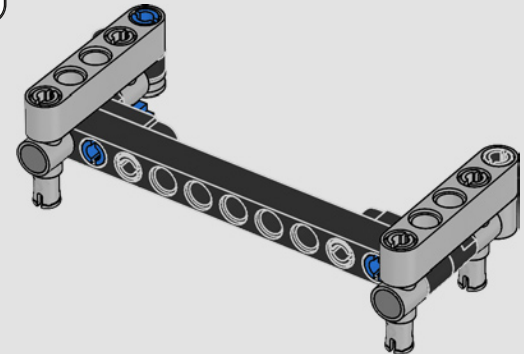

109

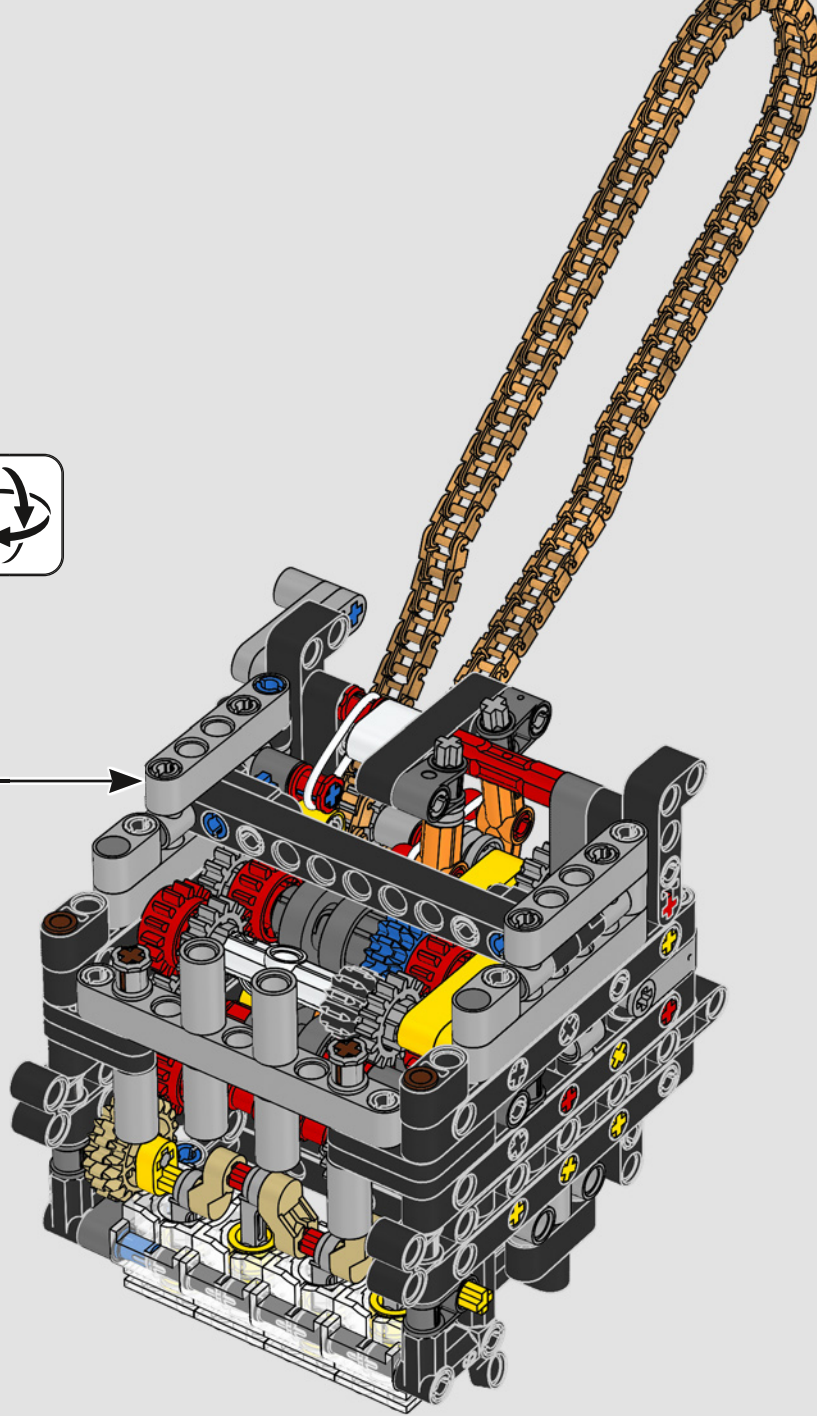

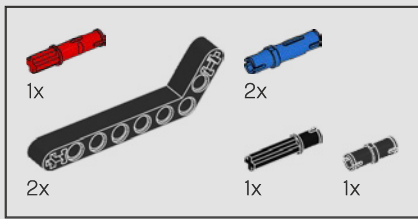

110

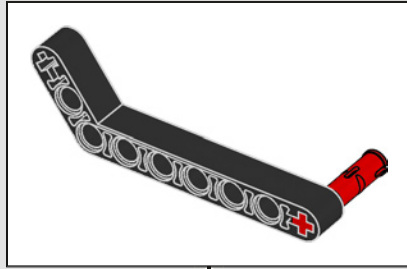

1

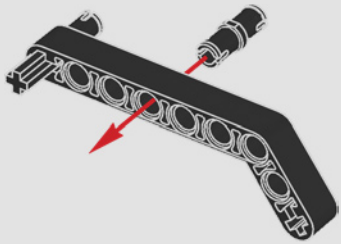

2

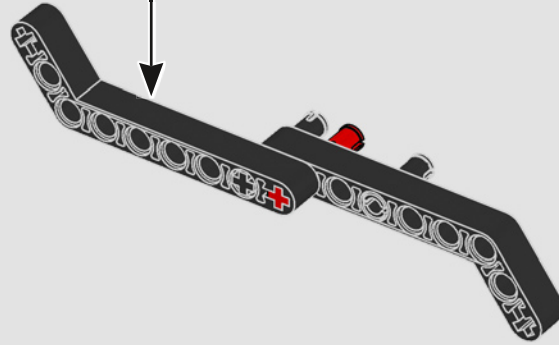

3

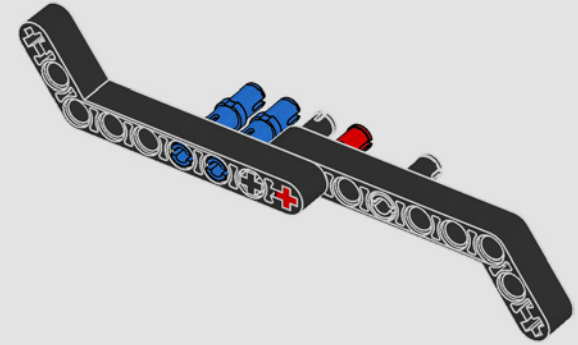

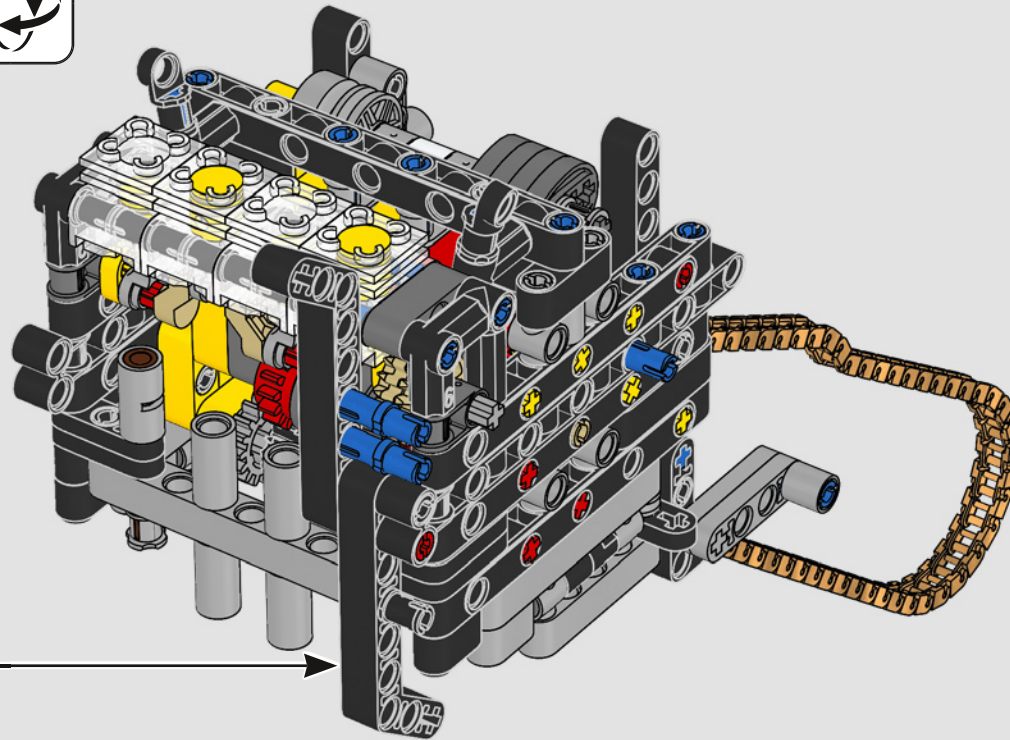

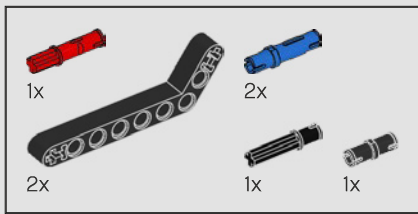

111

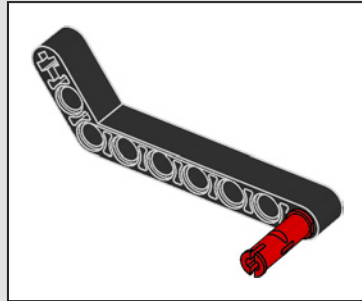

1

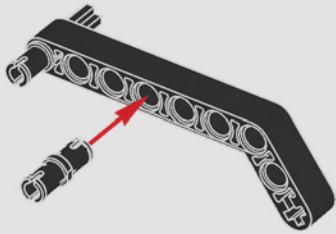

2

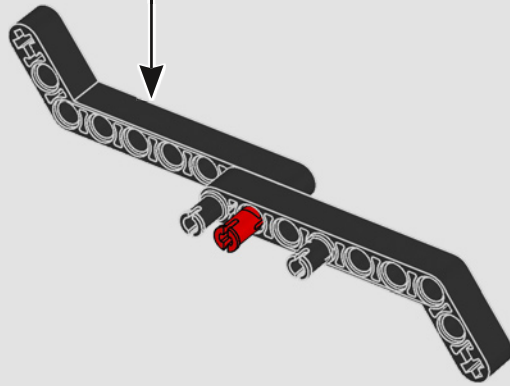

3

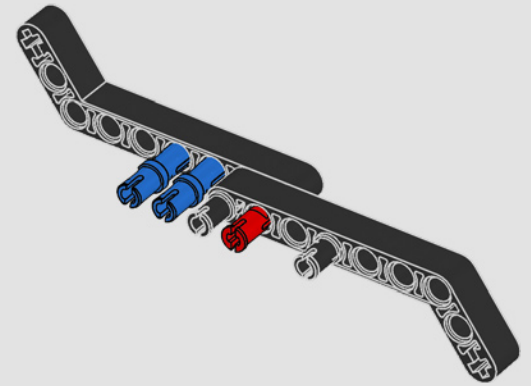

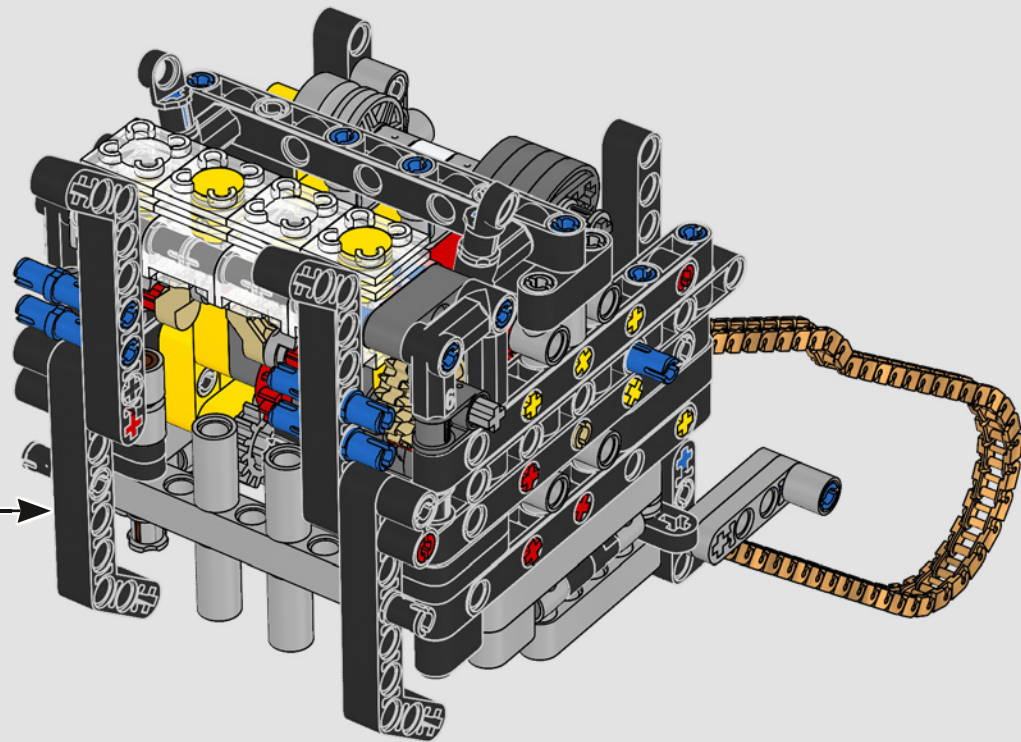

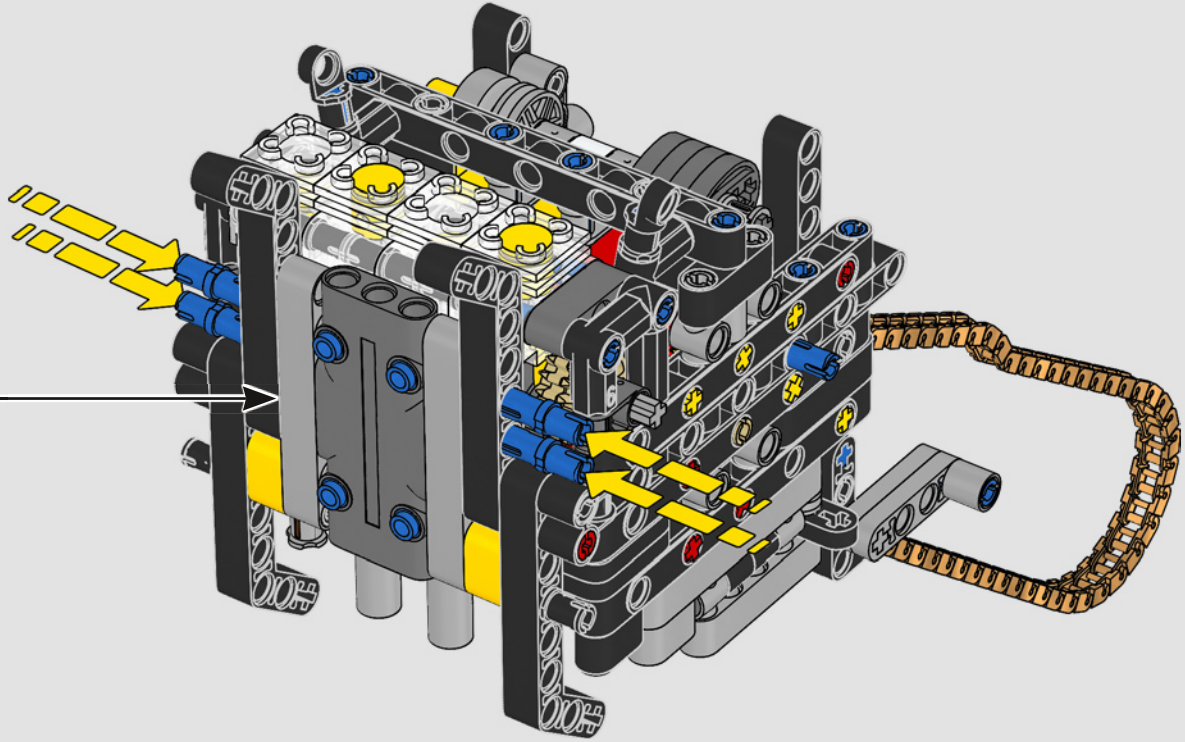

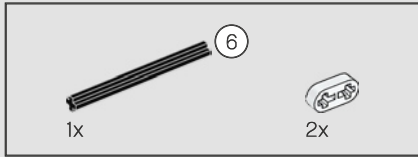
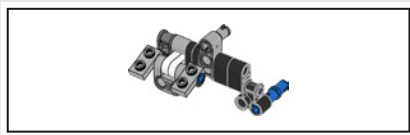

116

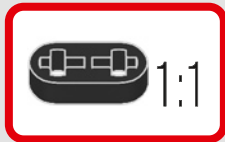
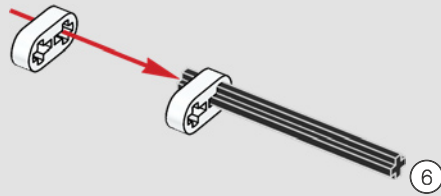

117

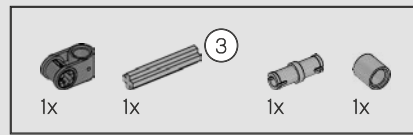
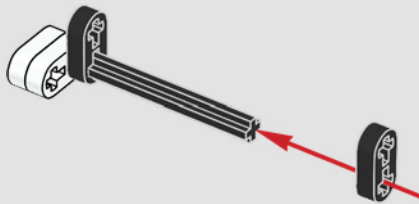

118

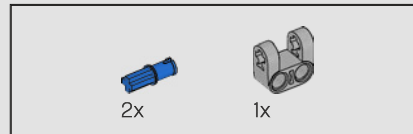
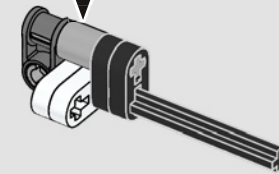
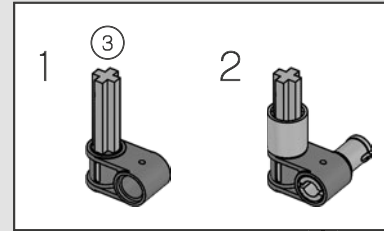

119

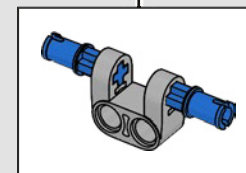
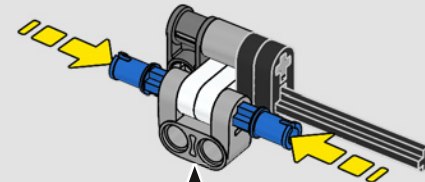



2x

120

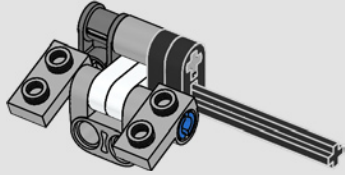

1x



1x

121

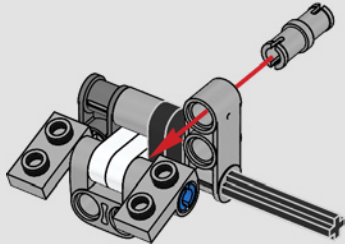

2x

122

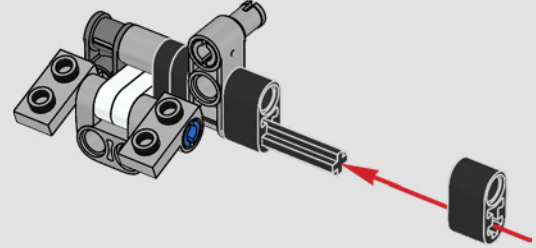

1:1



1x



1x

123

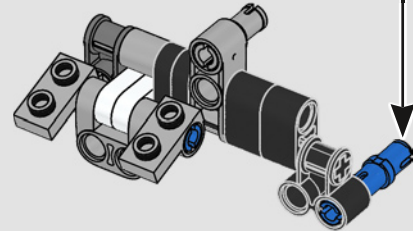
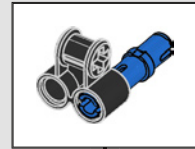

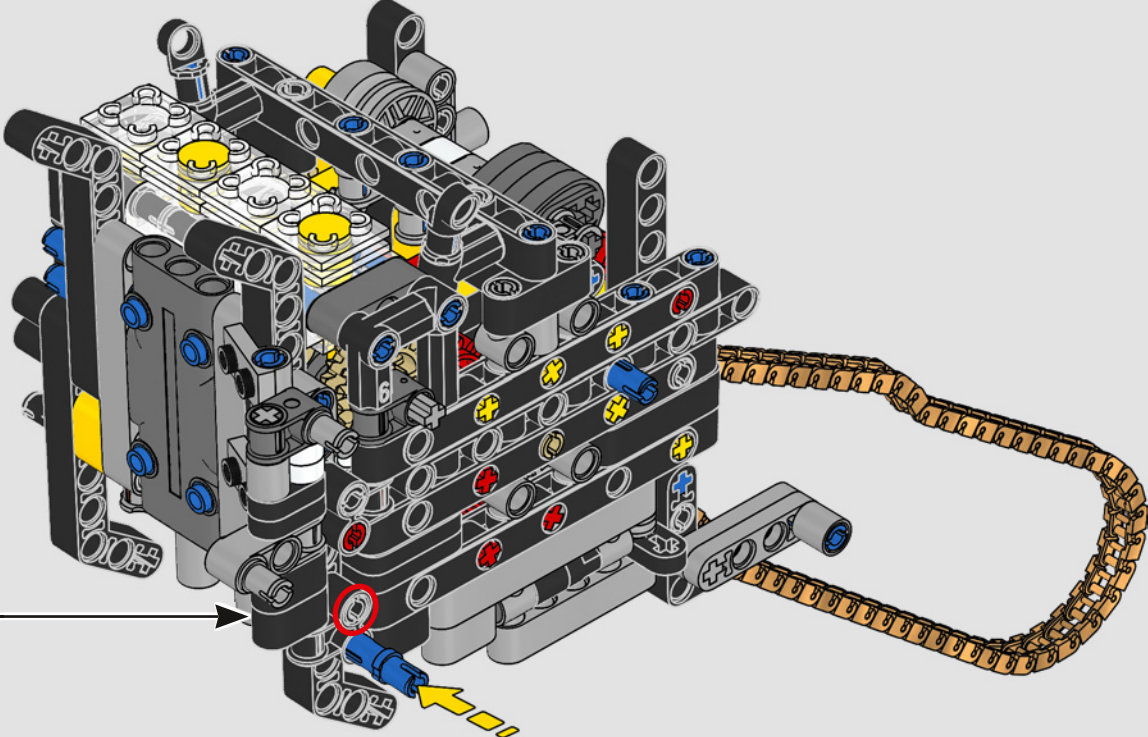

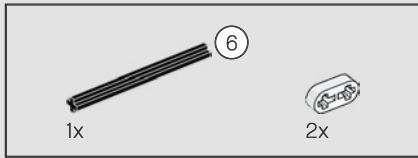
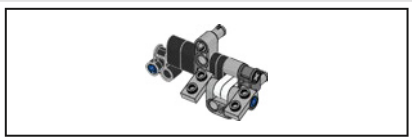

125

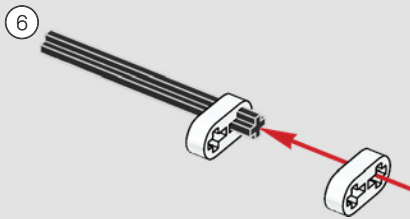

126

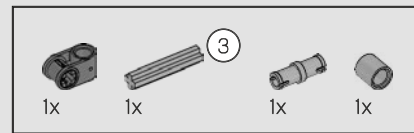
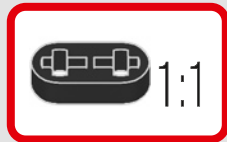
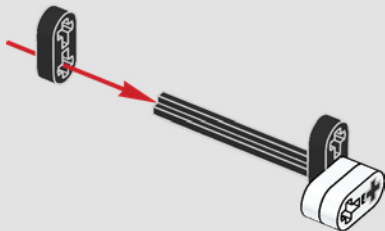

127

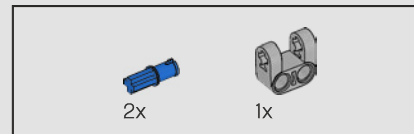
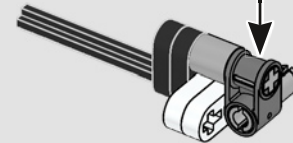
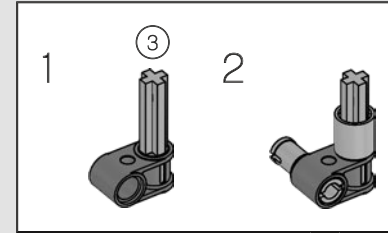

128

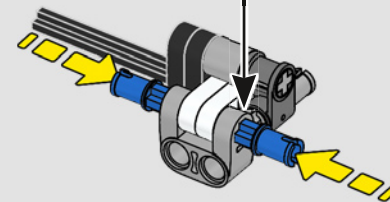
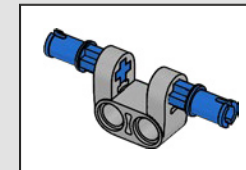

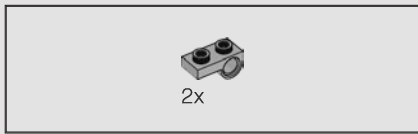

129

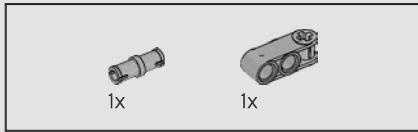
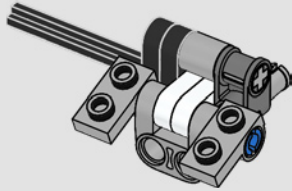

130

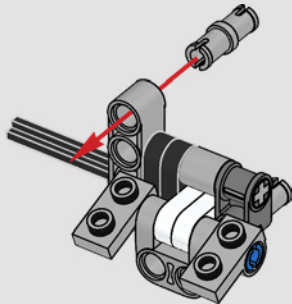

131

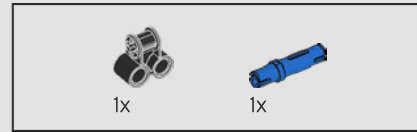
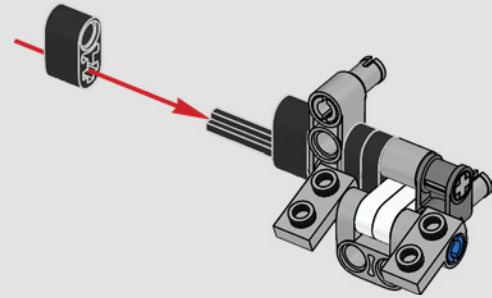

132

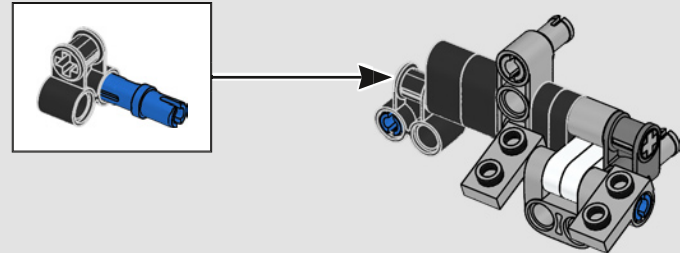

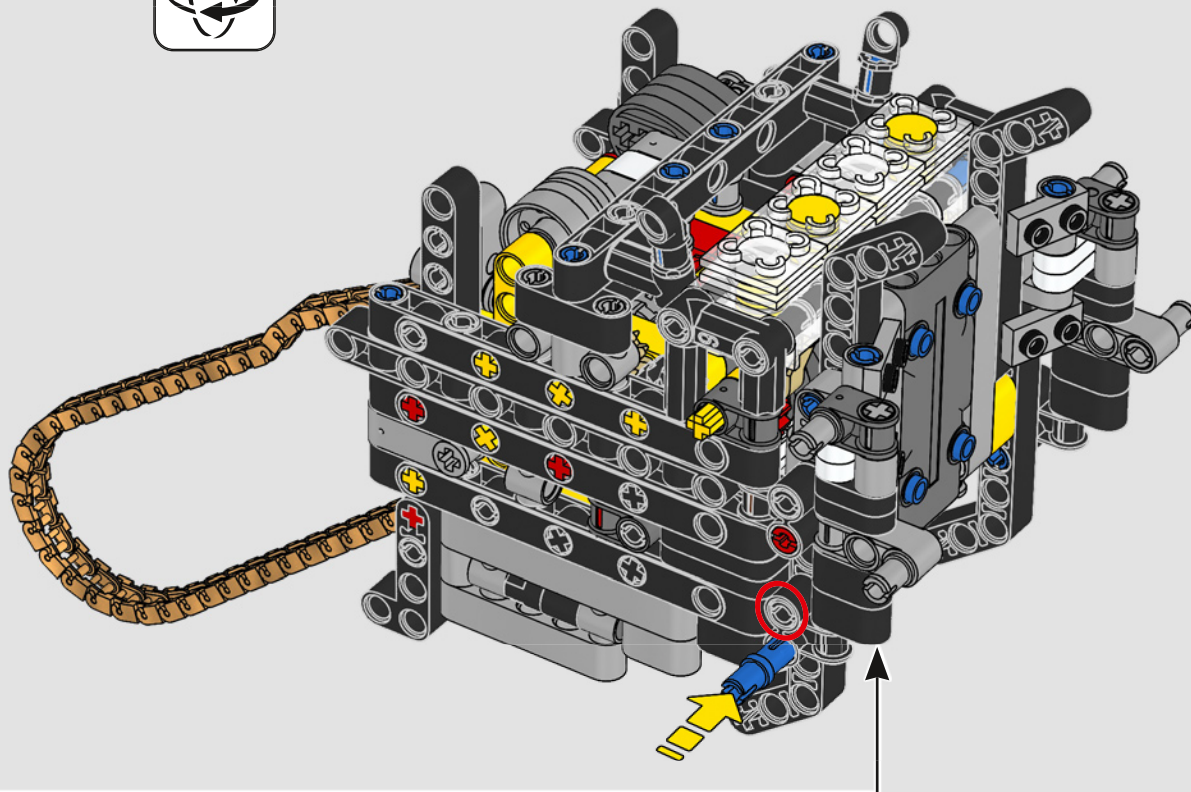

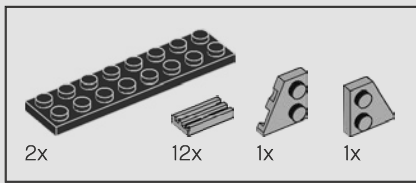

134

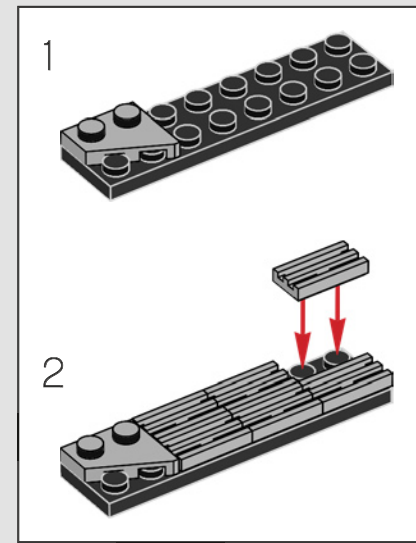
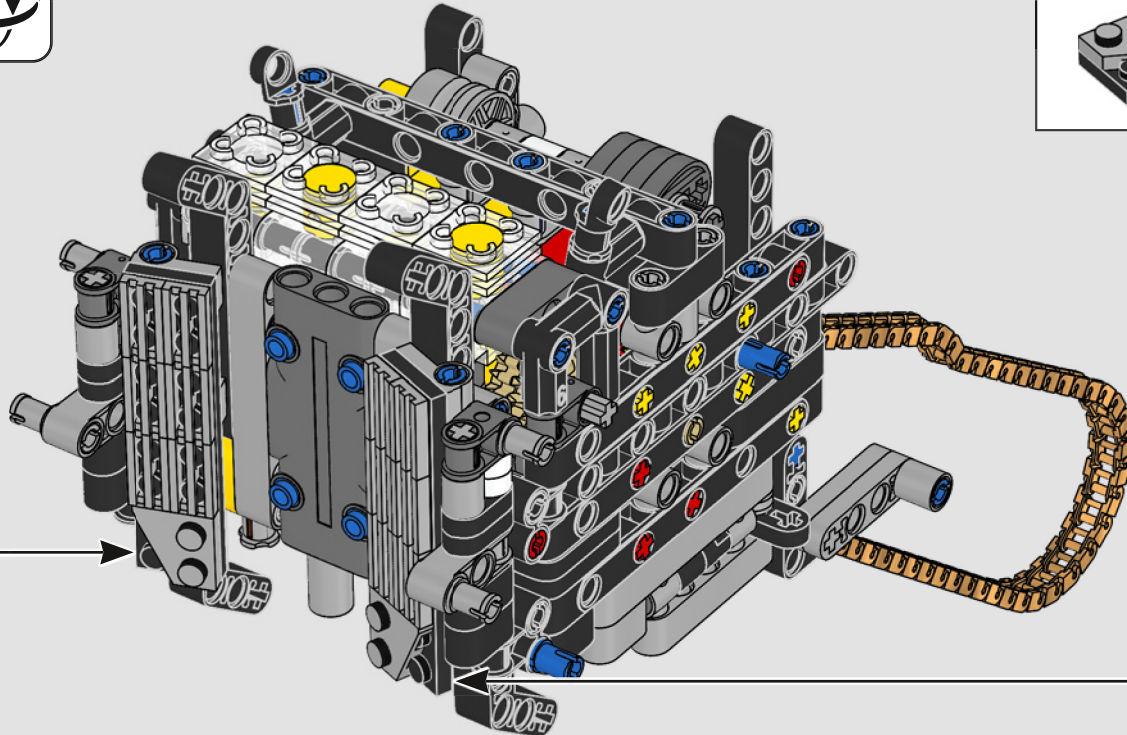
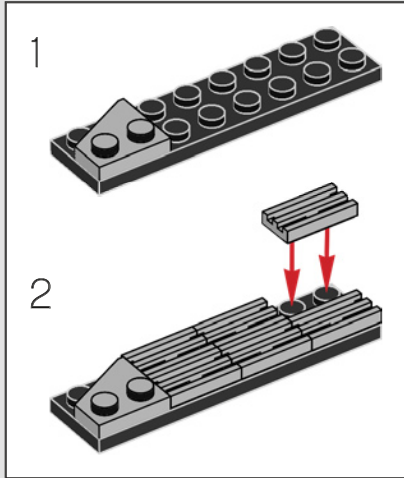

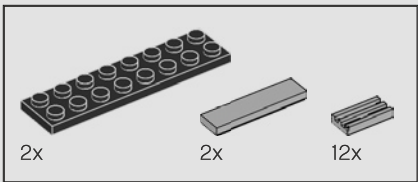

135

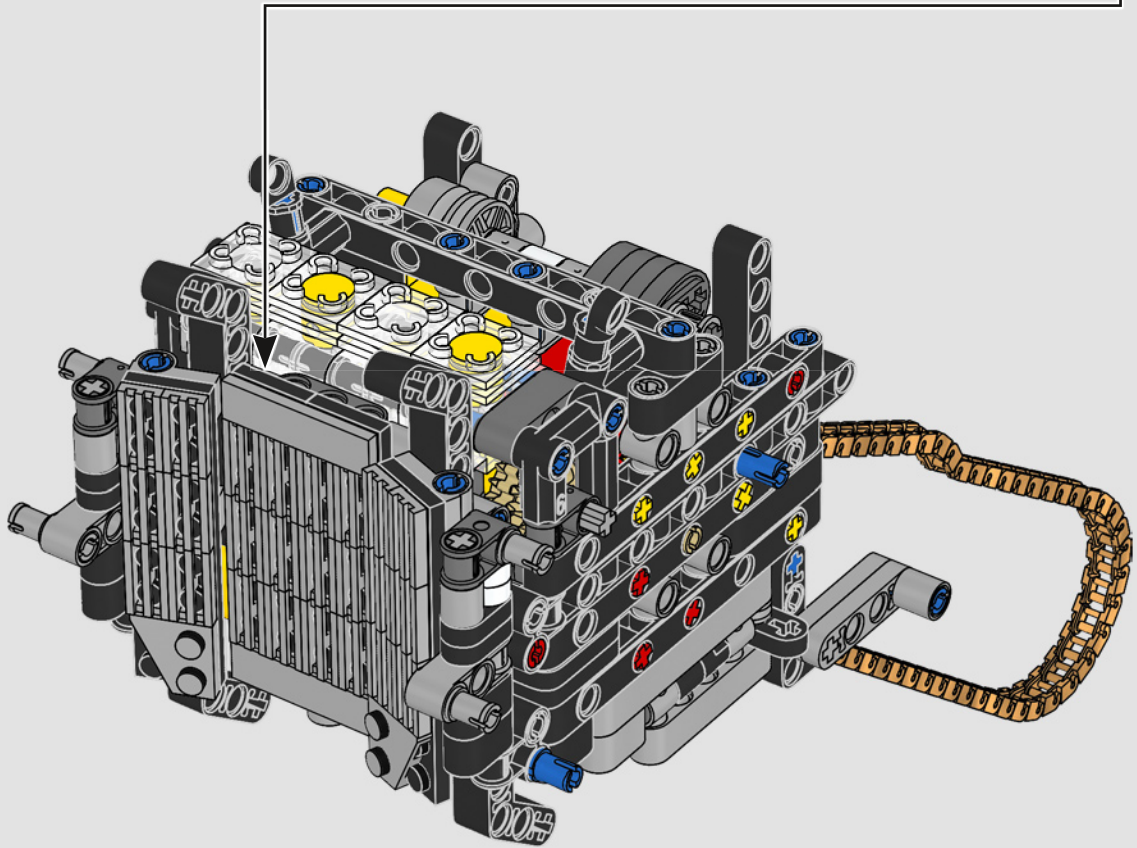
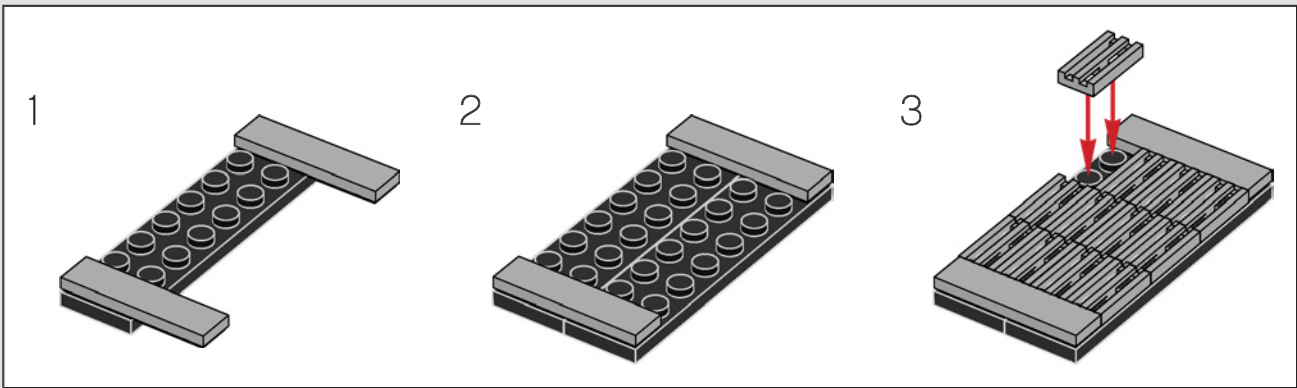

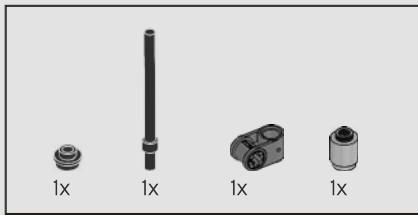

136

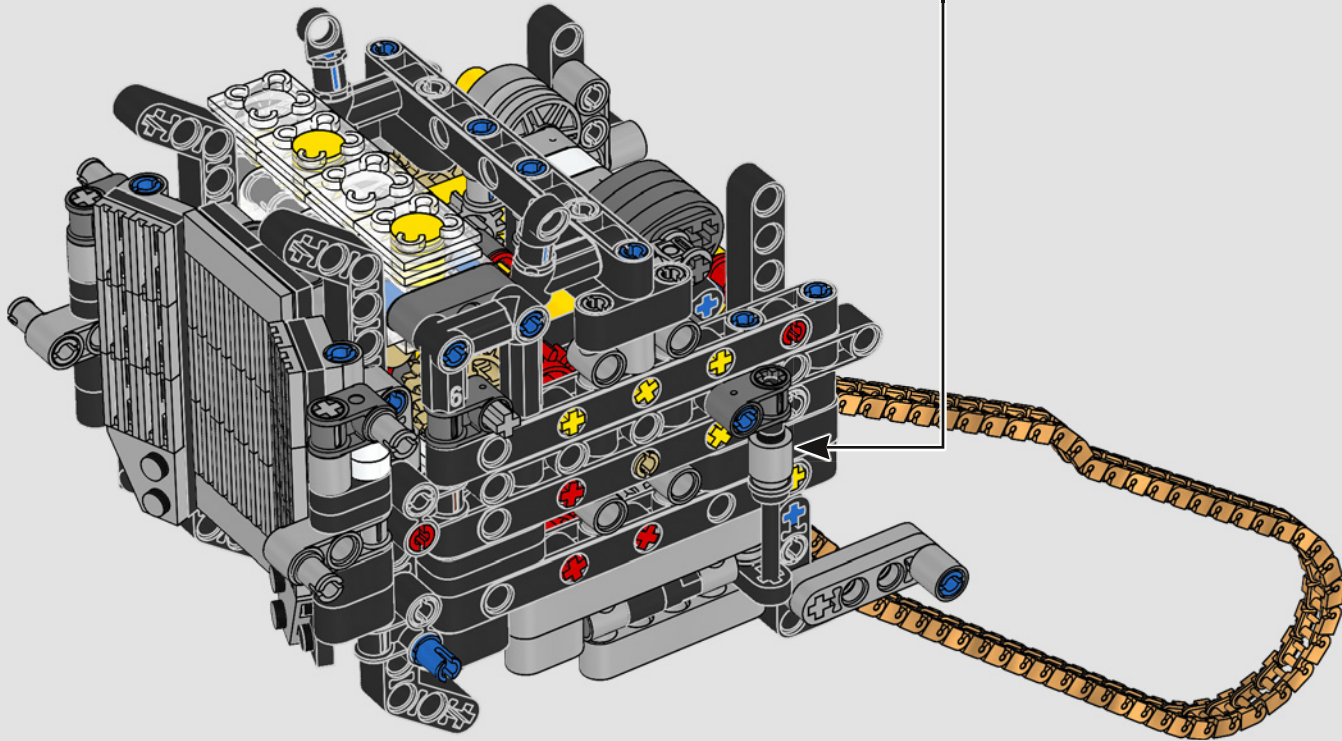
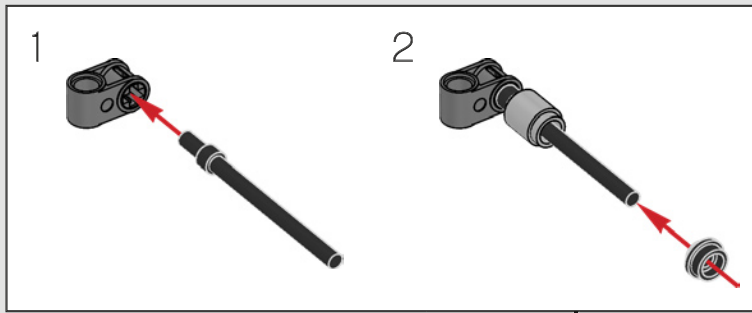

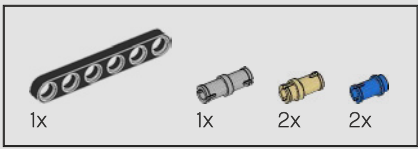

137

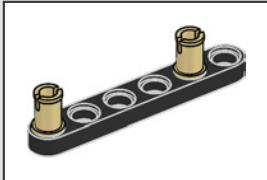
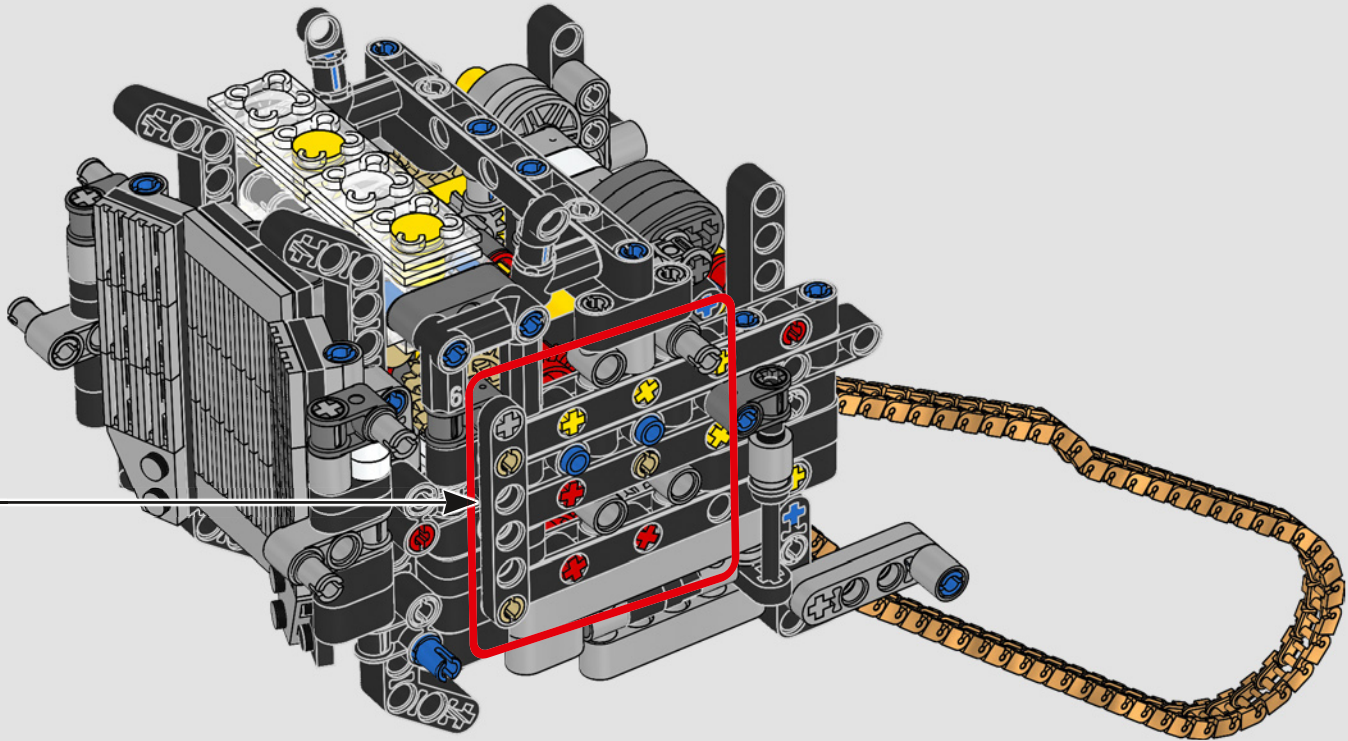

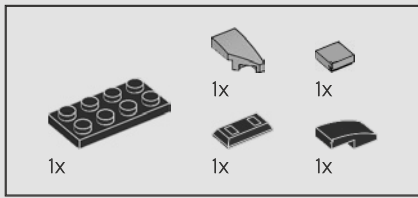

138

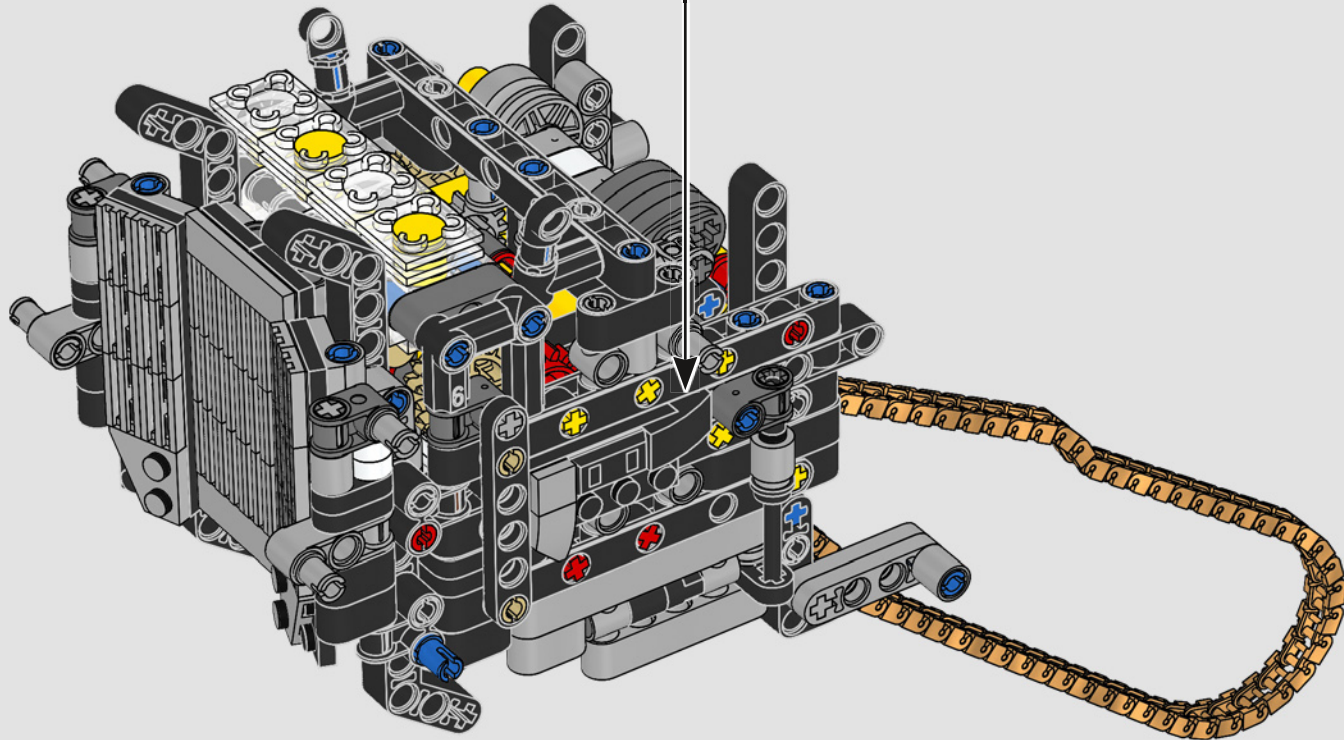
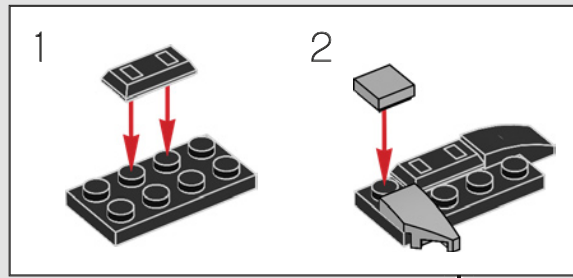

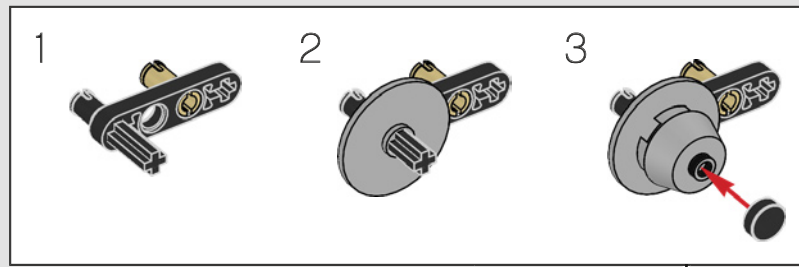
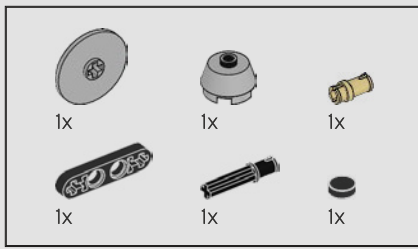

139

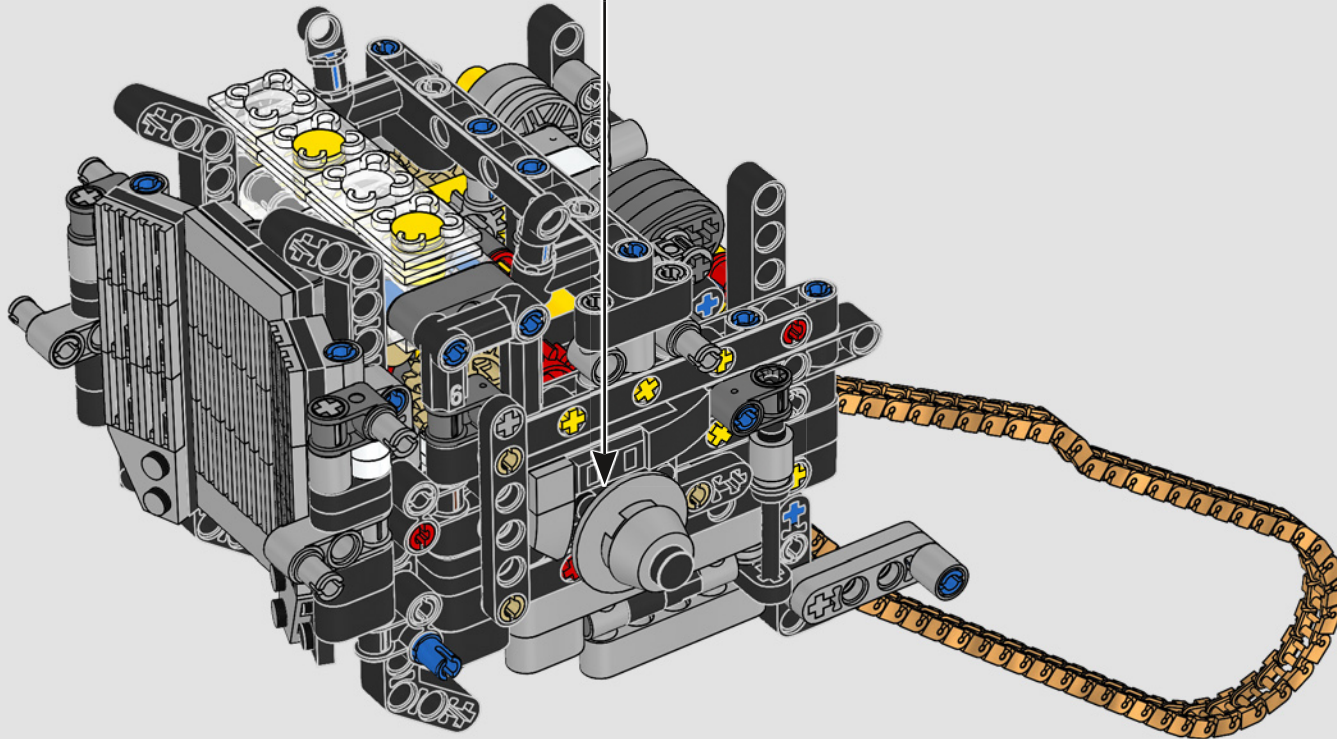

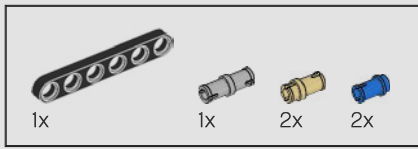

140

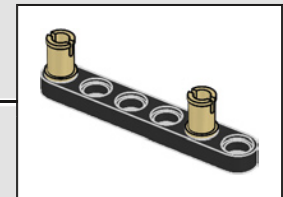
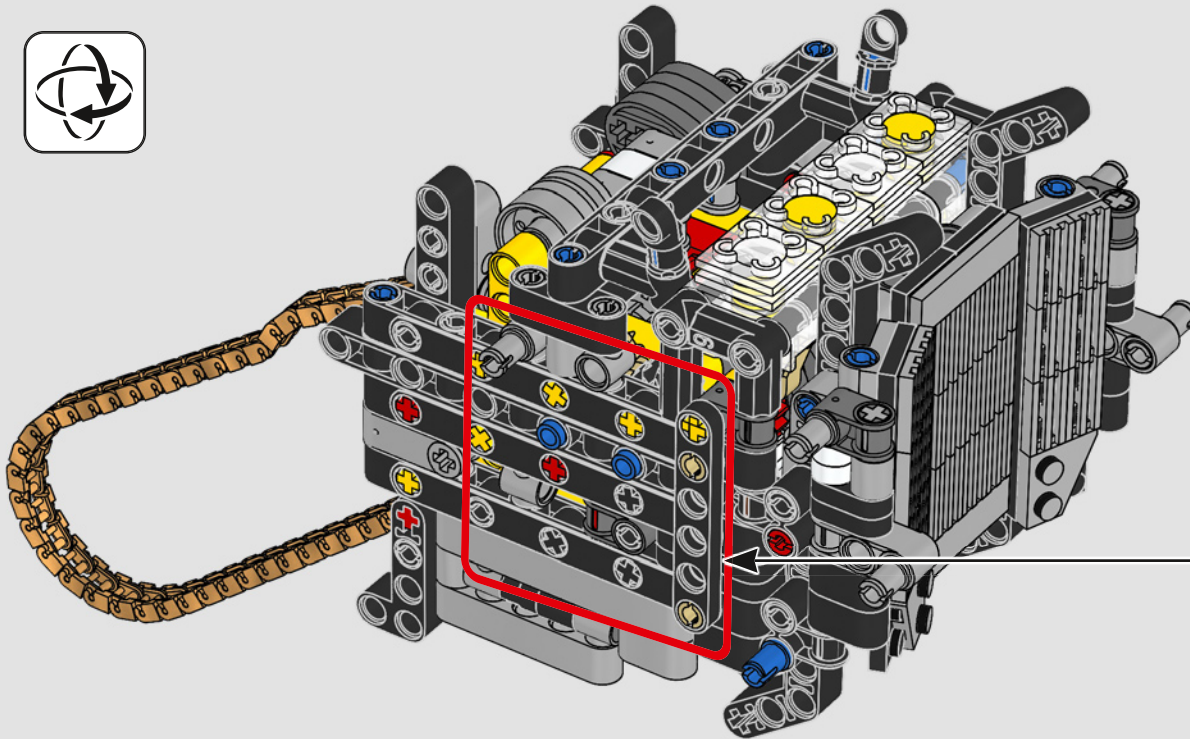

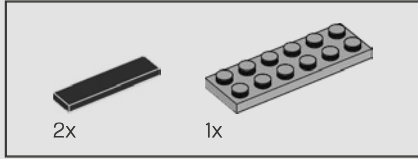
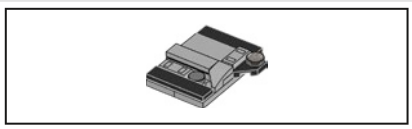

141

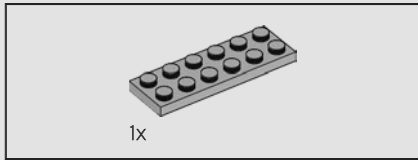
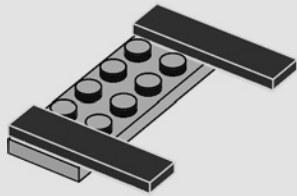

142

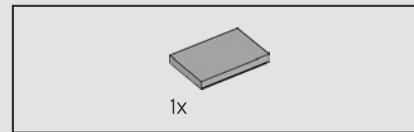
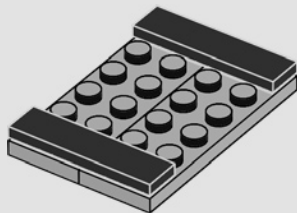

143

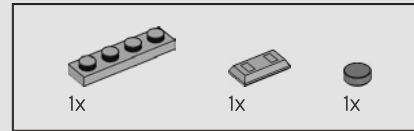
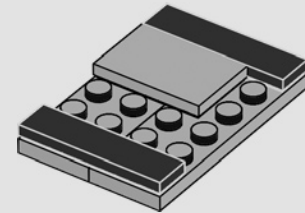

144

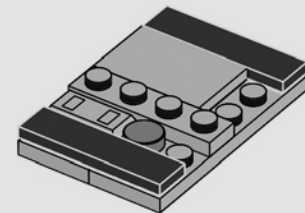

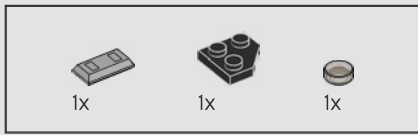

145

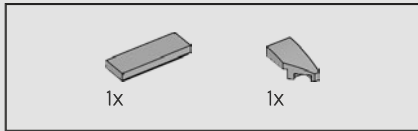
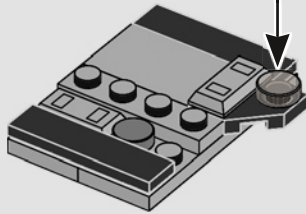
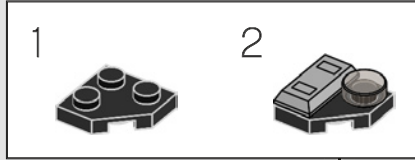

146

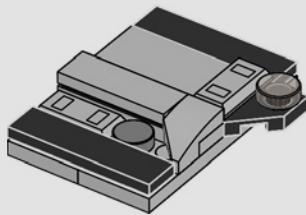

147

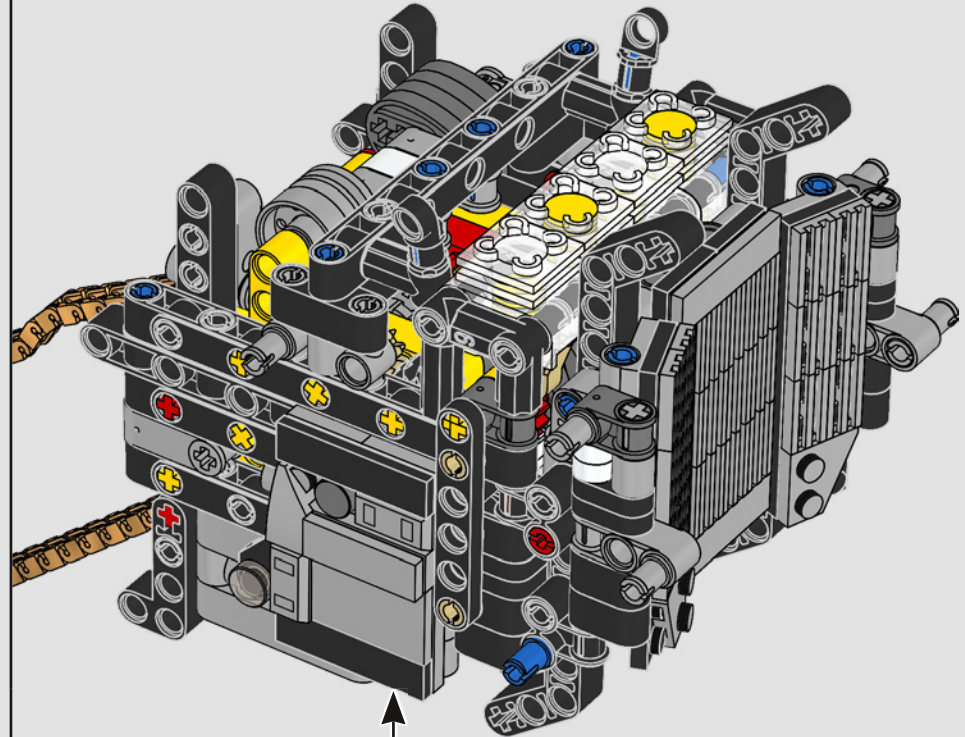

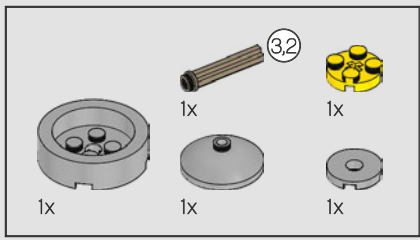

148

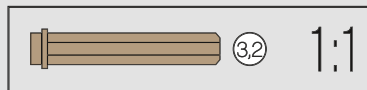
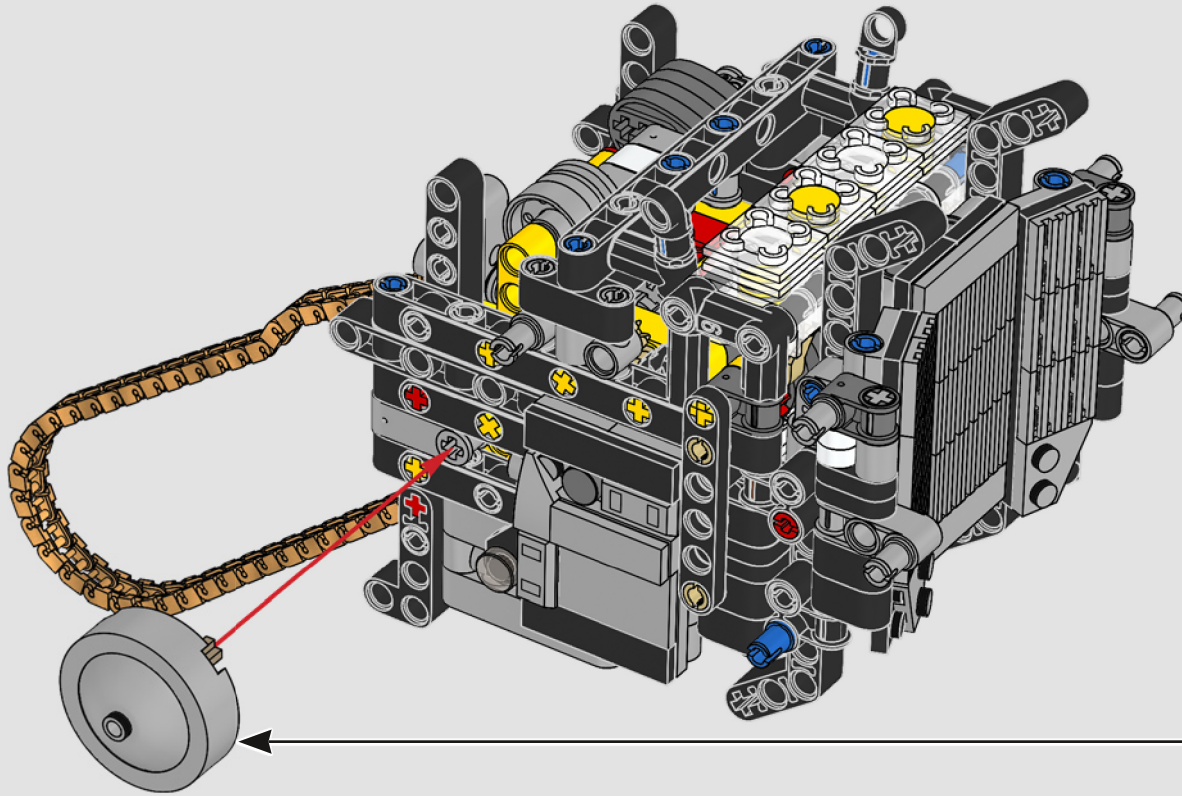
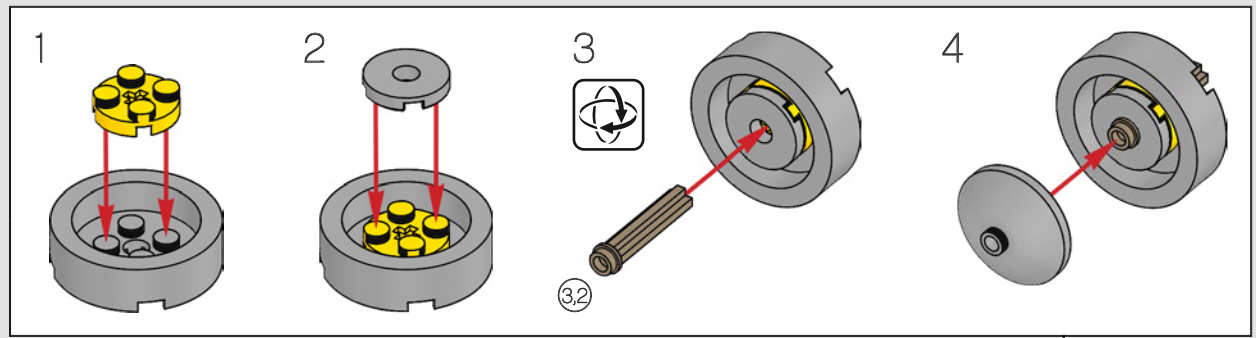

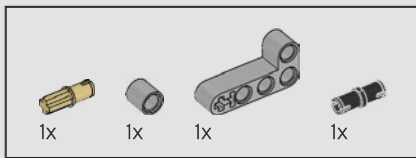

149

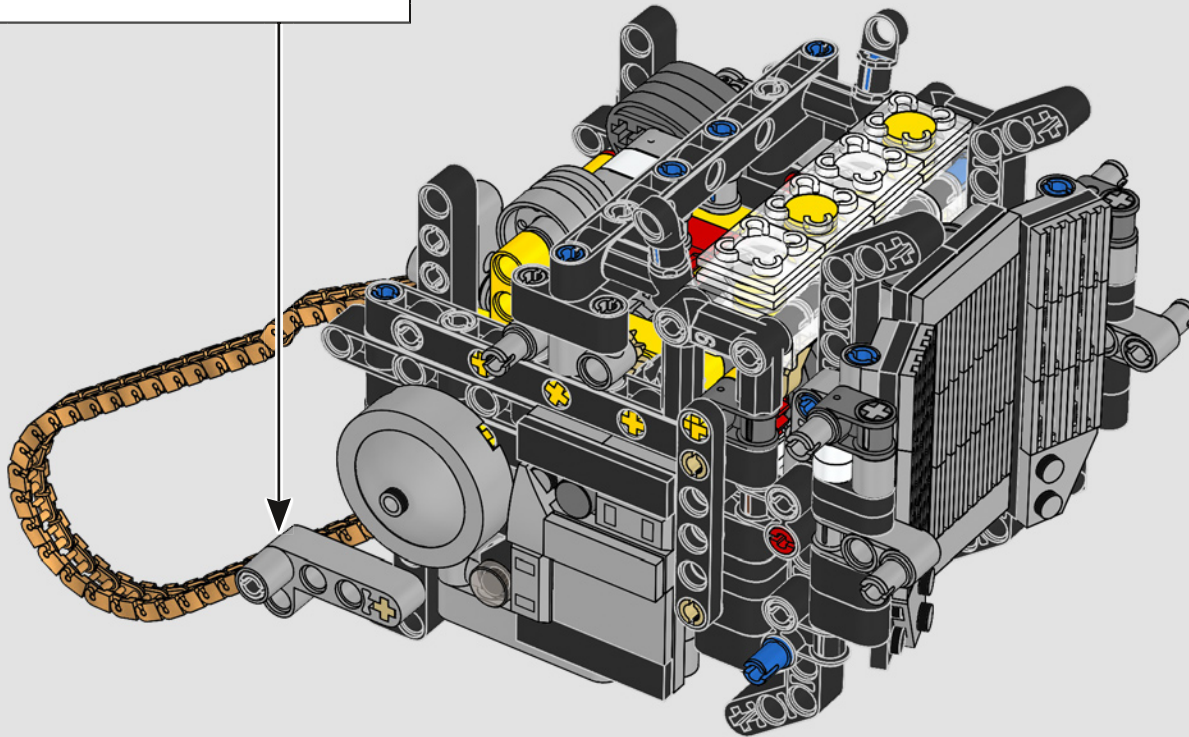
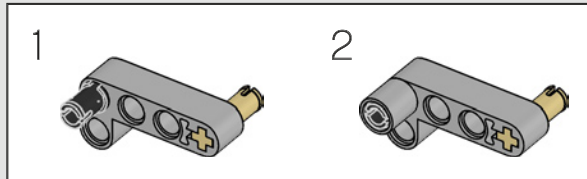

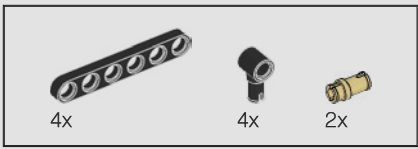

150

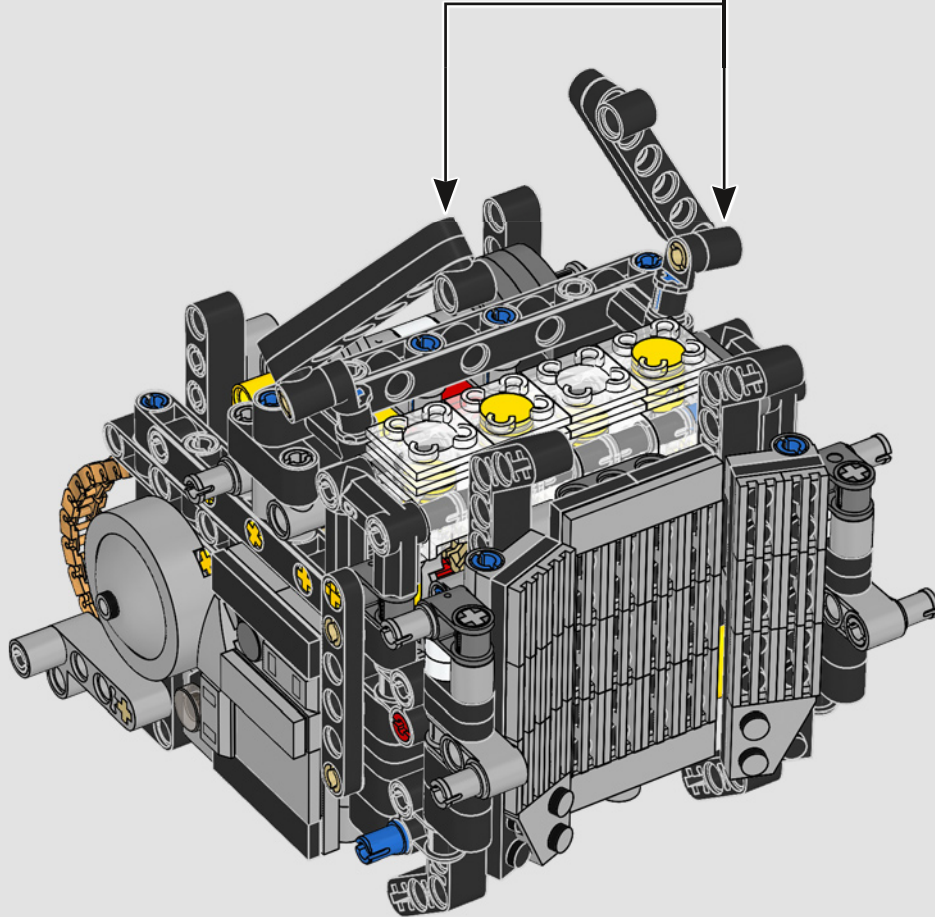
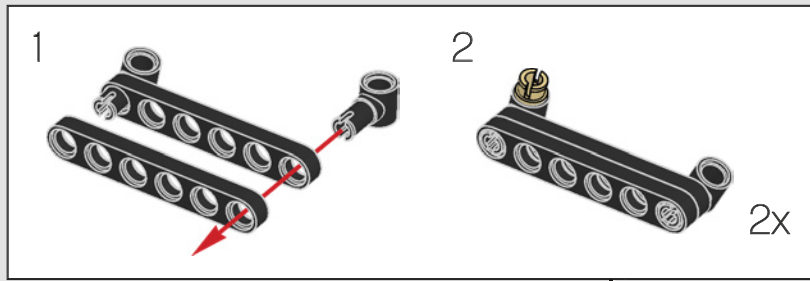

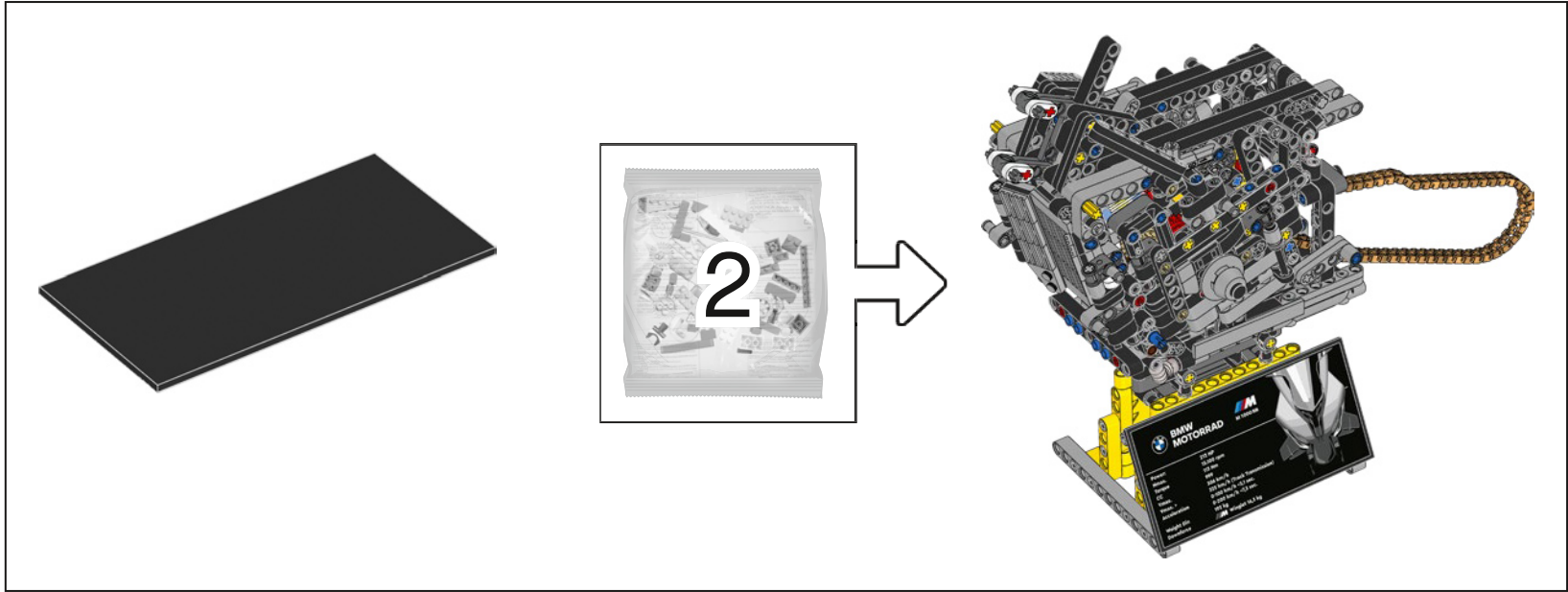

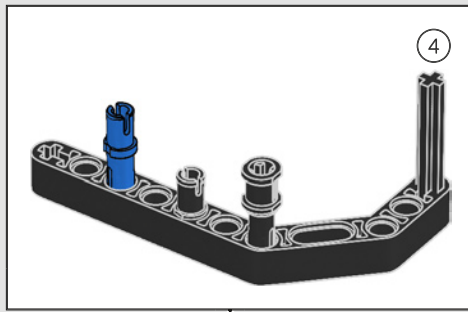
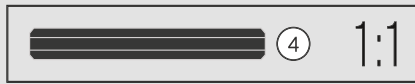
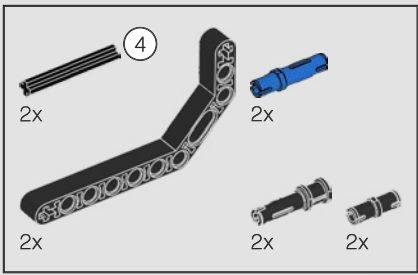

151

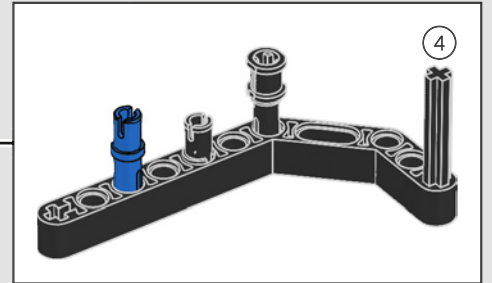
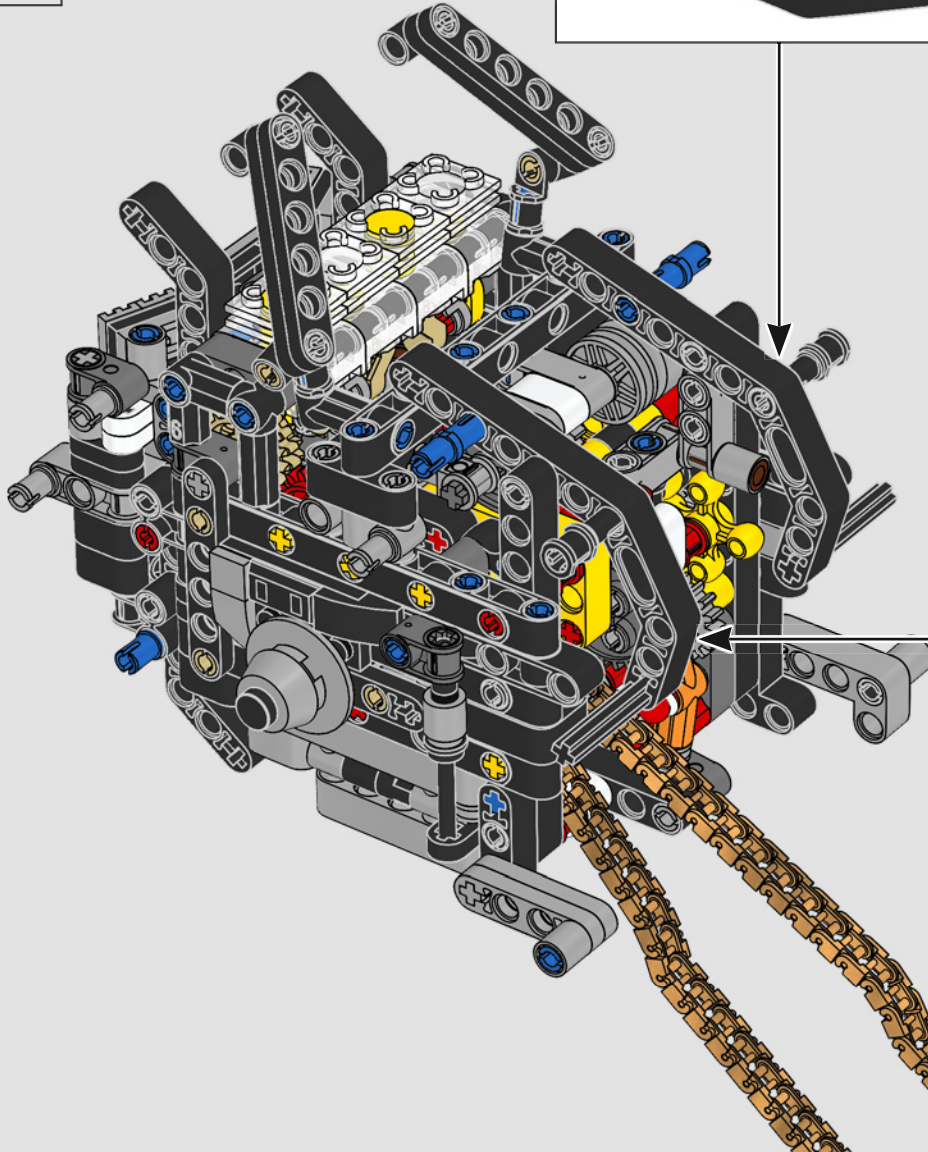

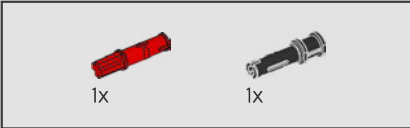
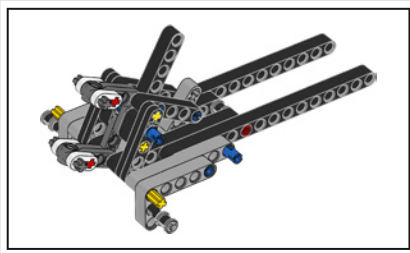

152

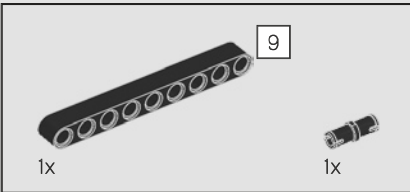
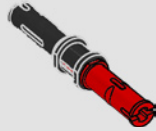

153

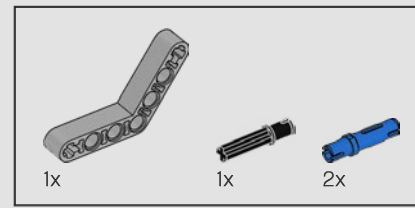
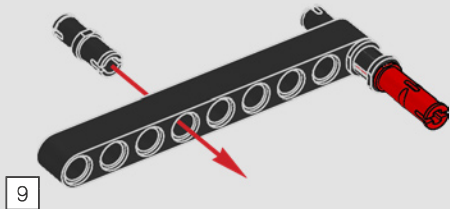

154

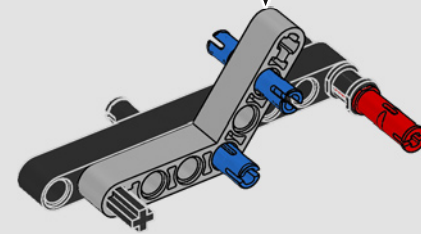
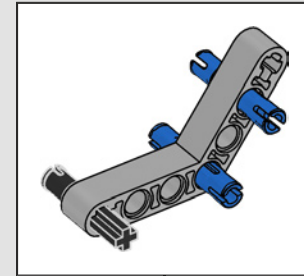

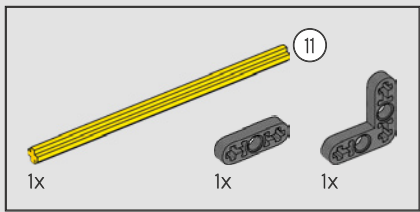

155

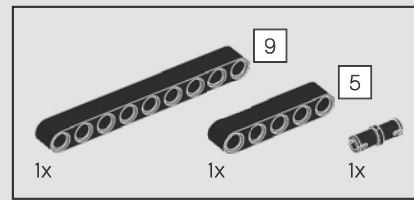
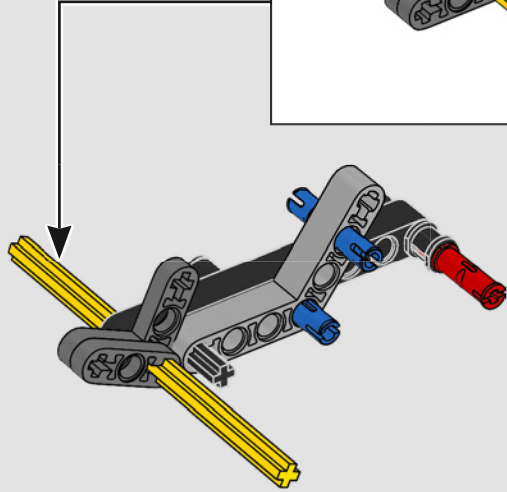
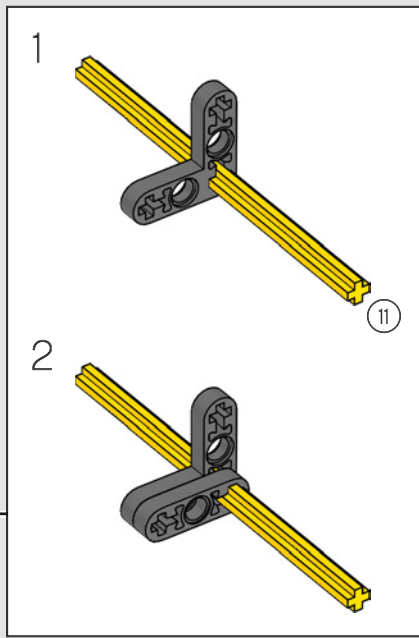

156

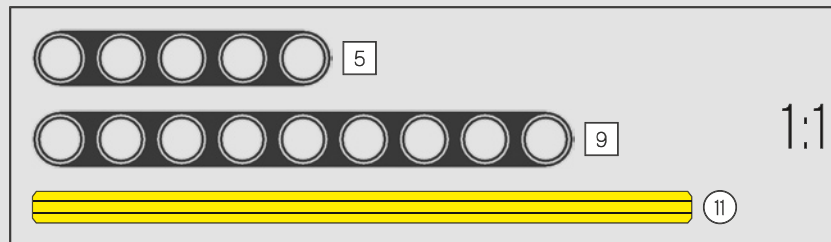
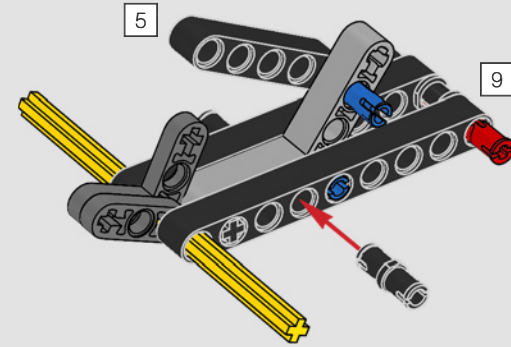

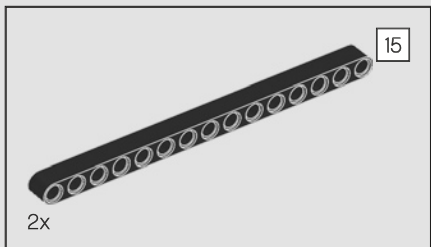

157

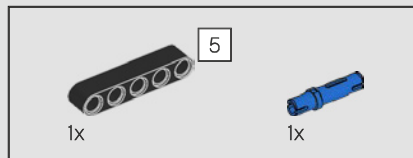
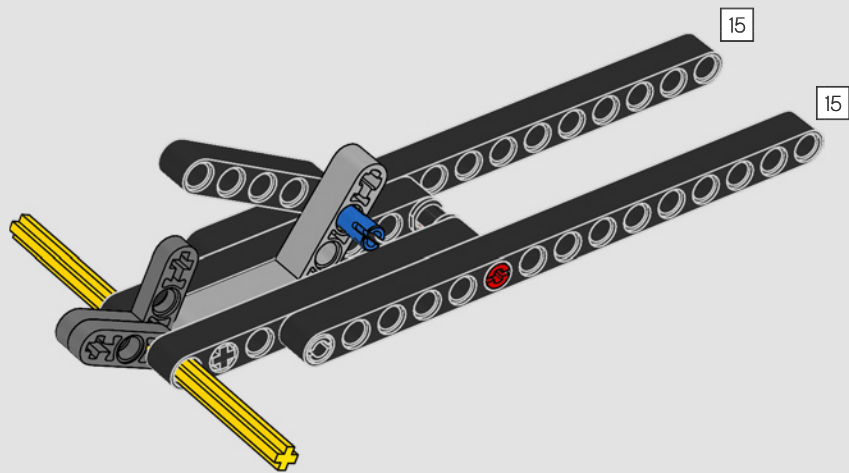

158

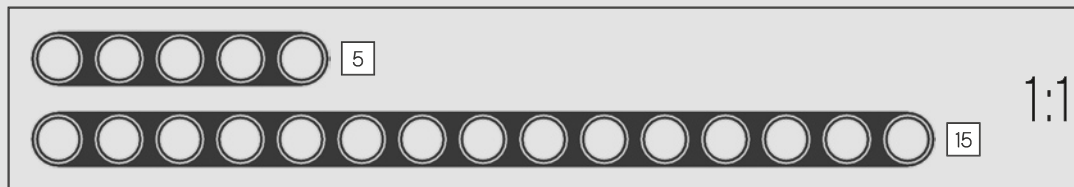
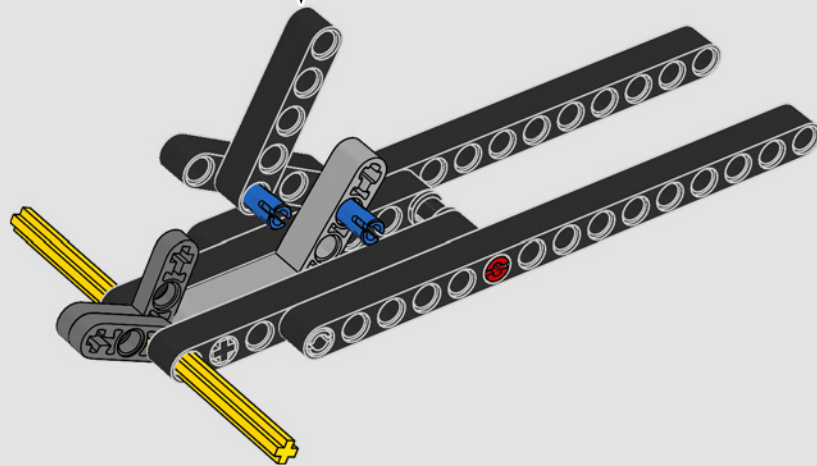
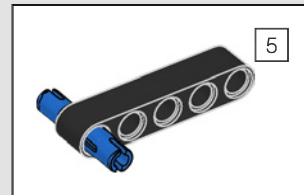

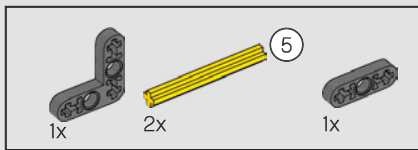

159

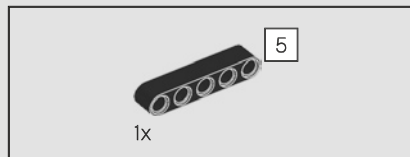
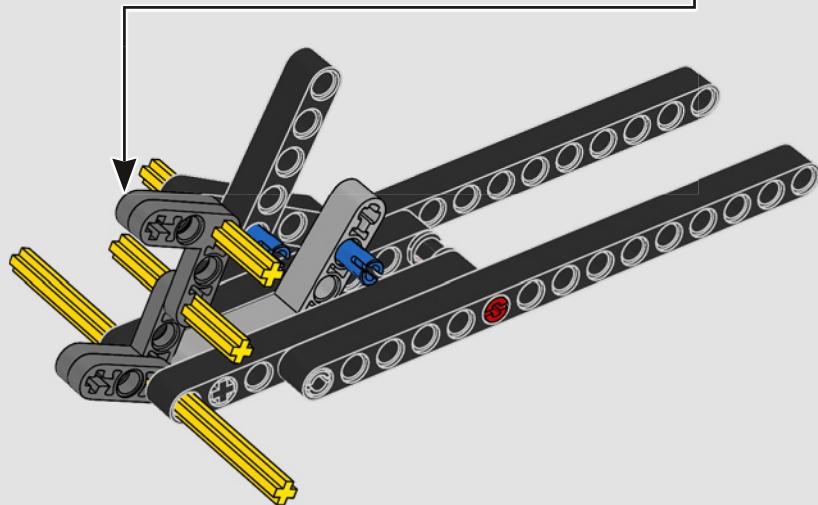
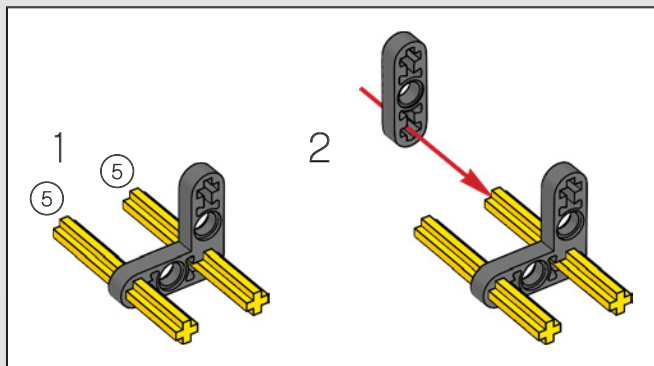

160

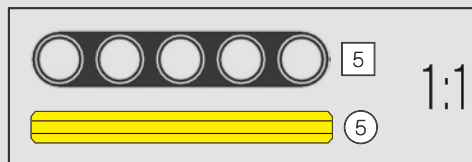
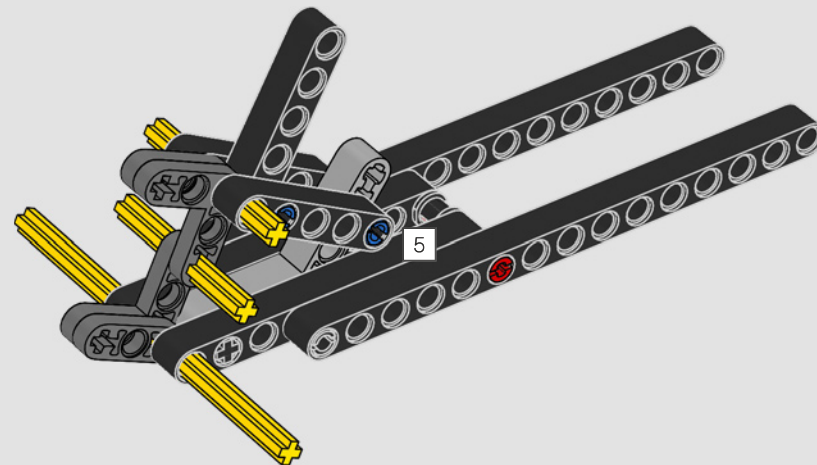



161

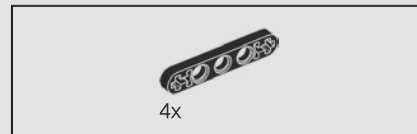
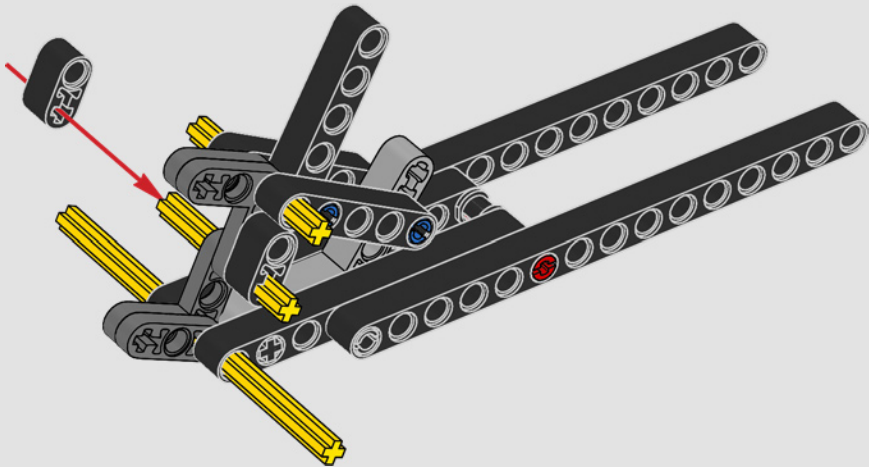

162

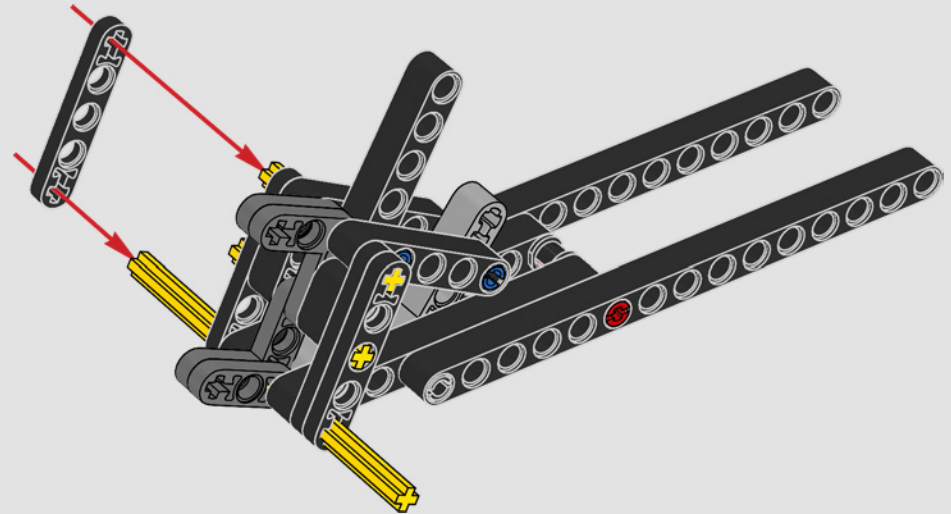

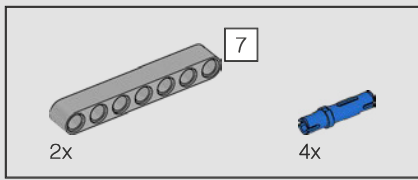

163

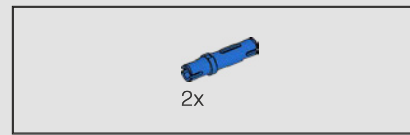
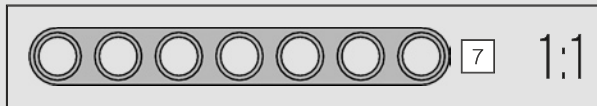
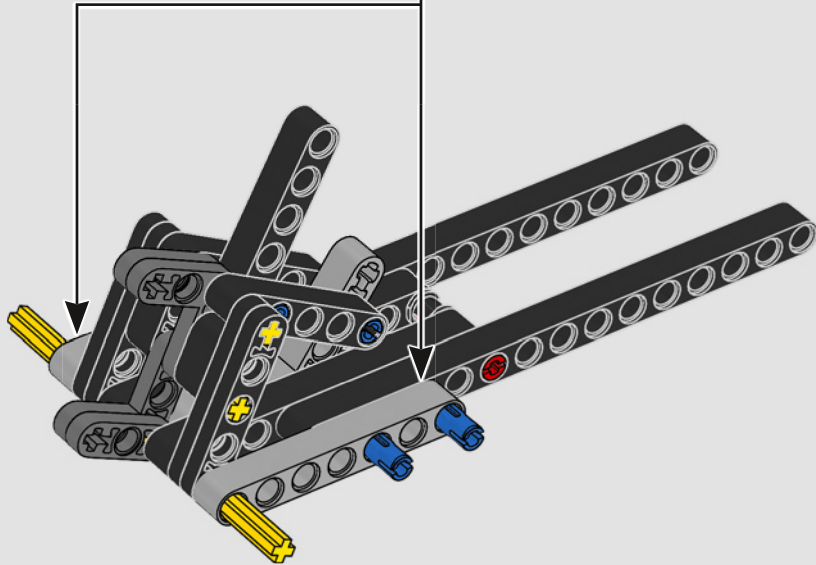
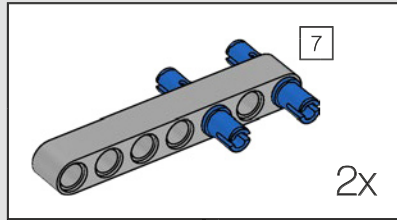

164

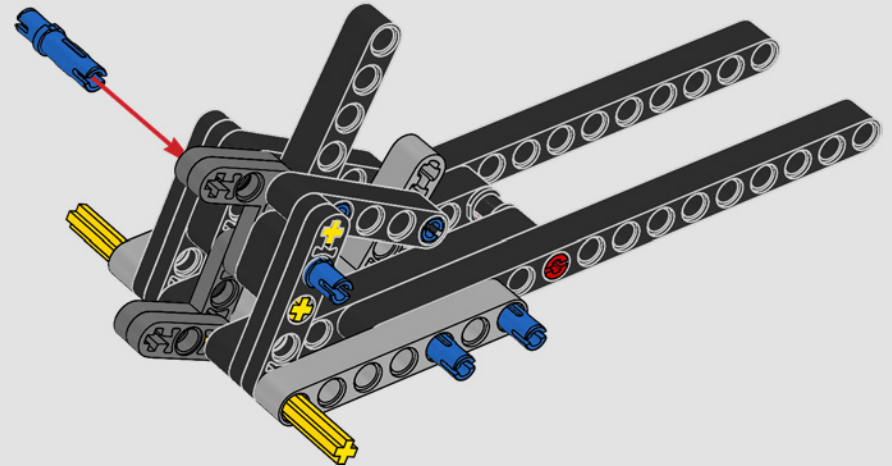

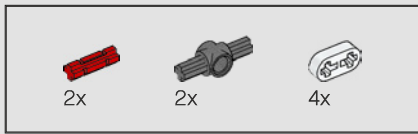

165

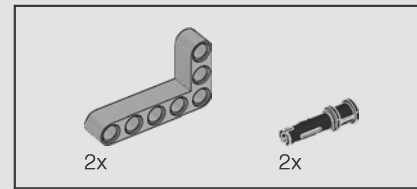
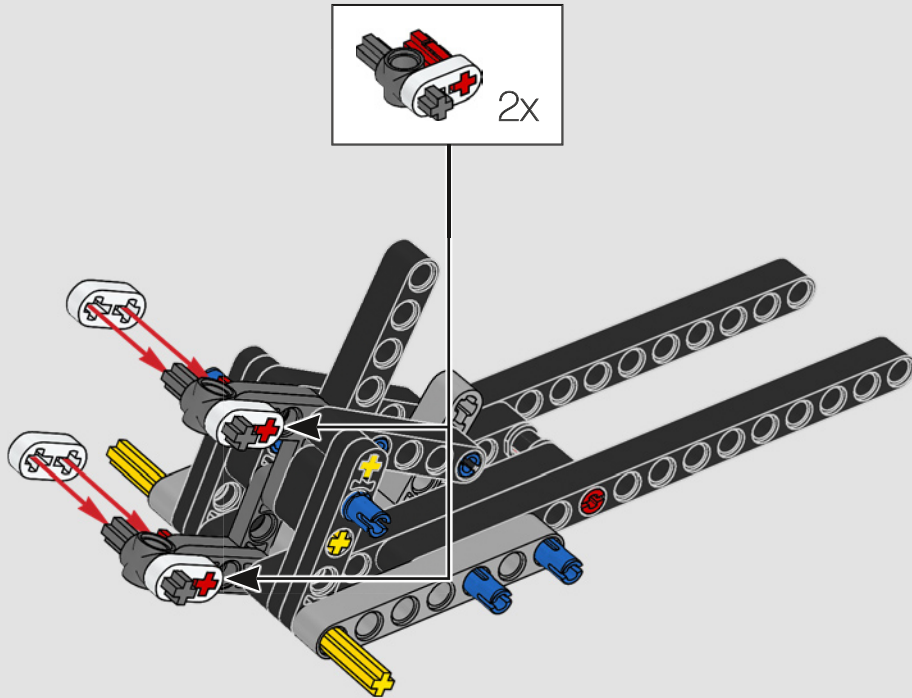

166

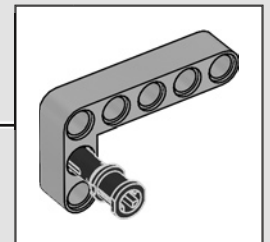
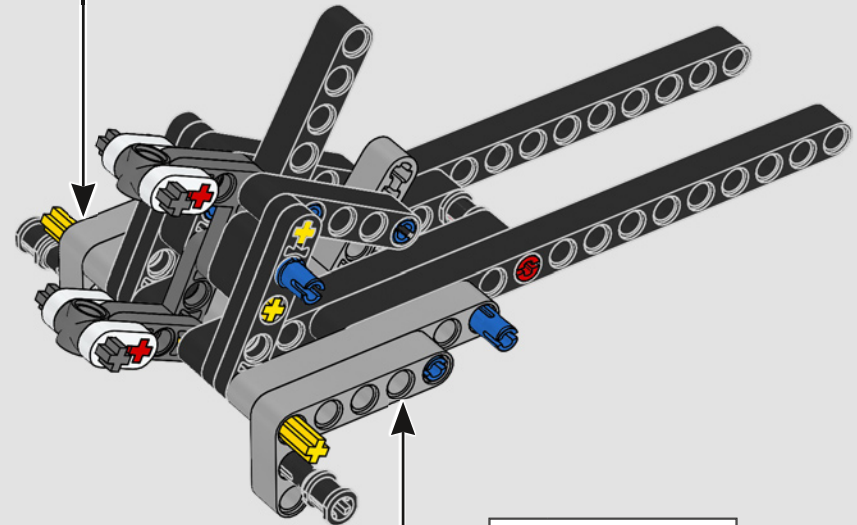
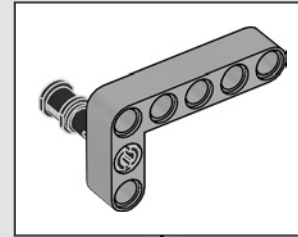

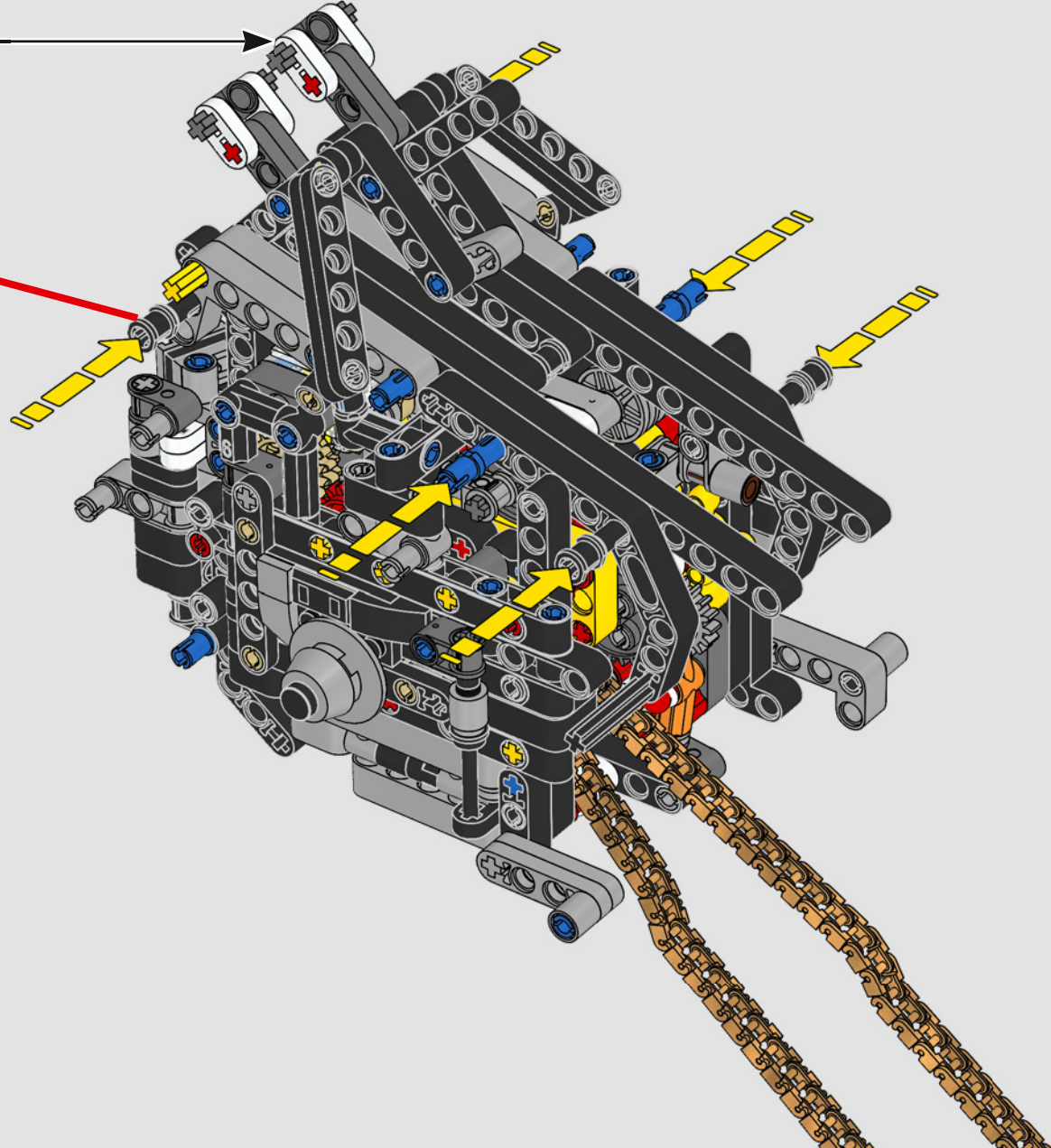
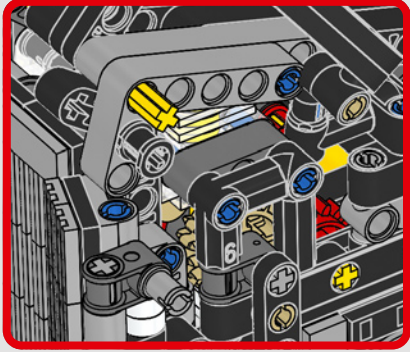

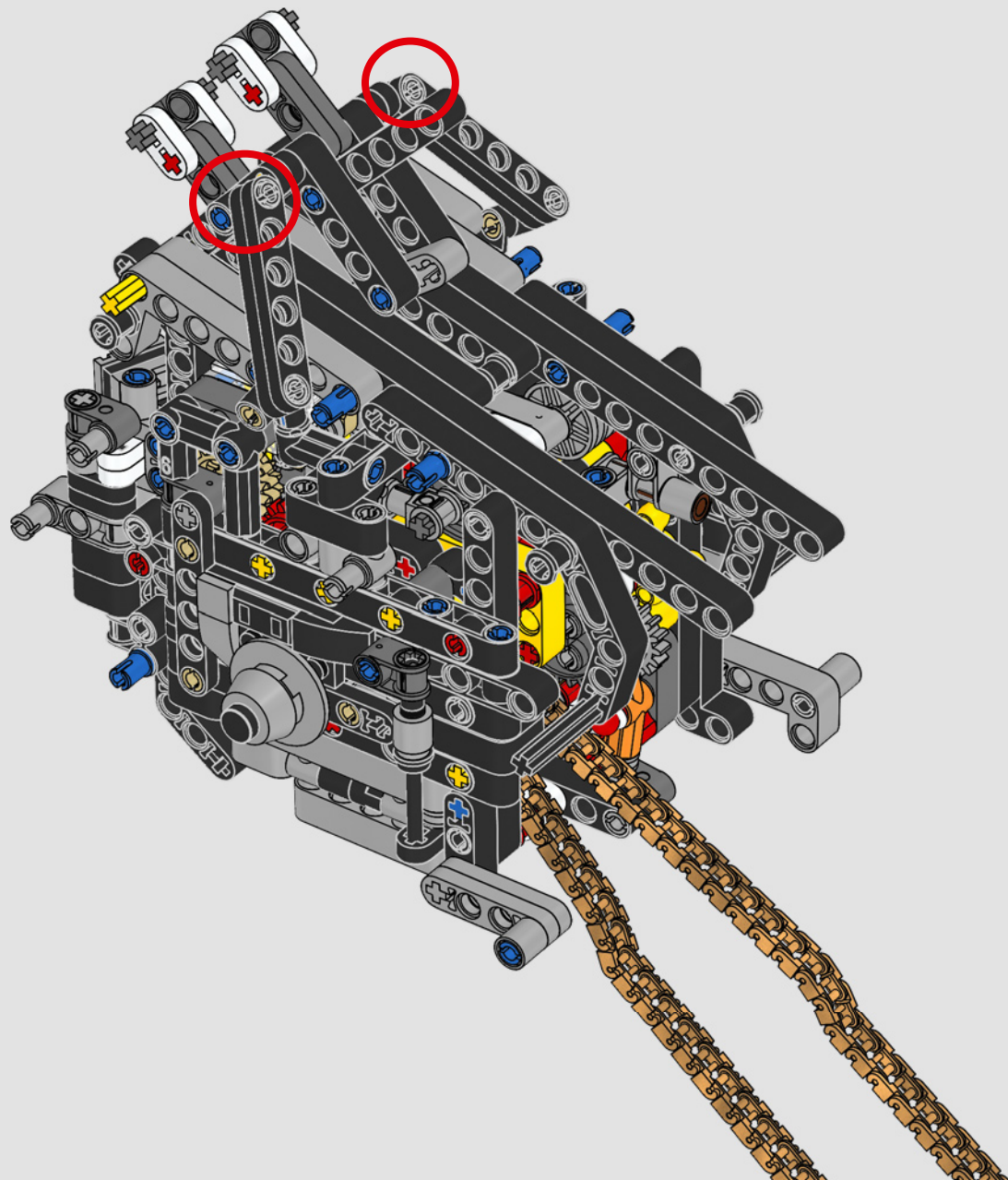

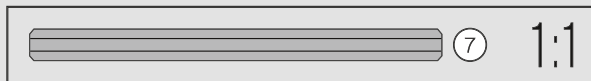
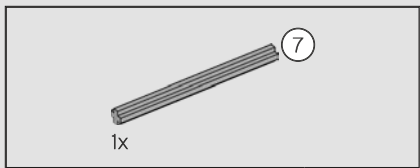

169

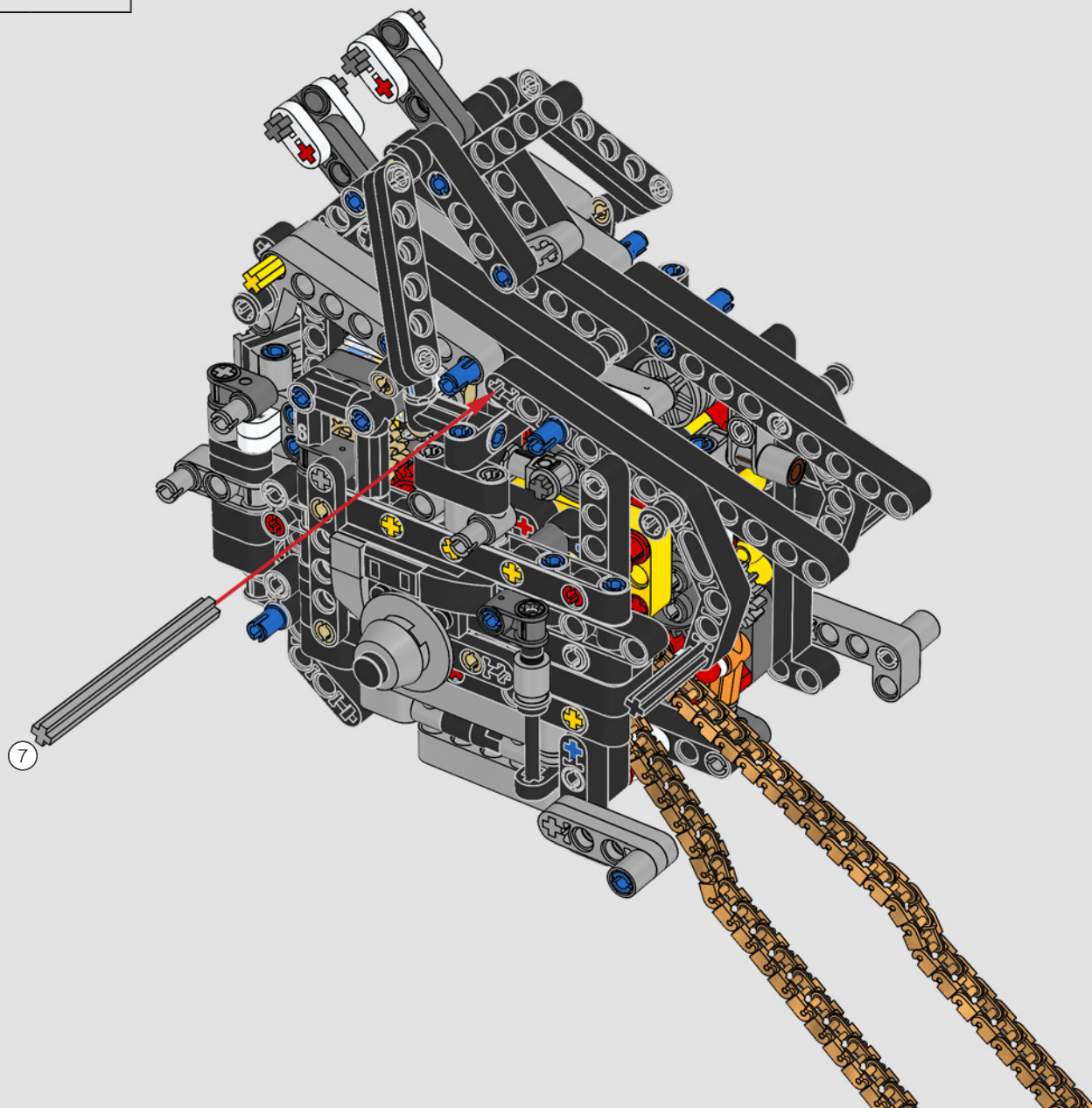



170

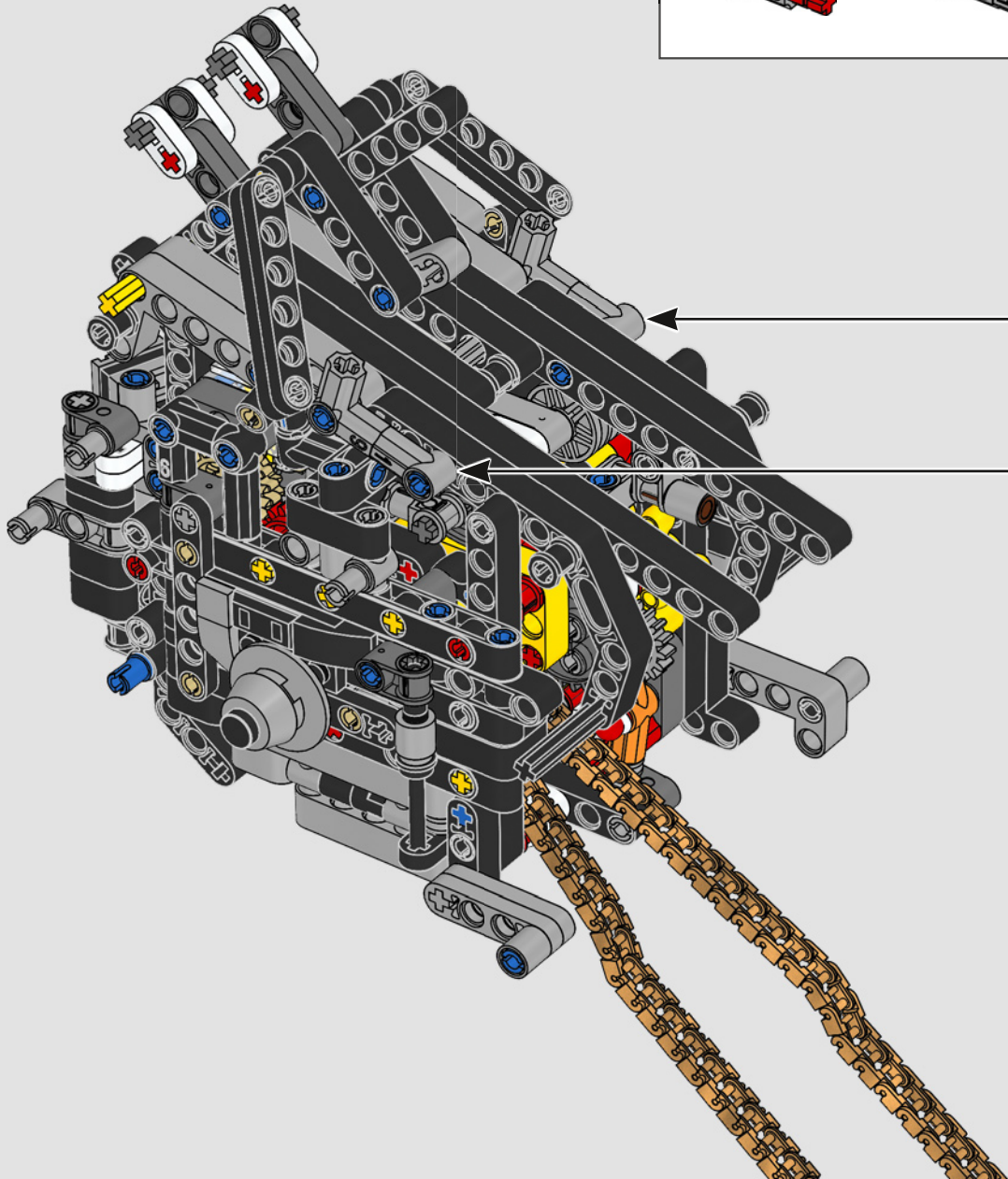
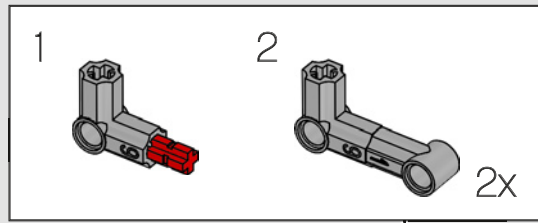

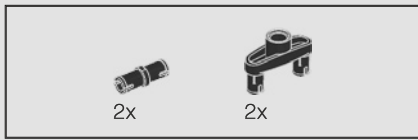

174

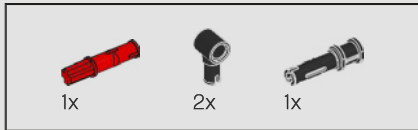
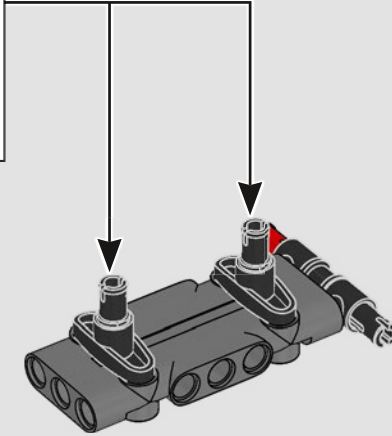
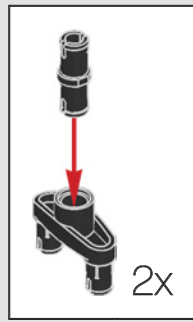

175

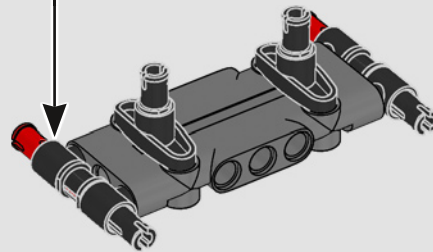
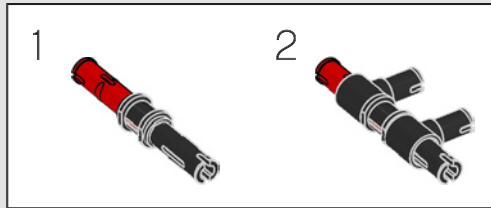

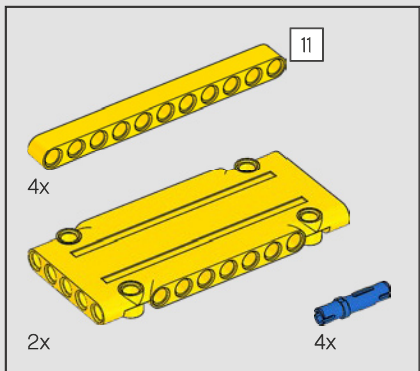

176

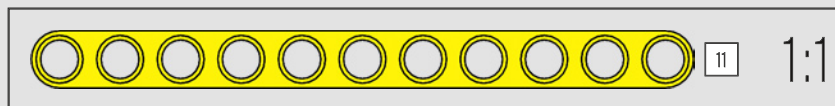
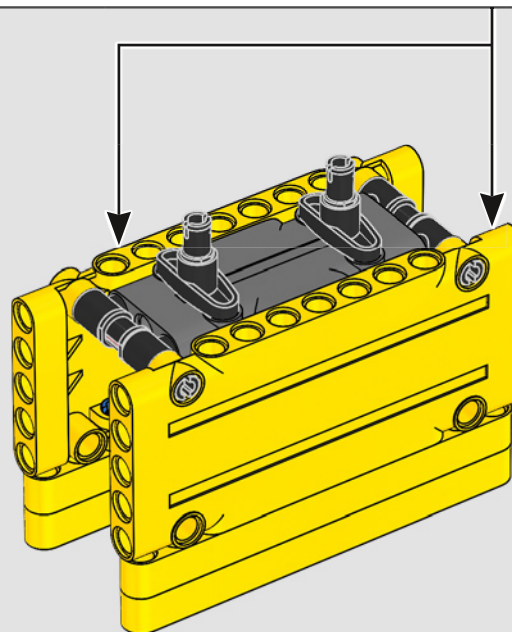
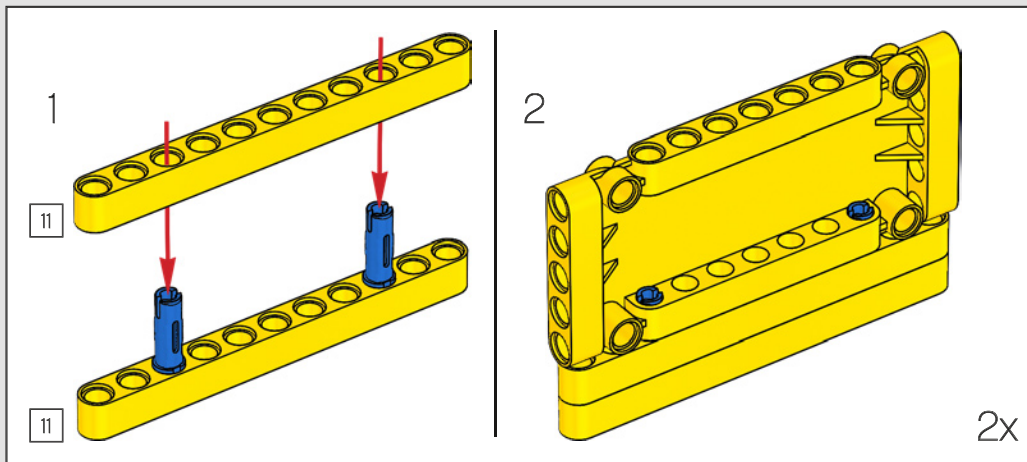

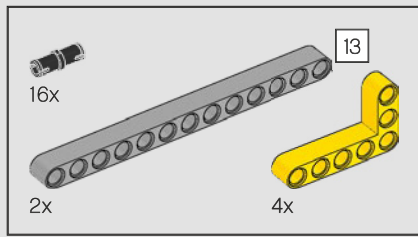

177

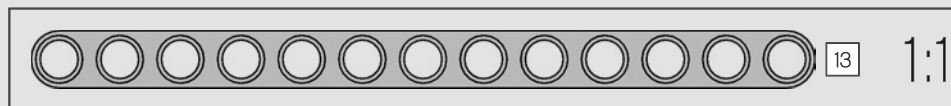
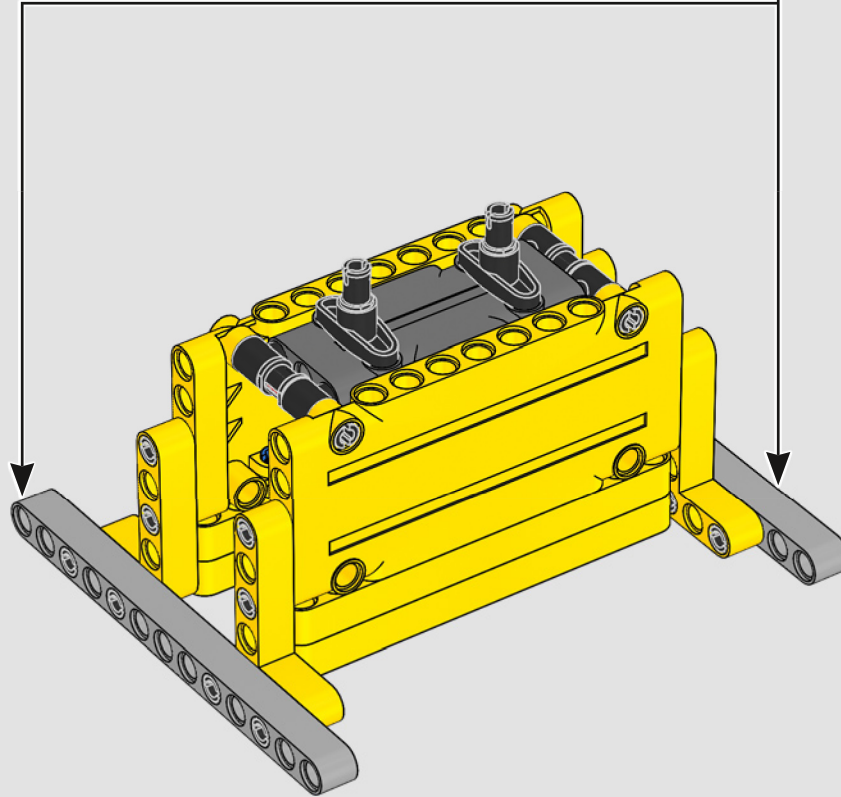
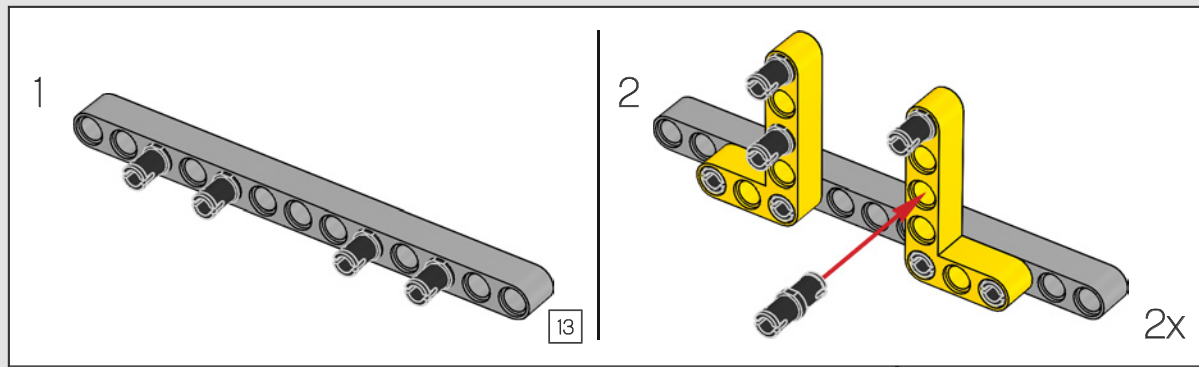

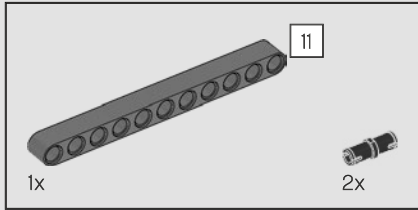
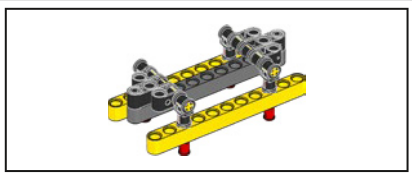

178

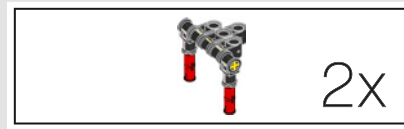
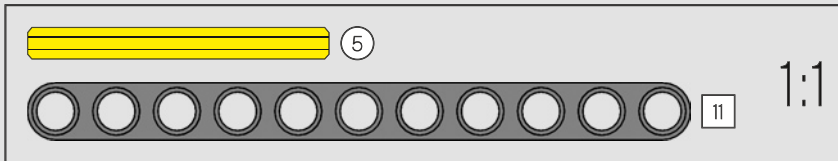
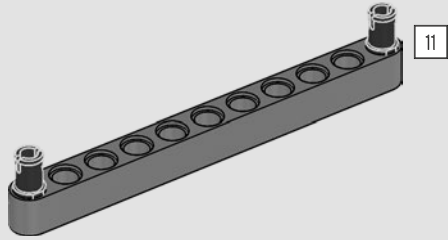

2x

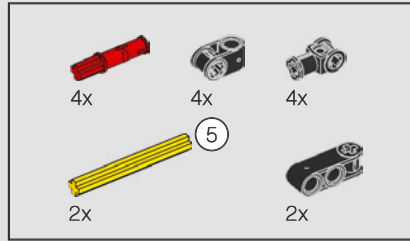

179

1

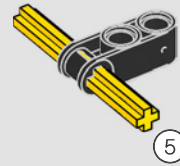

2

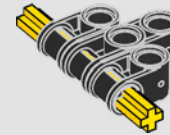

3

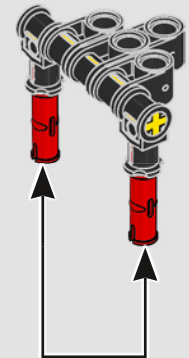

2x

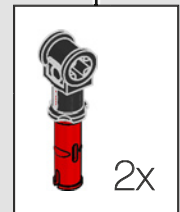

2x

180

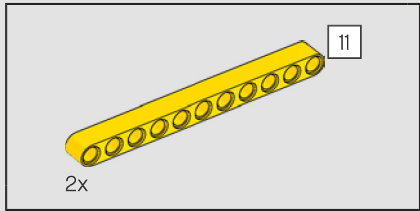
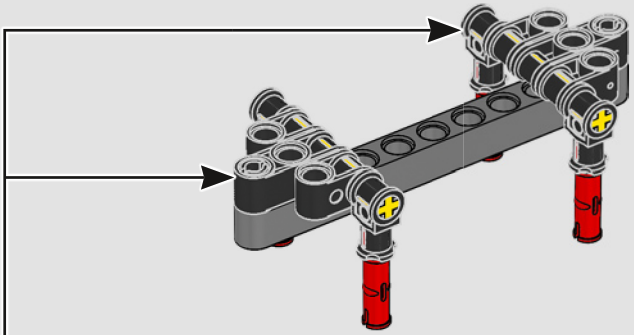

181

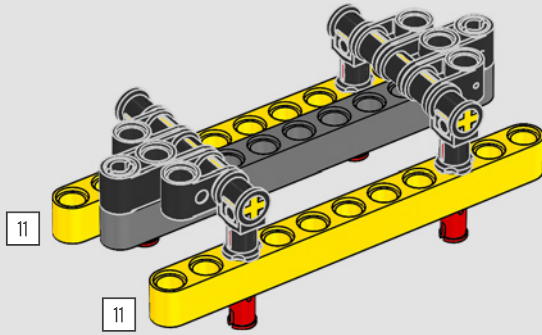

182

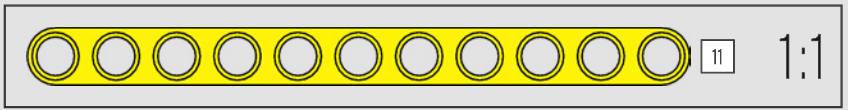
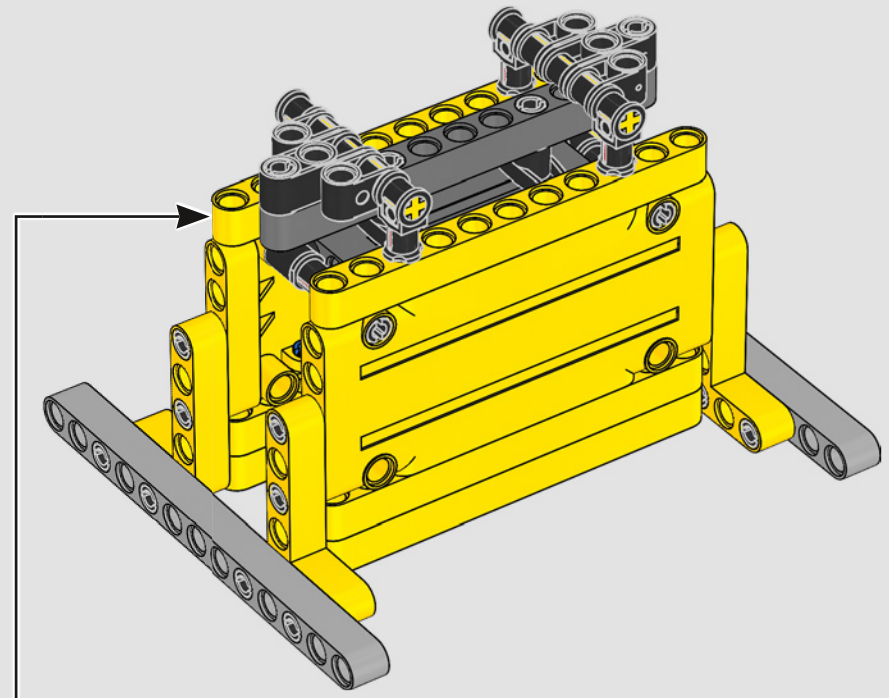

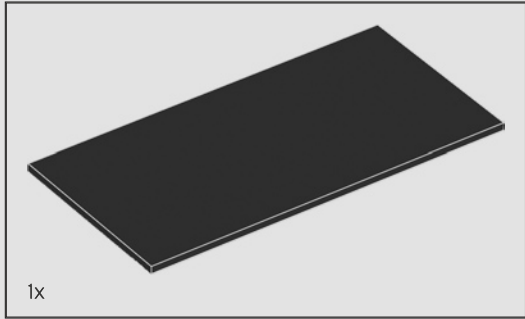
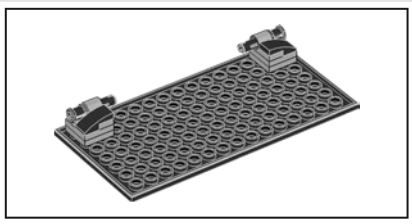

1x

183

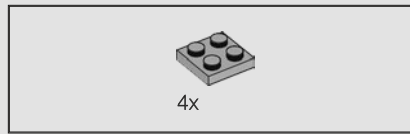
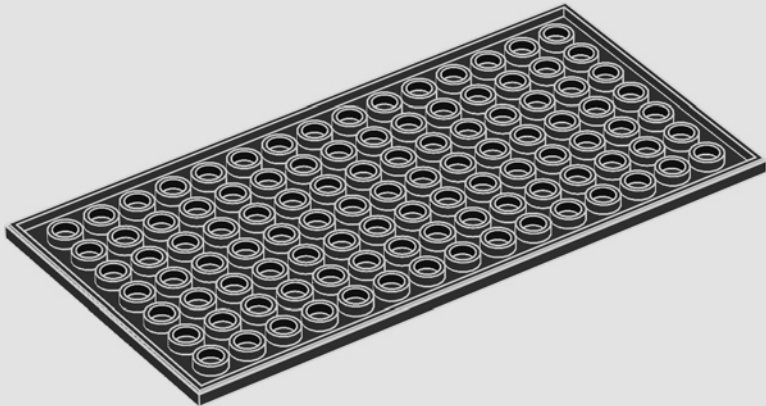

4x

184

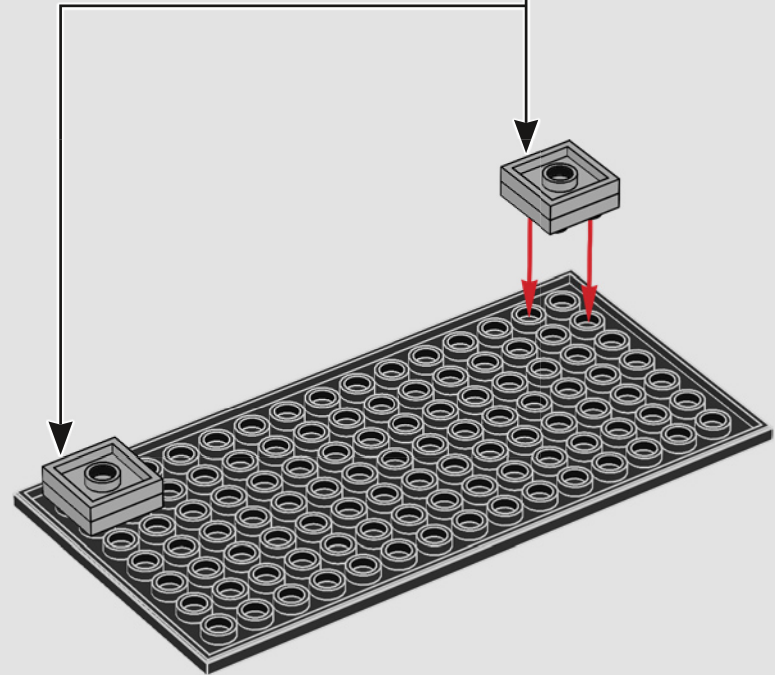
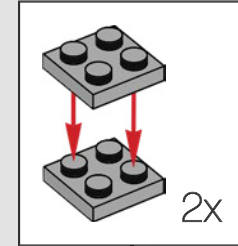

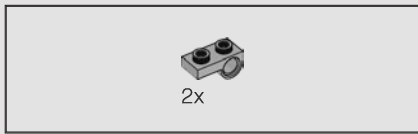

185

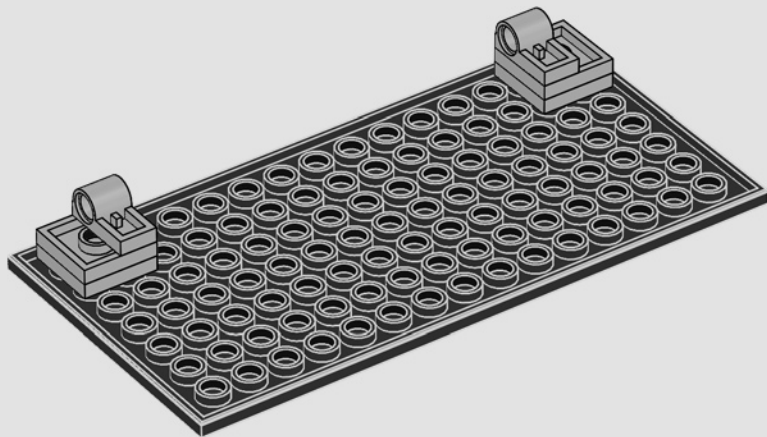

186

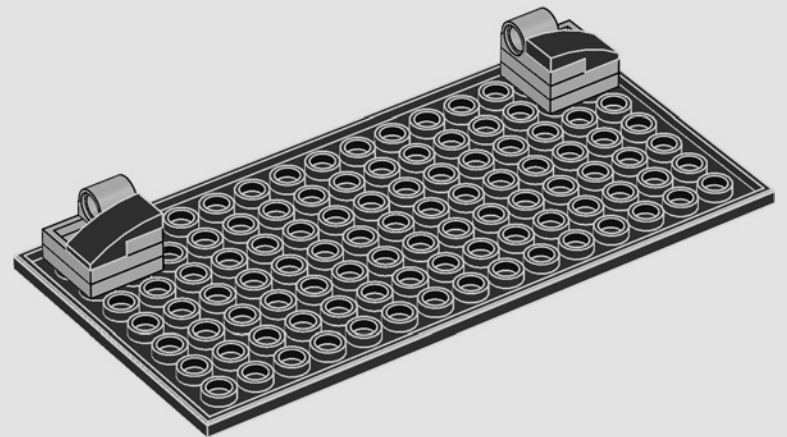



187

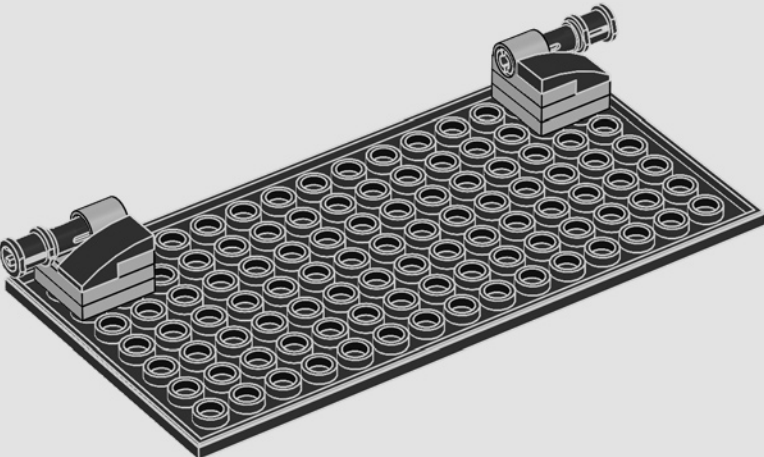

188

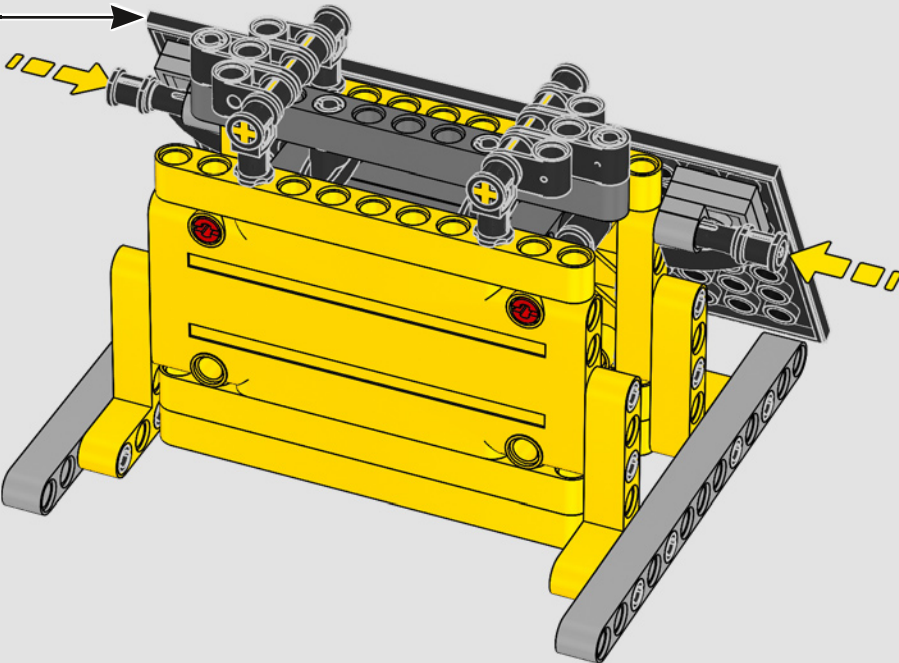

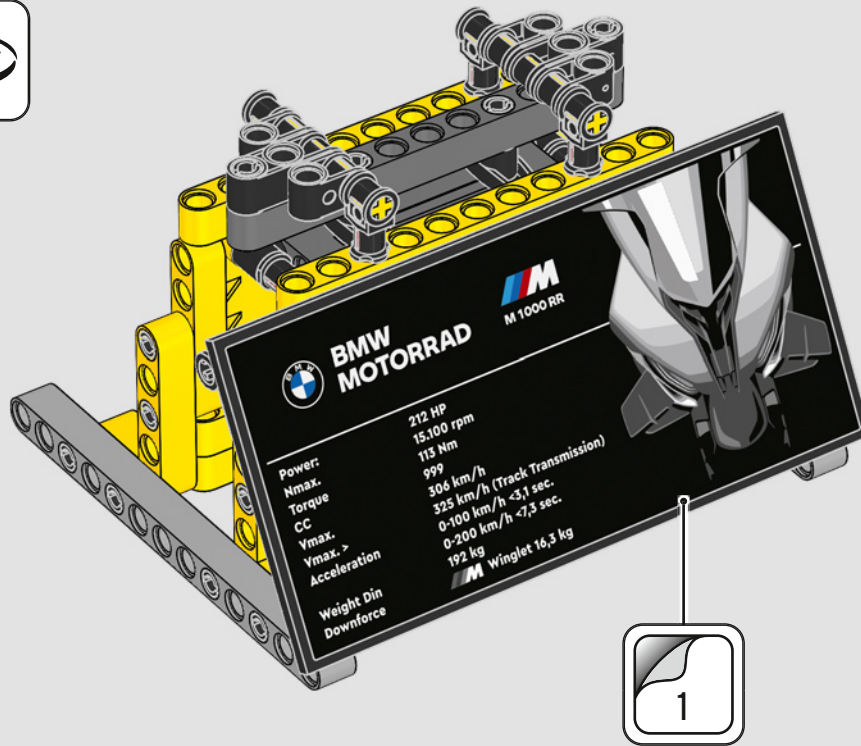

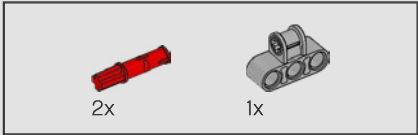
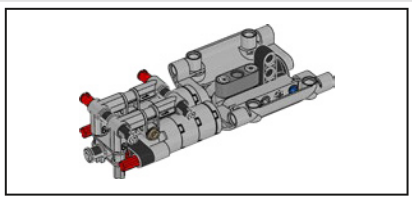

190

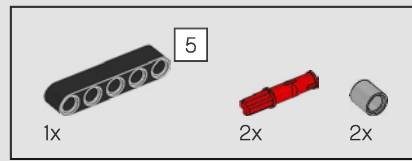
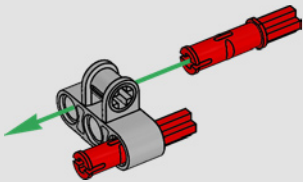

191

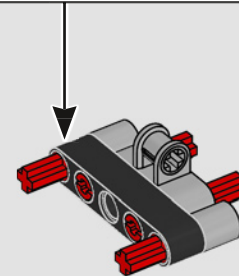
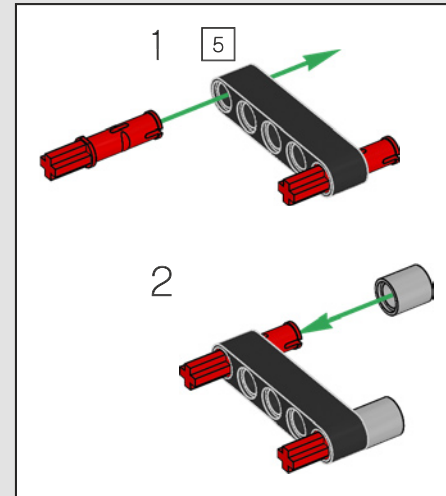

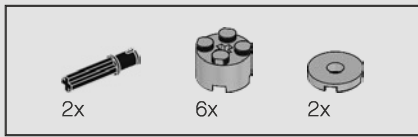

192

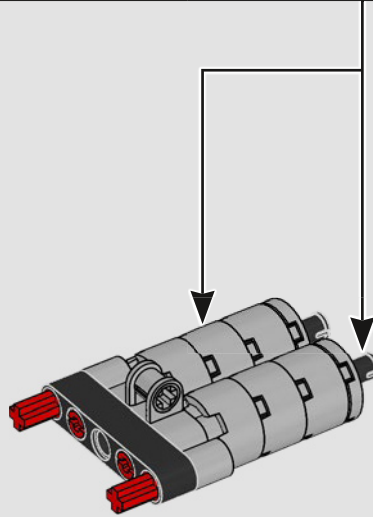
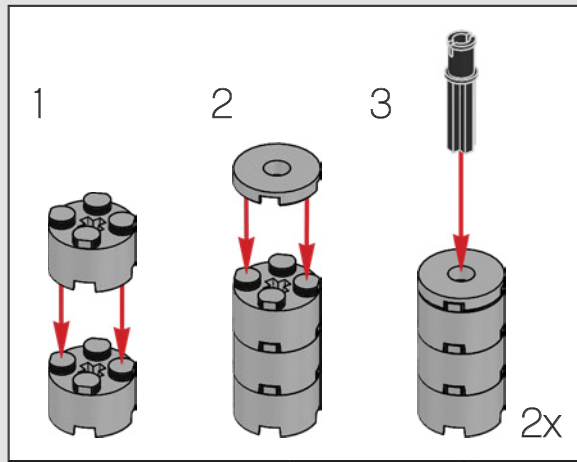

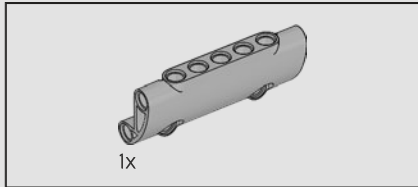
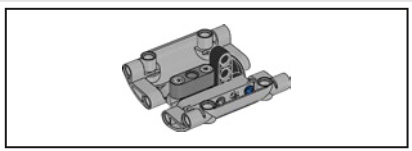

193

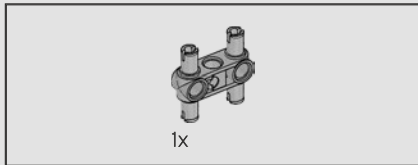
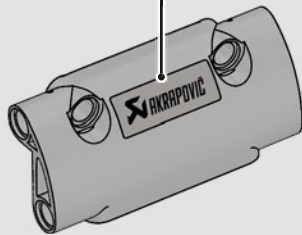

194

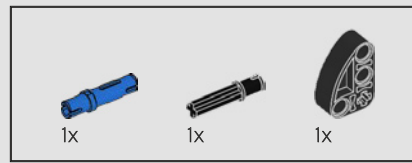
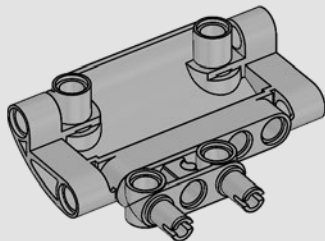

195

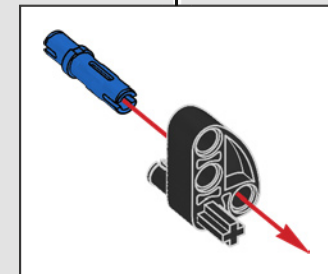
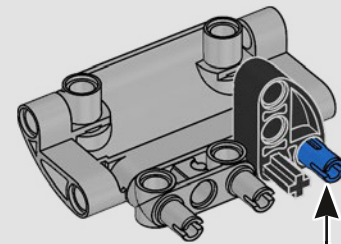

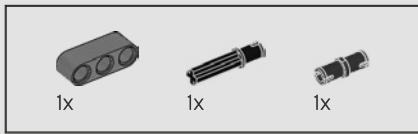

196

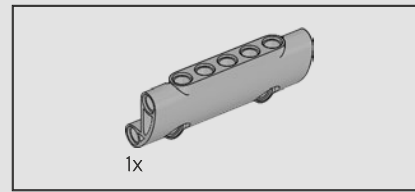
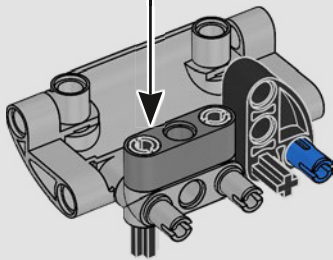
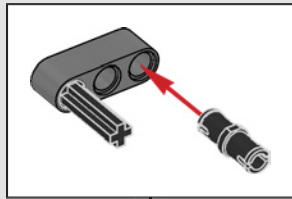

197

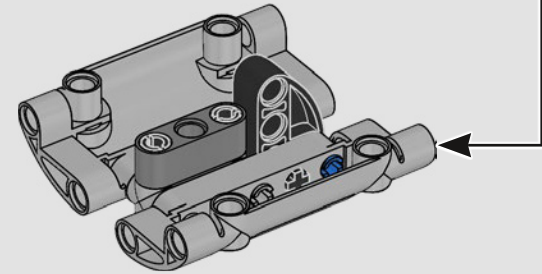
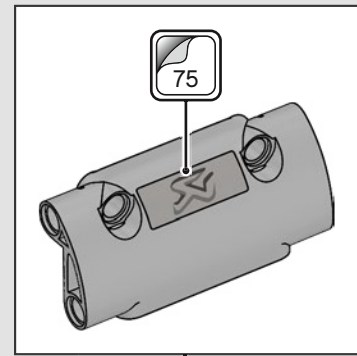

198

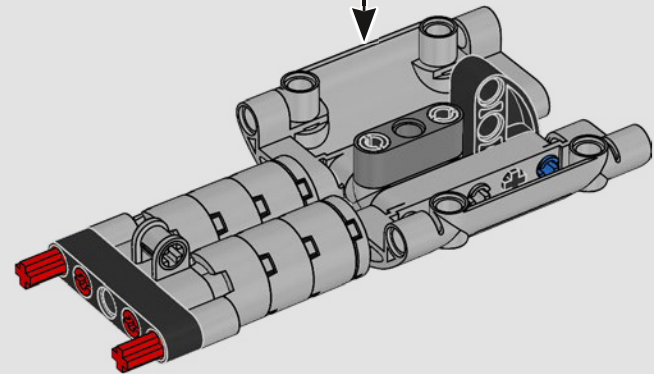

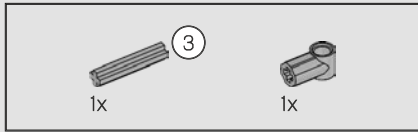
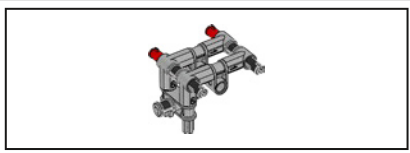

199

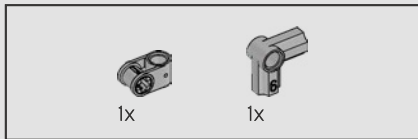
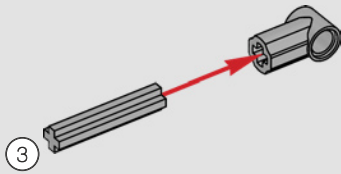

200

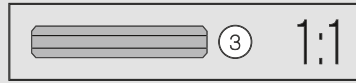
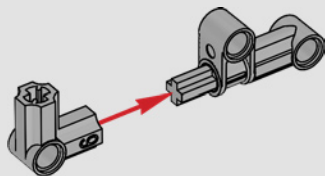

201

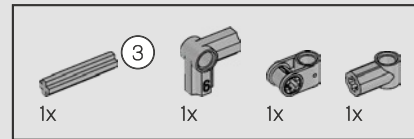
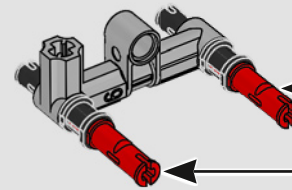
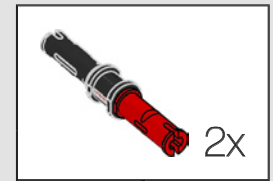

202

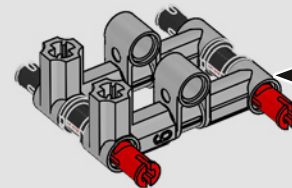
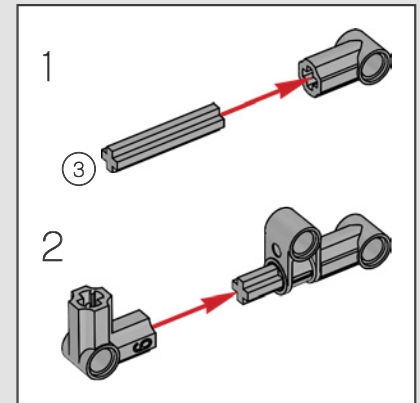

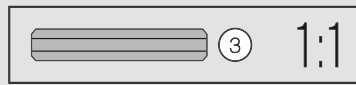
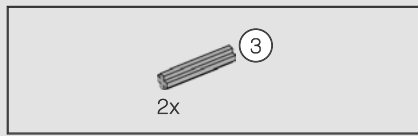

203

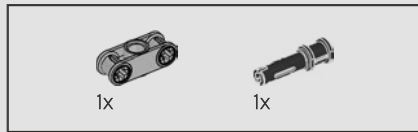
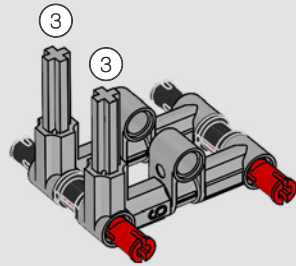

204

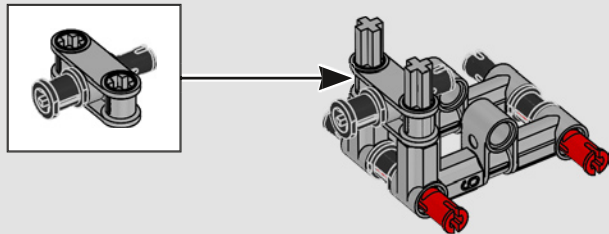

205

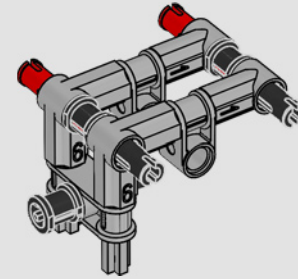

206

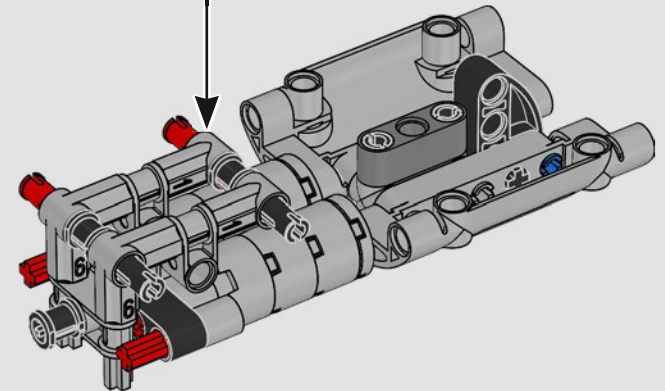

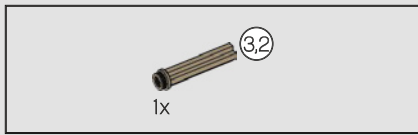

207

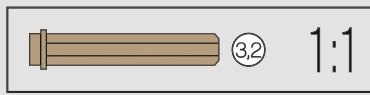
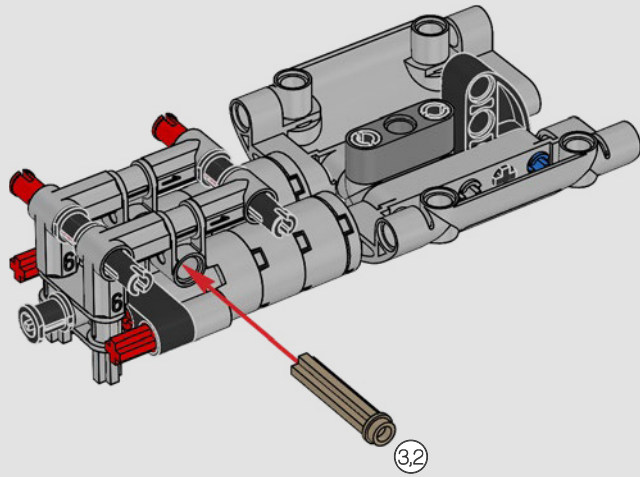

208

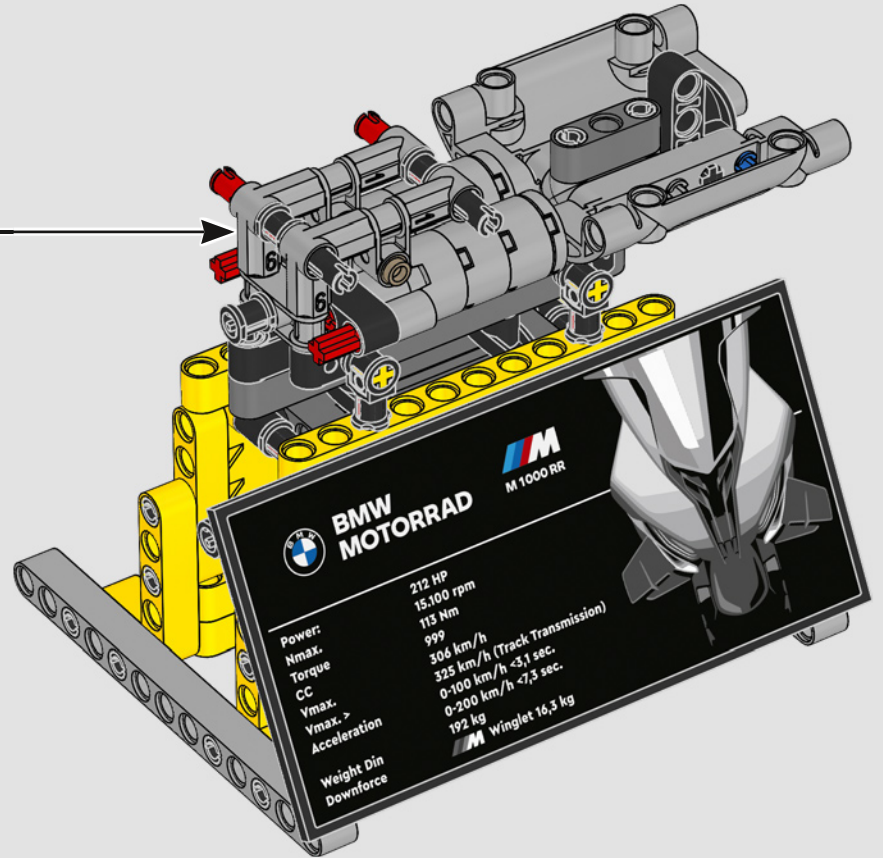

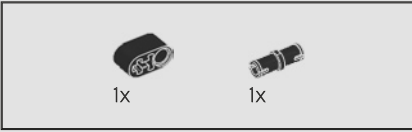
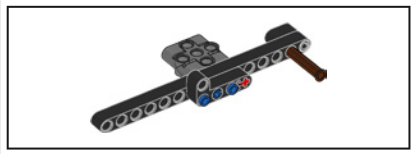

209

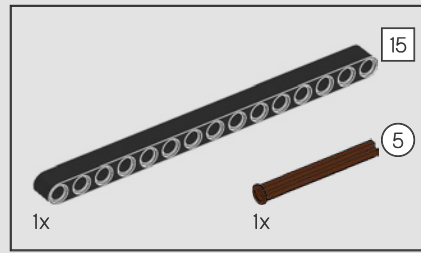
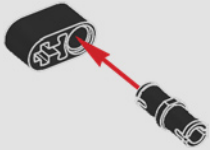

210

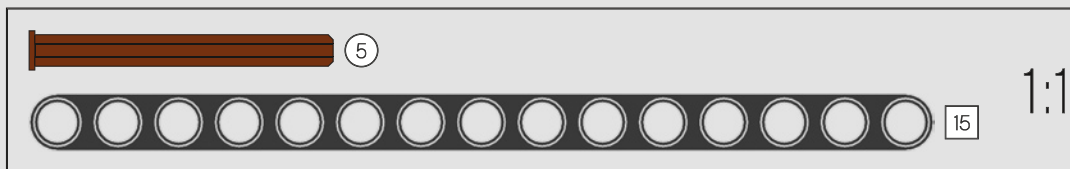
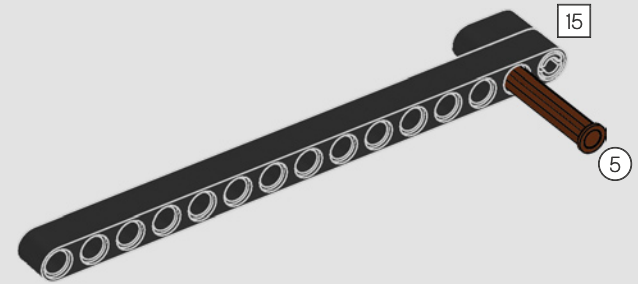

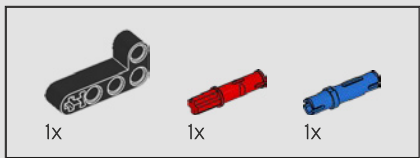

211

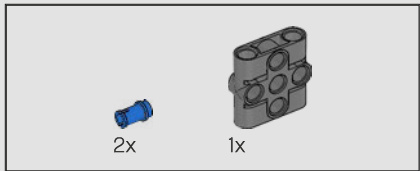
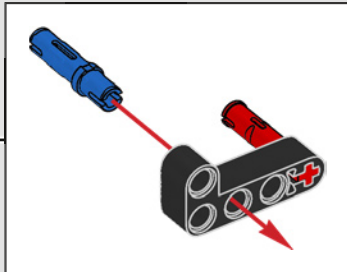
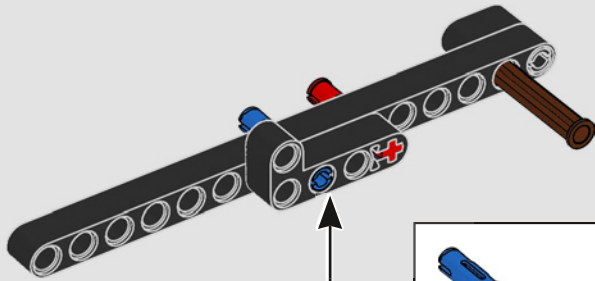

212

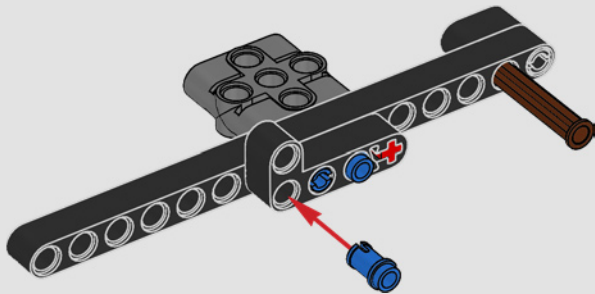

213

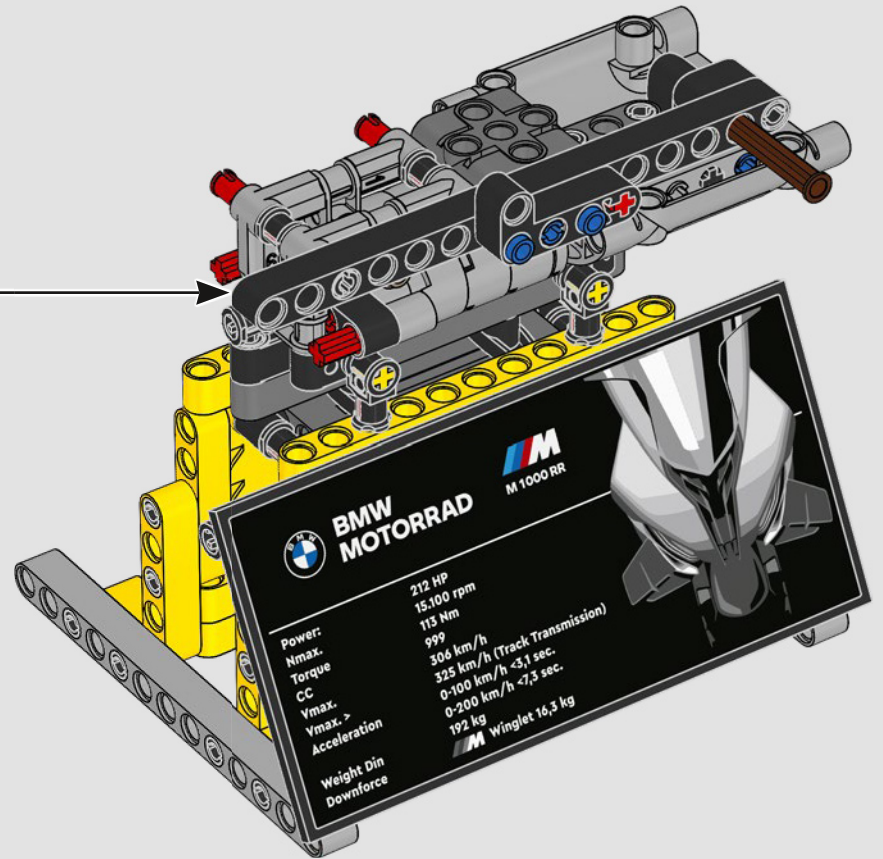

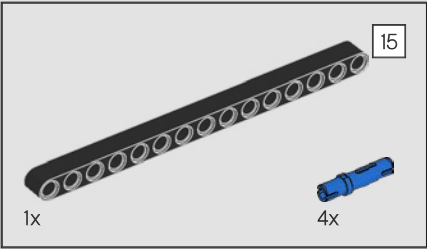
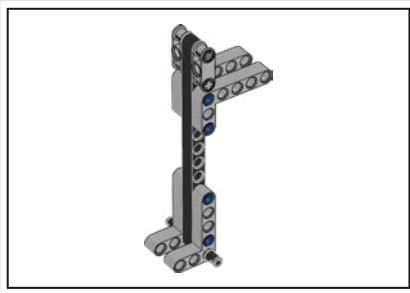

214

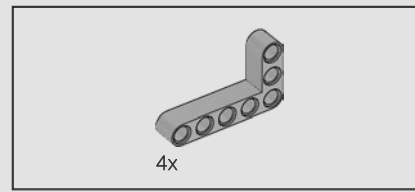
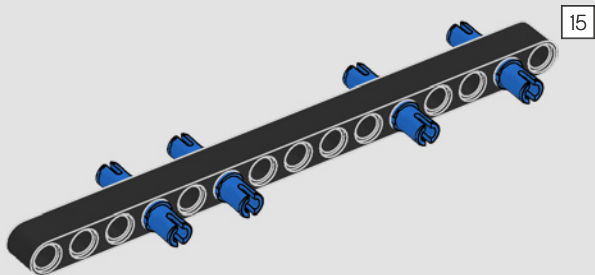

215

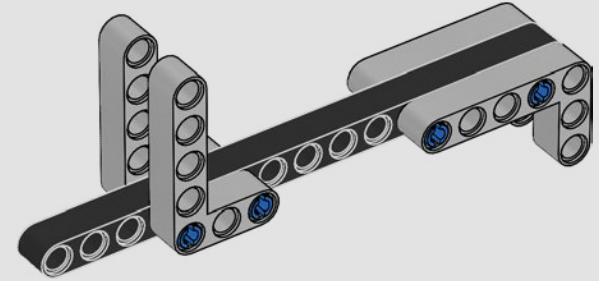

216

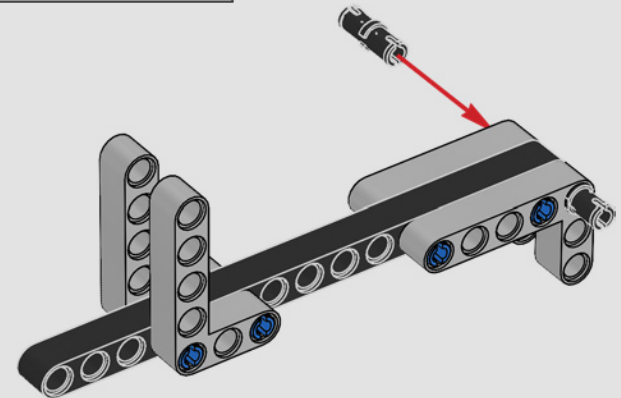

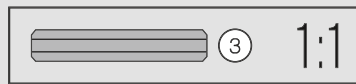
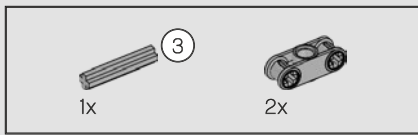

217

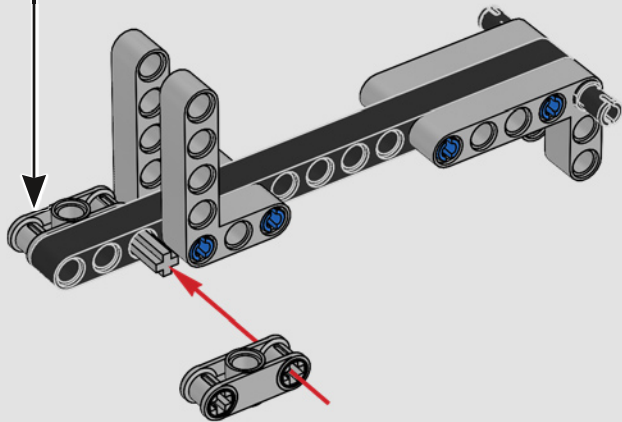
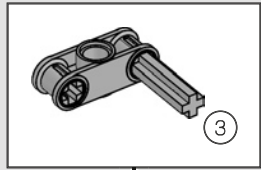

218

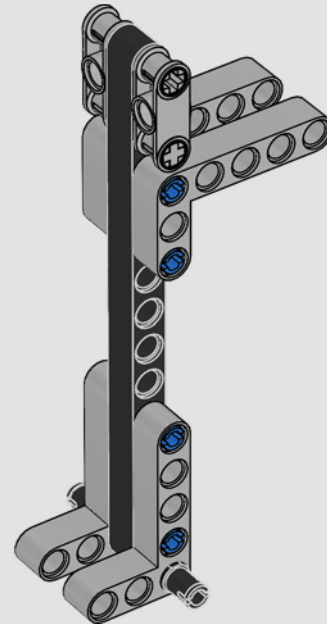
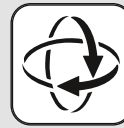

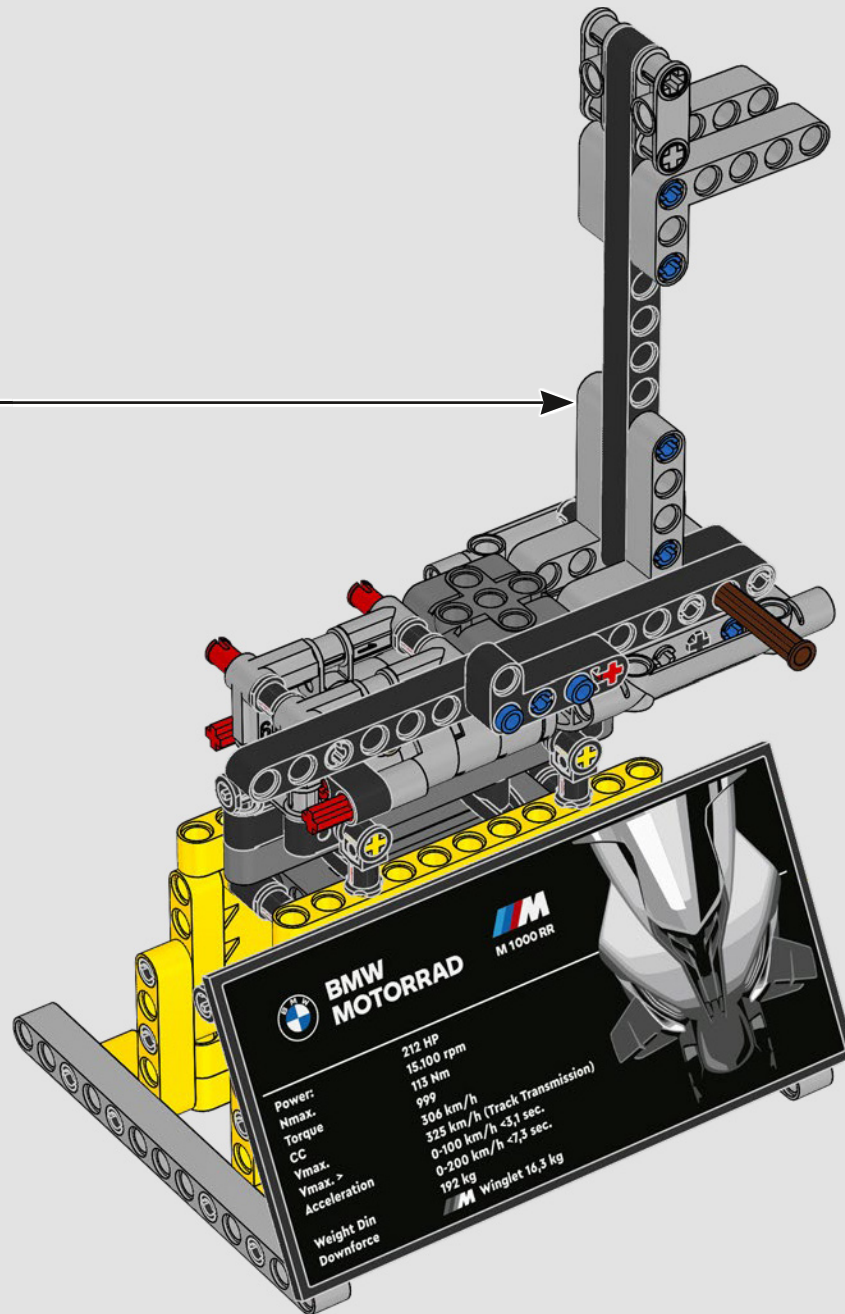

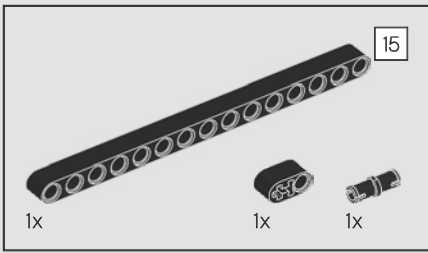

220

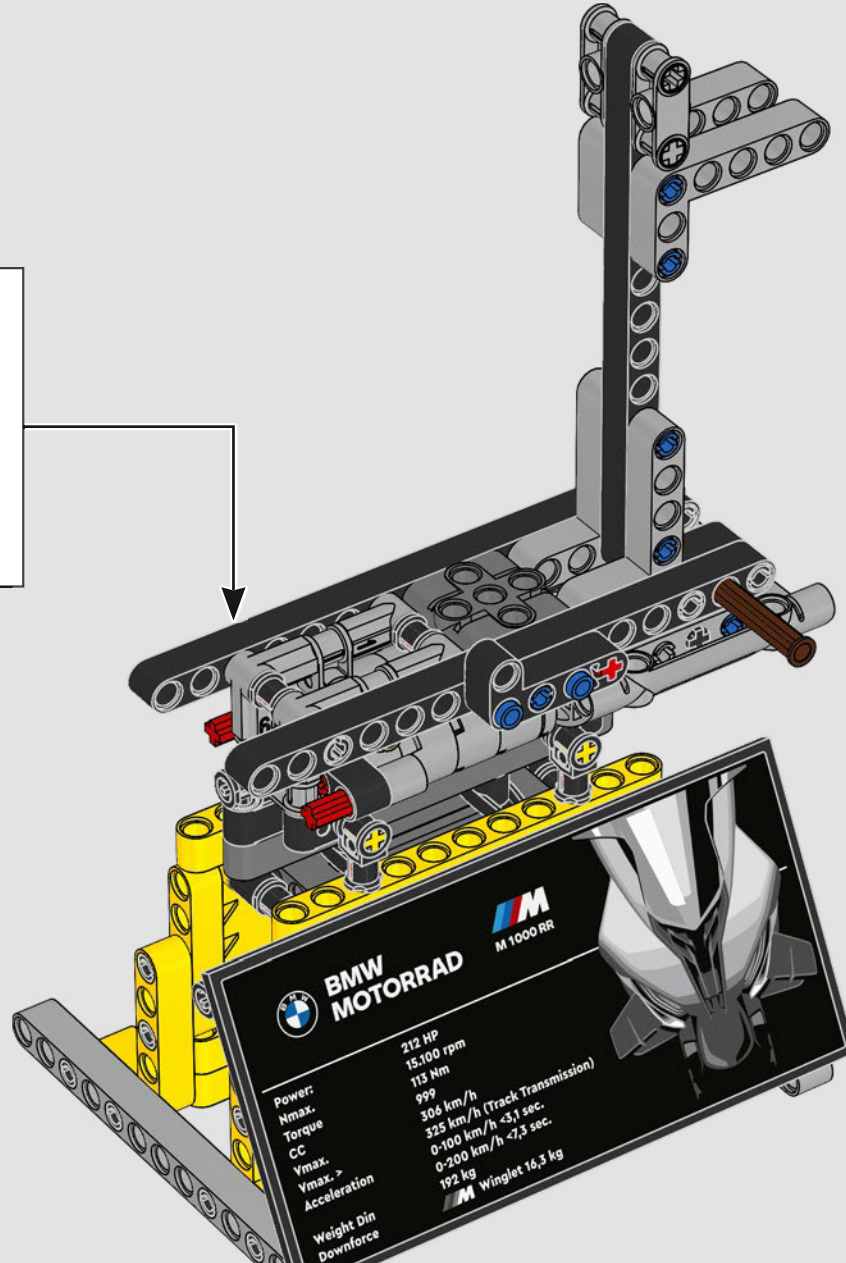
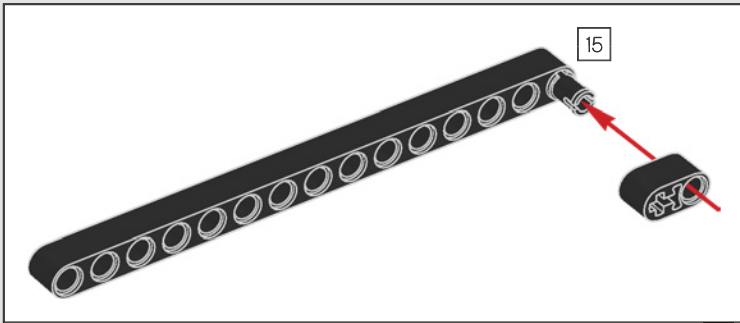

221

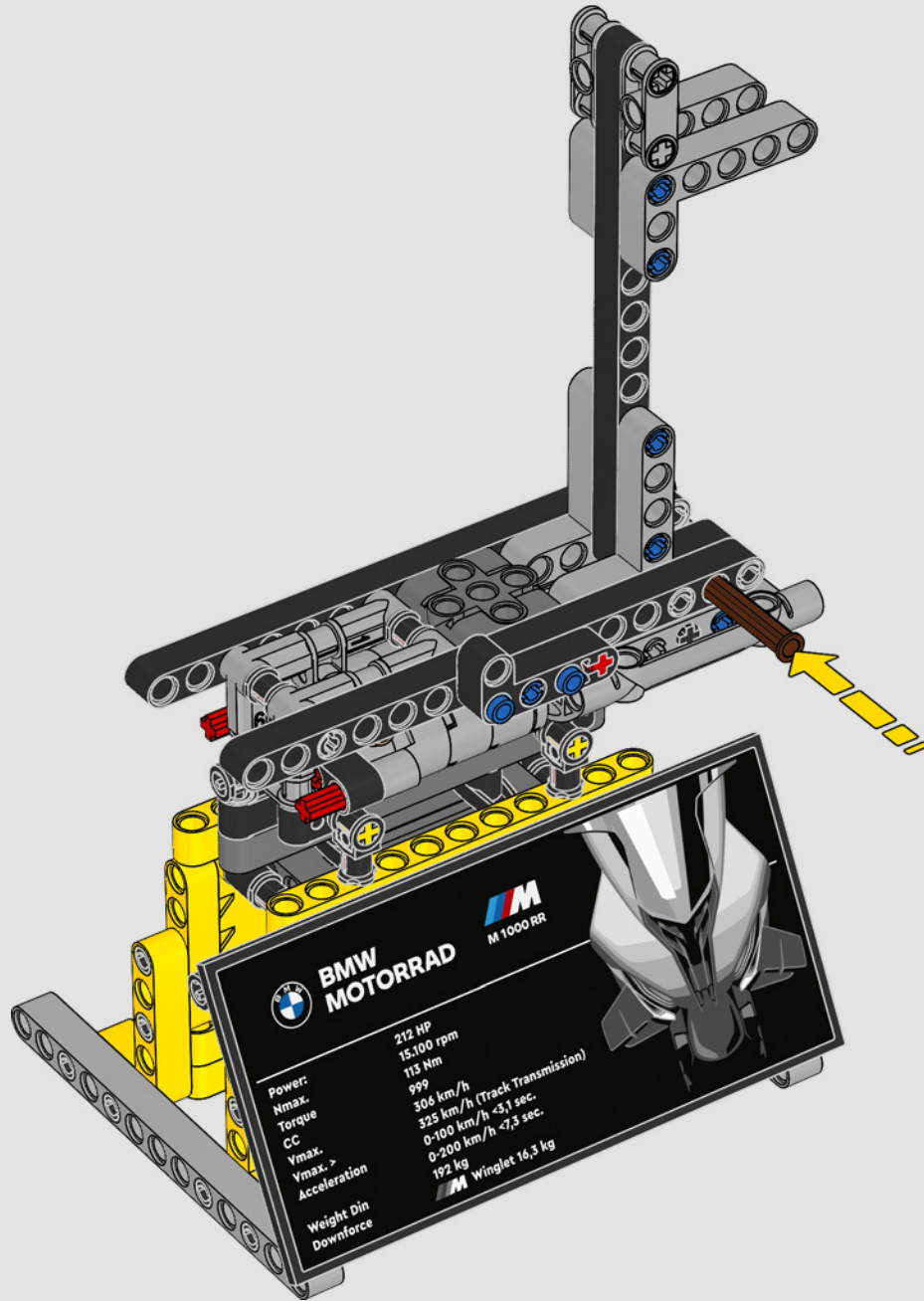

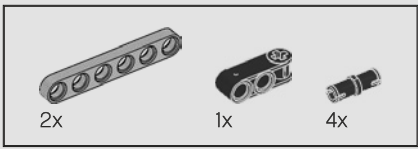

222

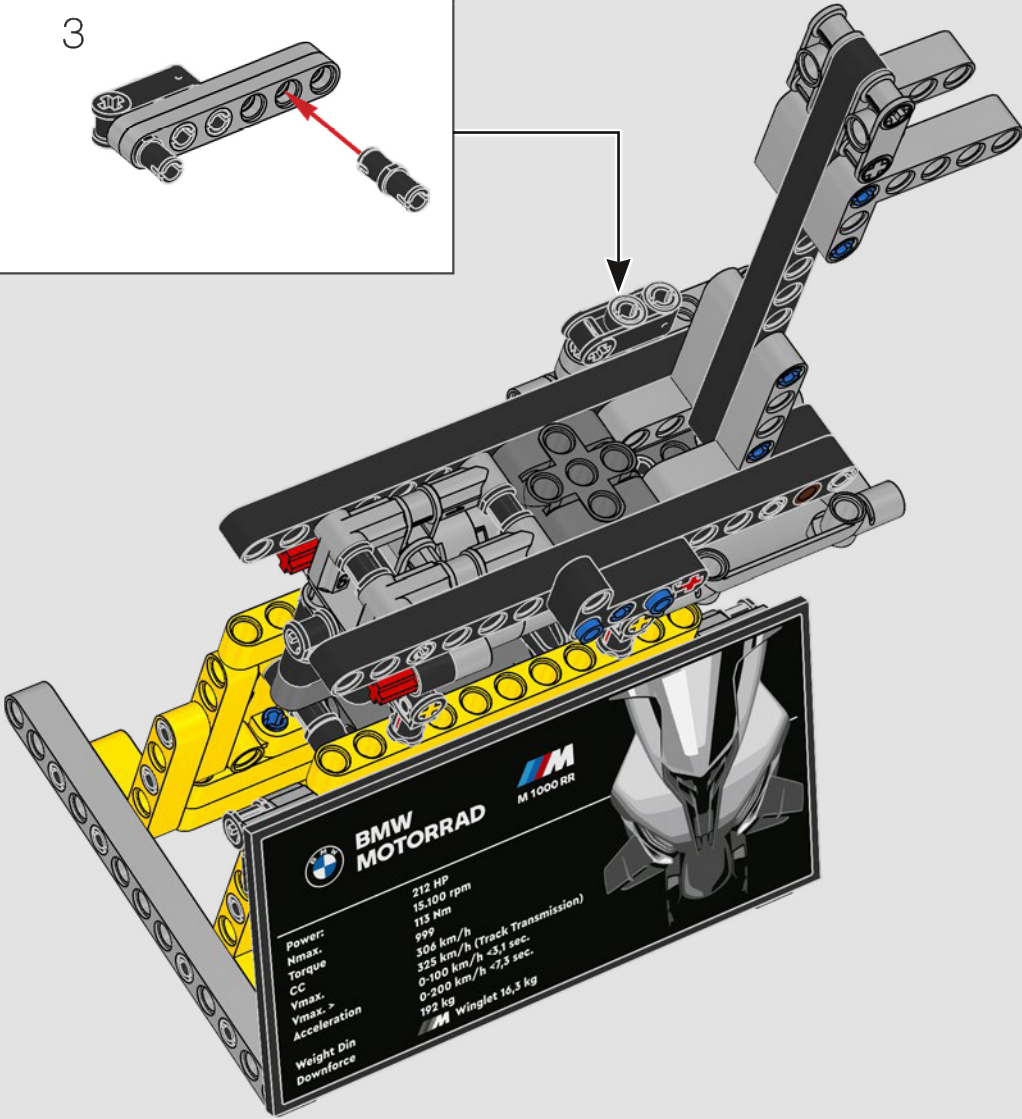
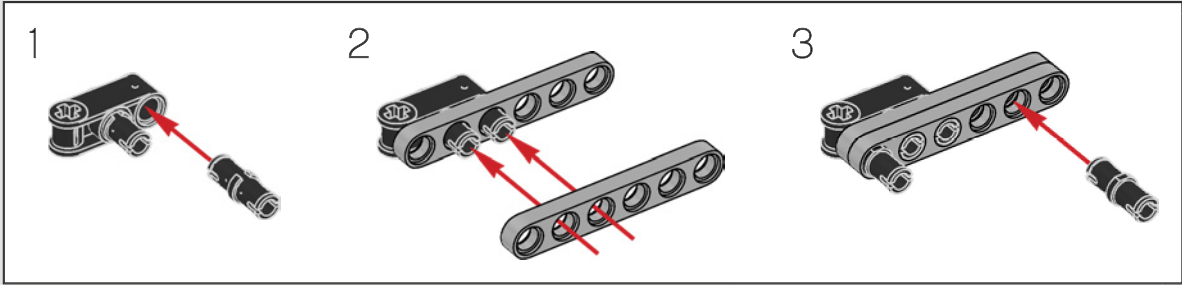

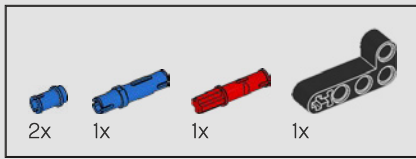

223

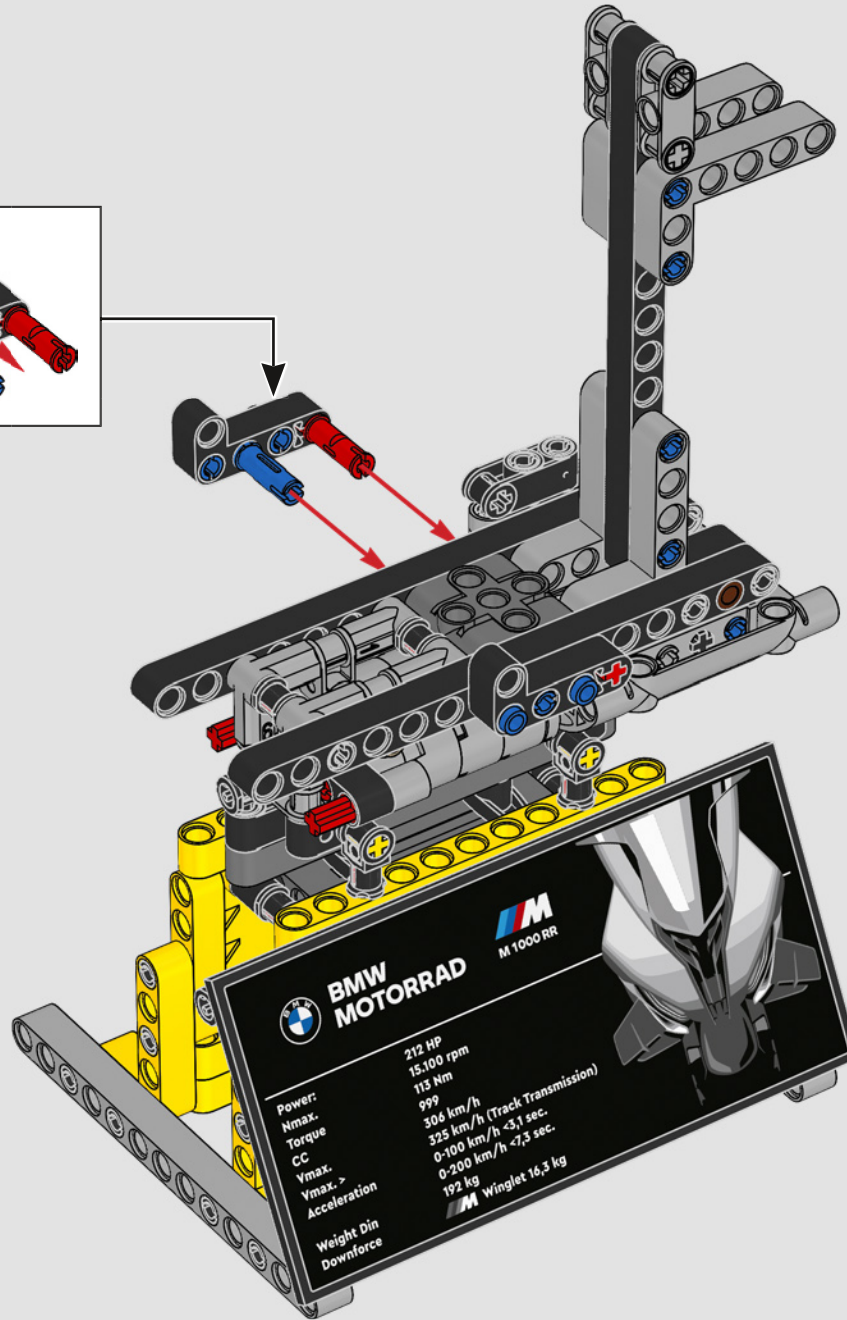
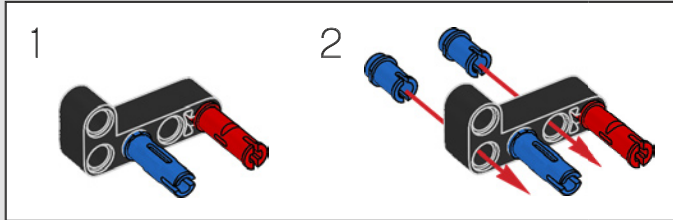

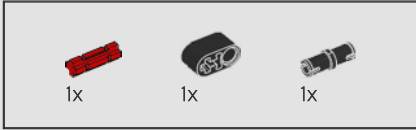
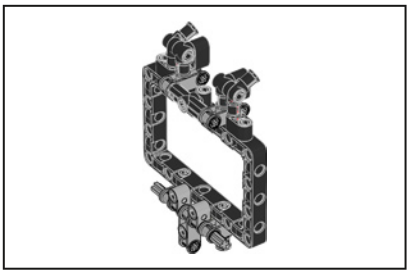

224

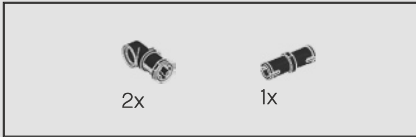
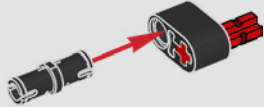

225

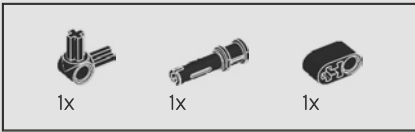
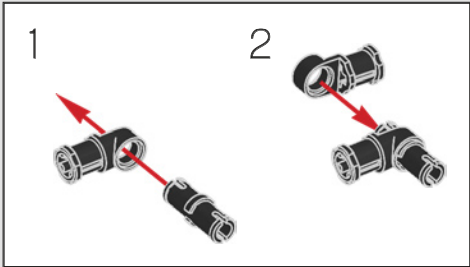

226

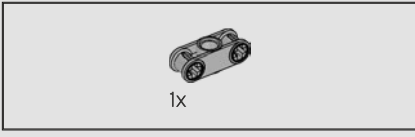
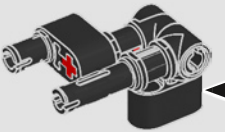
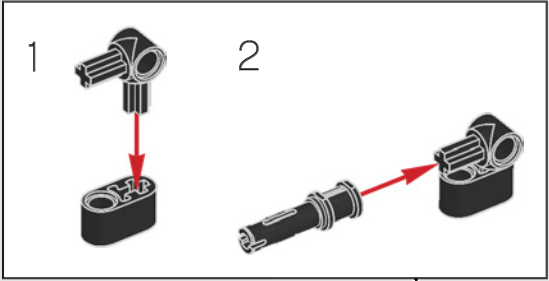

227

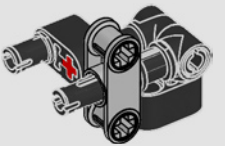

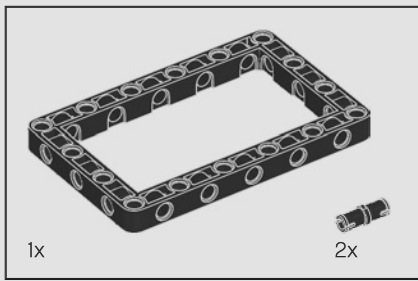

228

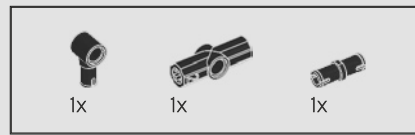
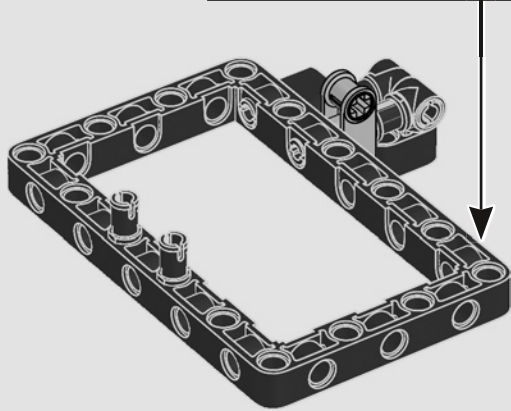
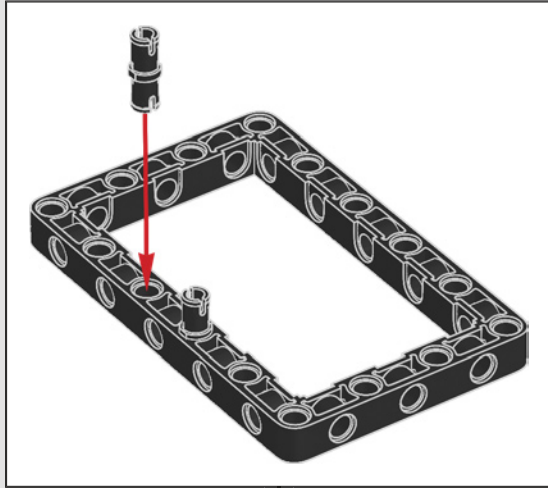

229

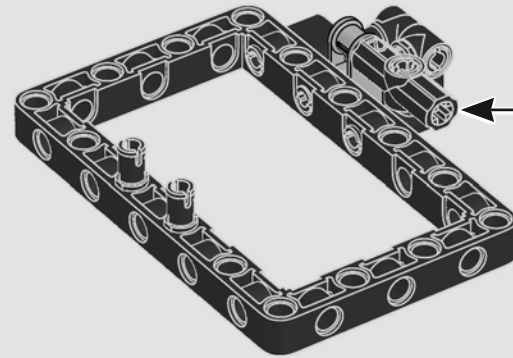
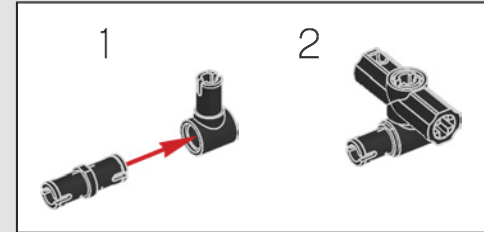



230

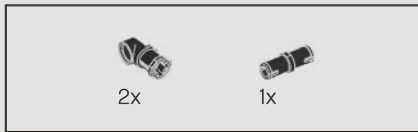

231

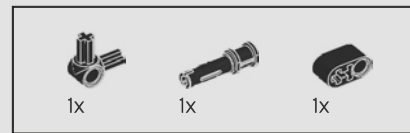
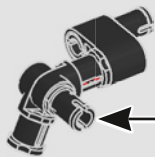
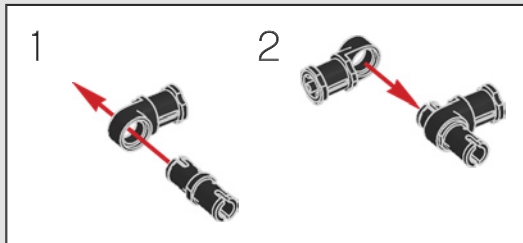

232

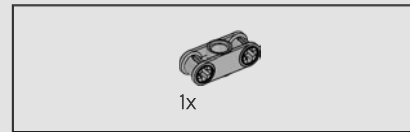
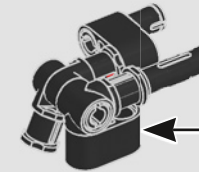
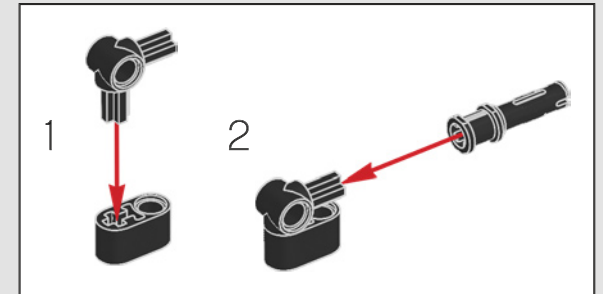

233

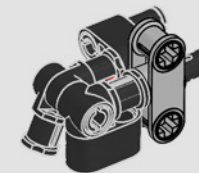

234

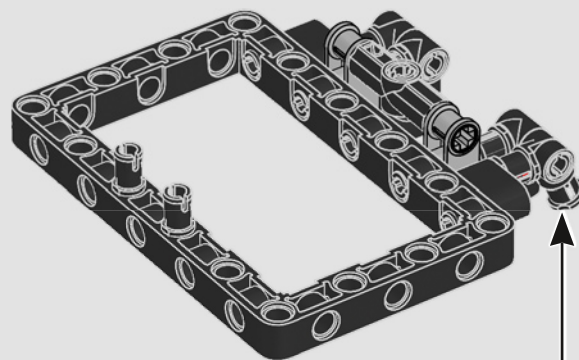

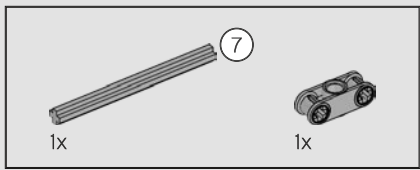

235

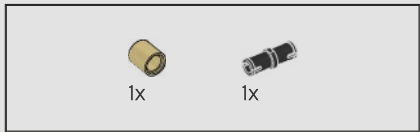
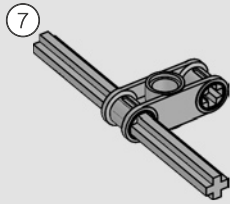

236

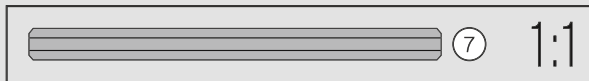
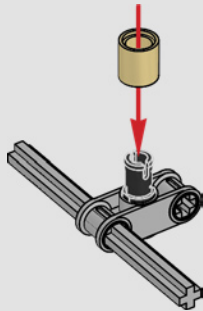

237

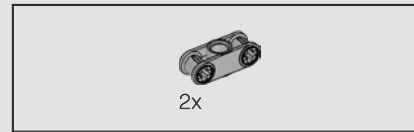
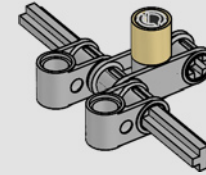

238

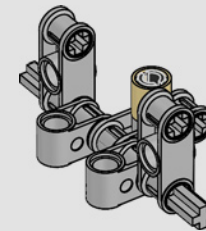

239

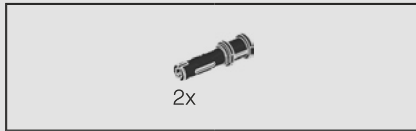
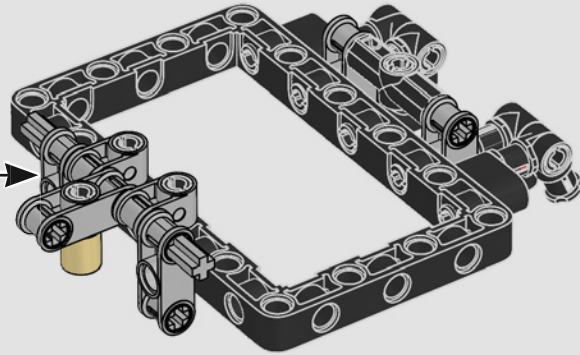

240

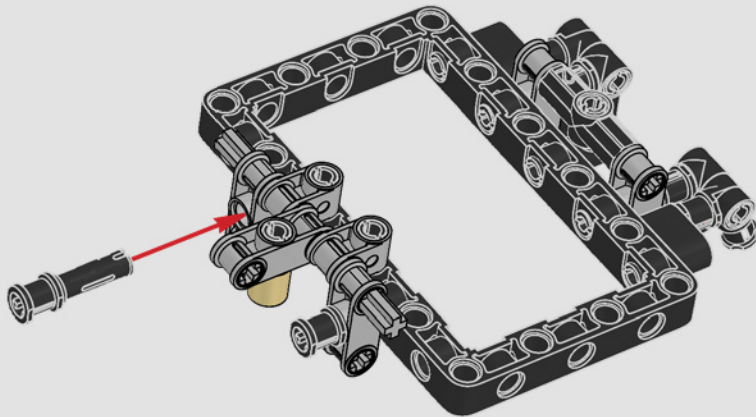

241

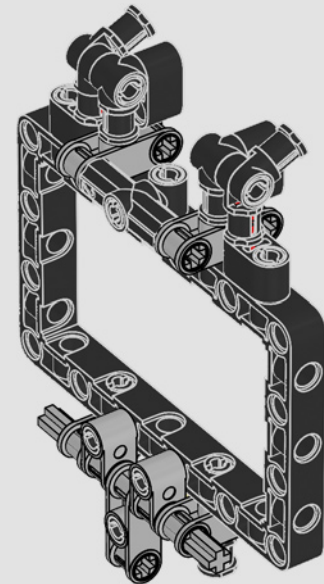

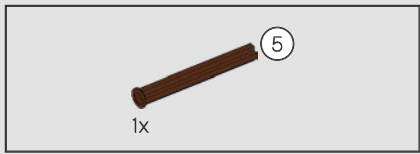

242

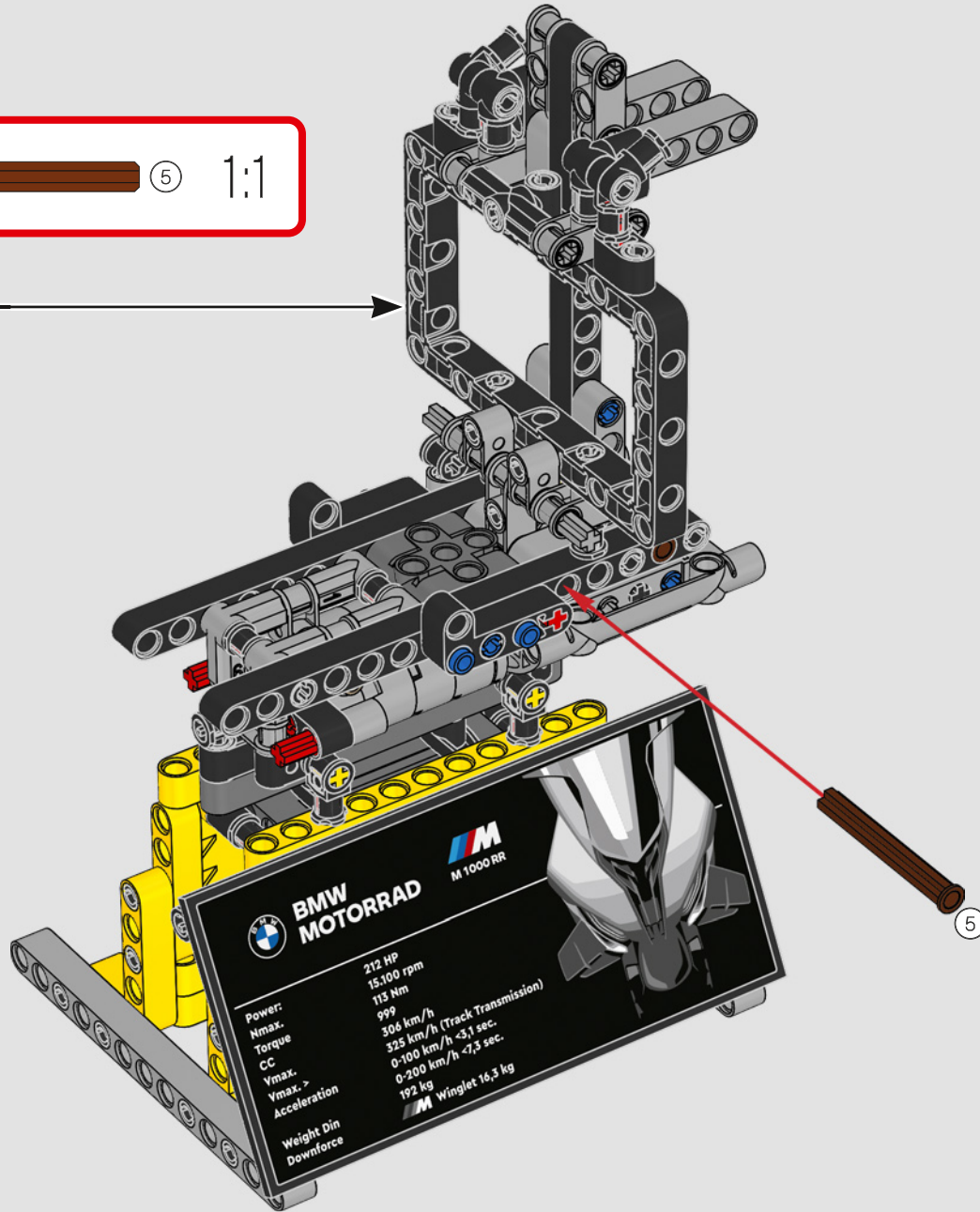

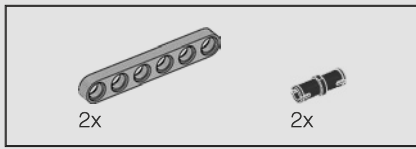

243

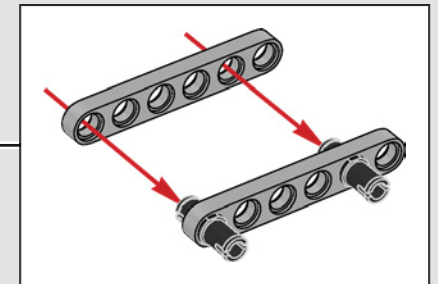
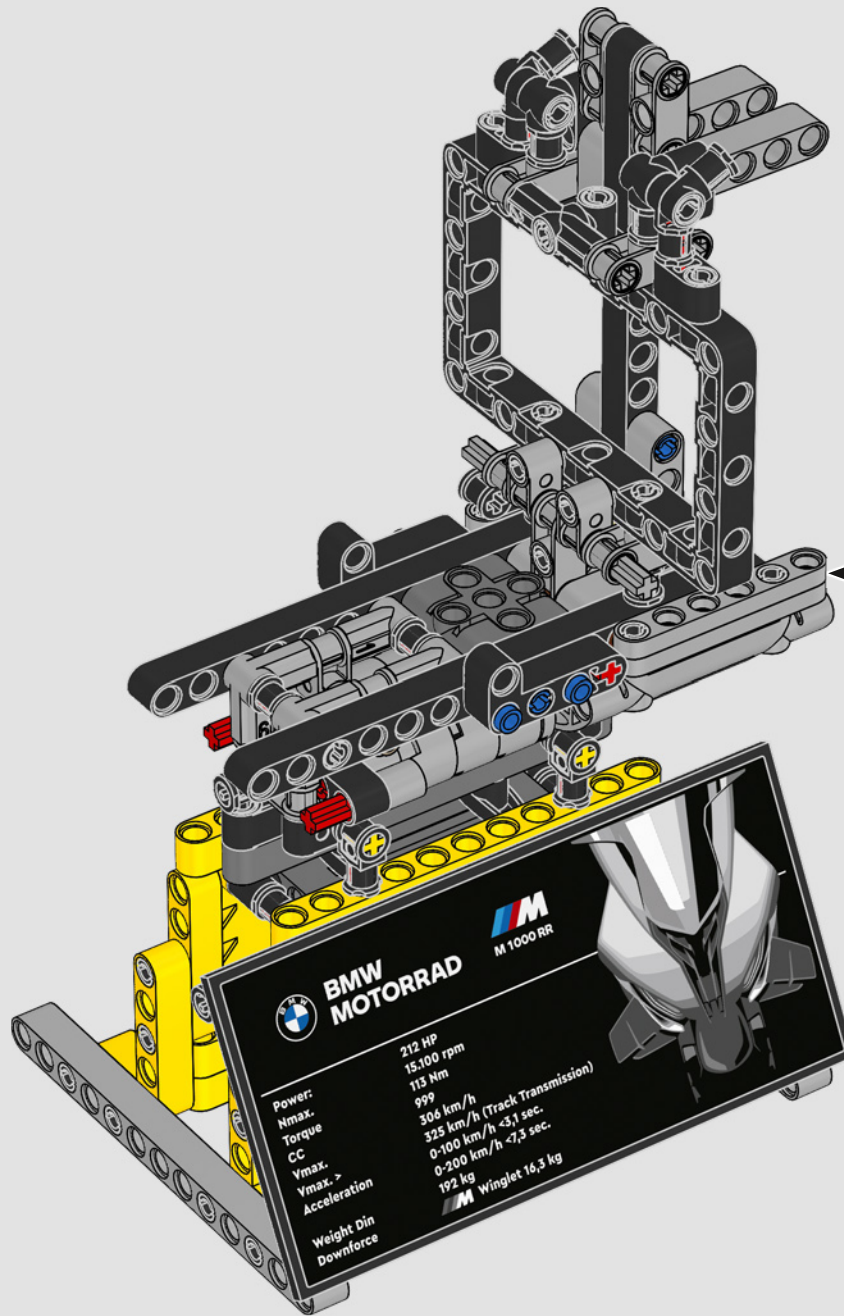

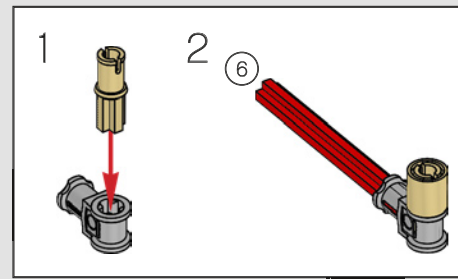
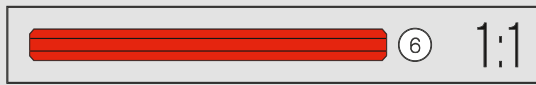
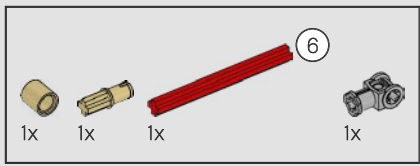

244

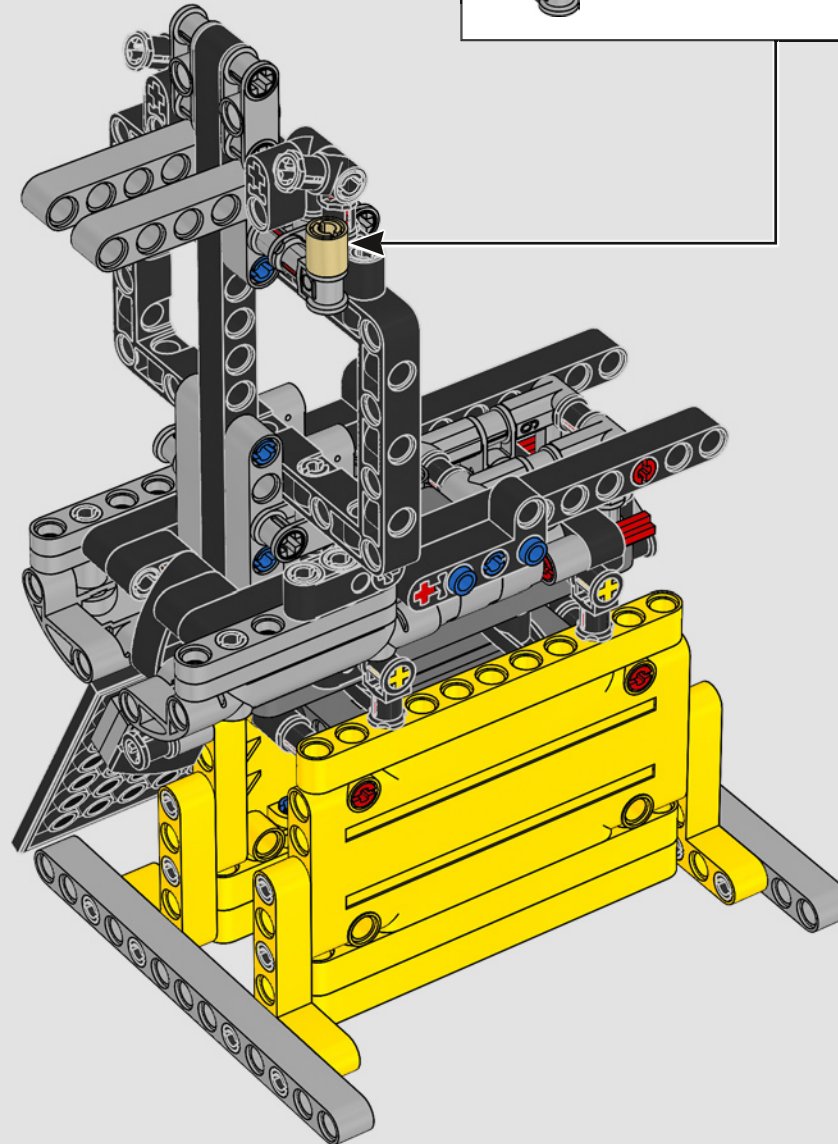

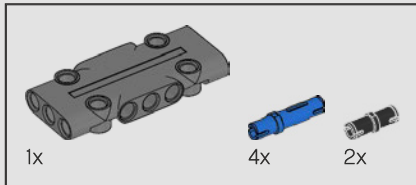
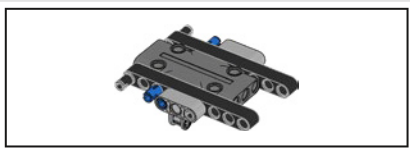

246

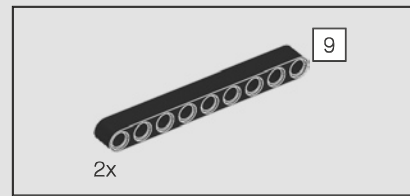
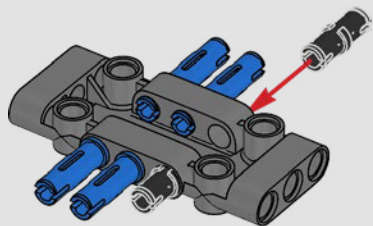

247

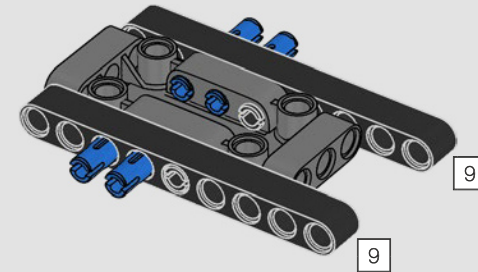

248

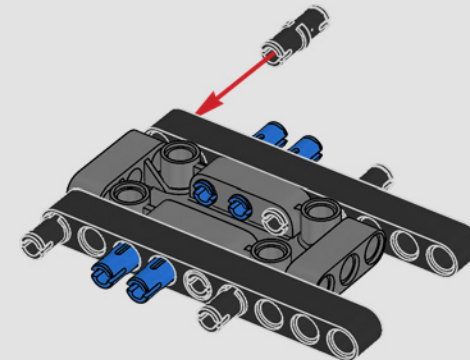

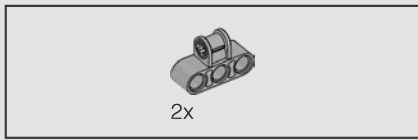

249

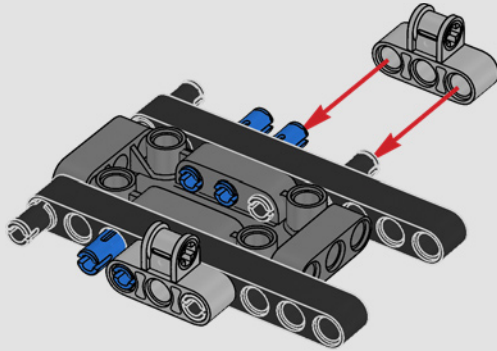

250

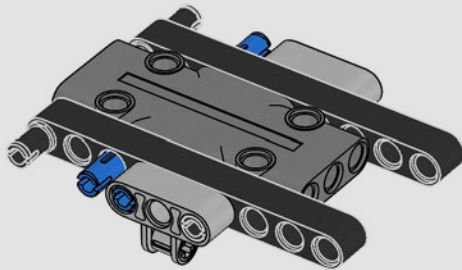

251

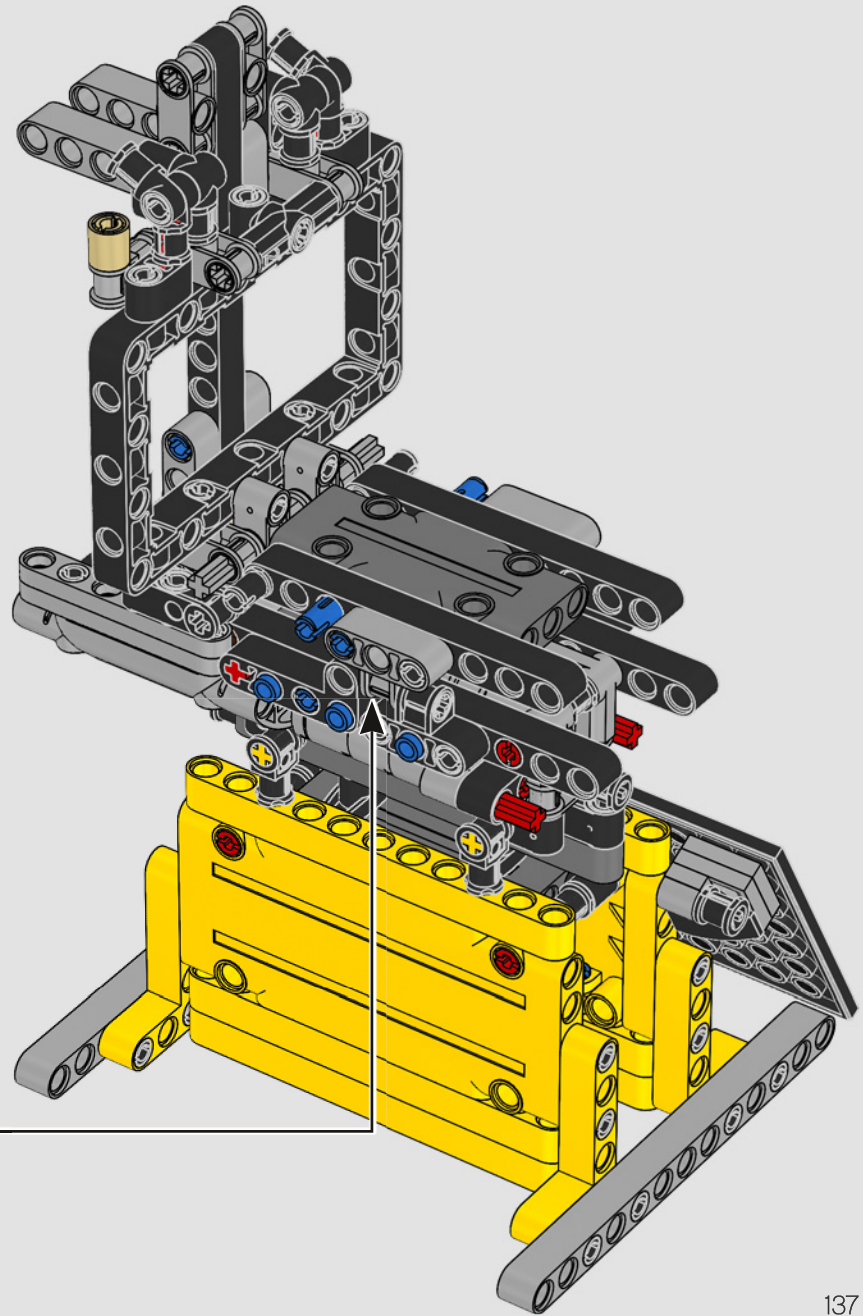

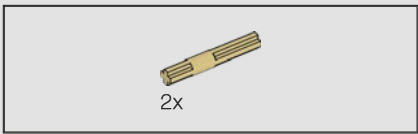

252

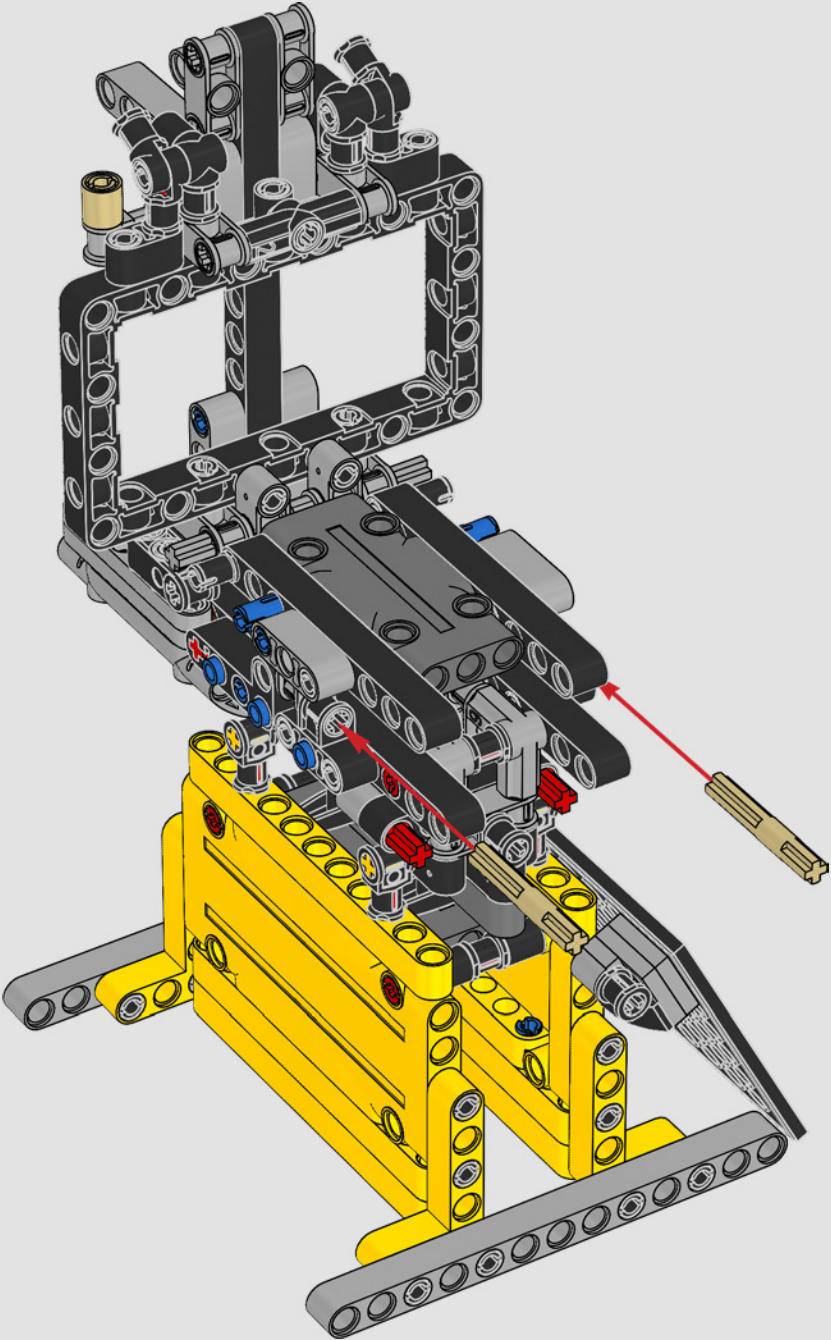

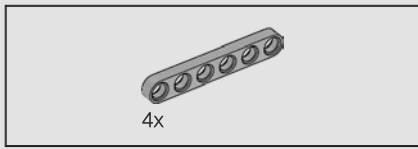

253

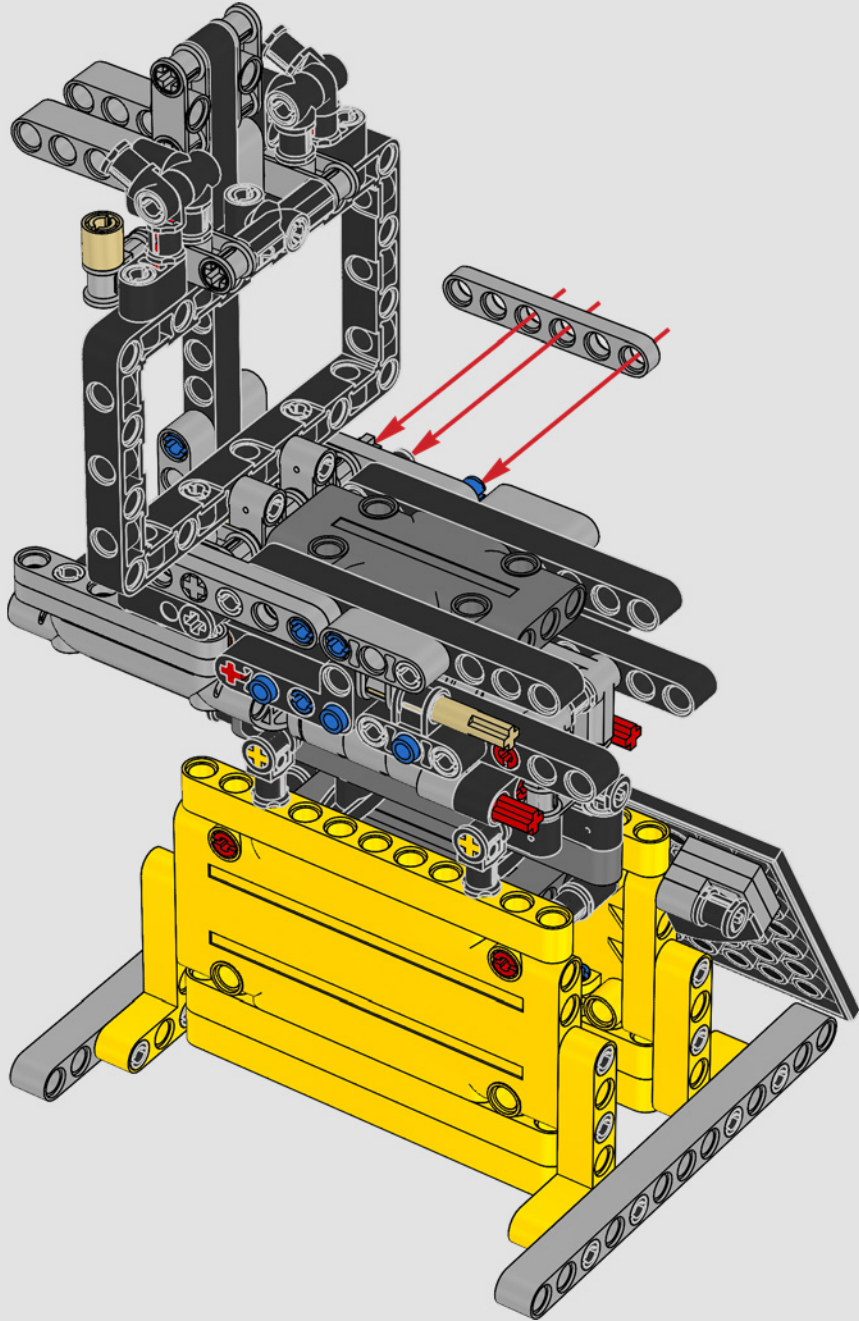

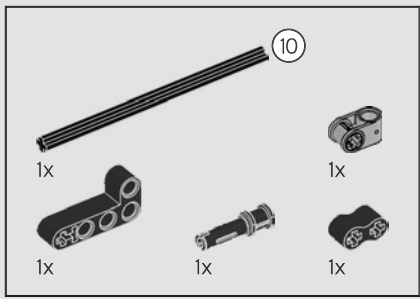

254

1

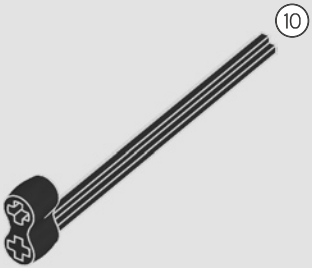

2

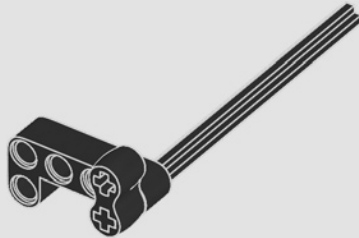

3

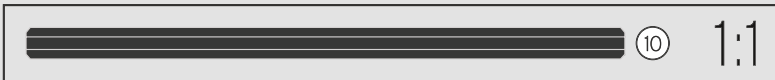
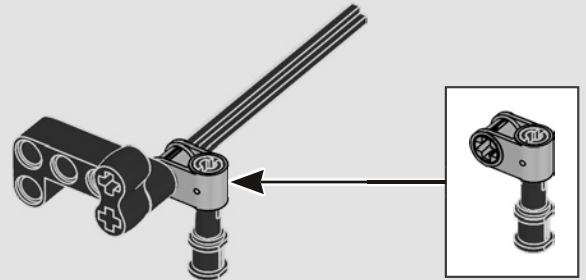

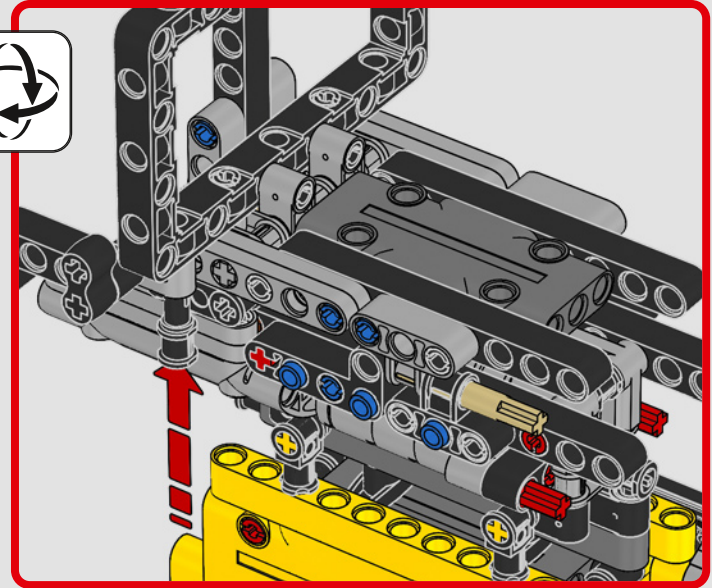
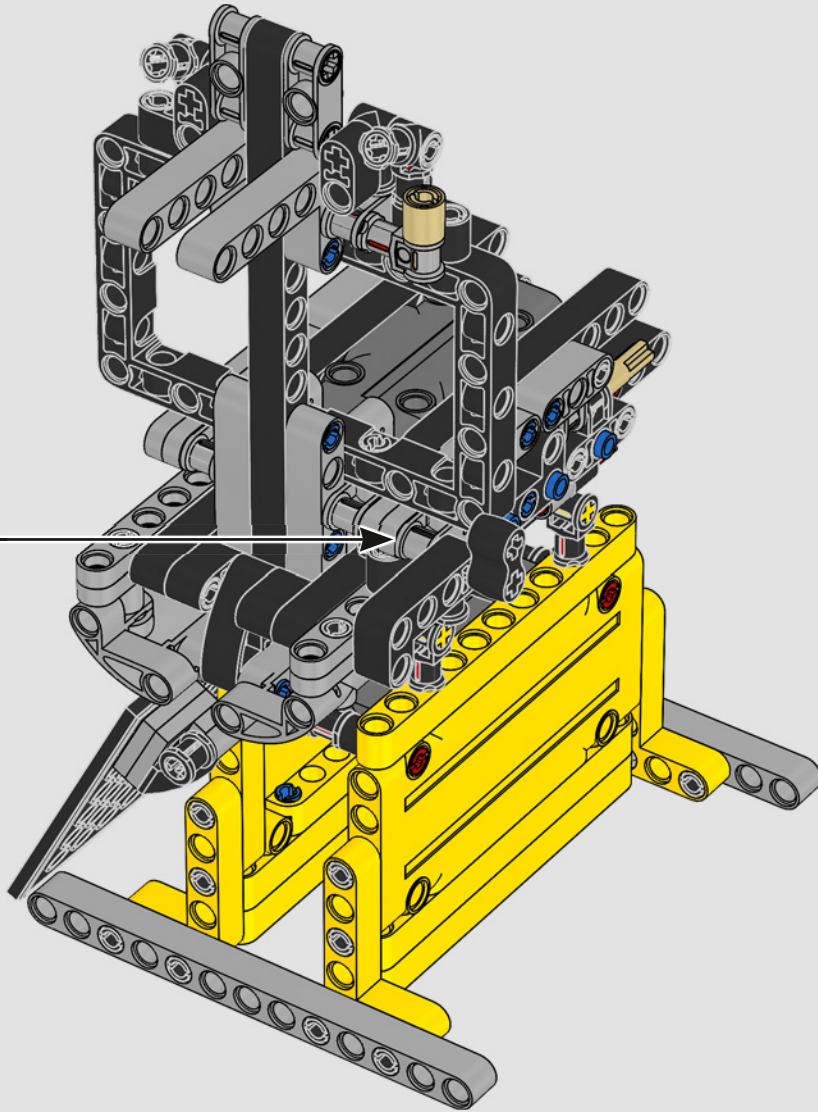

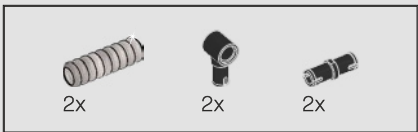

255

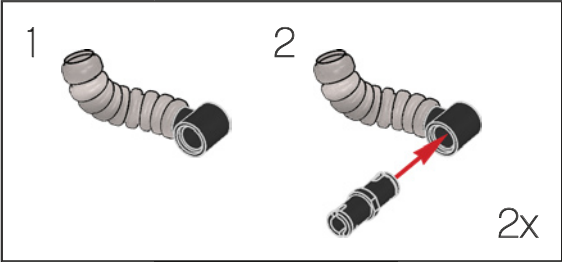
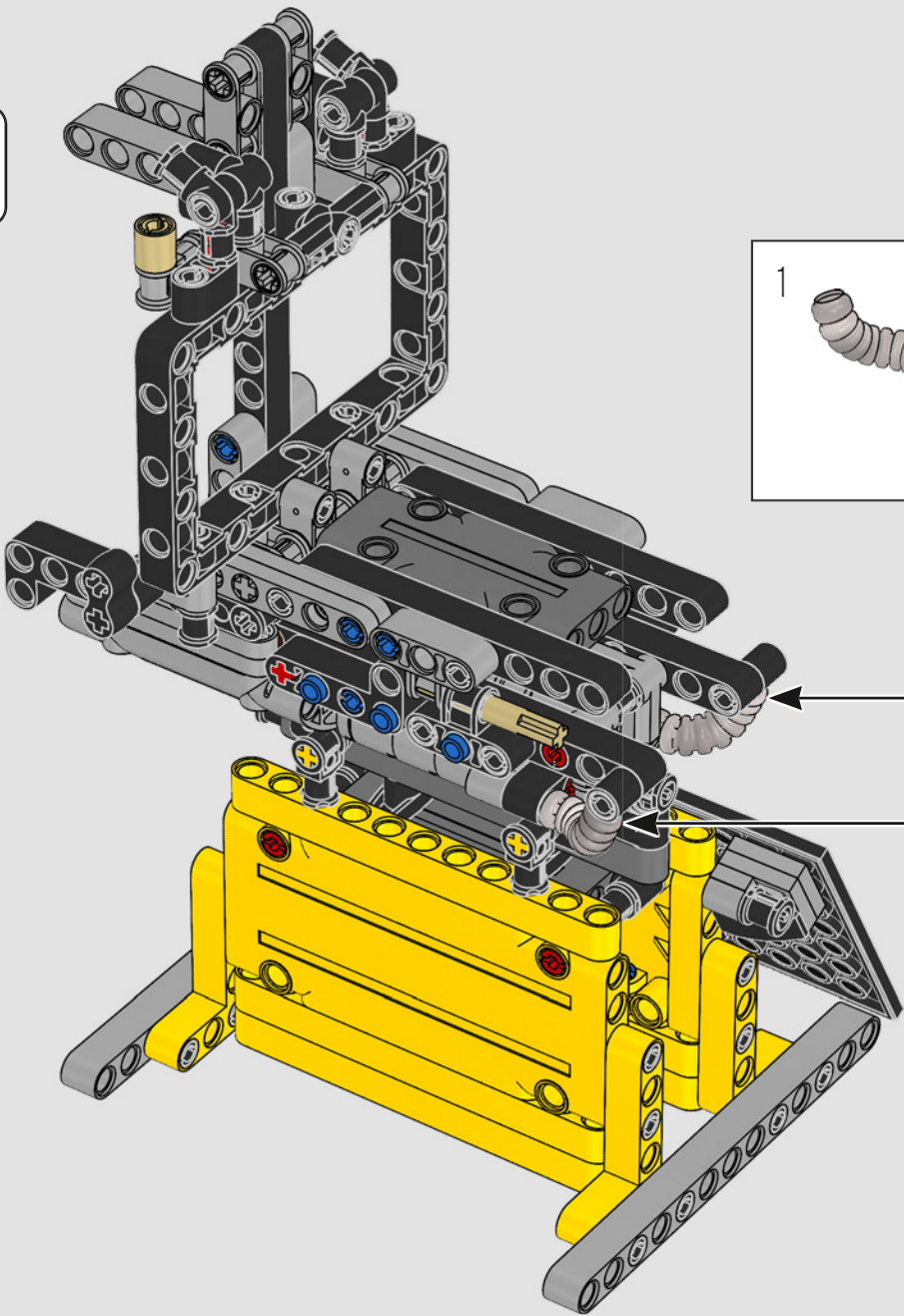

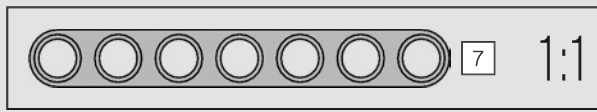
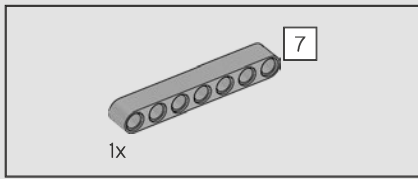

256

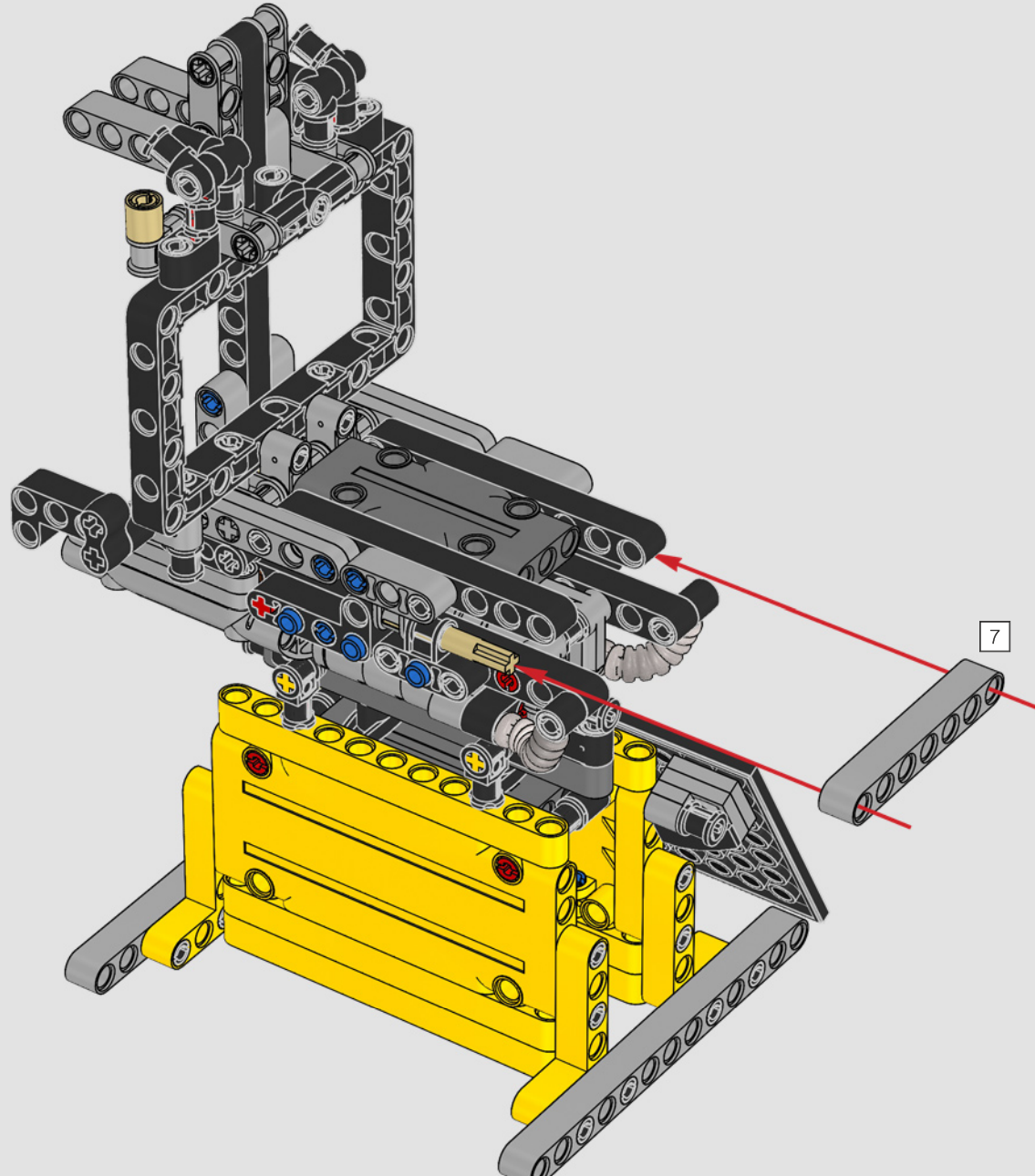

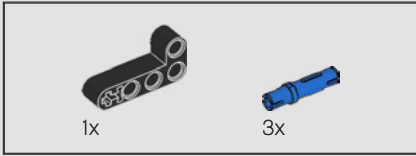
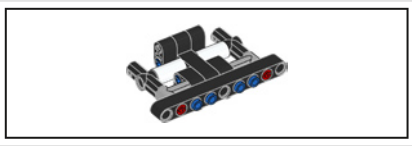

257

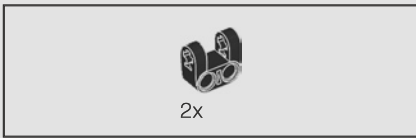
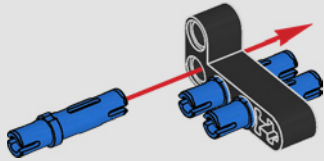

258

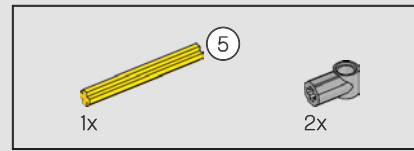
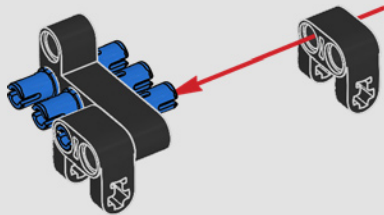

259

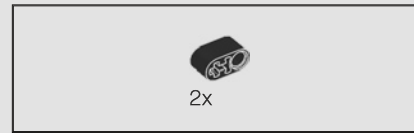
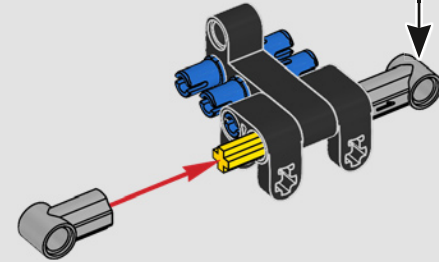
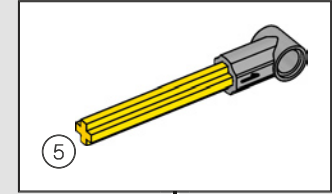

260

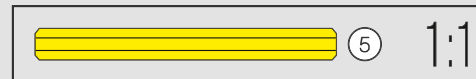
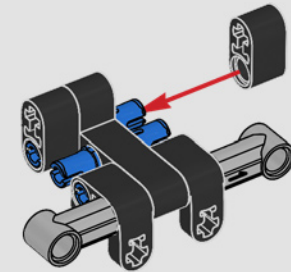



261

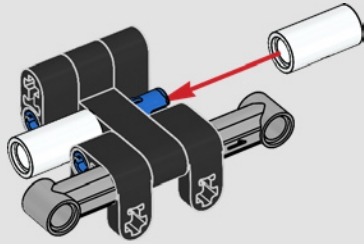

262

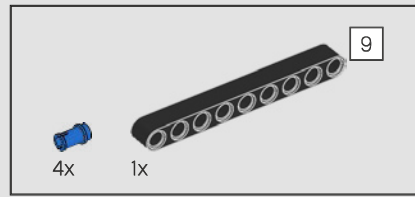
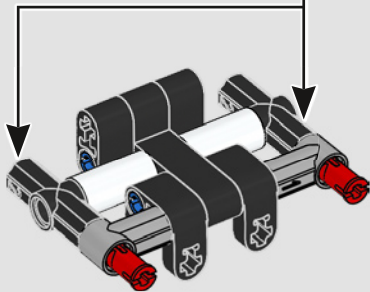
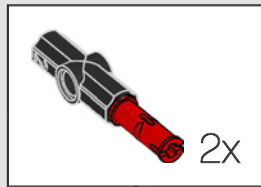

263

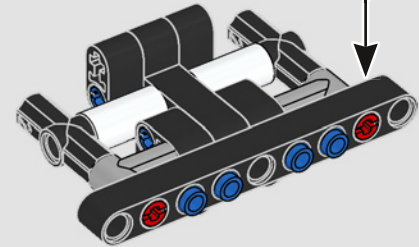
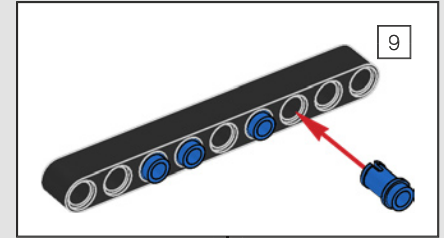

264

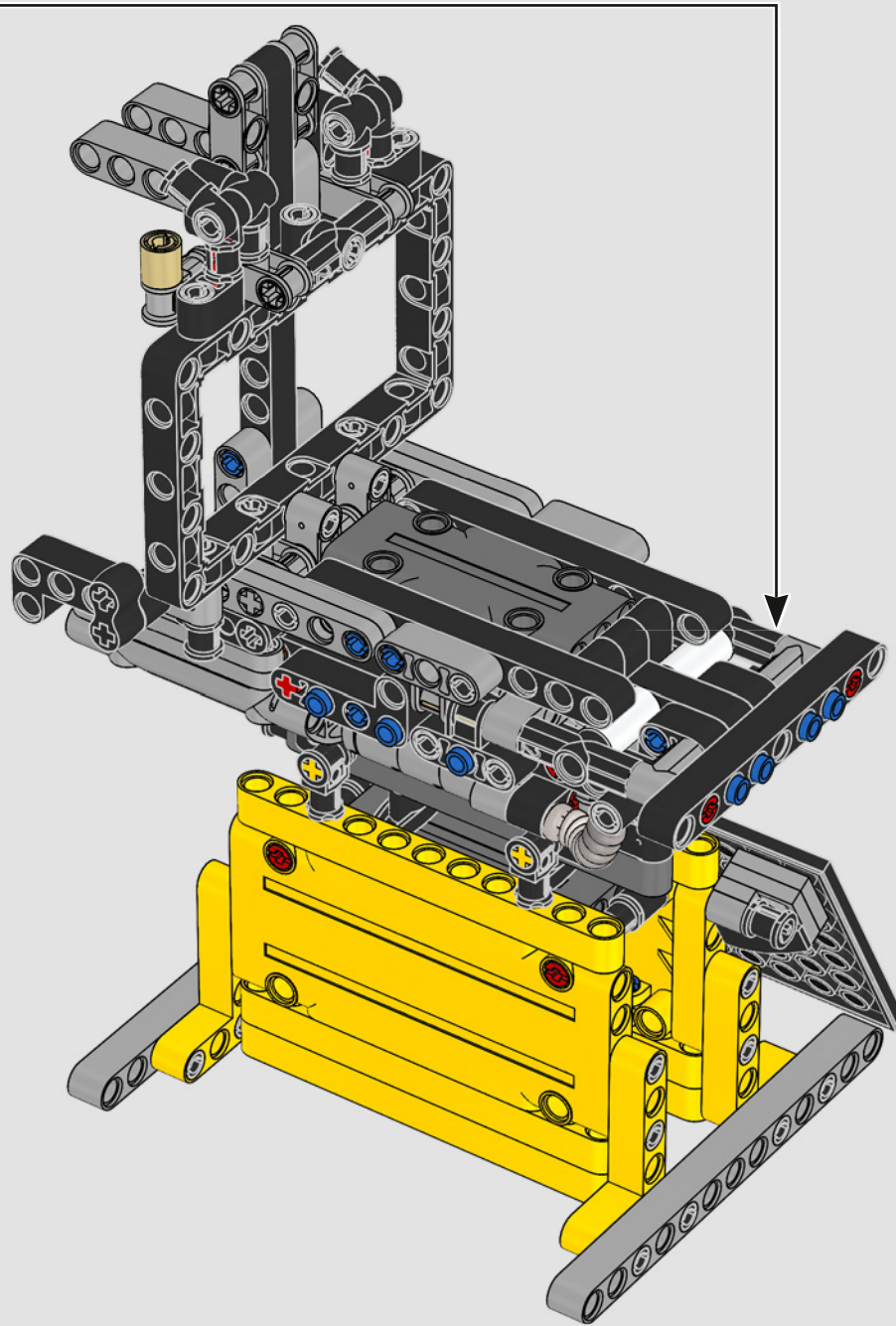

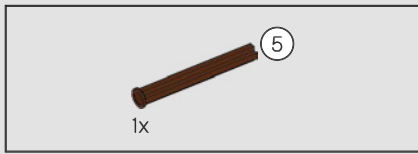

265

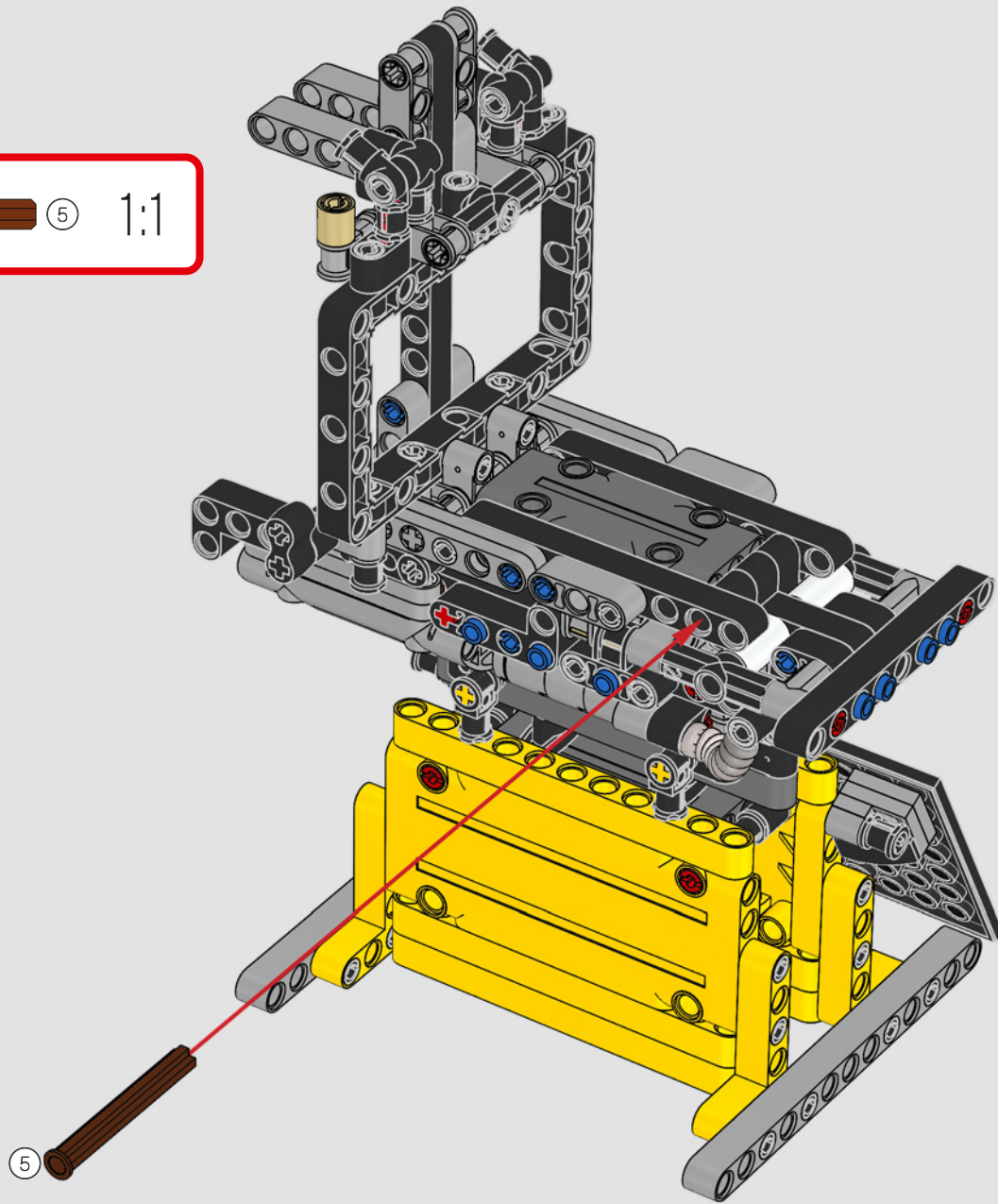

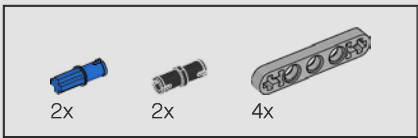

266

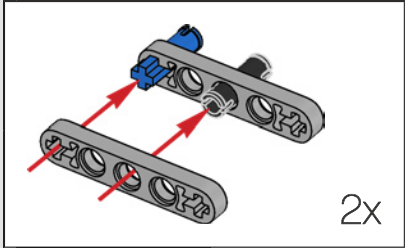
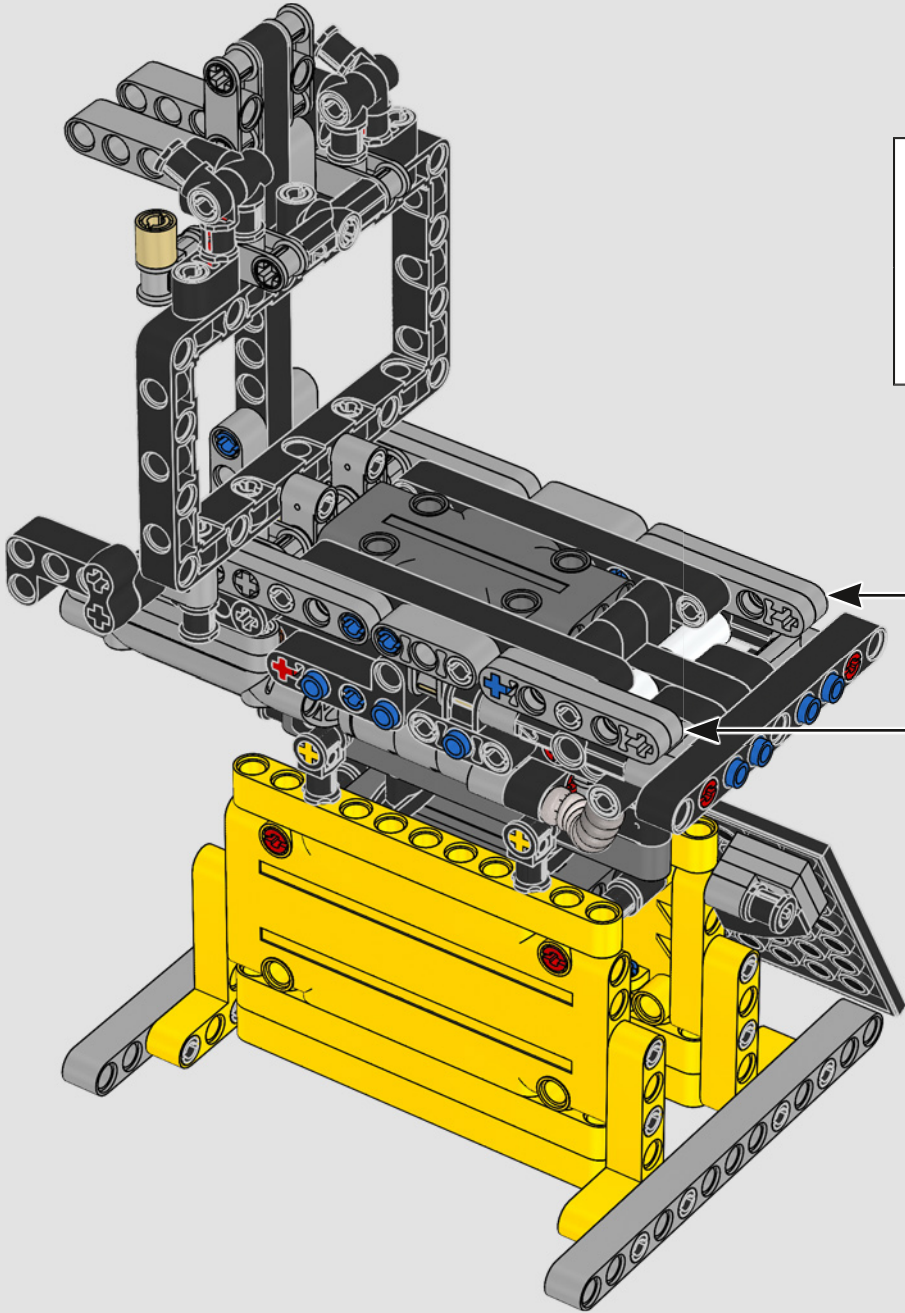

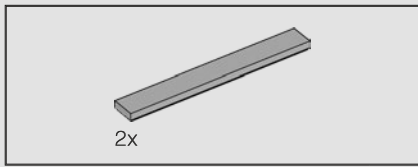

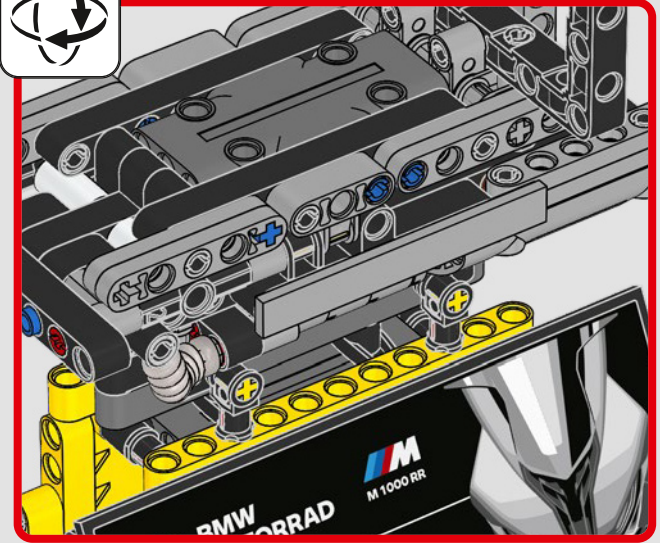
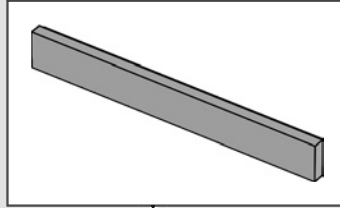
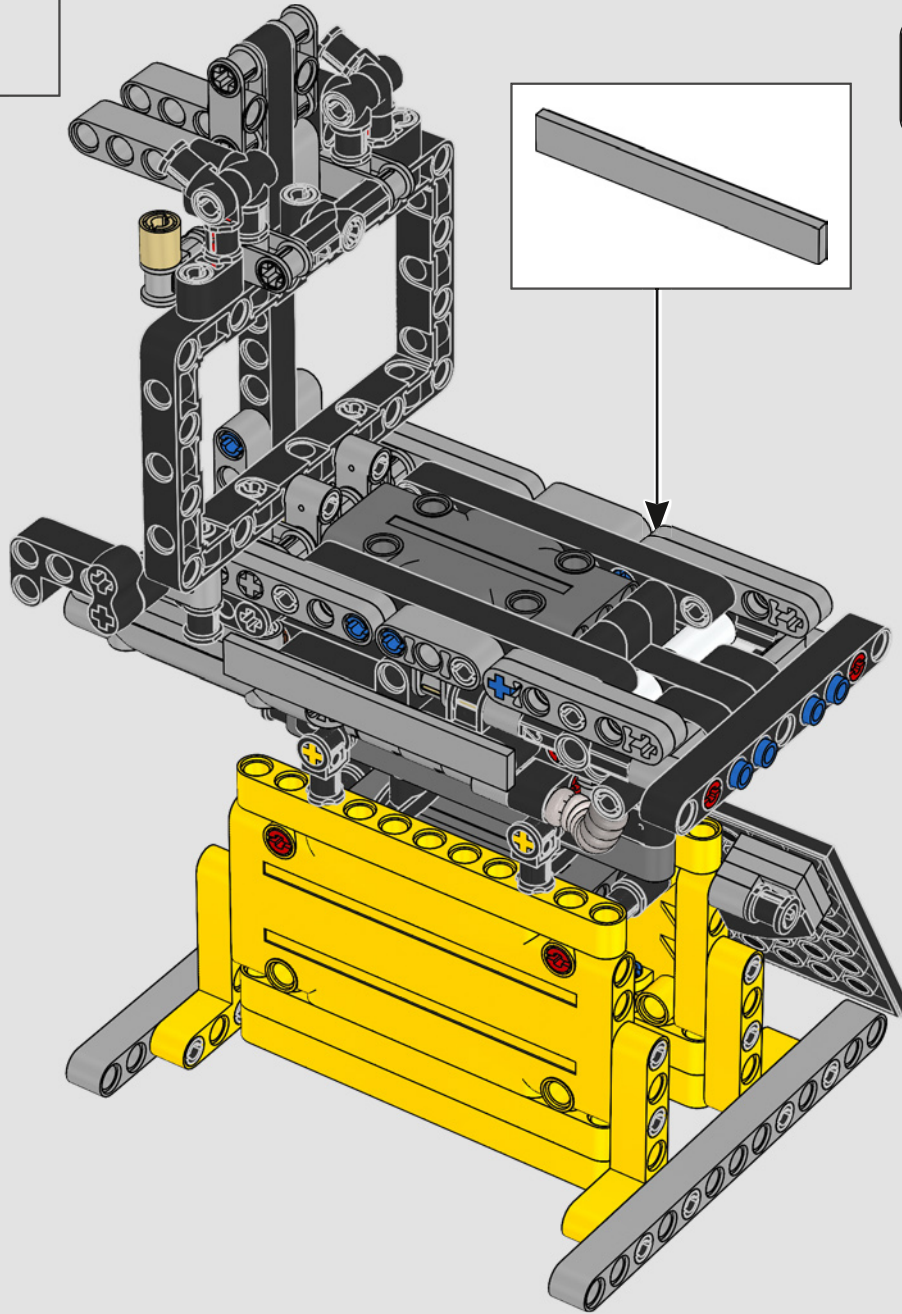

267

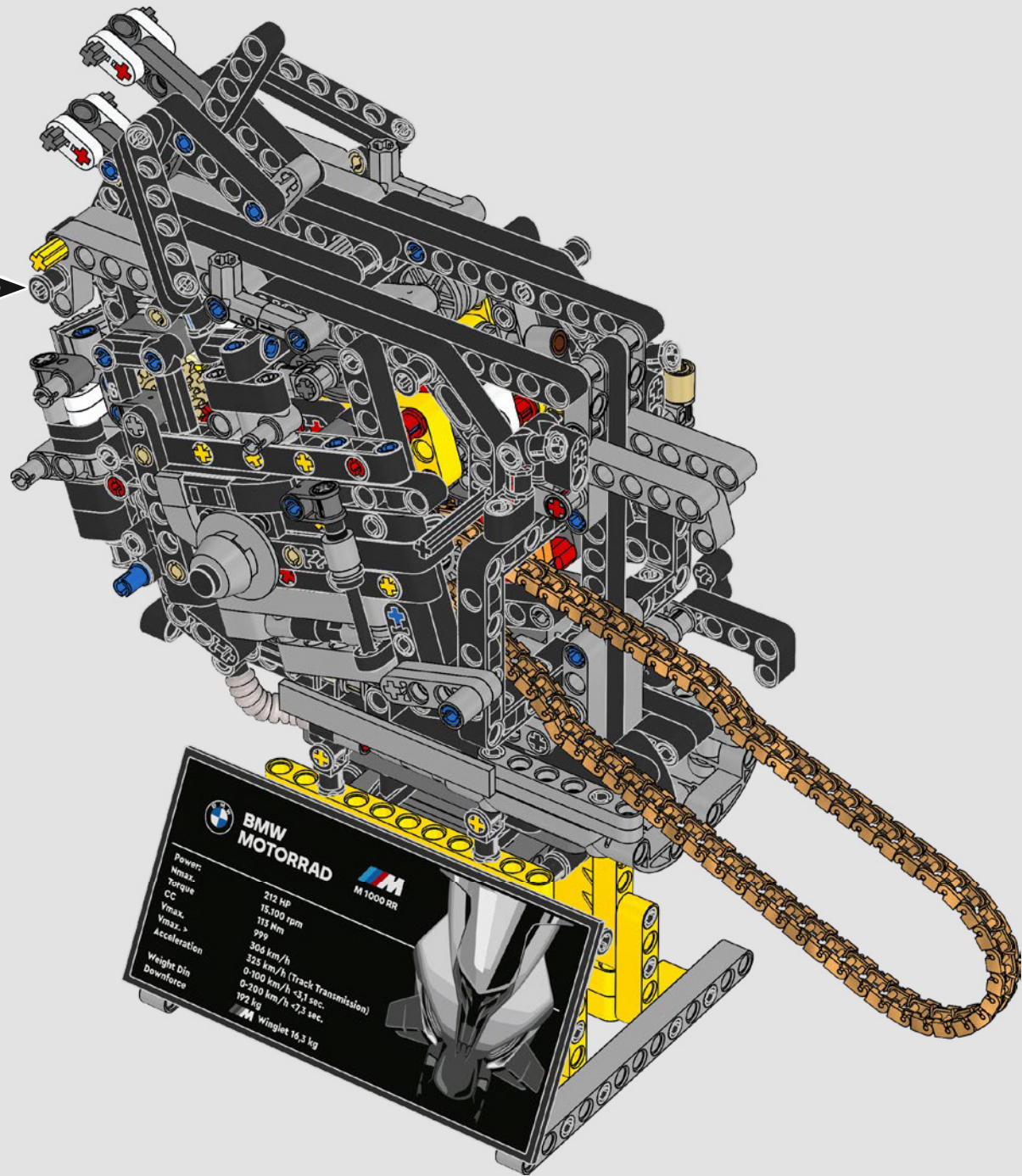

268



BMW MOTORRAD  **M 1000 RR**

Power: 212 HP
Nmax. 15,100 rpm
Torque 113 Nm
CC 999
Vmax. 306 km/h
Vmax. > 325 km/h (Track Transmission)
Acceleration 0-100 km/h < 3,1 sec.
0-200 km/h < 7,3 sec.
Weight Din 192 kg
Downforce  Winglet 16,3 kg



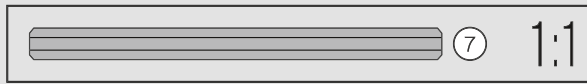
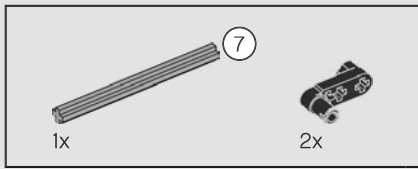

269

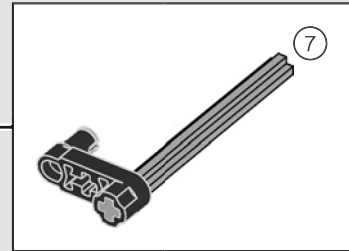
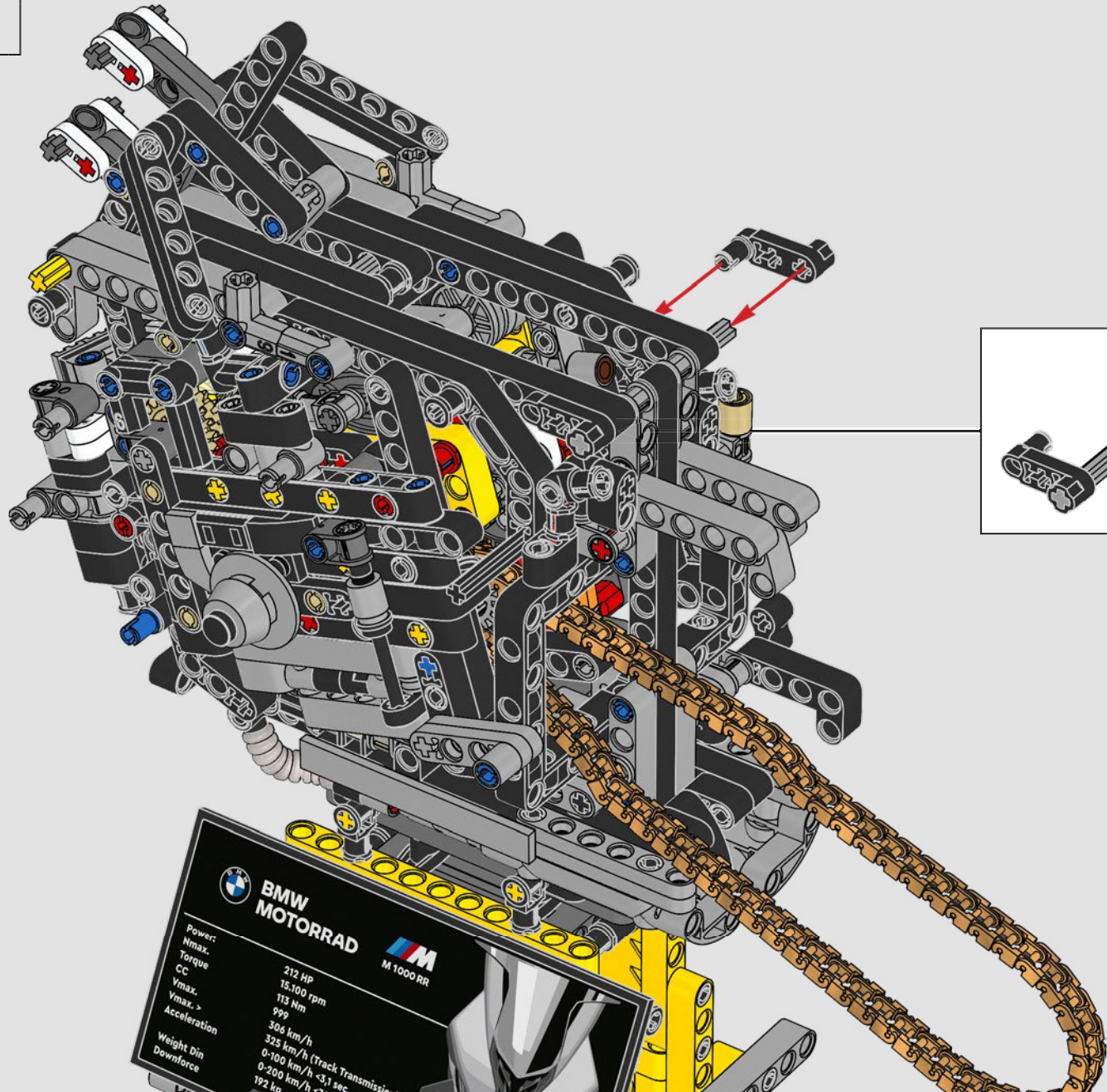

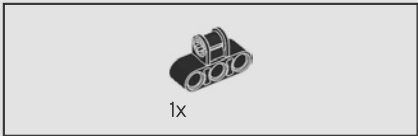

BMW MOTORRAD		M 1000 RR
Power:	212 HP	
Nmax:	15.100 rpm	
Torque	113 Nm	
CC	999	
Vmax:	326 km/h	
Vmax. >	325 km/h (Track Transmission)	
Acceleration	0-100 km/h < 3.1 sec	
Weight Din	192 kg	
Downforce		

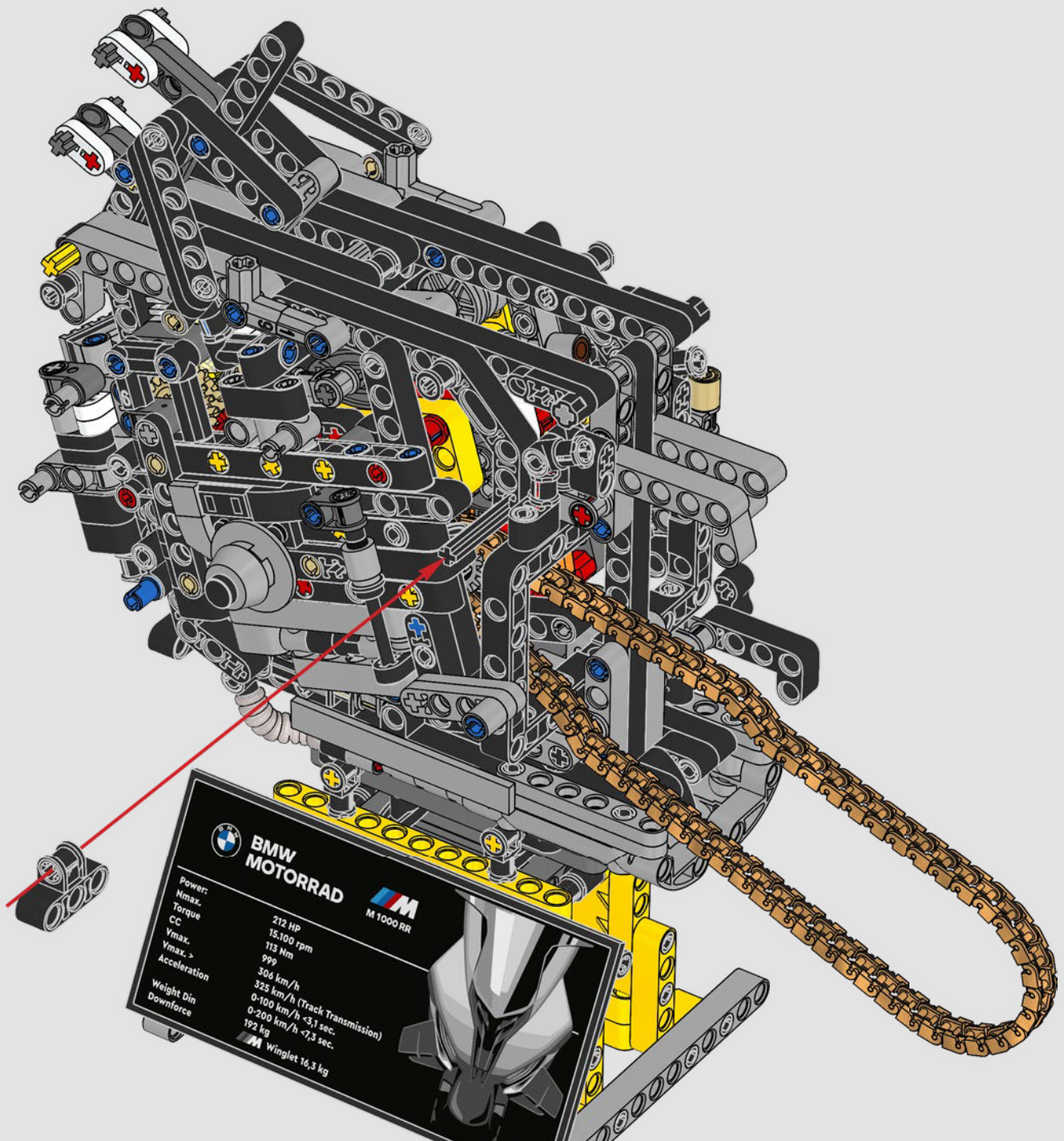

270



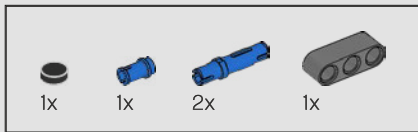

BMW MOTORRAD  

Power:	212 HP
Hmax:	15-100 rpm
Torque	113 Nm
CC	999
Vmax:	306 km/h
Vmax. >	326 km/h (Track Transmission)
Acceleration	0-100 km/h <3,1 sec.
Weight Din	0-200 km/h ~7,3 sec.
Downforce	192 kg
	 Winglet 16,3 kg

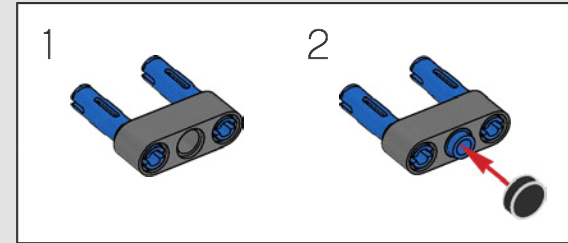
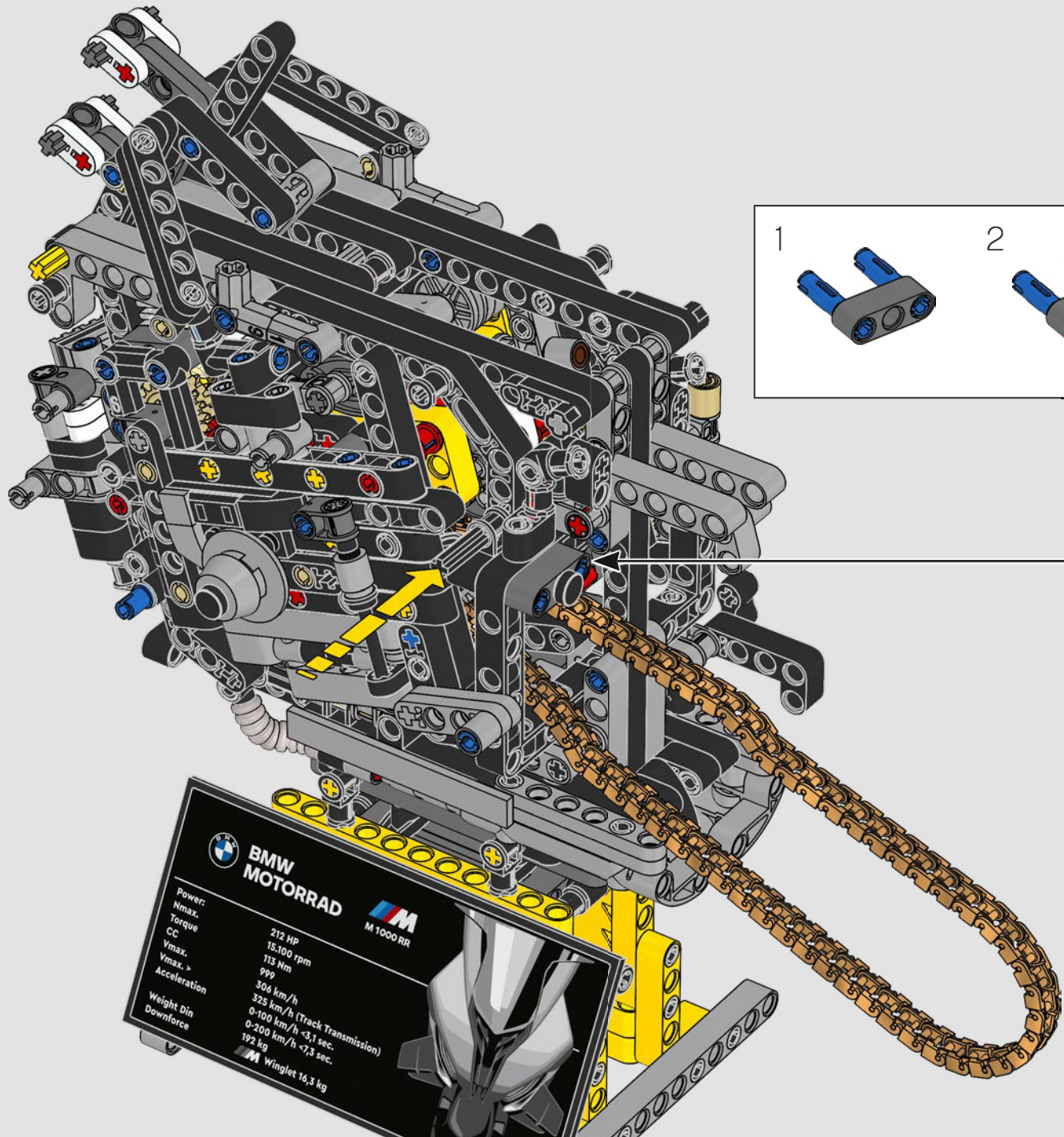

271



BMW MOTORRAD  

Power:	212 HP
Nmax:	15.100 rpm
Torque	113 Nm
CC	999
Vmax:	306 km/h
Vmax. >	325 km/h (Track Transmission)
Acceleration	0-100 km/h < 3,1 sec.
Weight Din	192 kg
Downforce	0-200 km/h < 7,3 sec.
	 Winglet 16,3 kg



272

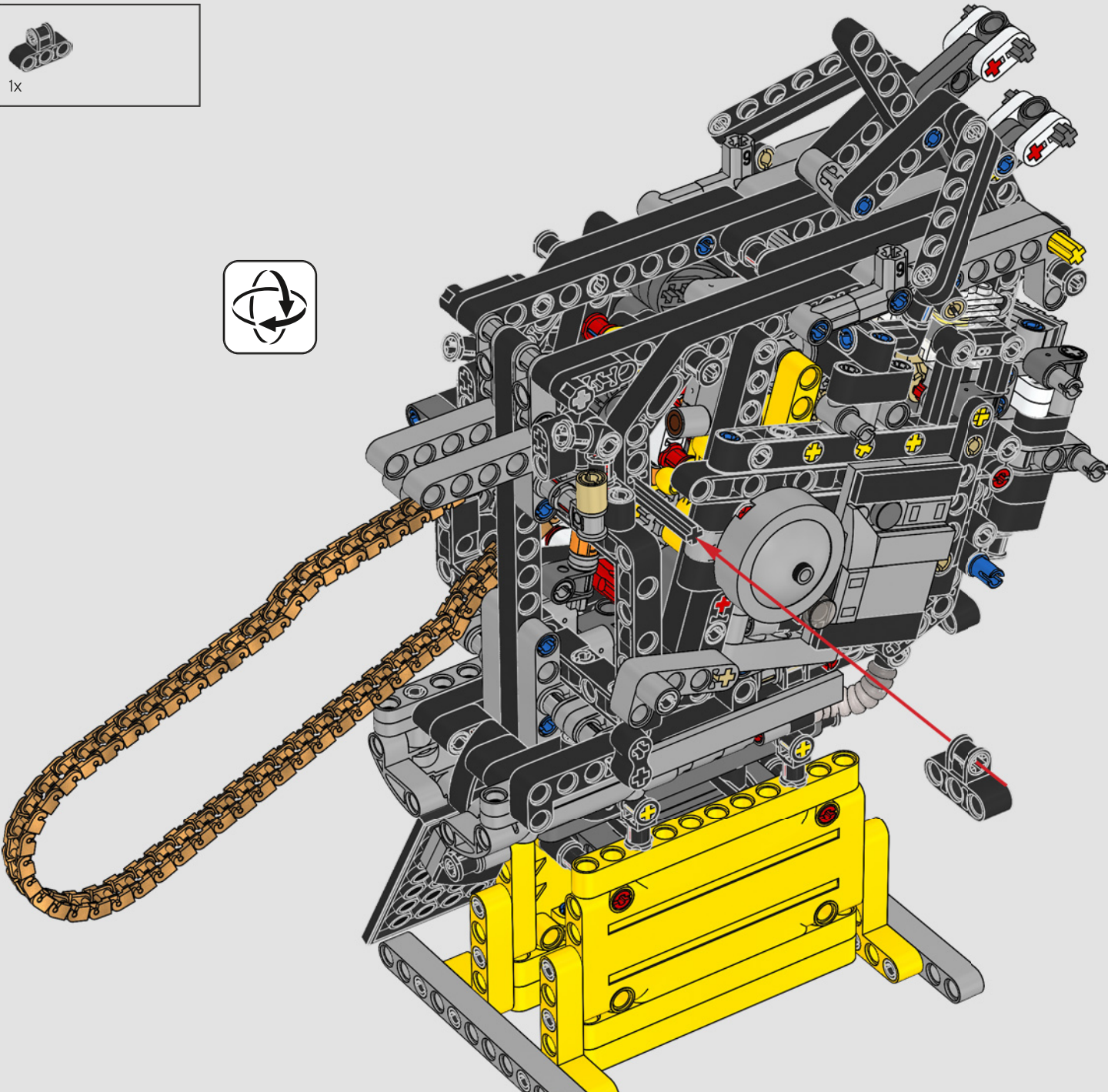

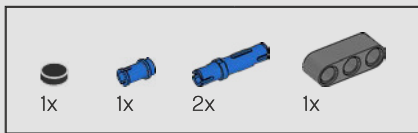

273

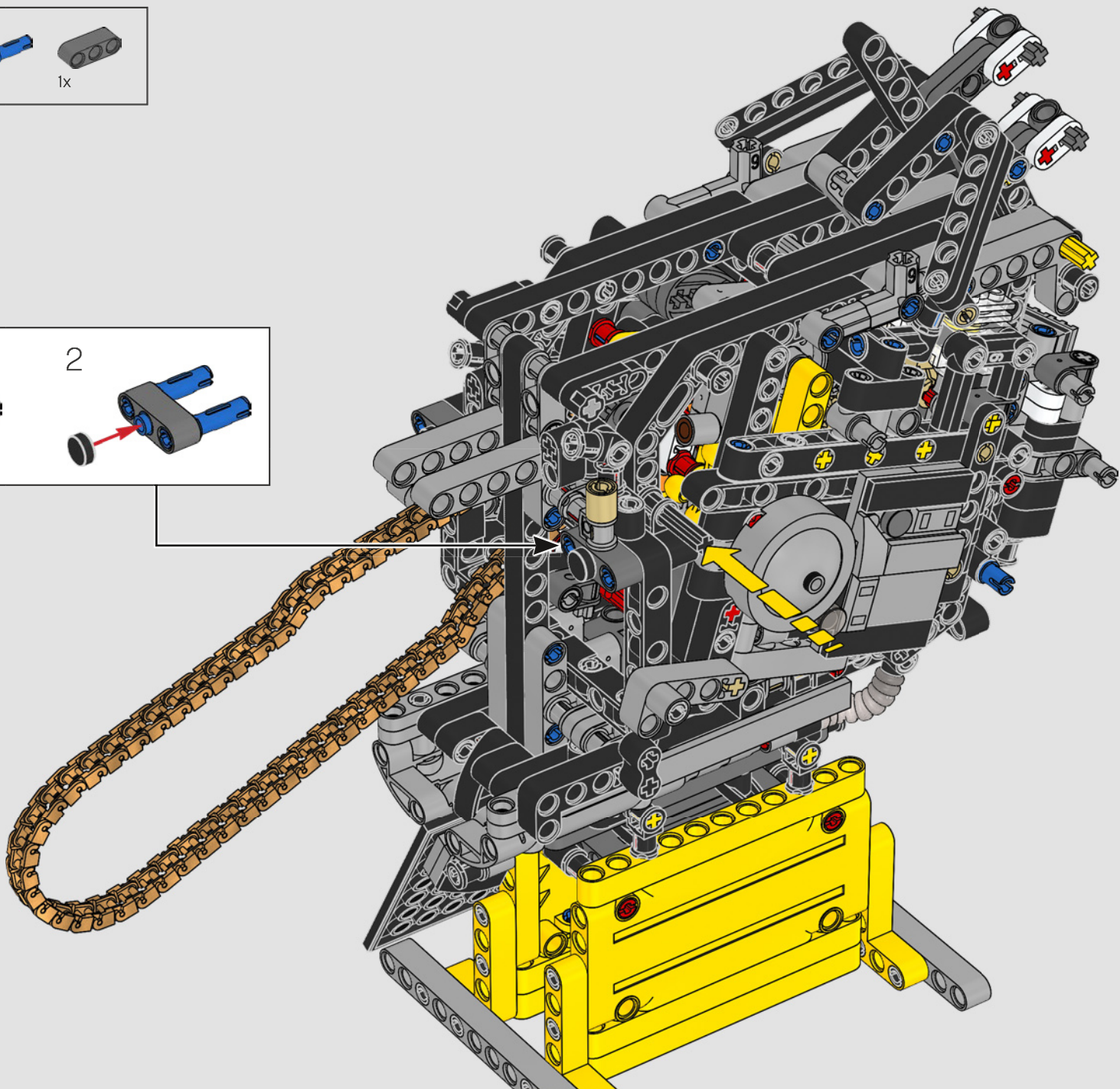
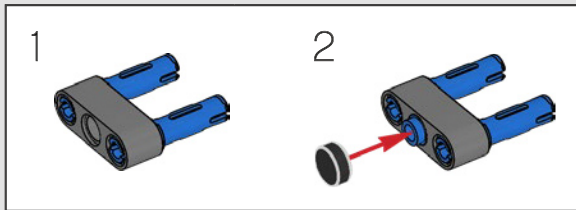

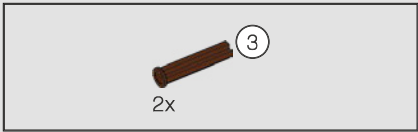

274

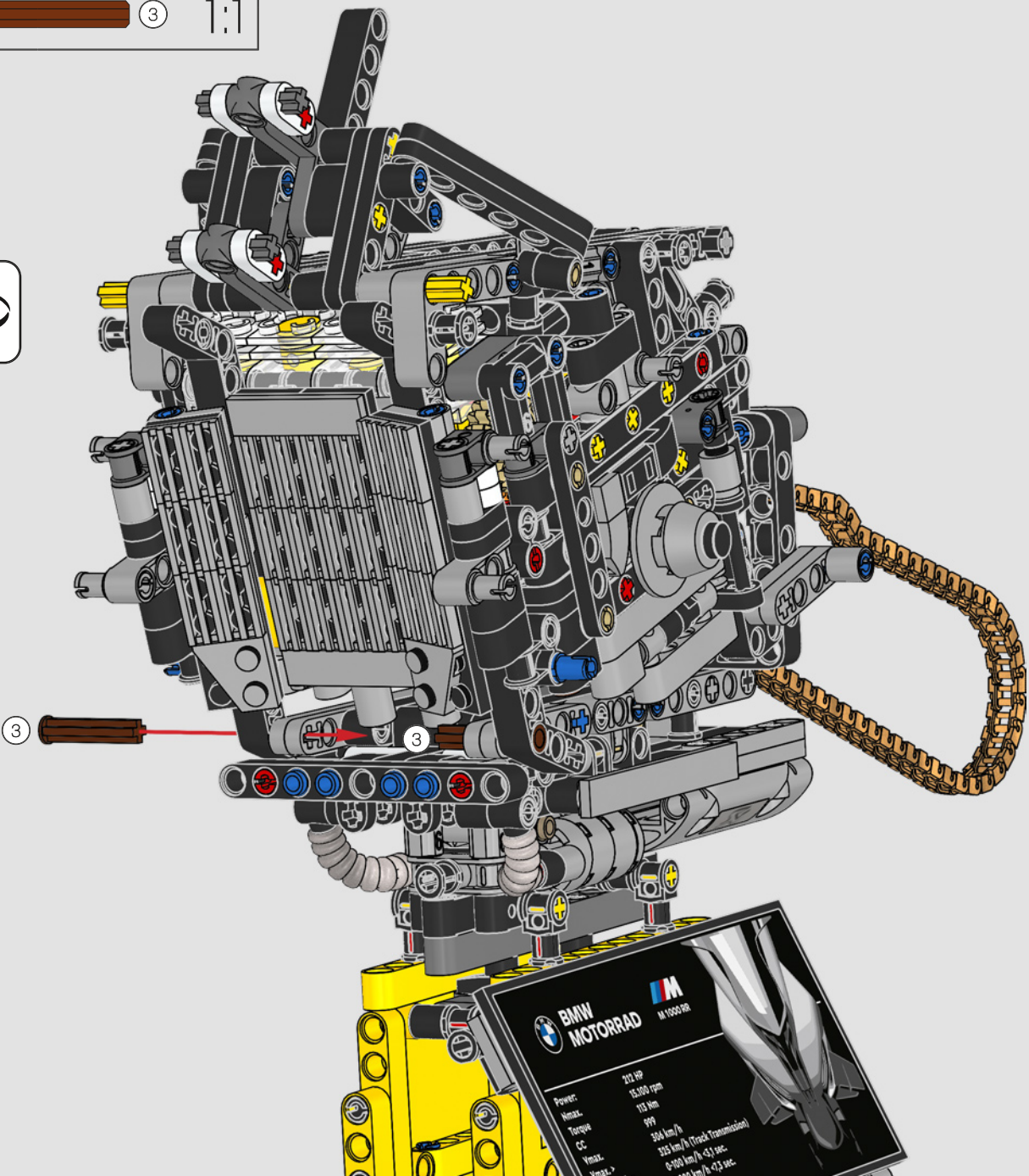



2x



3x



2x

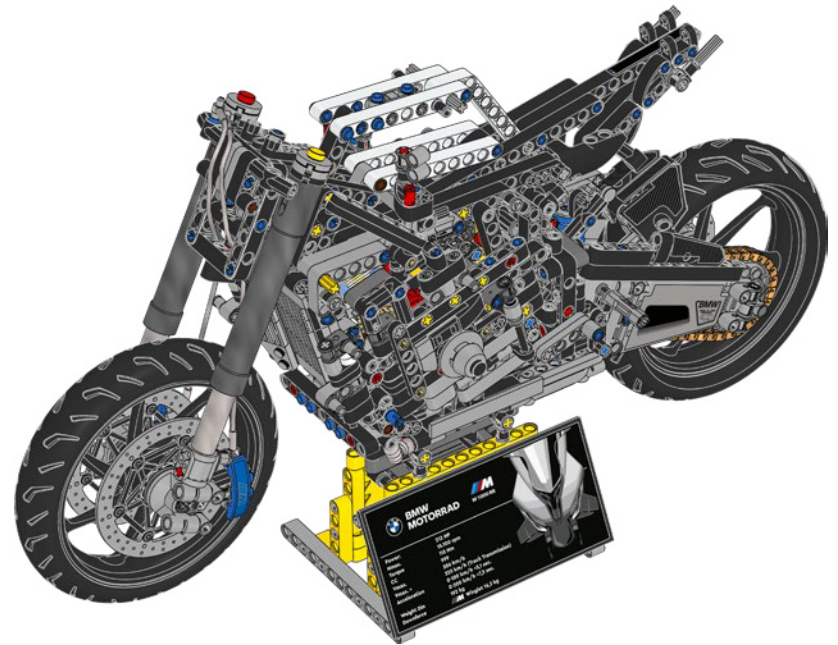
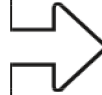



2x

275



2x

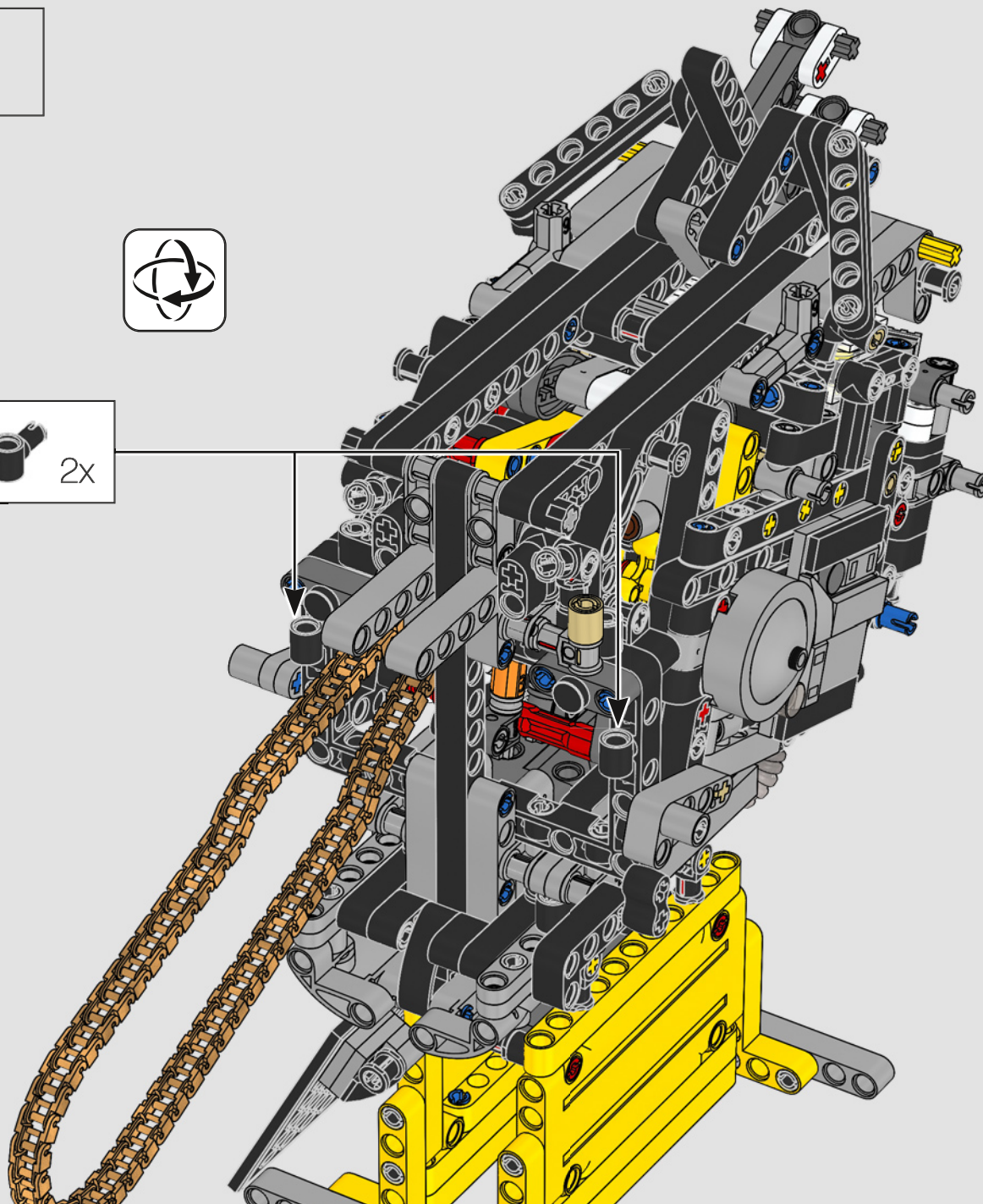

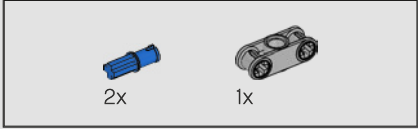
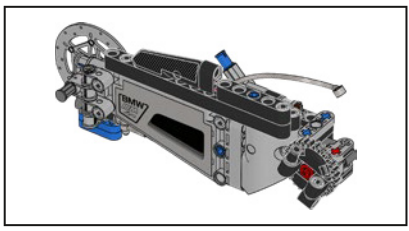

276

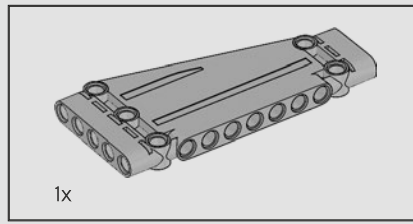
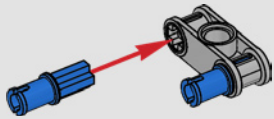

277

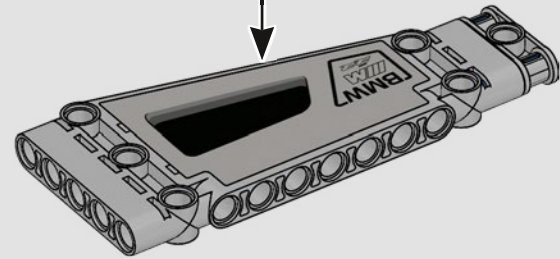
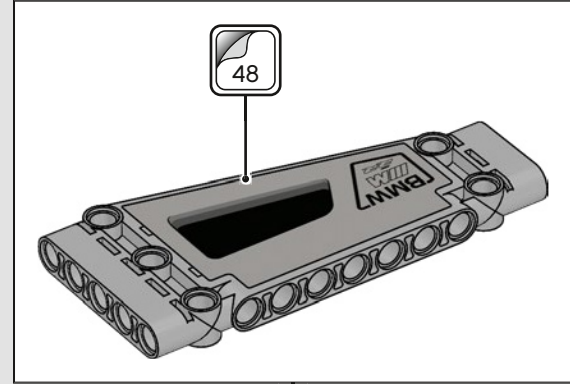

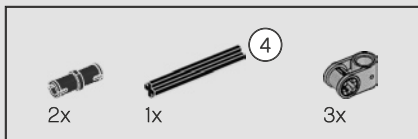

278

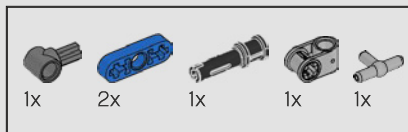
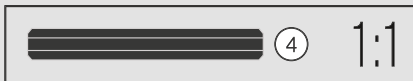
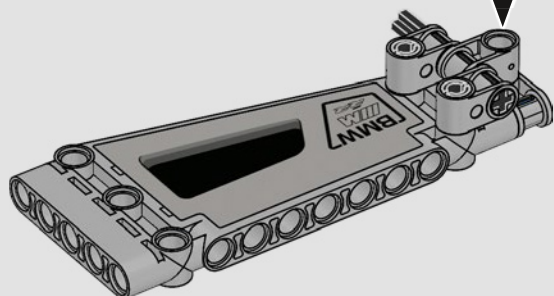
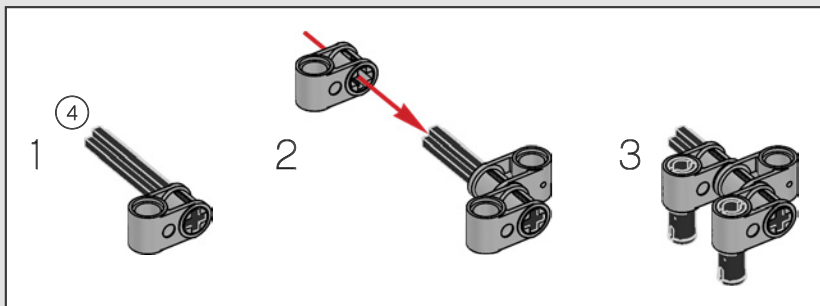

279

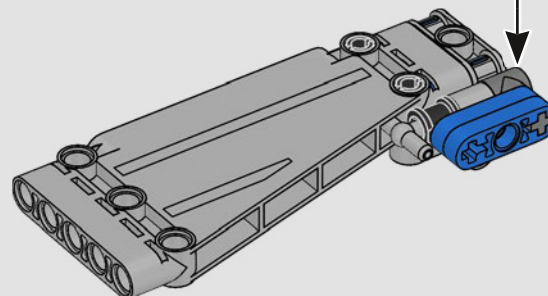
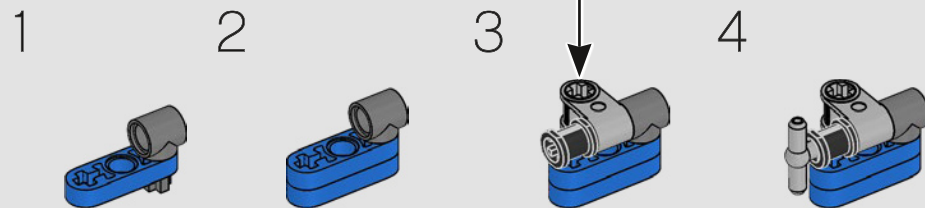
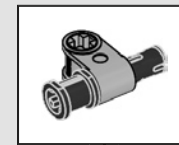

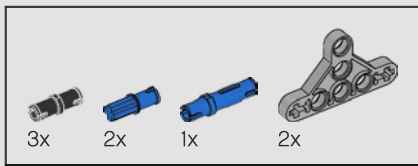

280

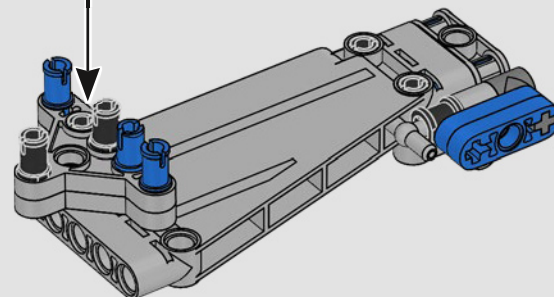
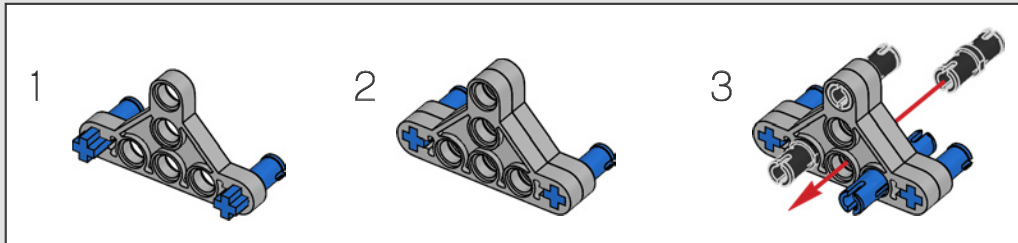

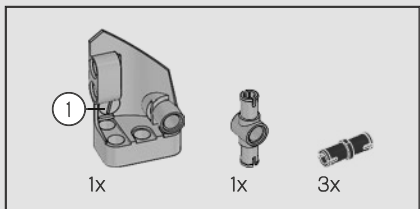

281

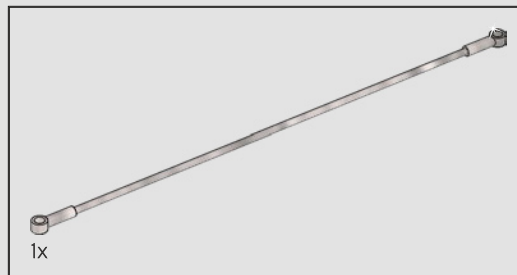
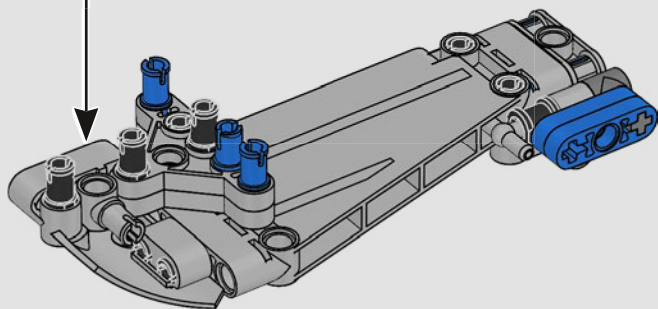
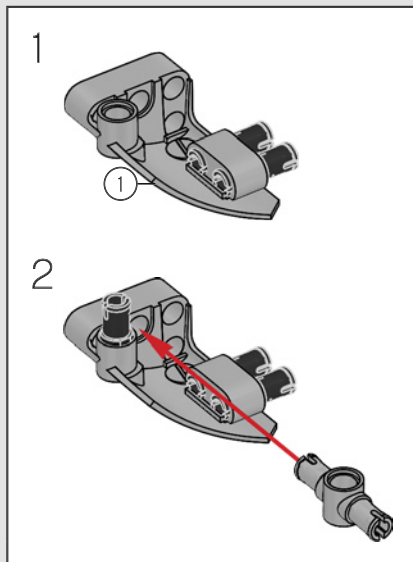

282

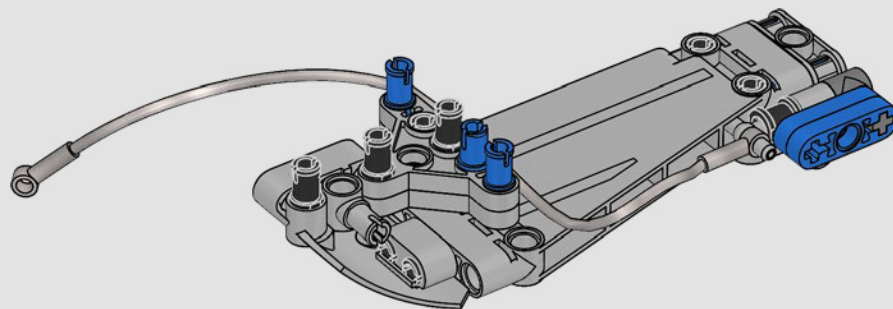

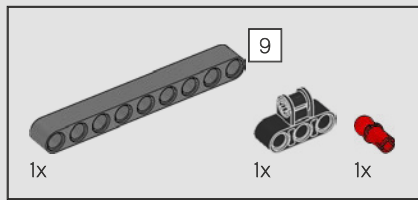

283

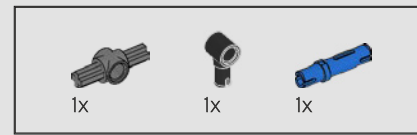
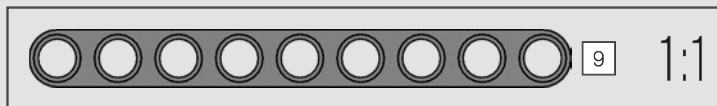
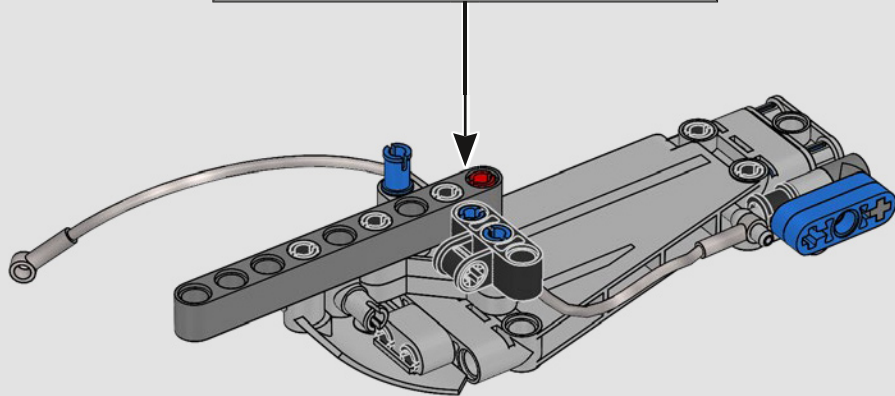
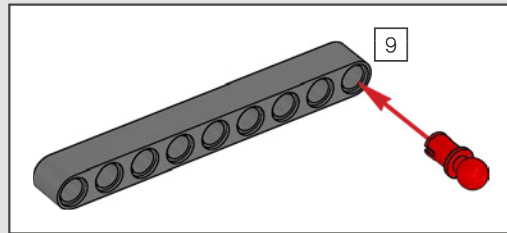
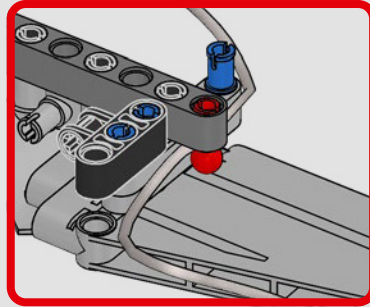

284

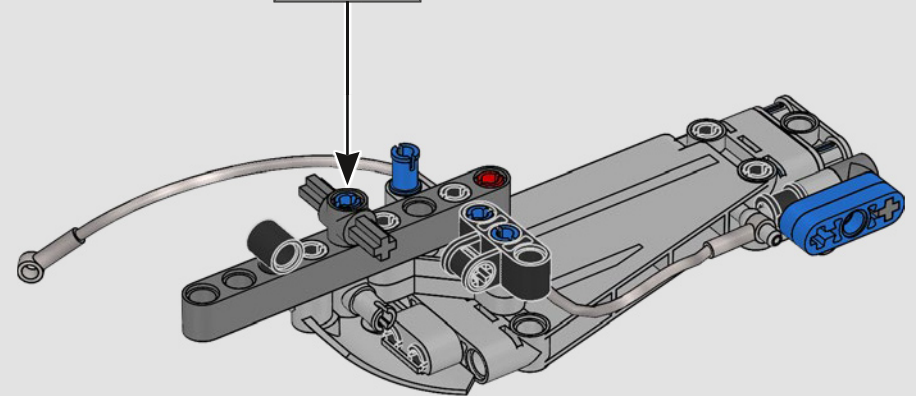
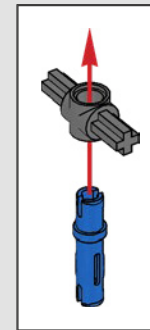

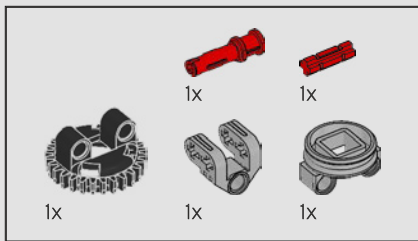

285

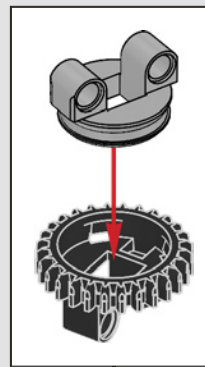

1

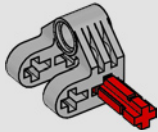

2

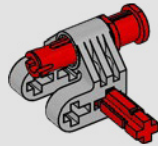

3

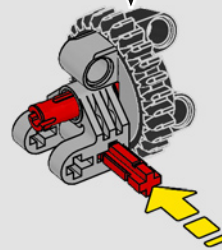

4

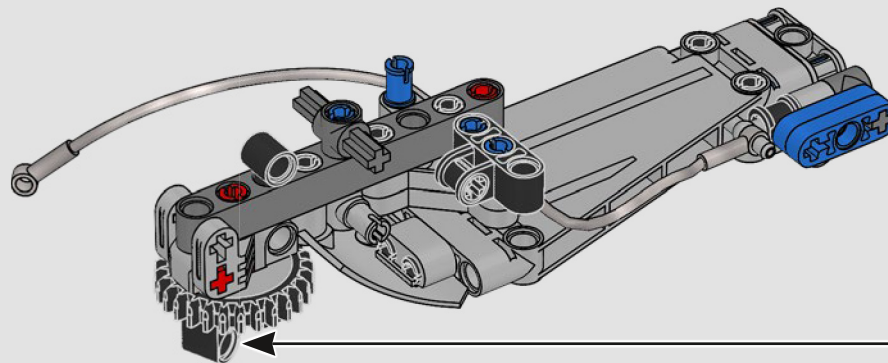

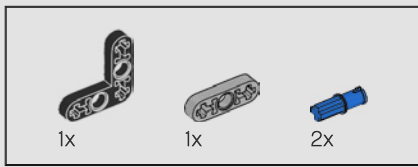

286

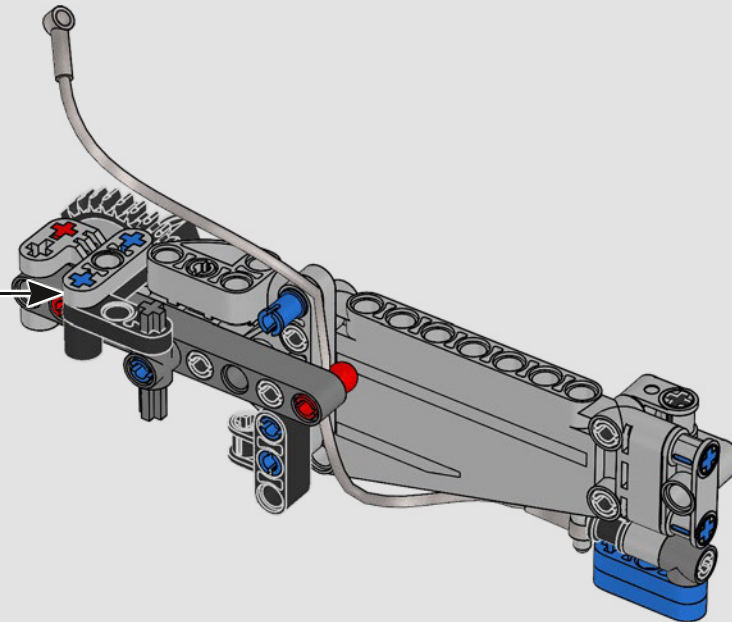
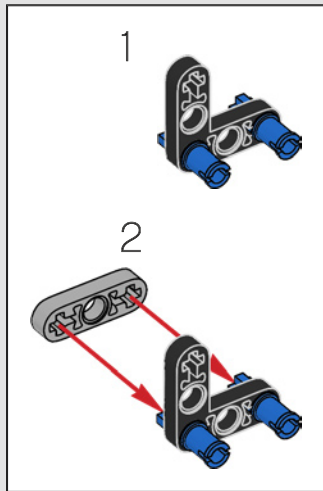

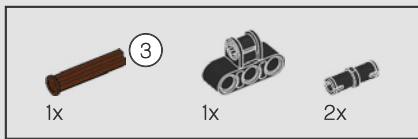

287

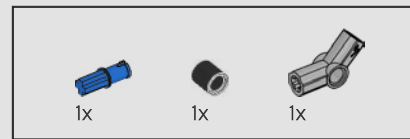
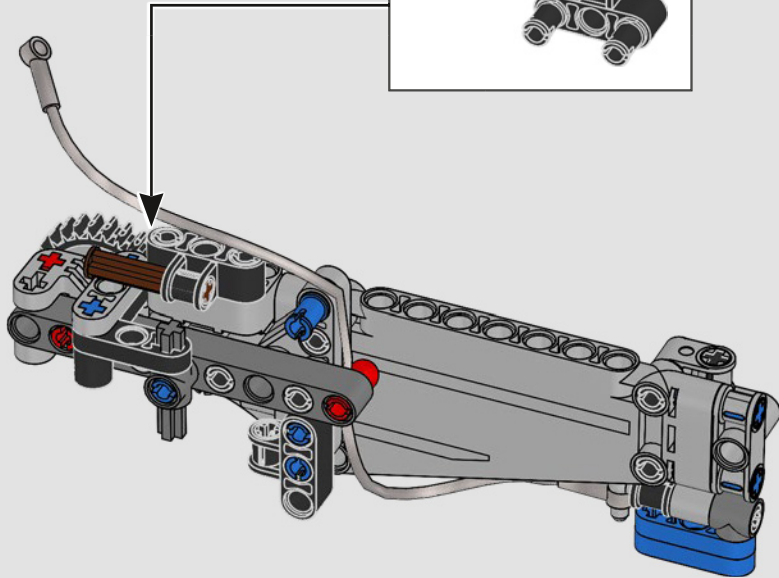
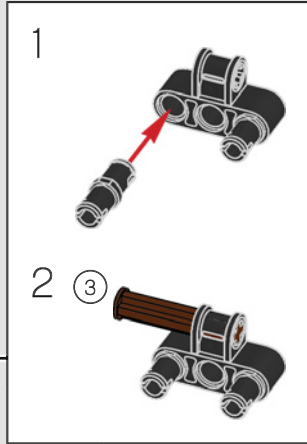

288

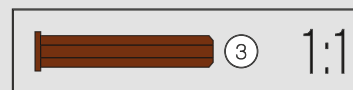
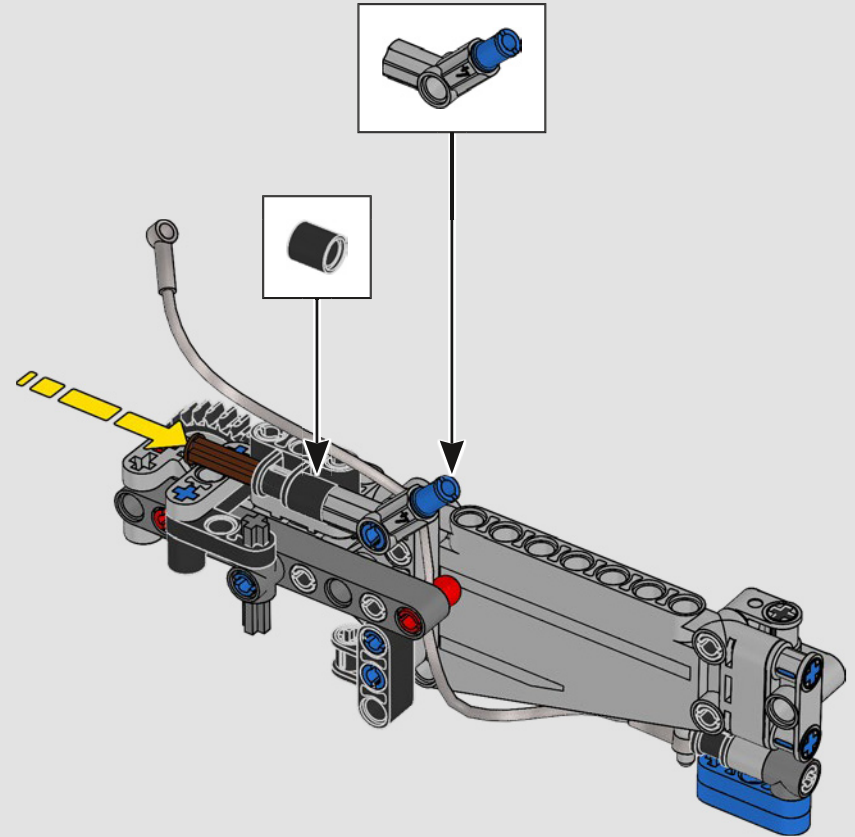

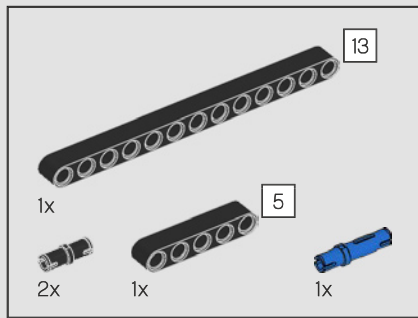

289

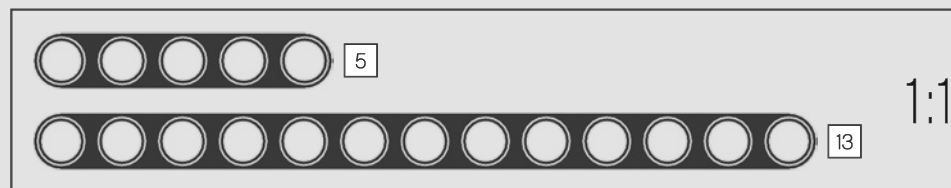
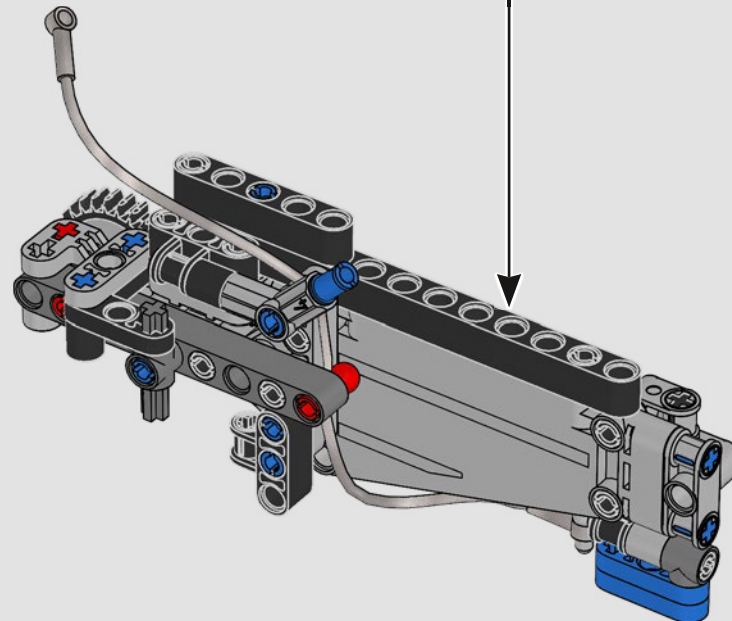
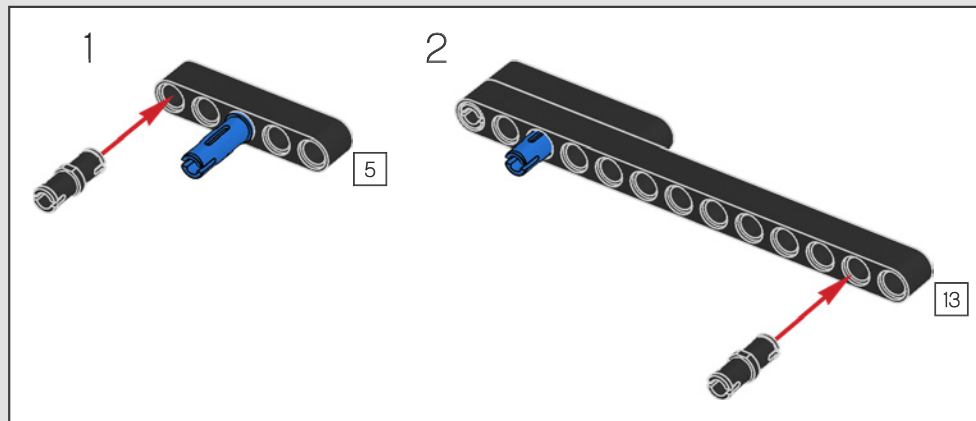

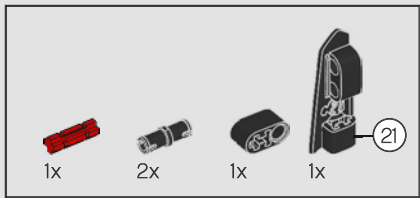

290

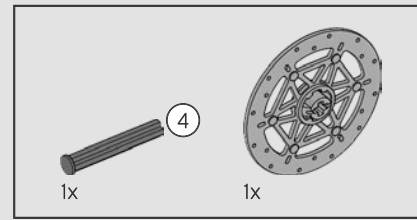
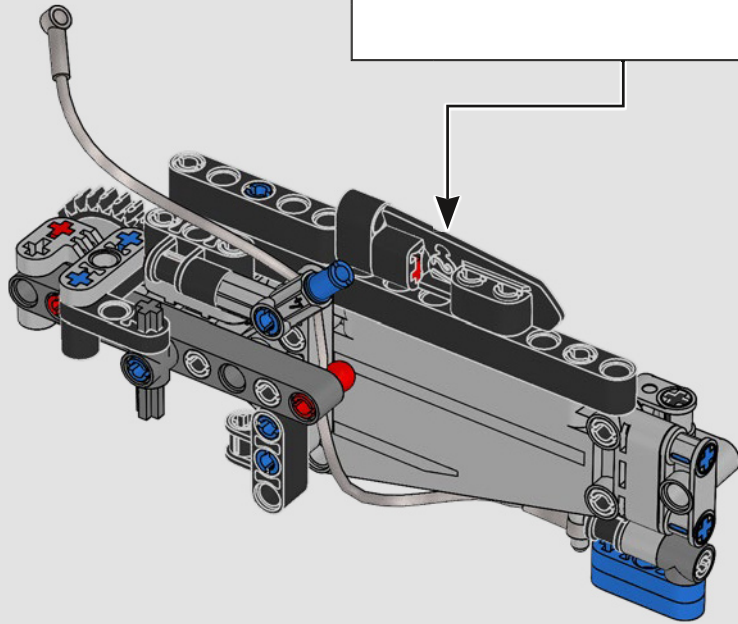
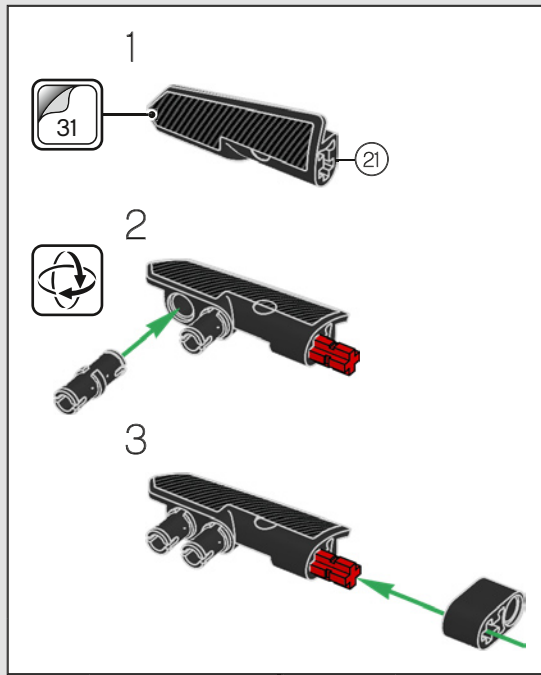

291

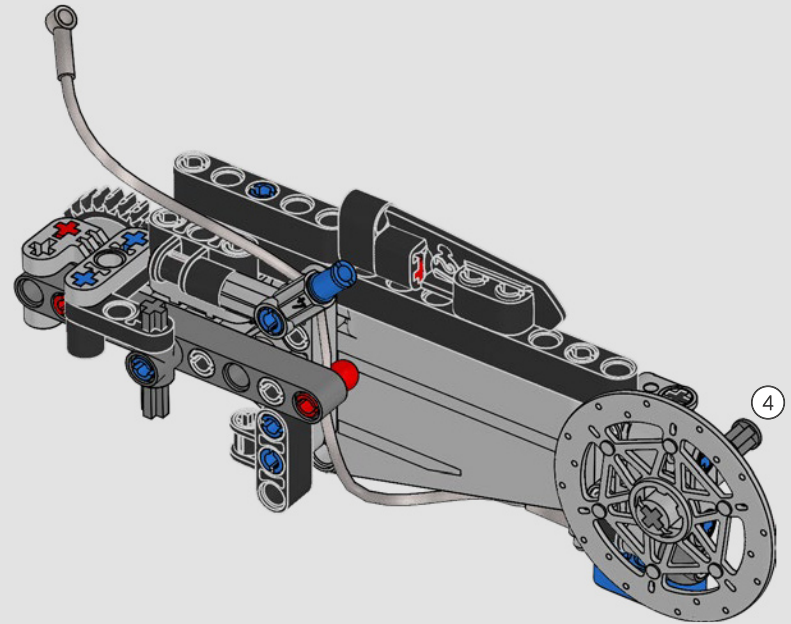
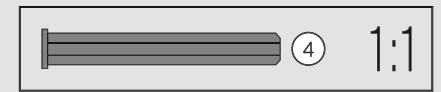

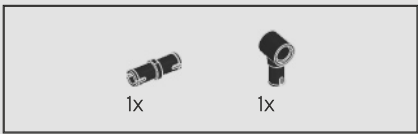

292

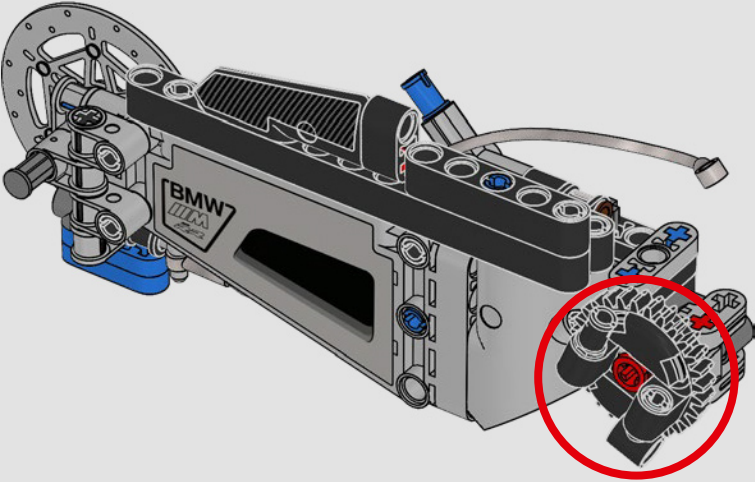

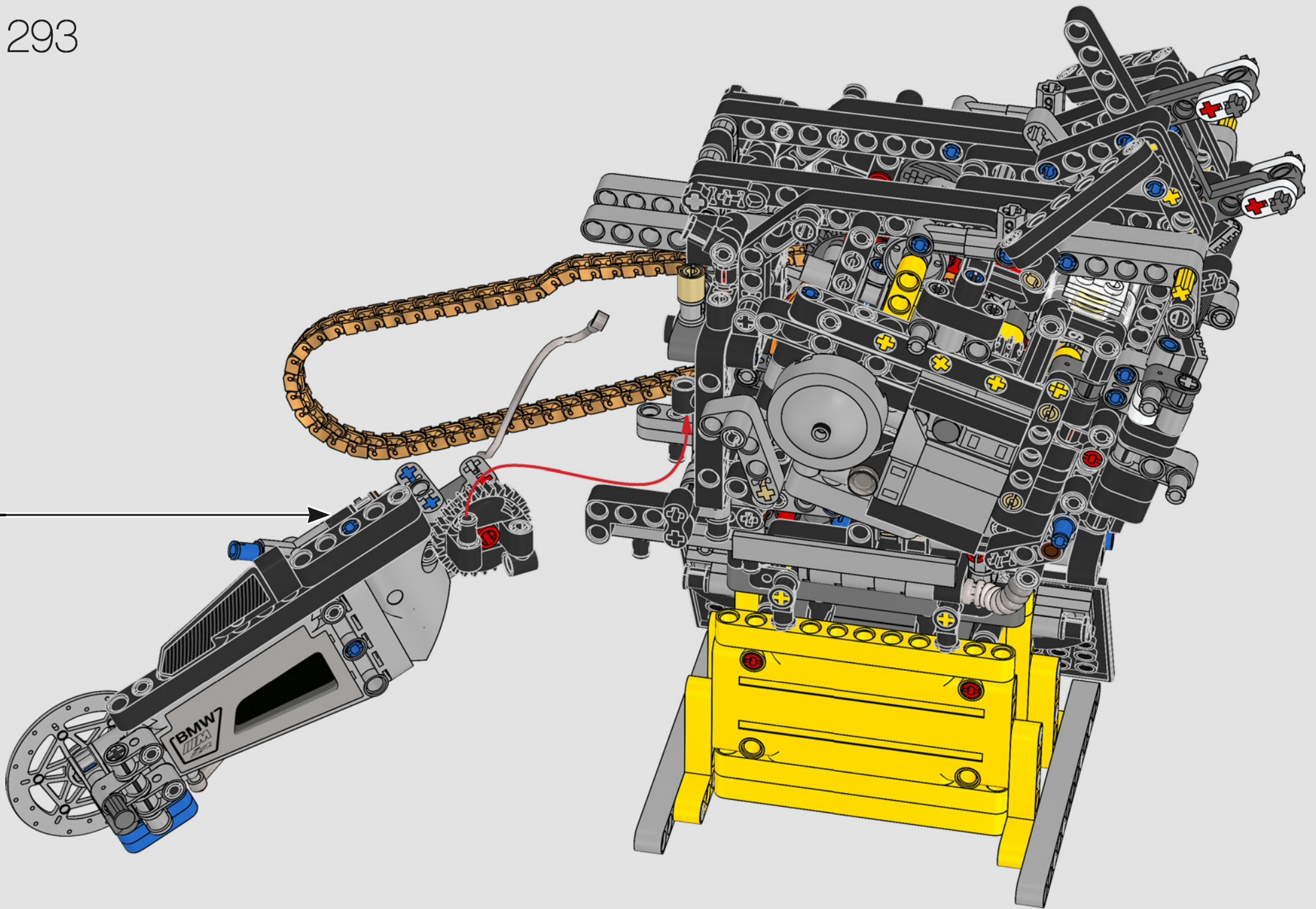

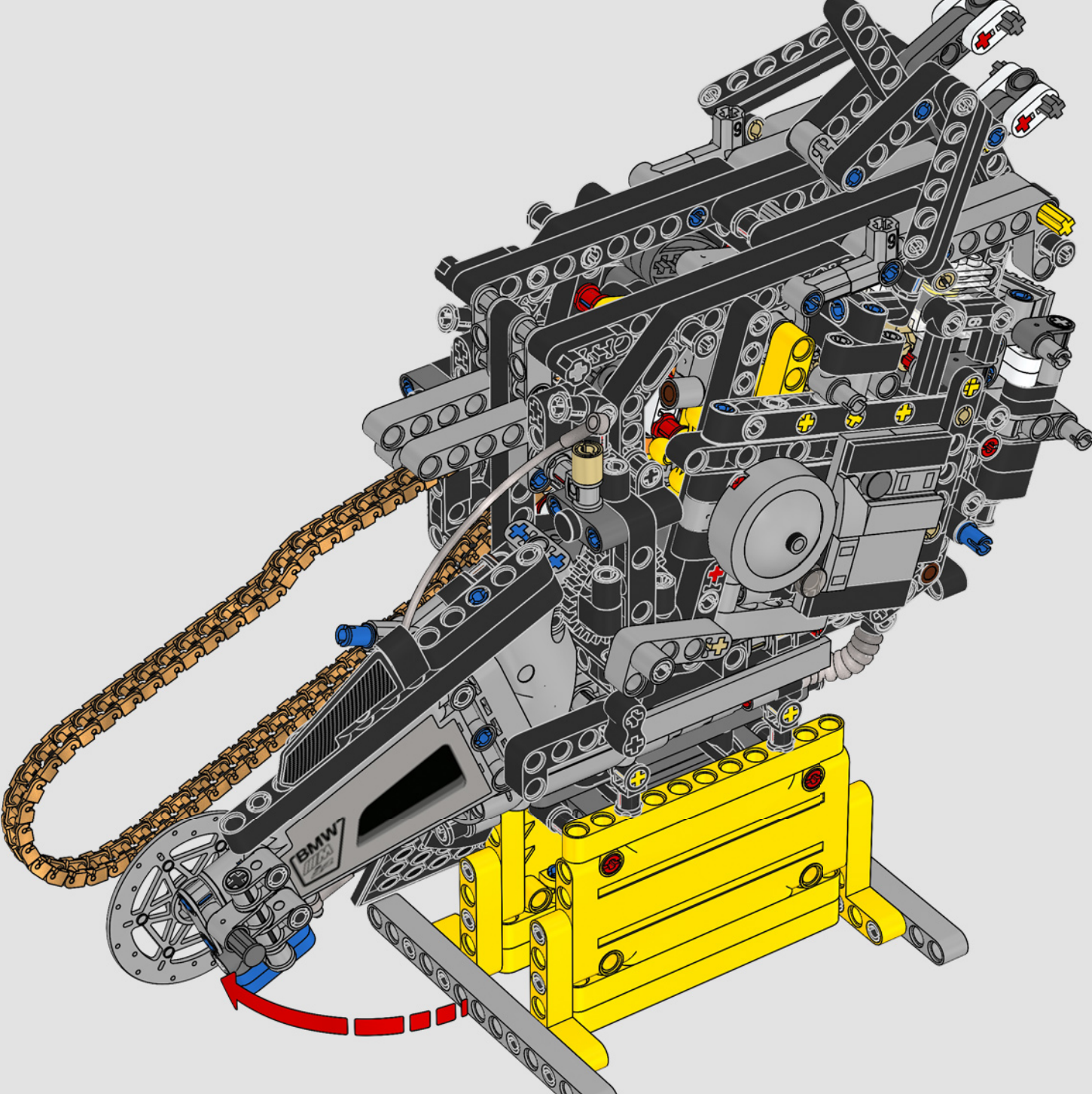

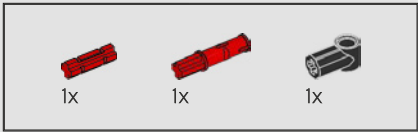

295

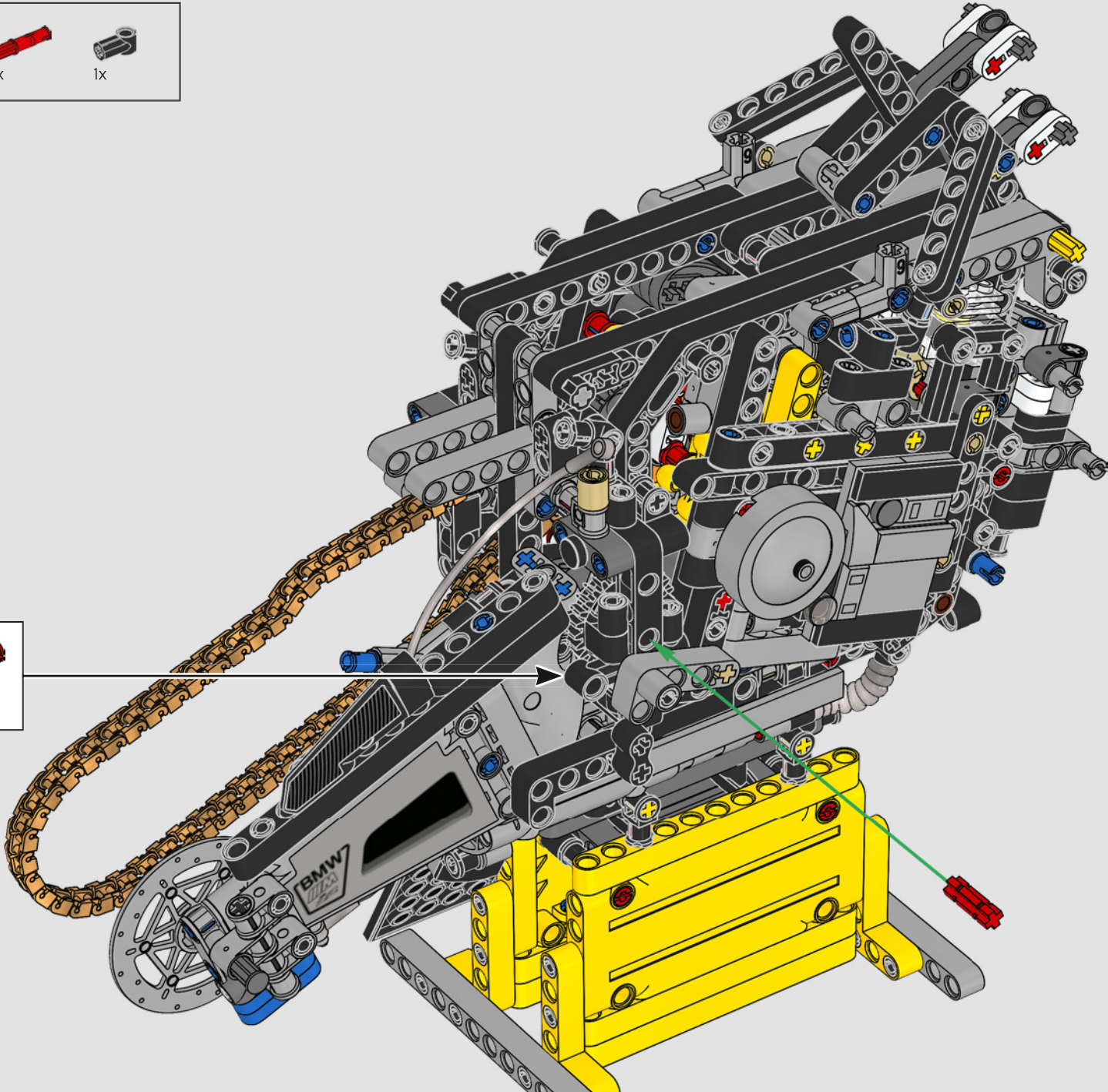
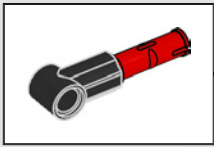

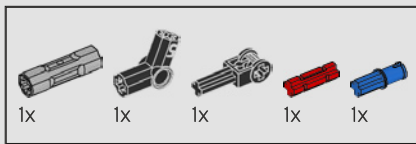

296

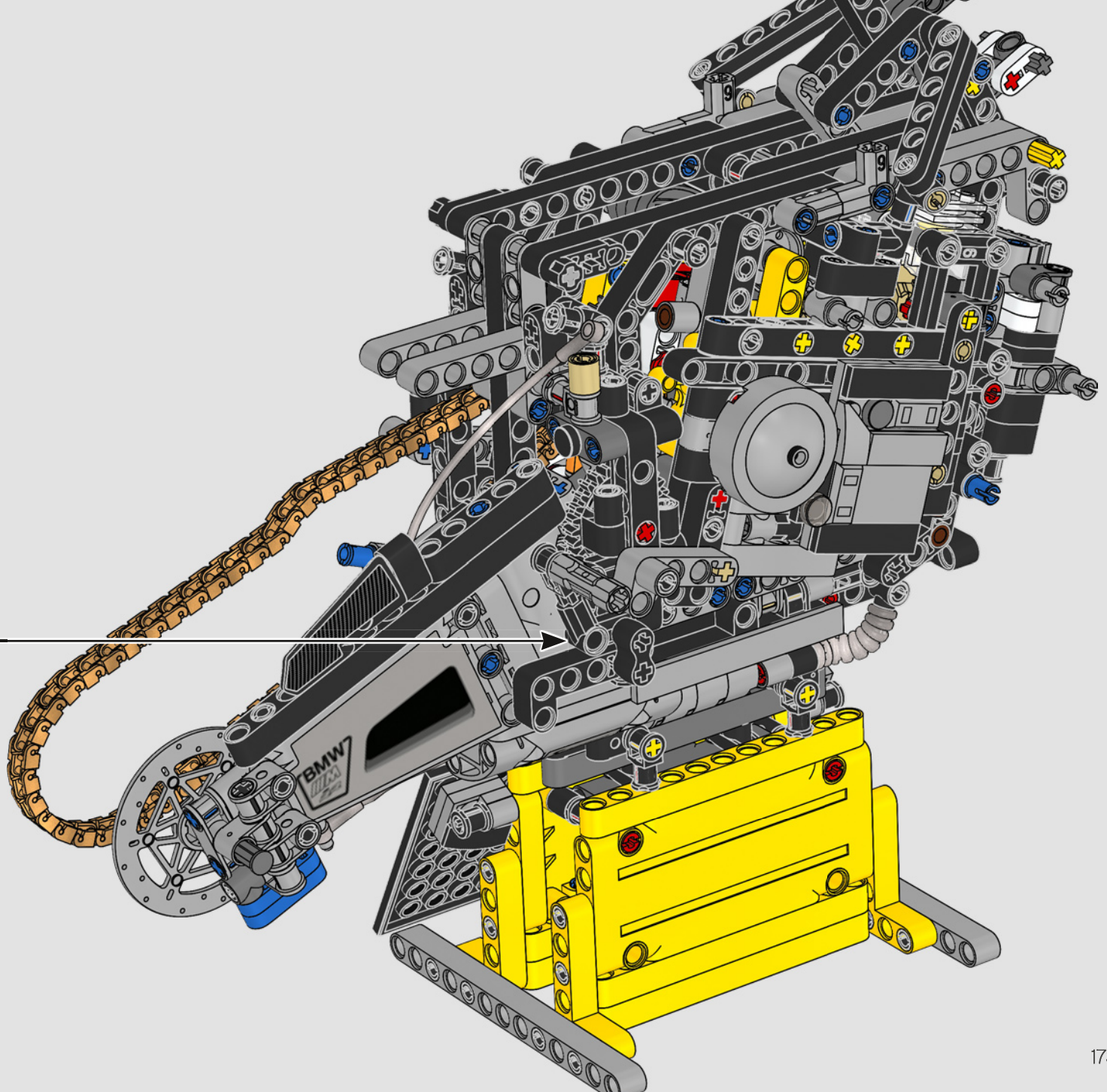
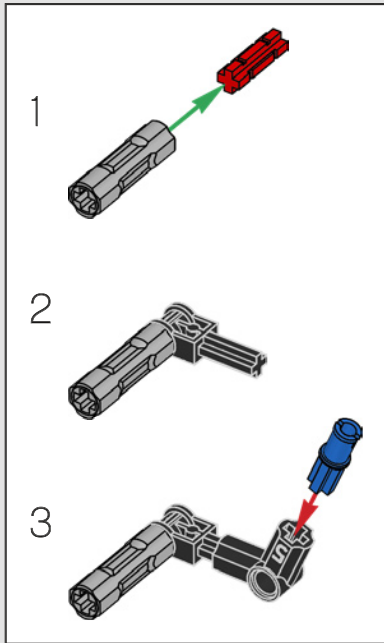

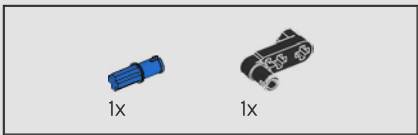

297

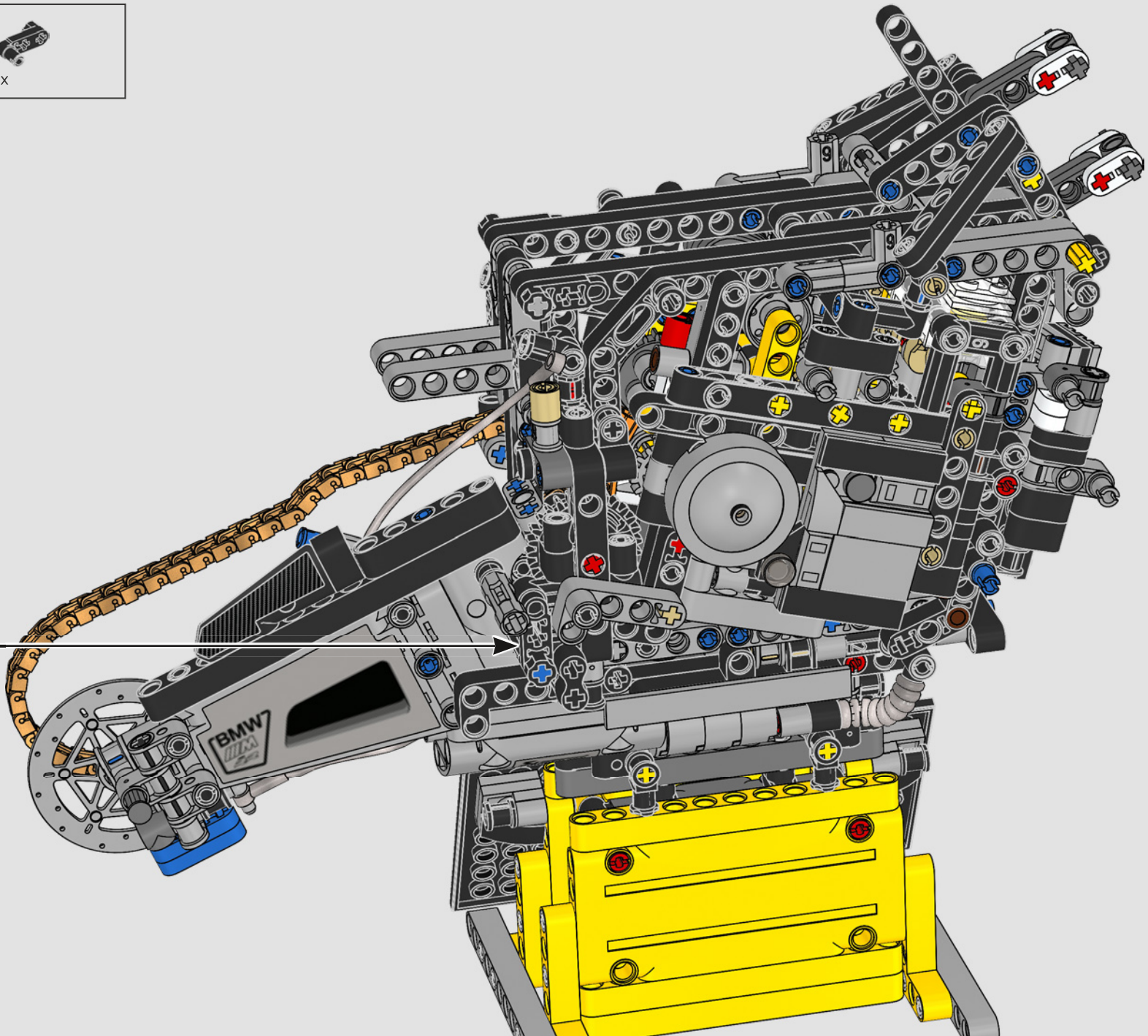
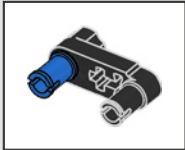

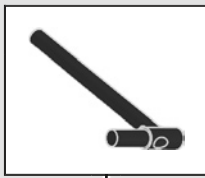
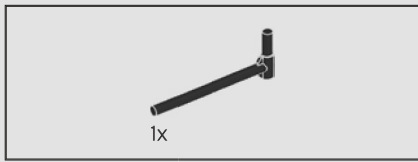

298

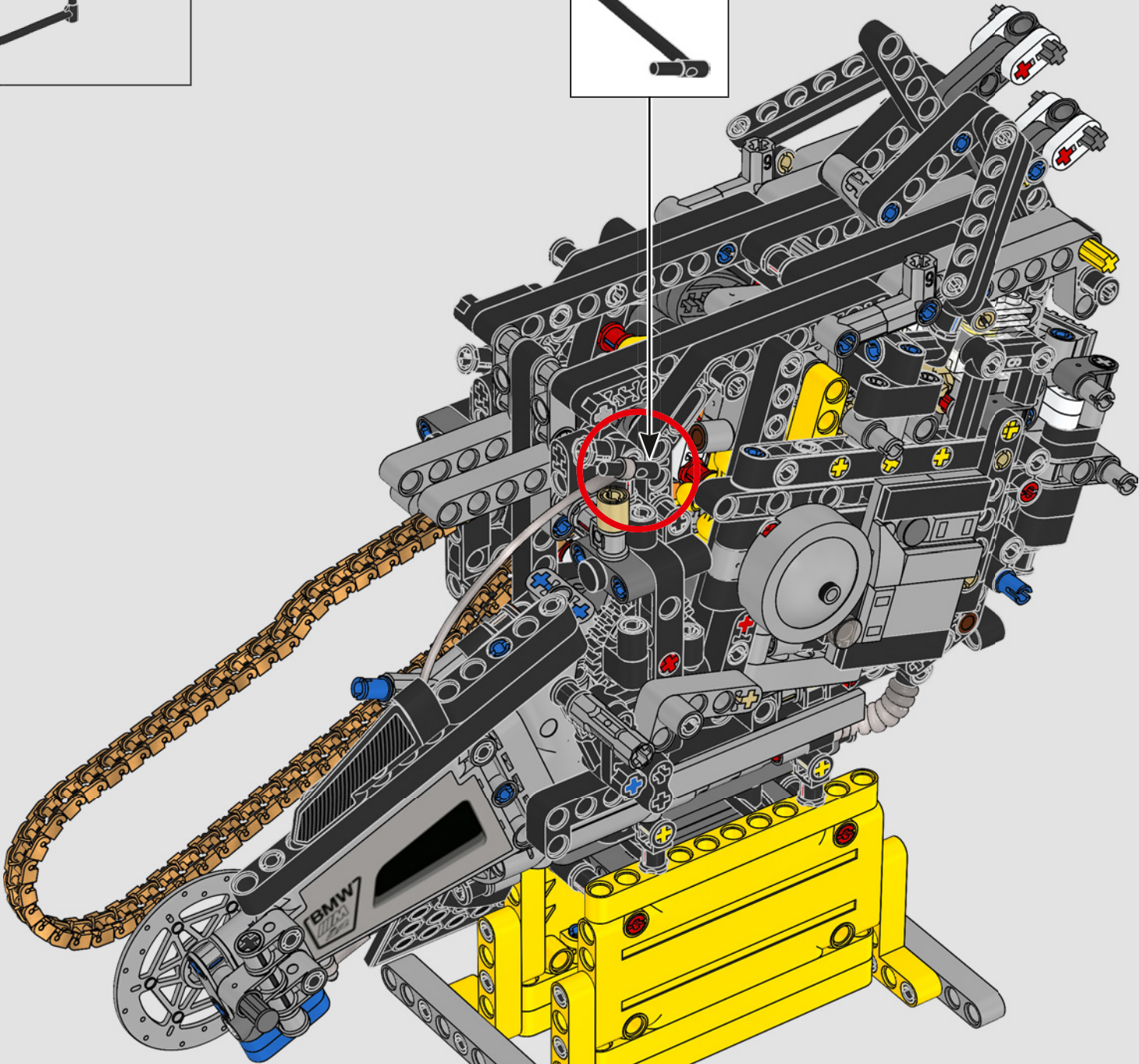

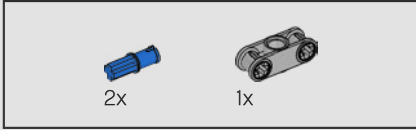
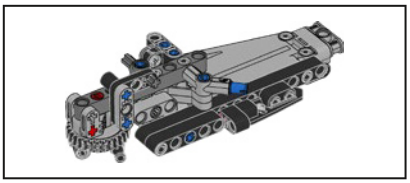

299

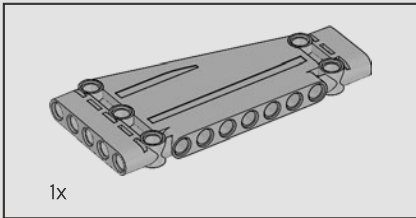
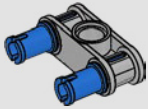

300

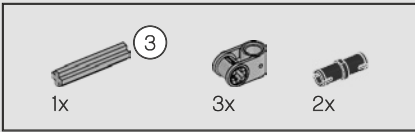
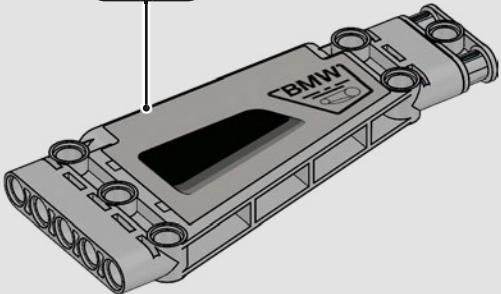

301

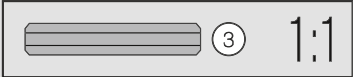
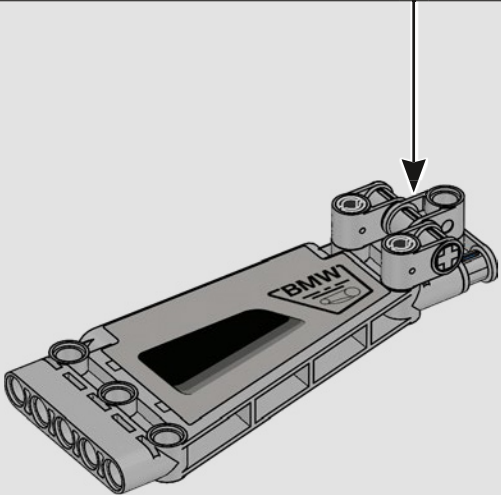
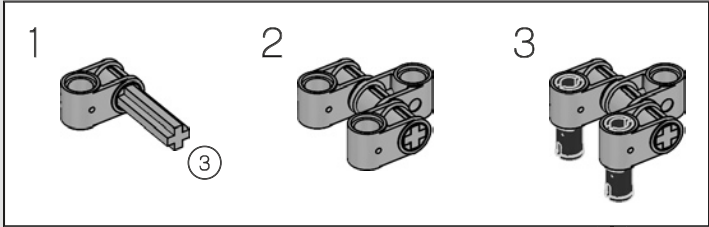

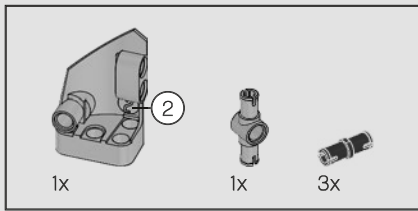

302

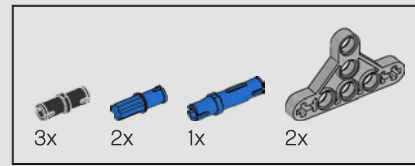
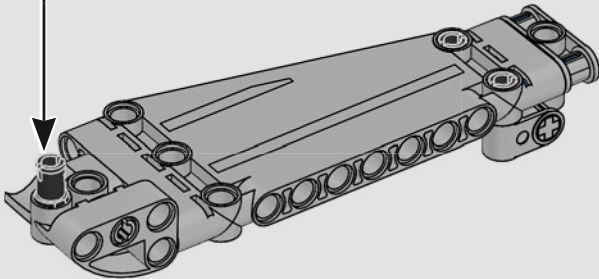
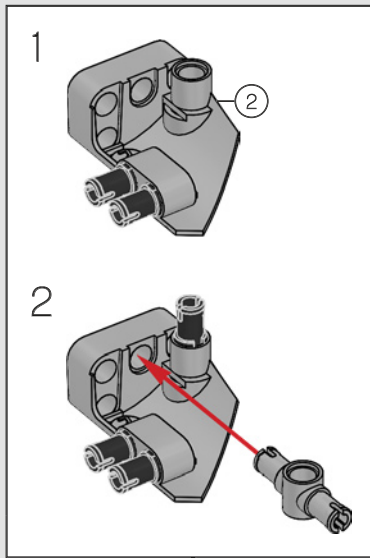

303

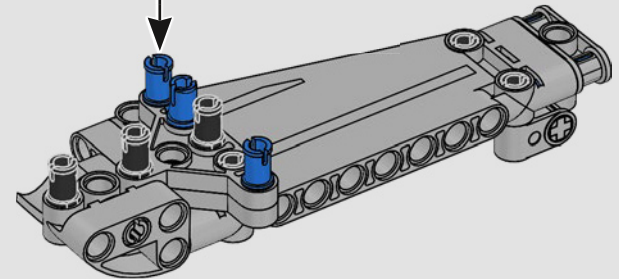
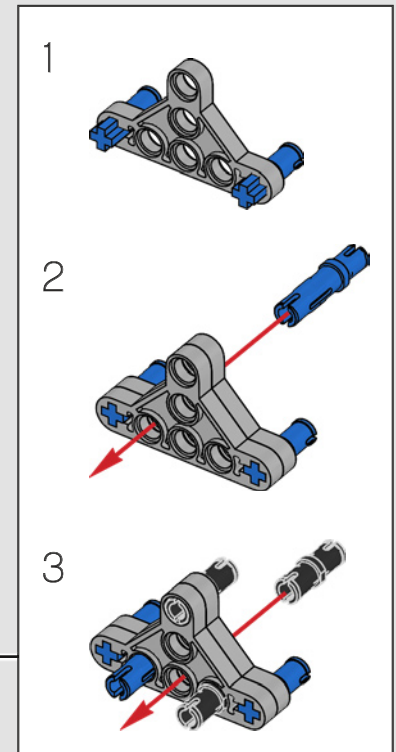

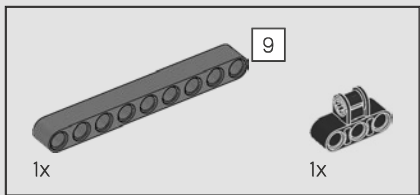

304

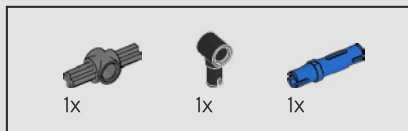
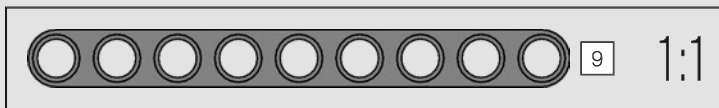
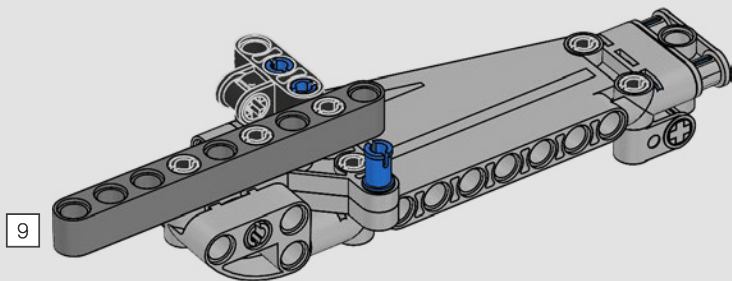

305

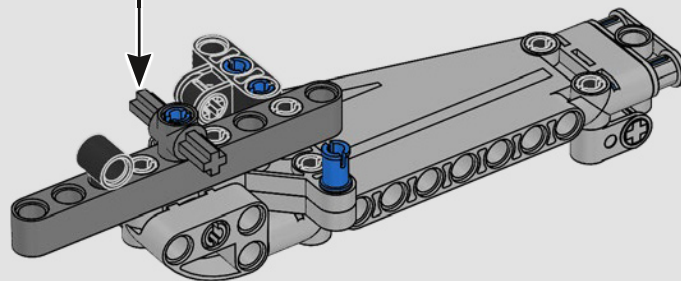
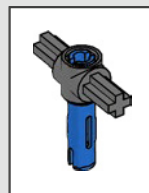

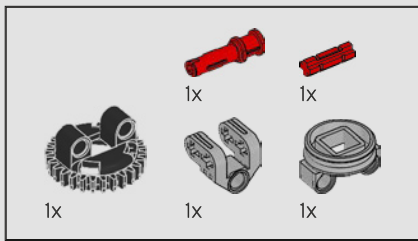

306

1

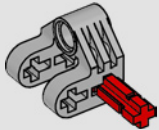

2

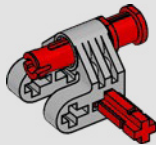

3

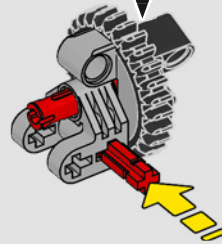

4

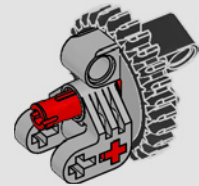

307

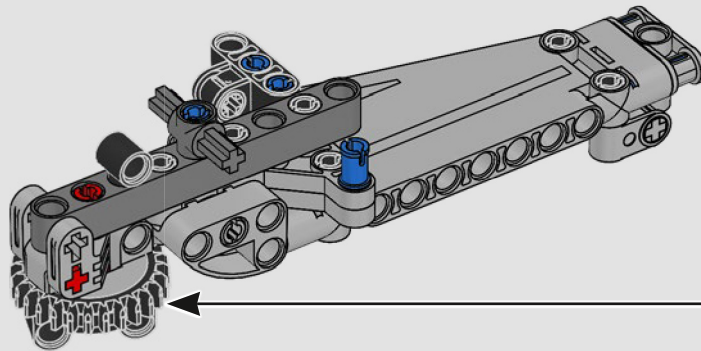

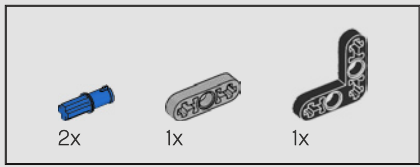

308

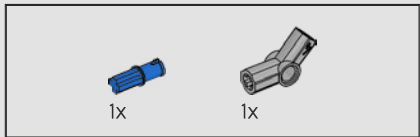
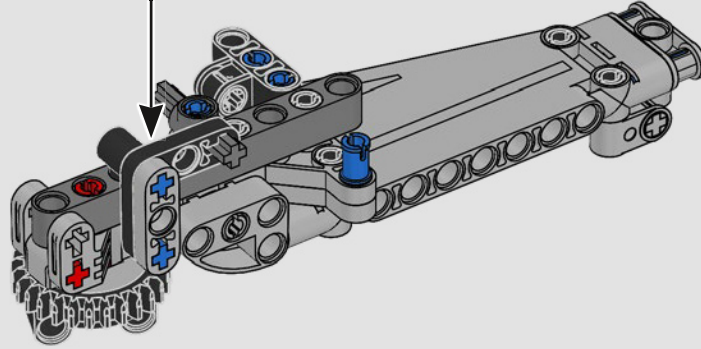
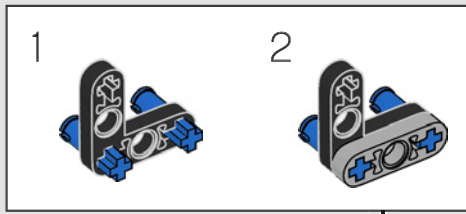

309

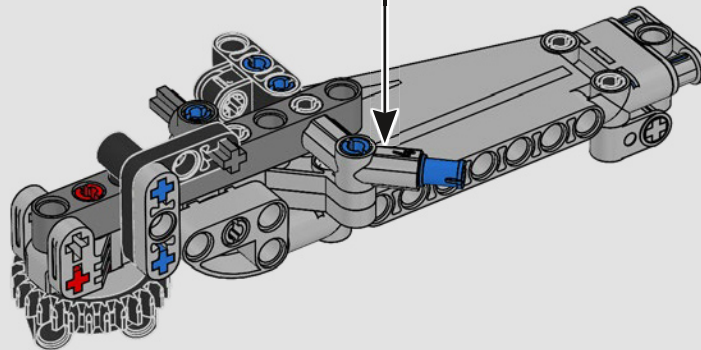
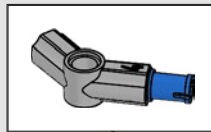

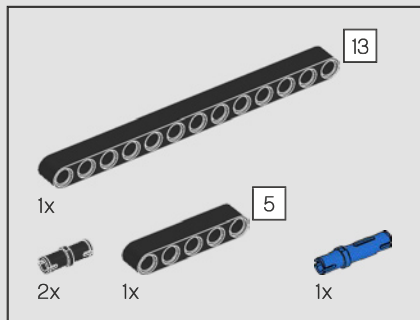

310

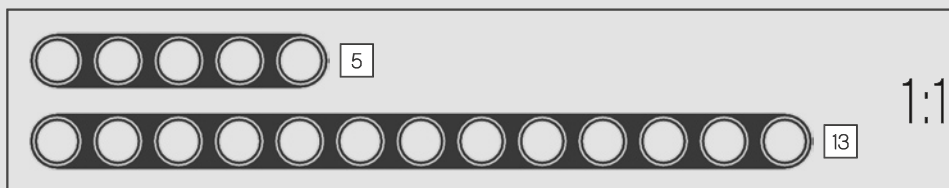
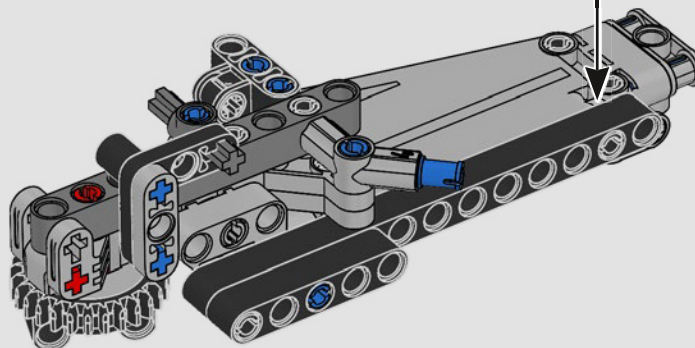
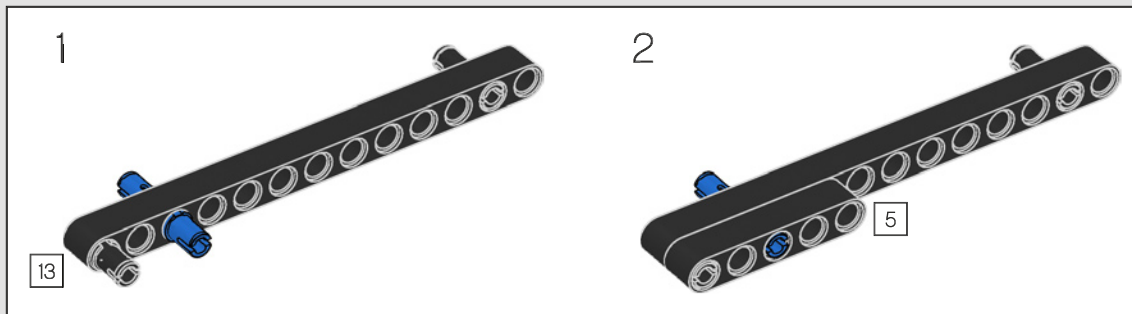

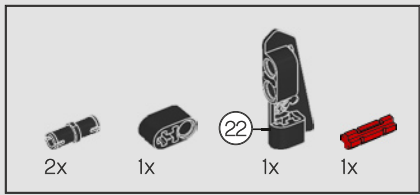

311

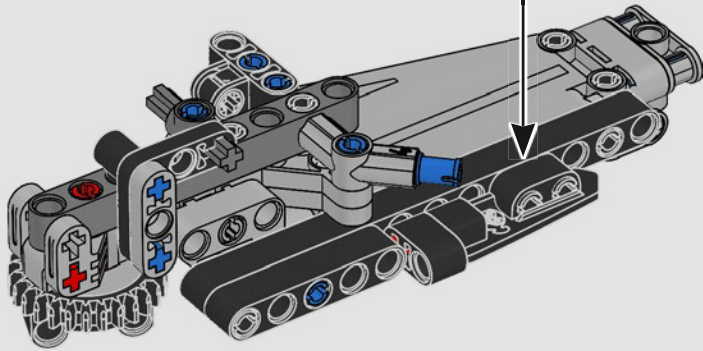
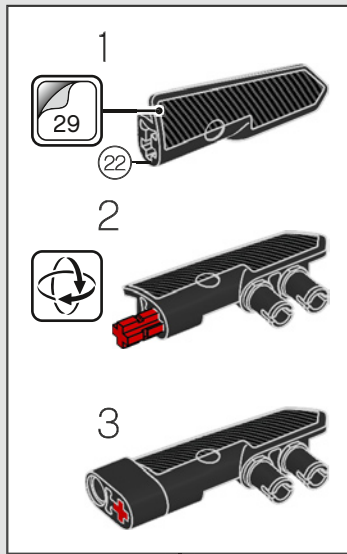

312

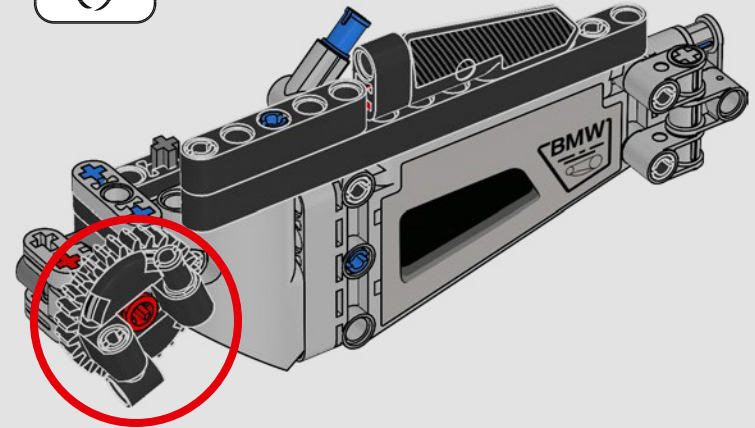
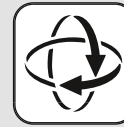

313

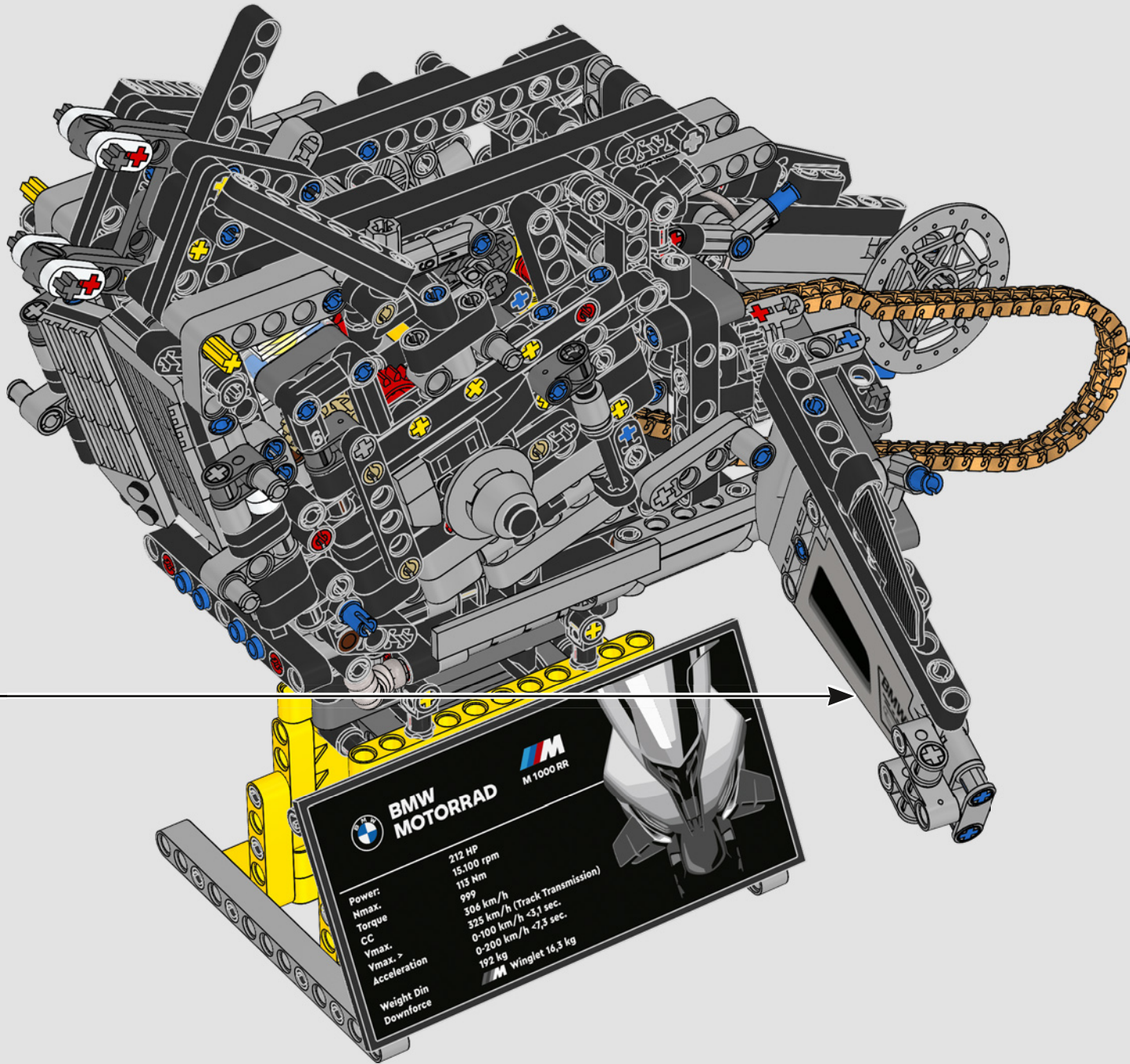

BMW MOTORRAD  **M 1000 RR**

Power:	212 HP
Nmax.	15,100 rpm
Torque	113 Nm
CC	999
Vmax.	306 km/h (Track Transmission)
Vmax. >	325 km/h < 3,1 sec.
Acceleration	0-100 km/h < 7,3 sec.
Weight Din	192 kg
Downforce	Winglet 16,3 kg



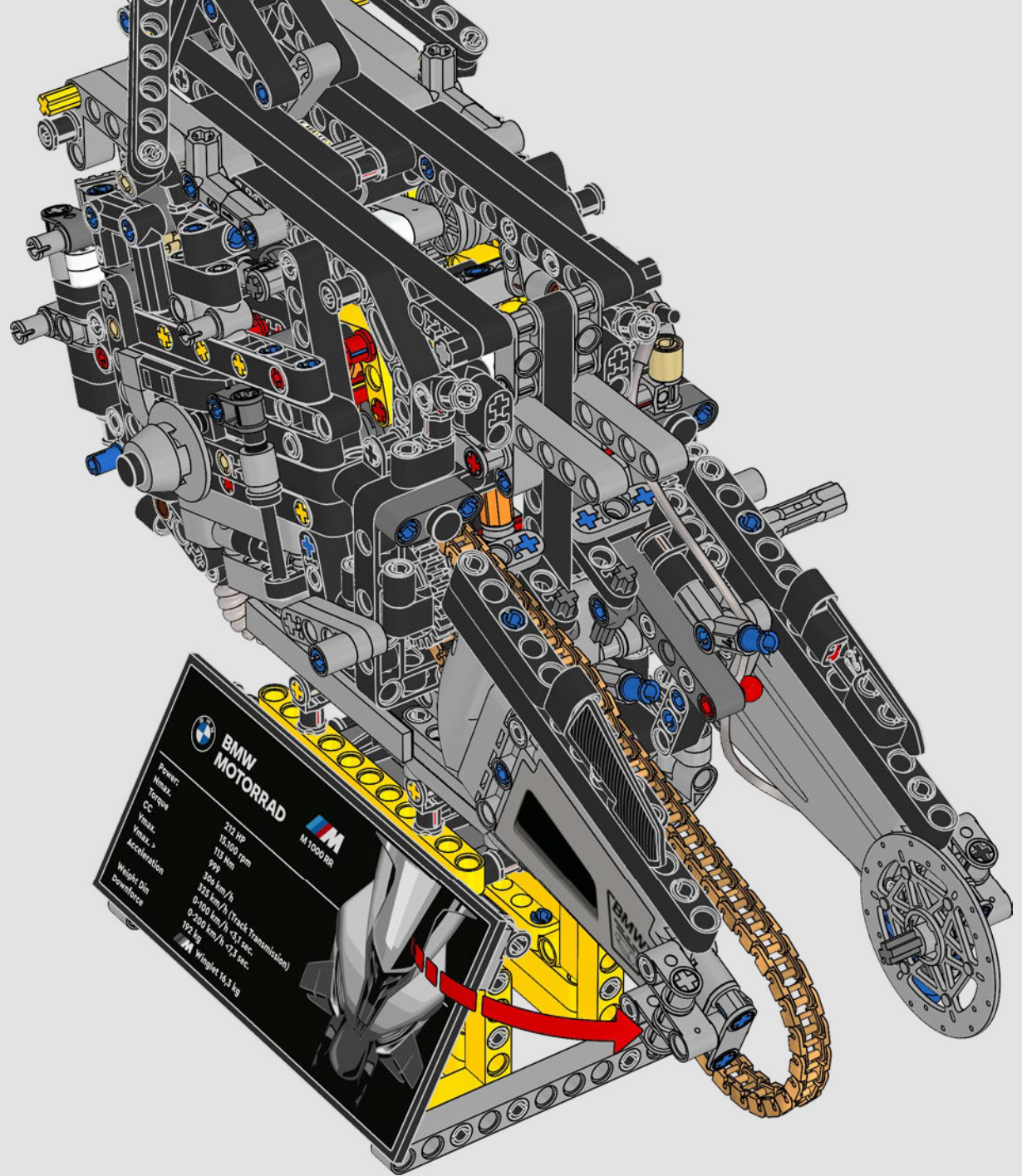
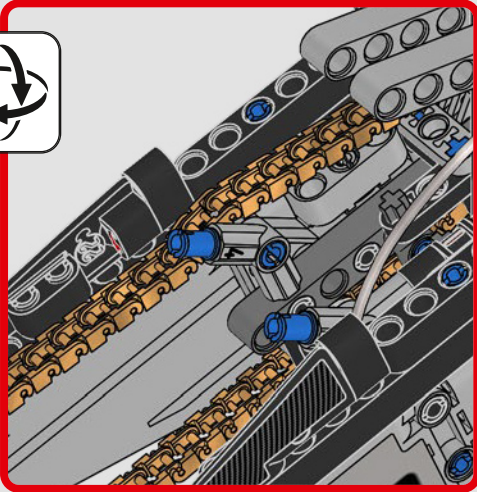

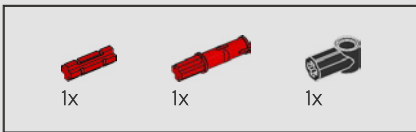

BMW MOTORRAD		M 1000 RR
Power:	212 HP	
Max. Torque:	15,100 rpm	
CC:	113 Nm	
Max. Vmax.:	999	
Acceleration:	356 km/h	
Weight (Dry):	323 km/h (Track Transmission)	
Downforce:	0-100 km/h < 3,1 sec.	
	0-200 km/h < 7,3 sec.	
	192 kg	
	Winglet 16,3 kg	

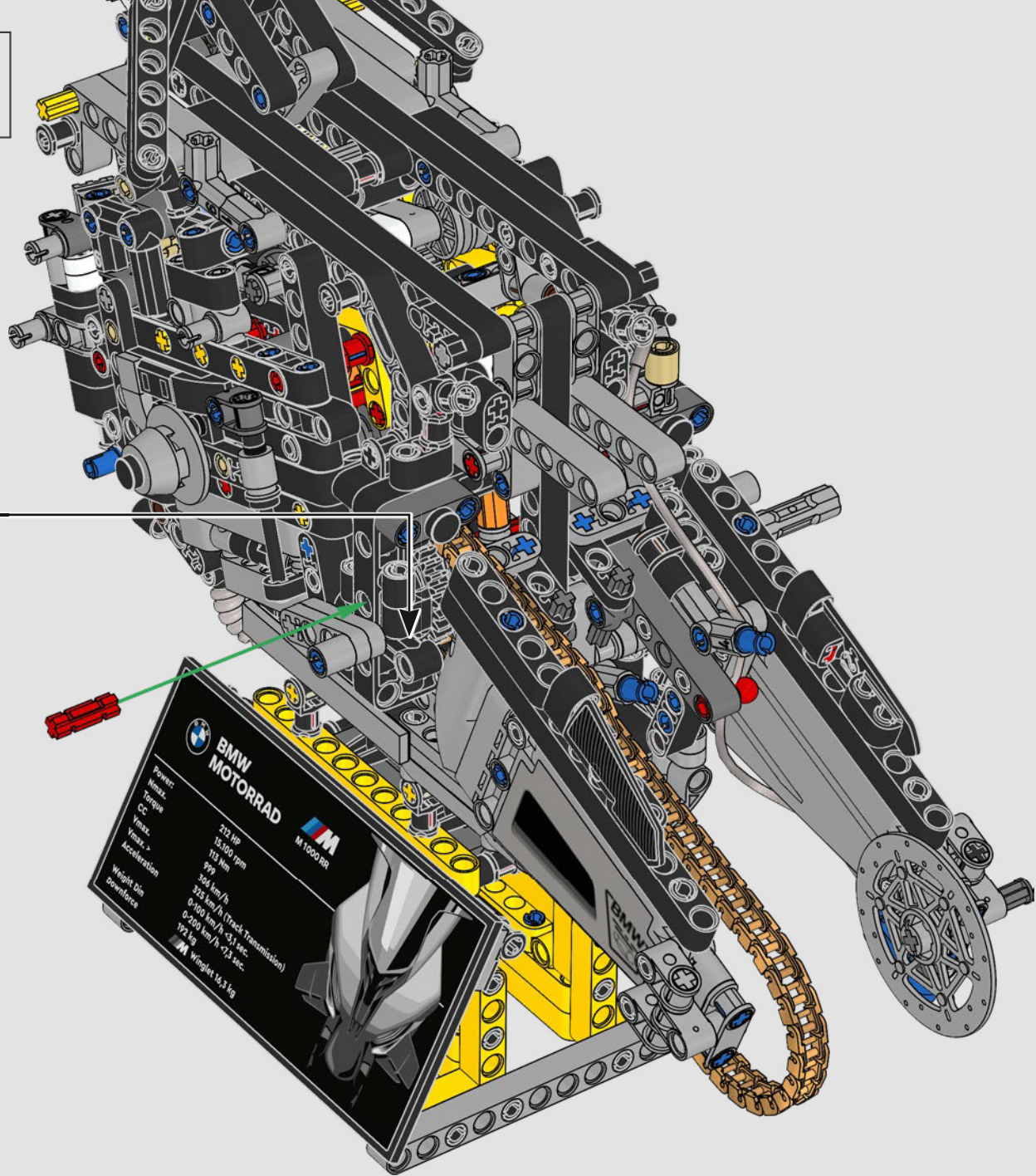
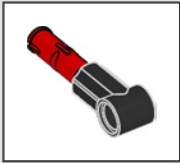

315



BMW MOTORRAD  **M 1000 RR**

Power: 212 hp
 Max. Torque: 15.100 rpm
 CC: 1173 cm³
 Vmax: 304 km/h
 Acceleration: 0-100 km/h <math>< 3.1 \text{ sec.}</math>
 0-200 km/h <math>< 11.3 \text{ sec.}</math>
 Weight (Dry): 192 kg
 Wetweight: 18,3 kg

BMW  **Wingspan 18,3 kg**

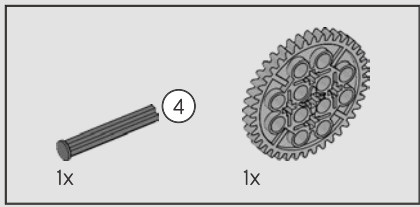

316

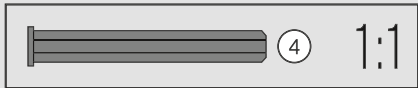
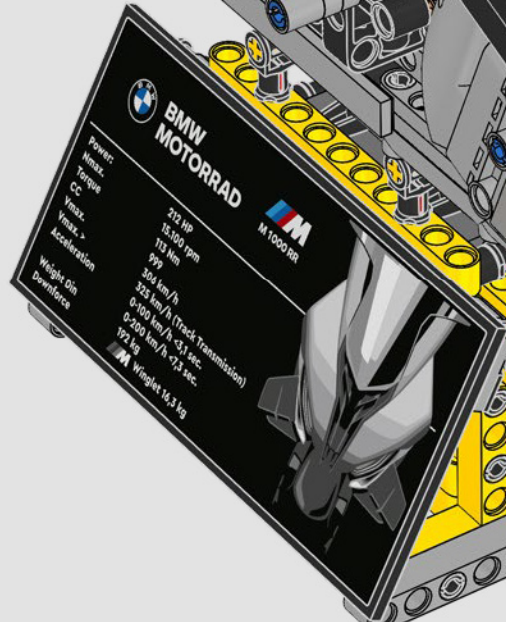
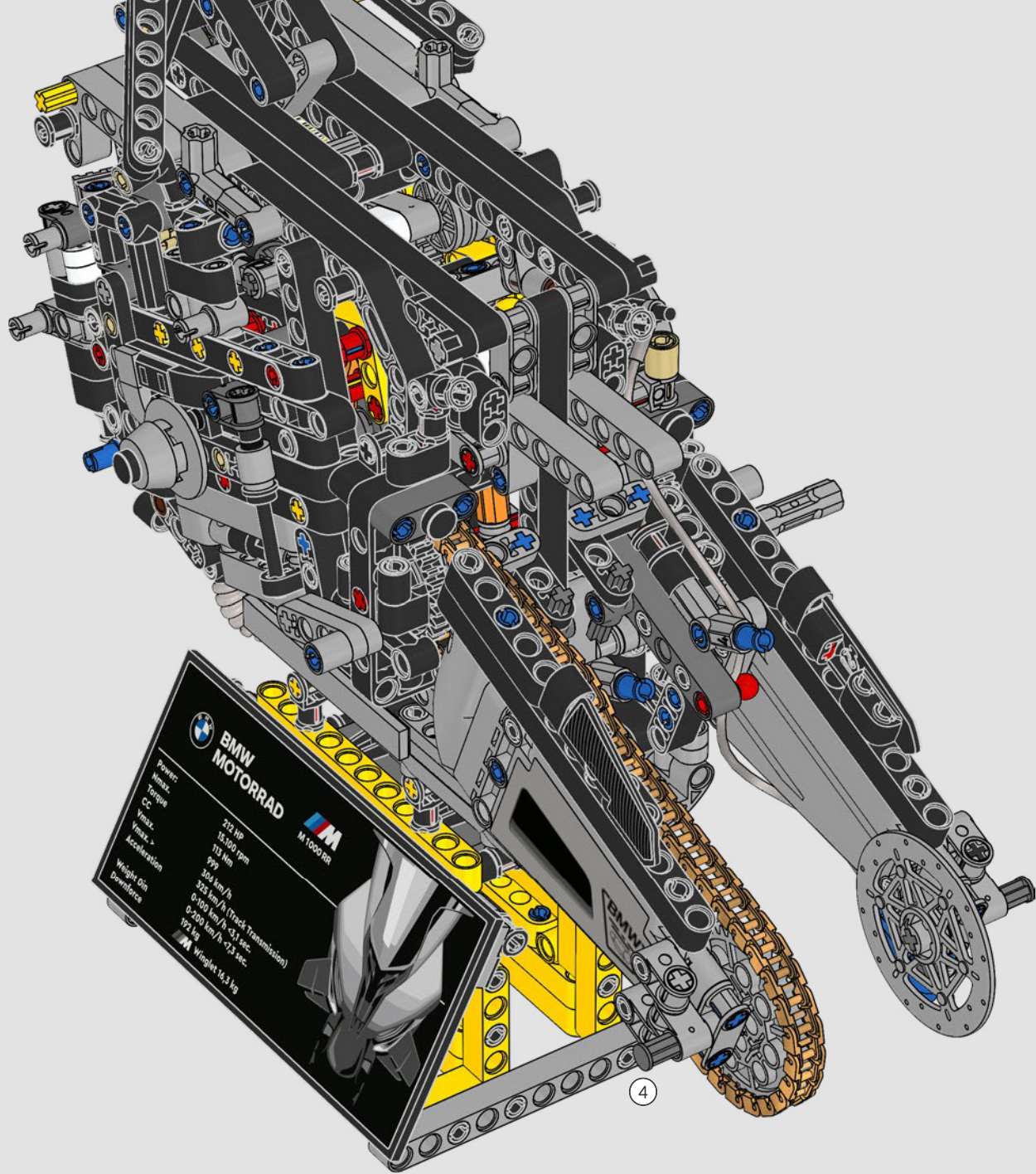

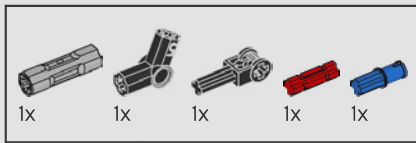

317

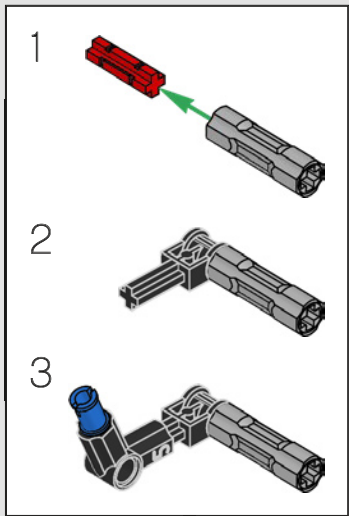
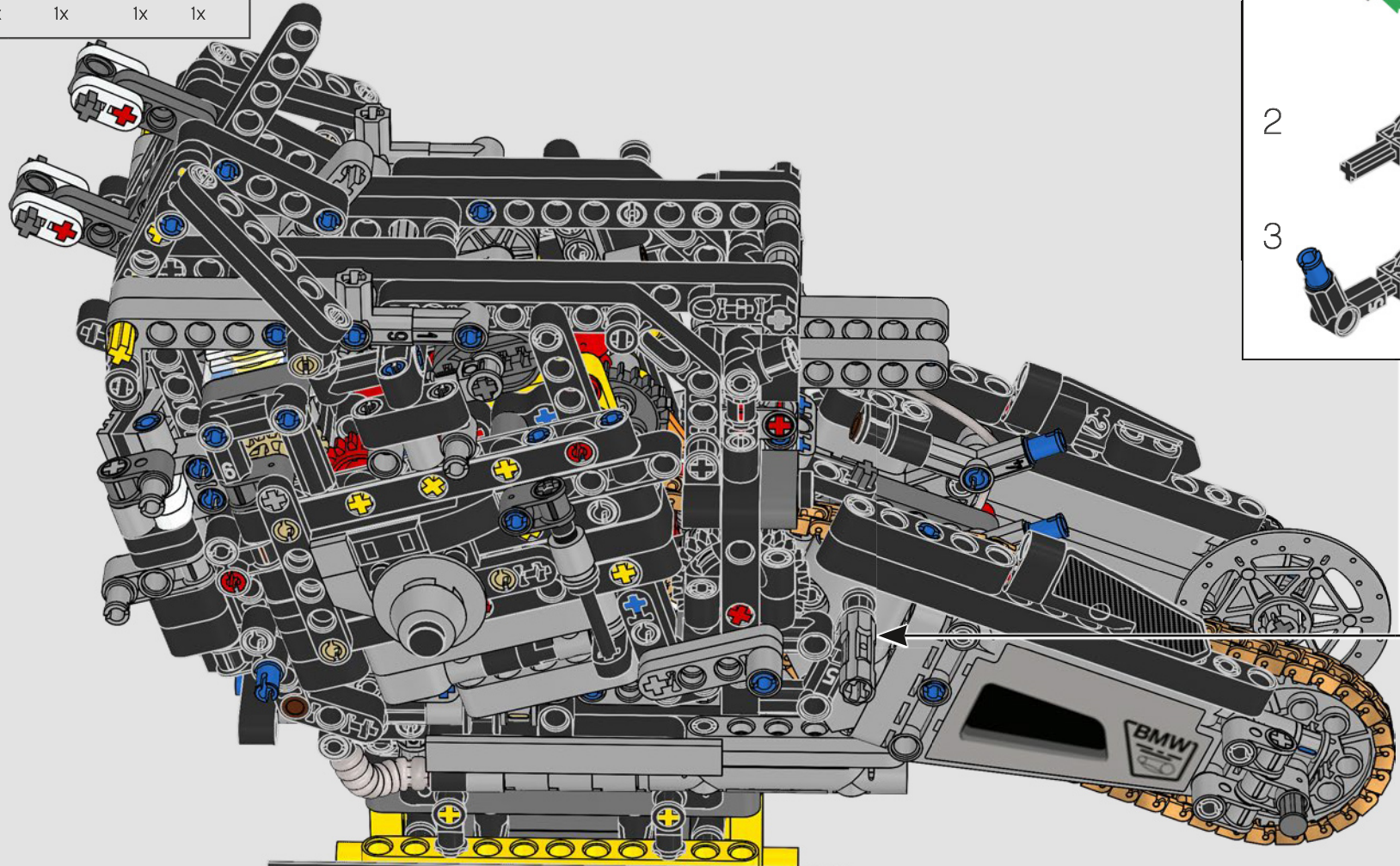



BMW
MOTORRAD



M
M 1000 RR



Power:	212 HP
Nmax.	15,100 rpm
Torque	113 Nm
CC	999
Vmax.	306 km/h
Vmax. >	325 km/h (Track Transmission)
Acceleration	0-100 km/h <3,1 sec.
	0-200 km/h <7,3 sec.
Weight Din	192 kg
Downforce	Winglet 16,3 kg

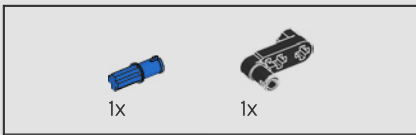

318

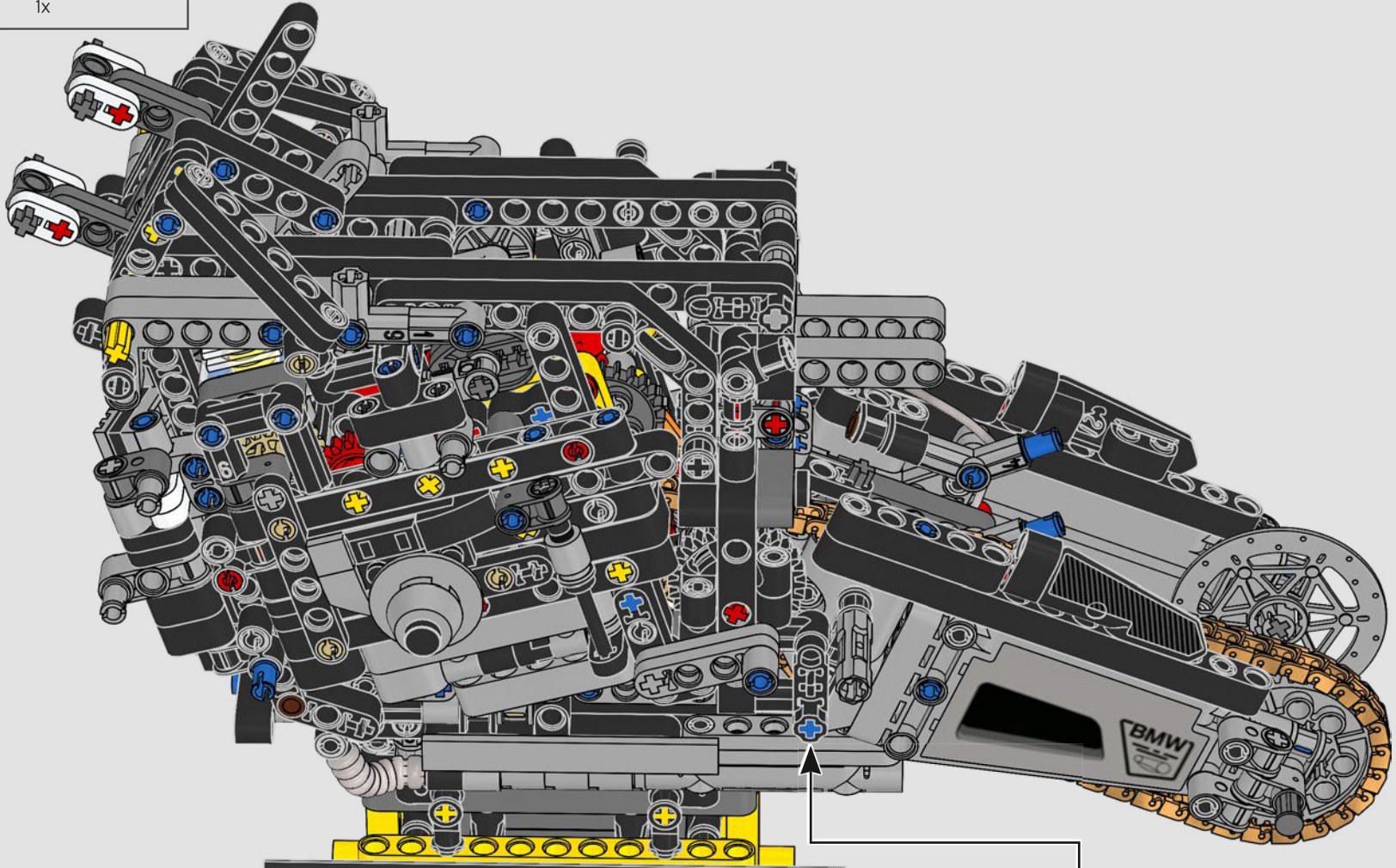



BMW
MOTORRAD



M
1000 RR

Power:	212 HP
Nmax.	15.100 rpm
Torque	113 Nm
CC	999
Vmax.	306 km/h
Vmax. >	325 km/h (Track Transmission)
Acceleration	0-100 km/h <3,1 sec.
	0-200 km/h <7,3 sec.
Weight Din	192 kg
Downforce	Winglet 16,3 kg

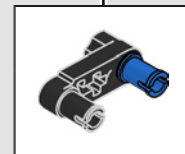

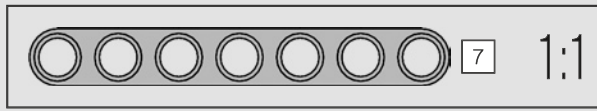
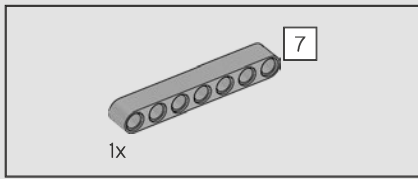
319



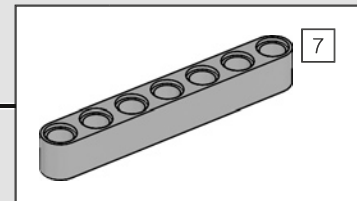
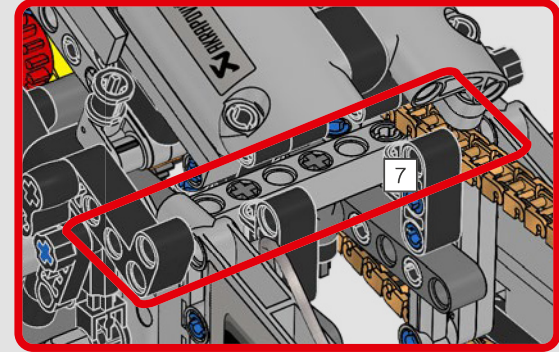
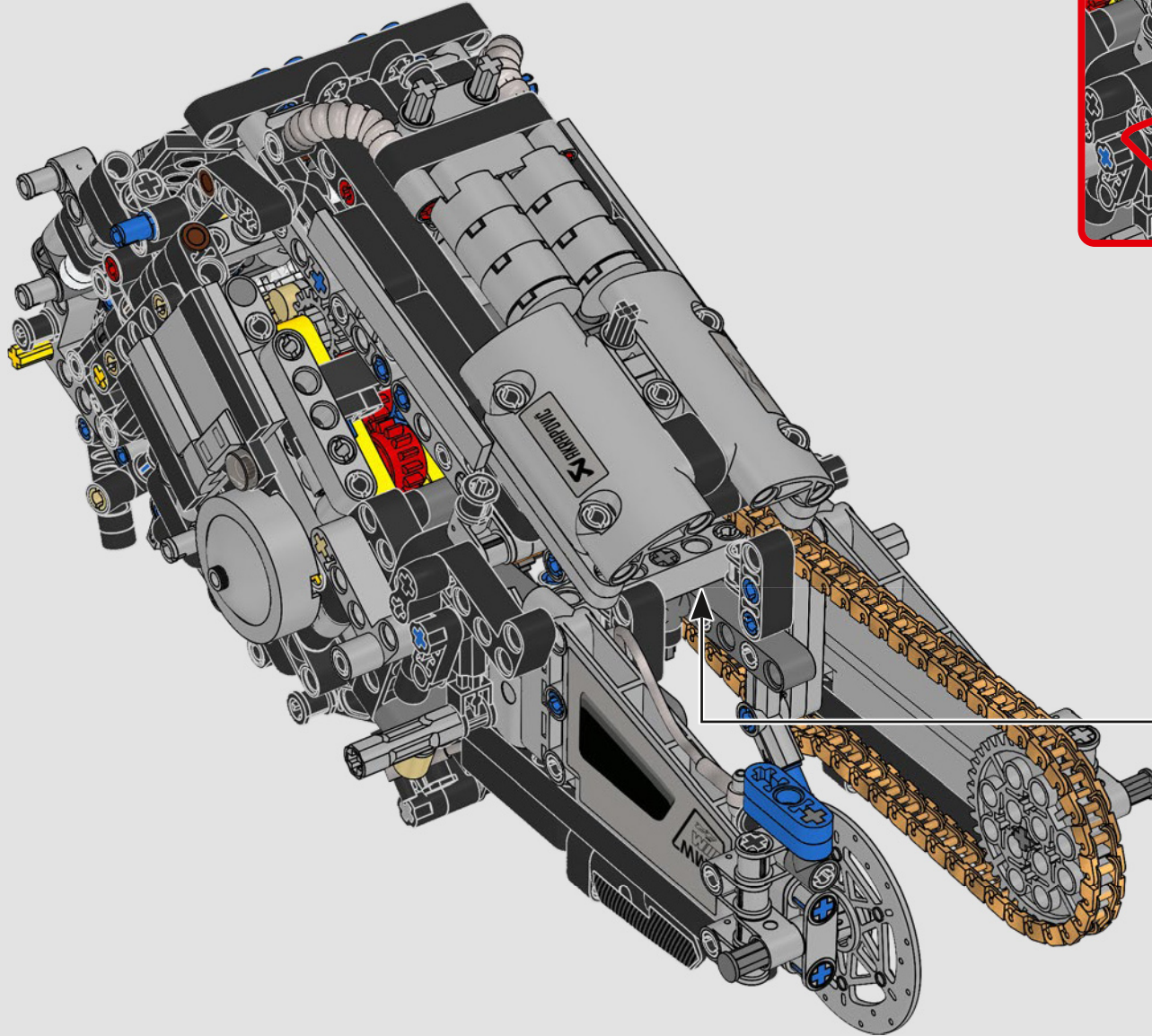

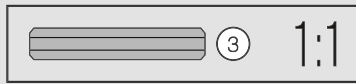
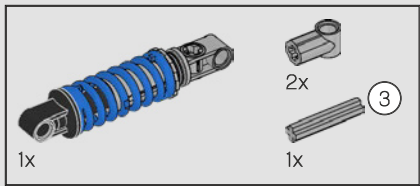
320

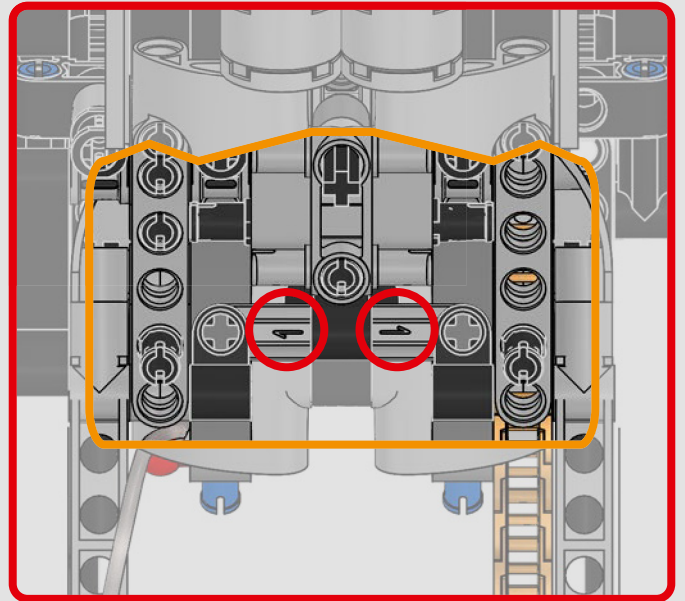
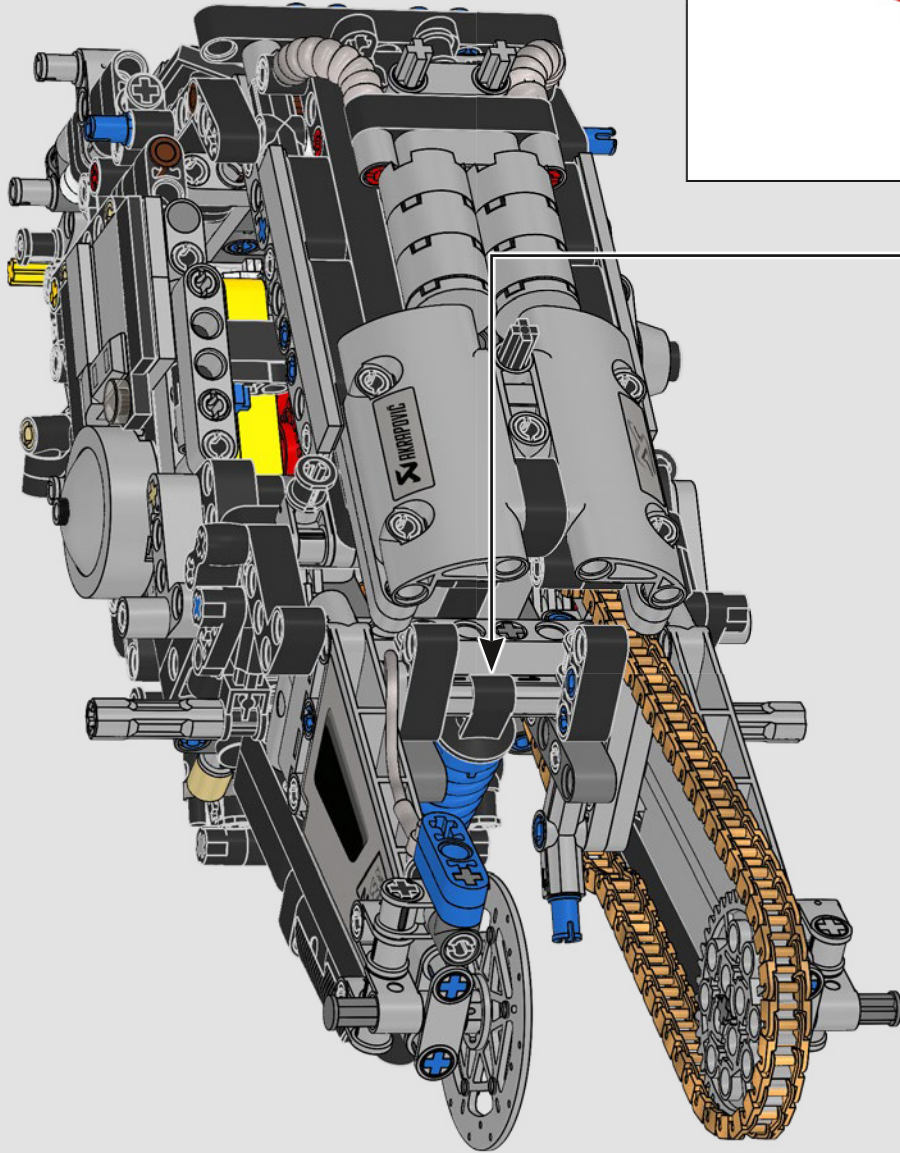
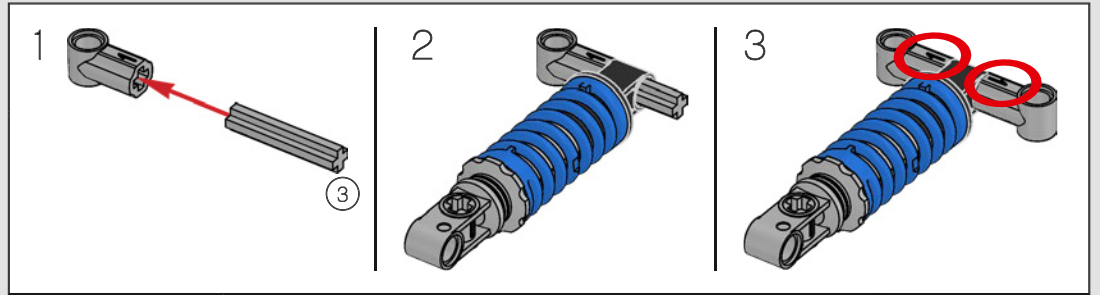

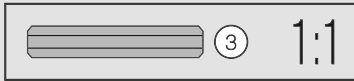
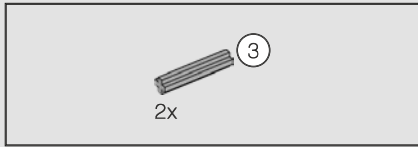

321

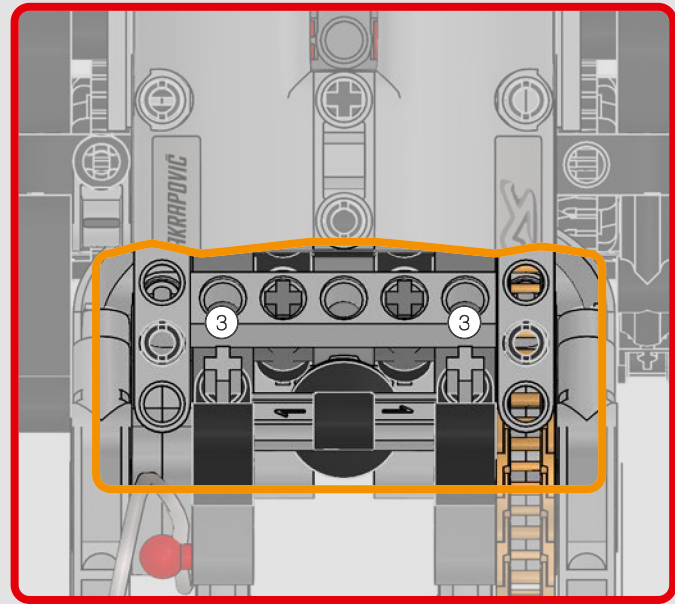
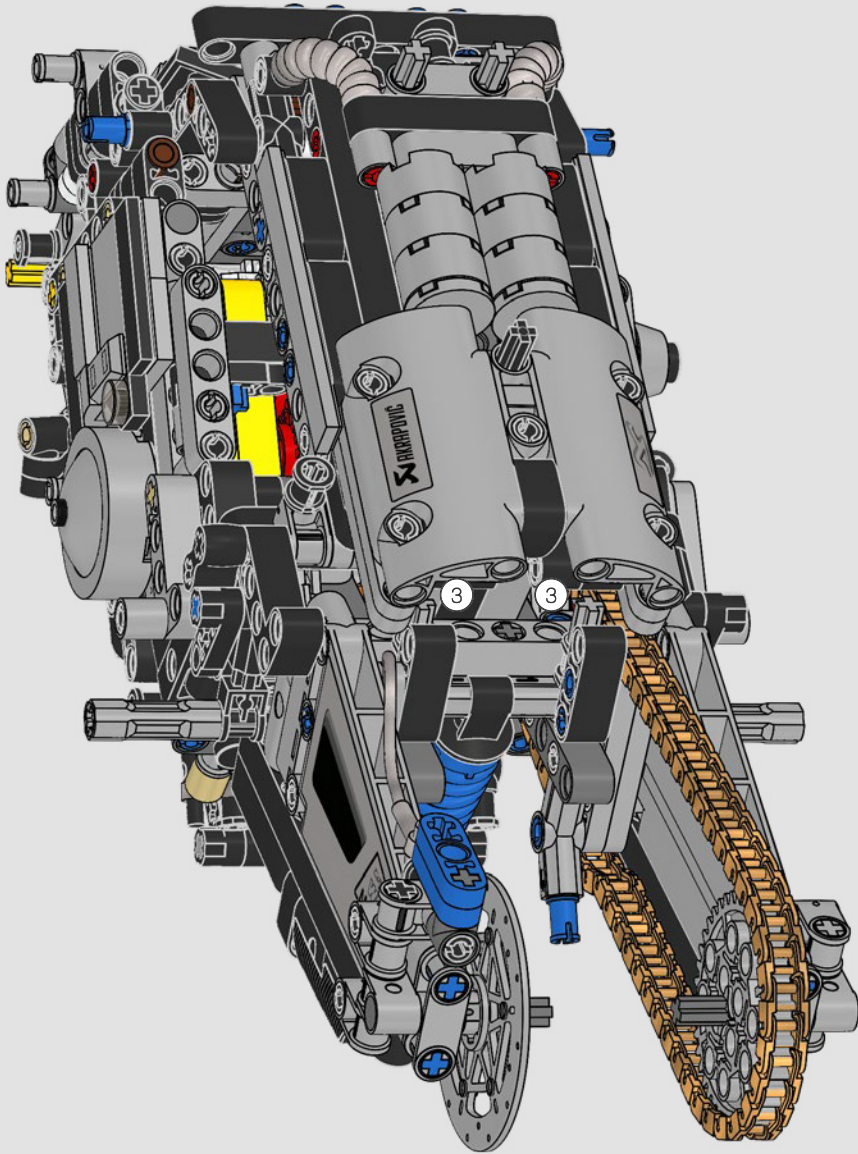

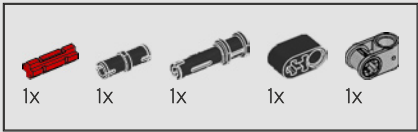

322

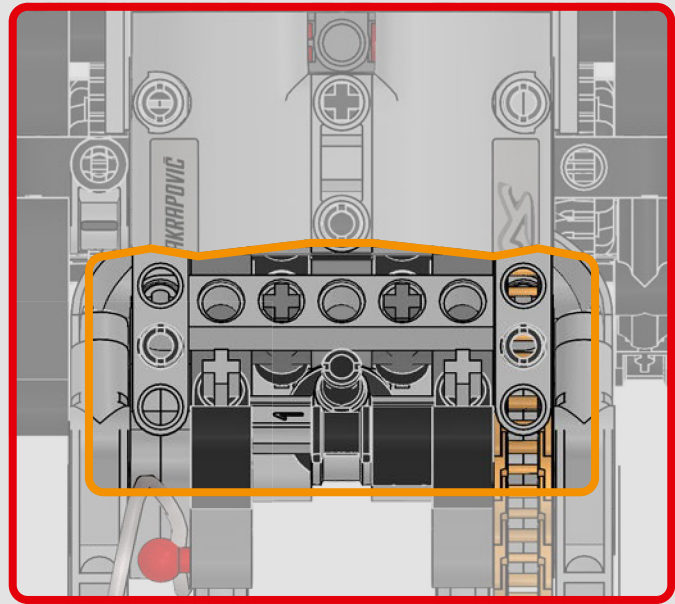
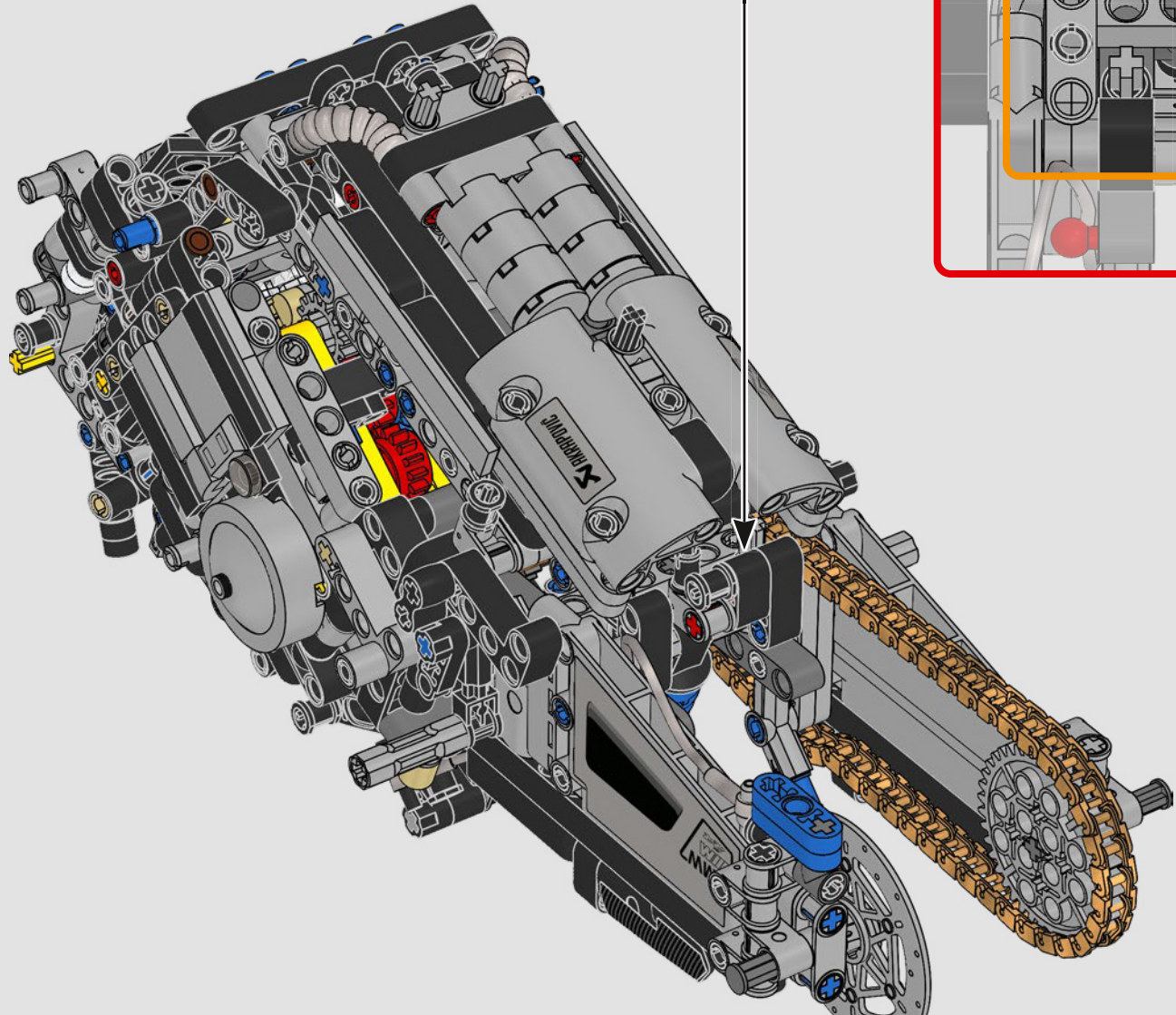
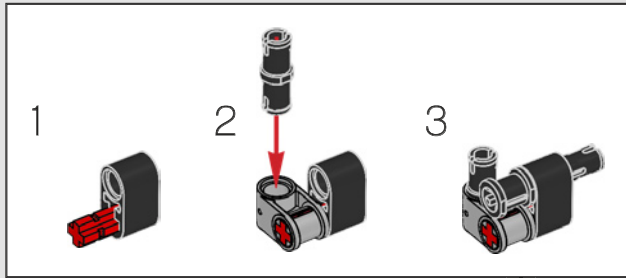

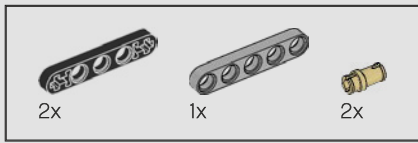

323

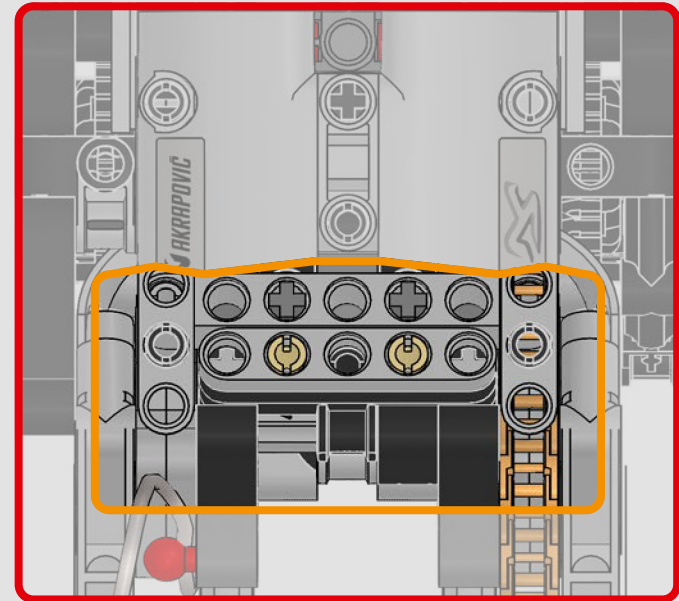
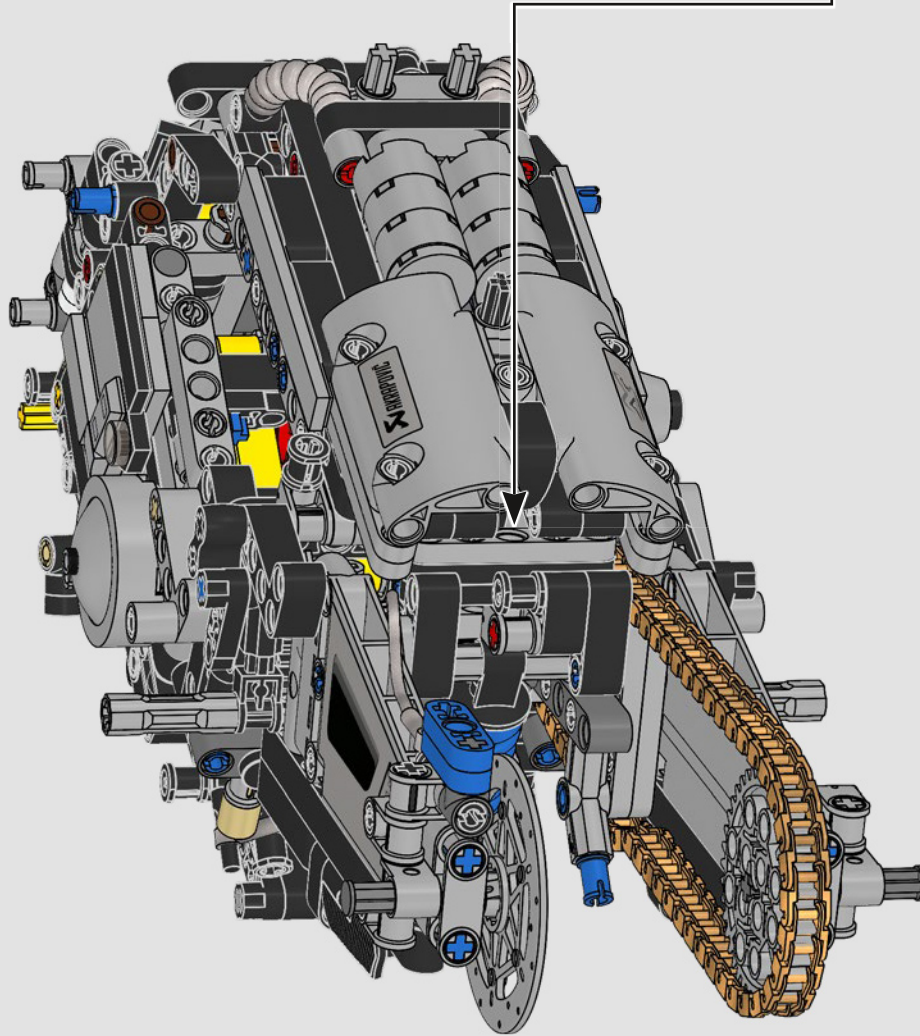
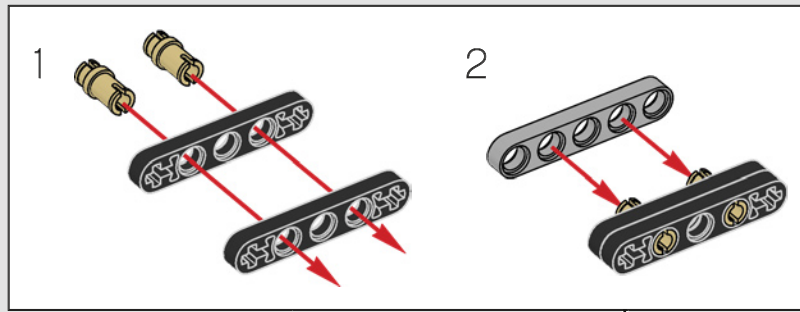

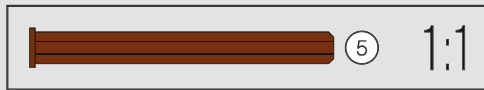
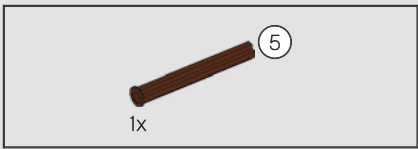

324

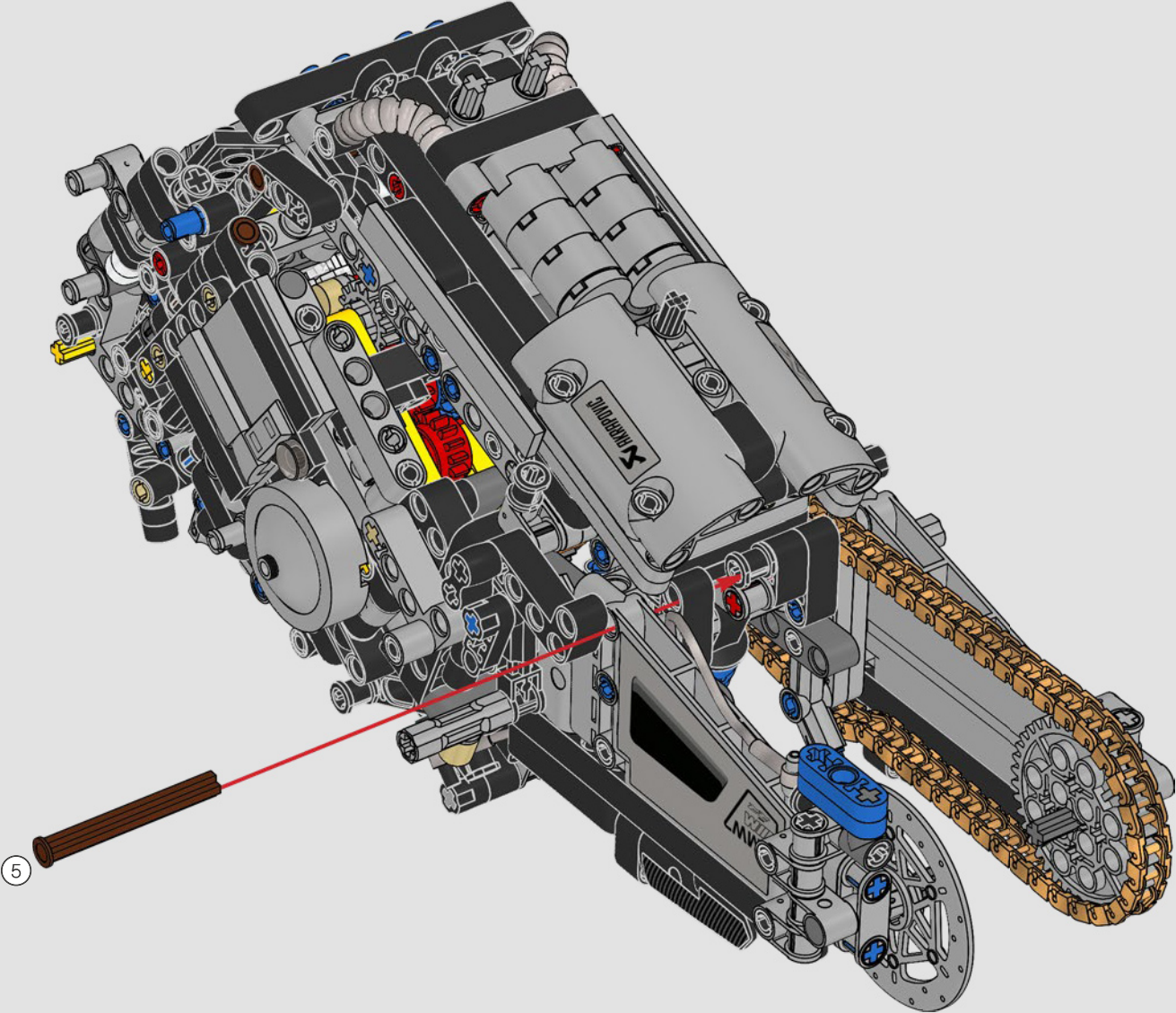

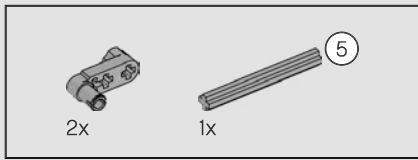

325

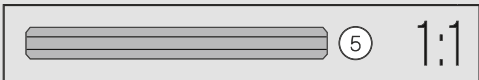
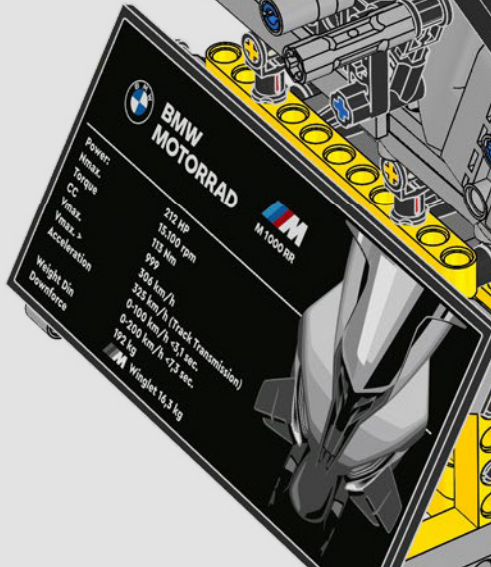
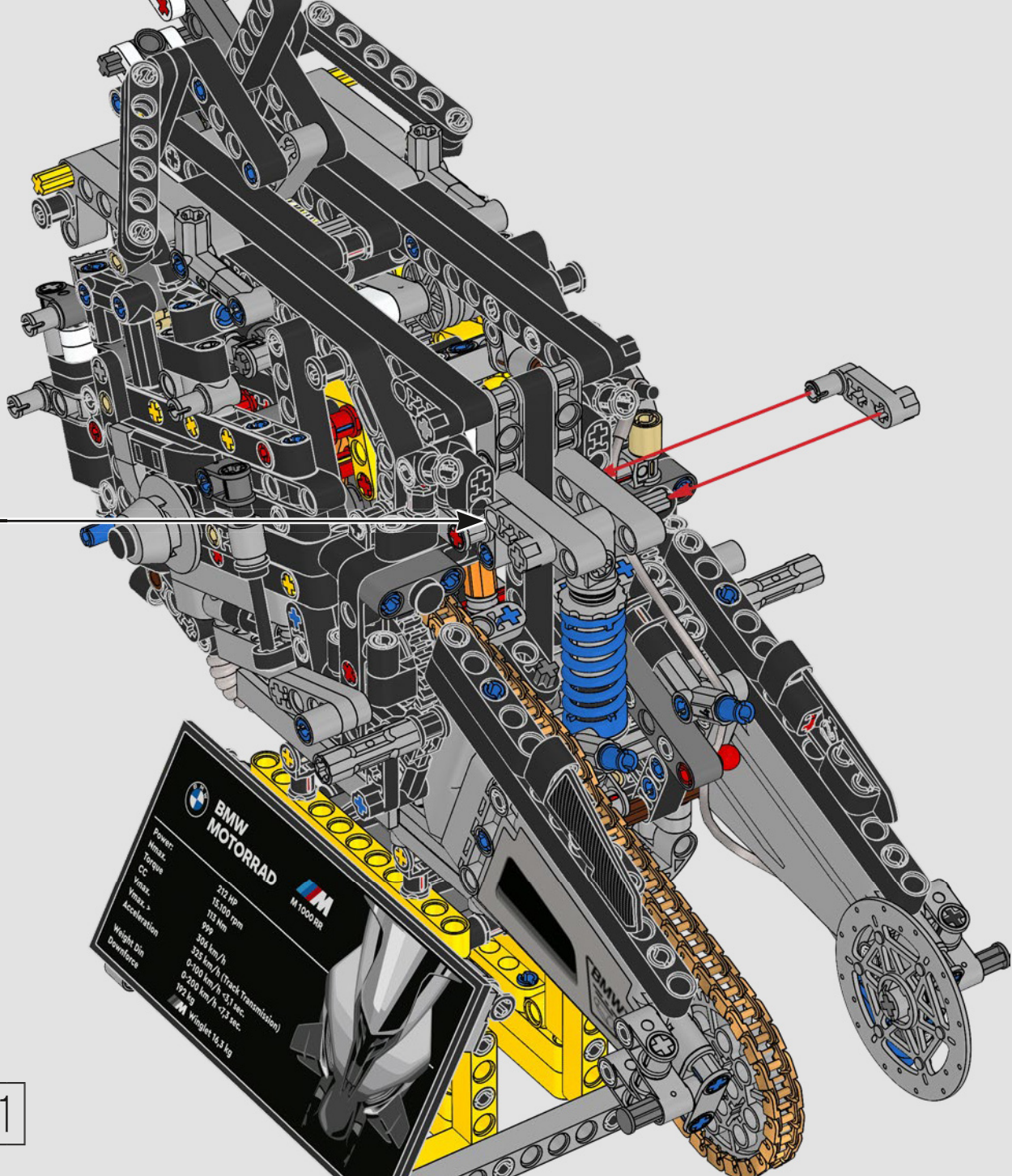
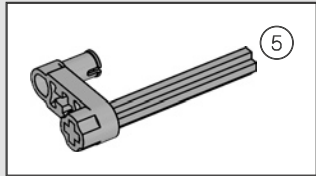

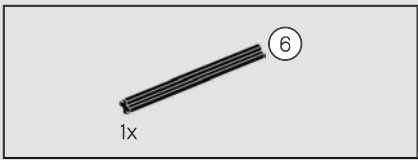

326

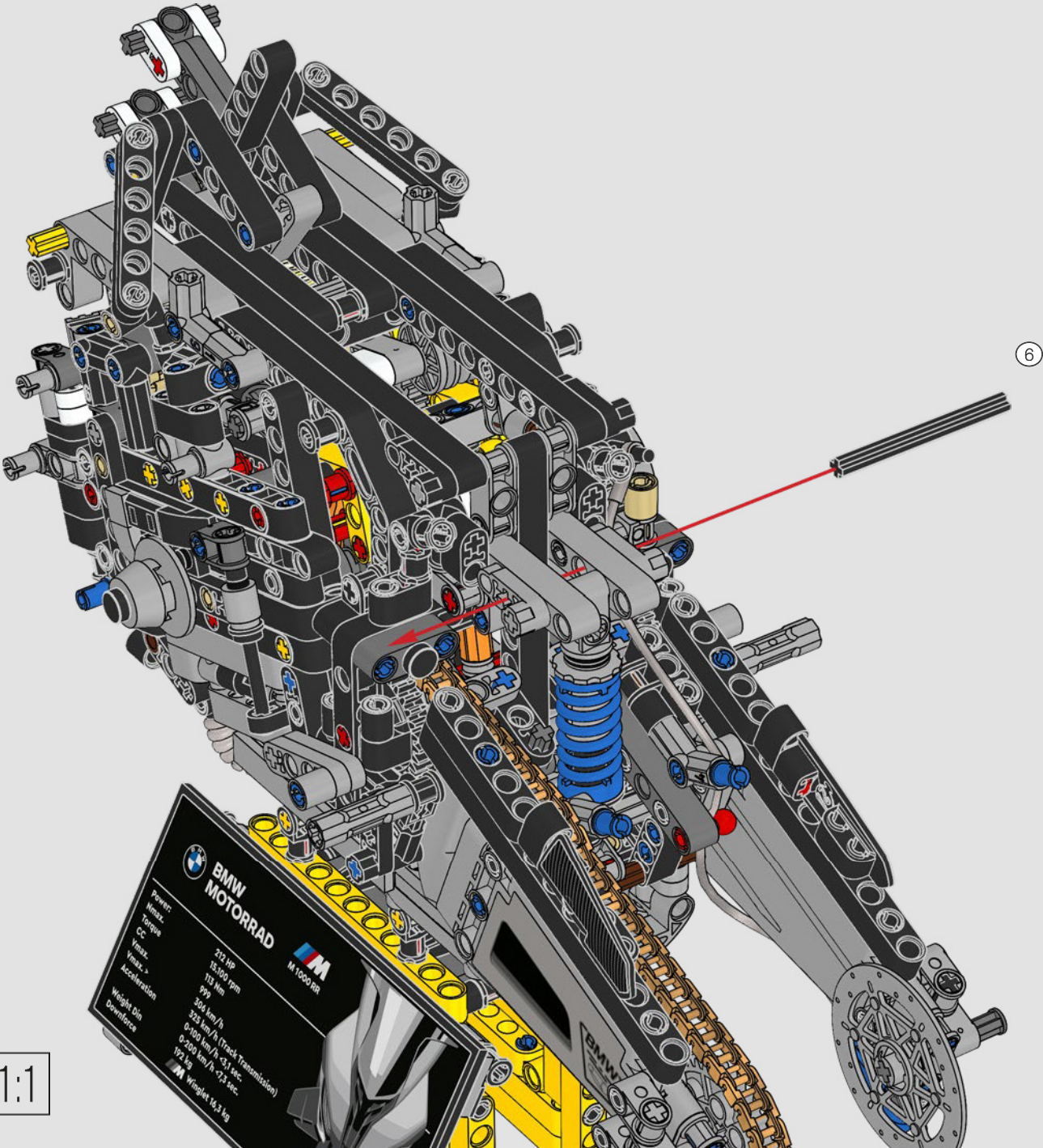

BMW MOTORRAD **M 1000 RR**

Power	217 HP
Max. torque	15,100 Nm
CC	113 Nm
Vmax	99
Vmax >	304 km/h
Acceleration	325 km/h (Track transmission)
Weight (Dry)	0-200 km/h < 3.1 sec.
Downforce	0-200 km/h < 3.1 sec.
	172 kg
	Weight 14.3 kg



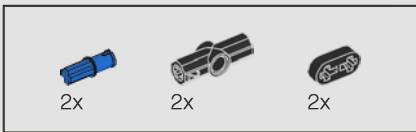

327

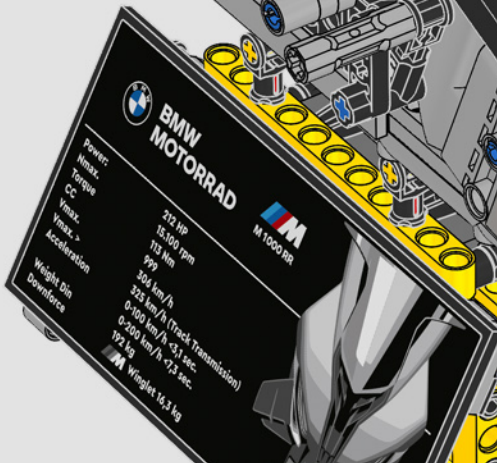
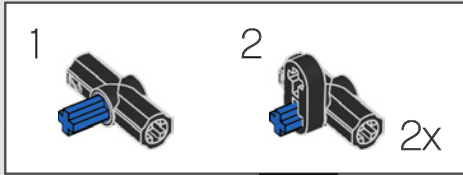
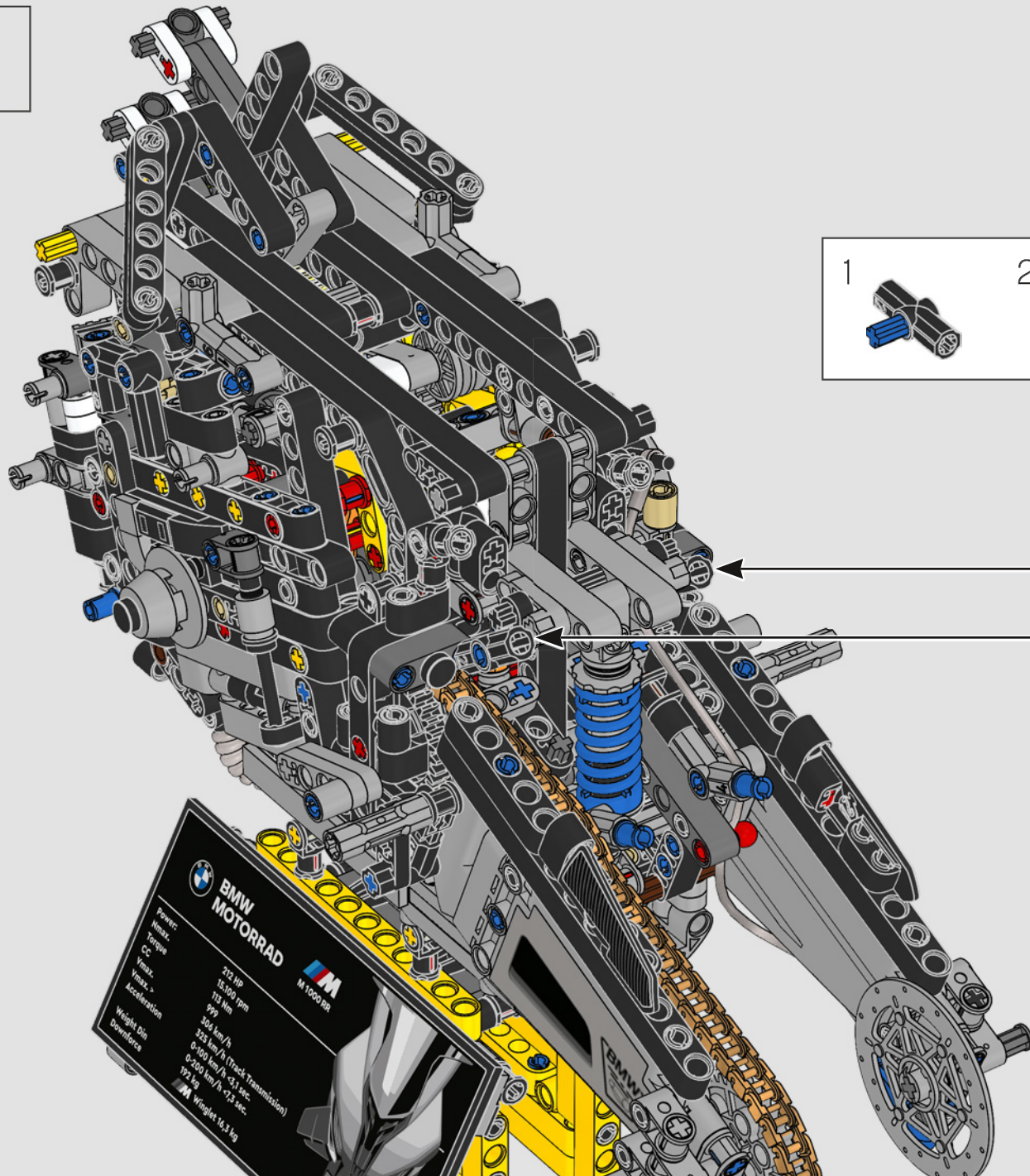

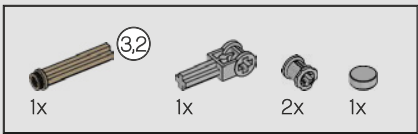

328

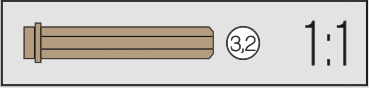
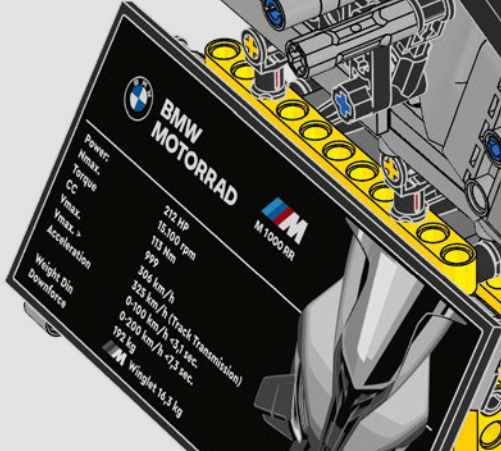
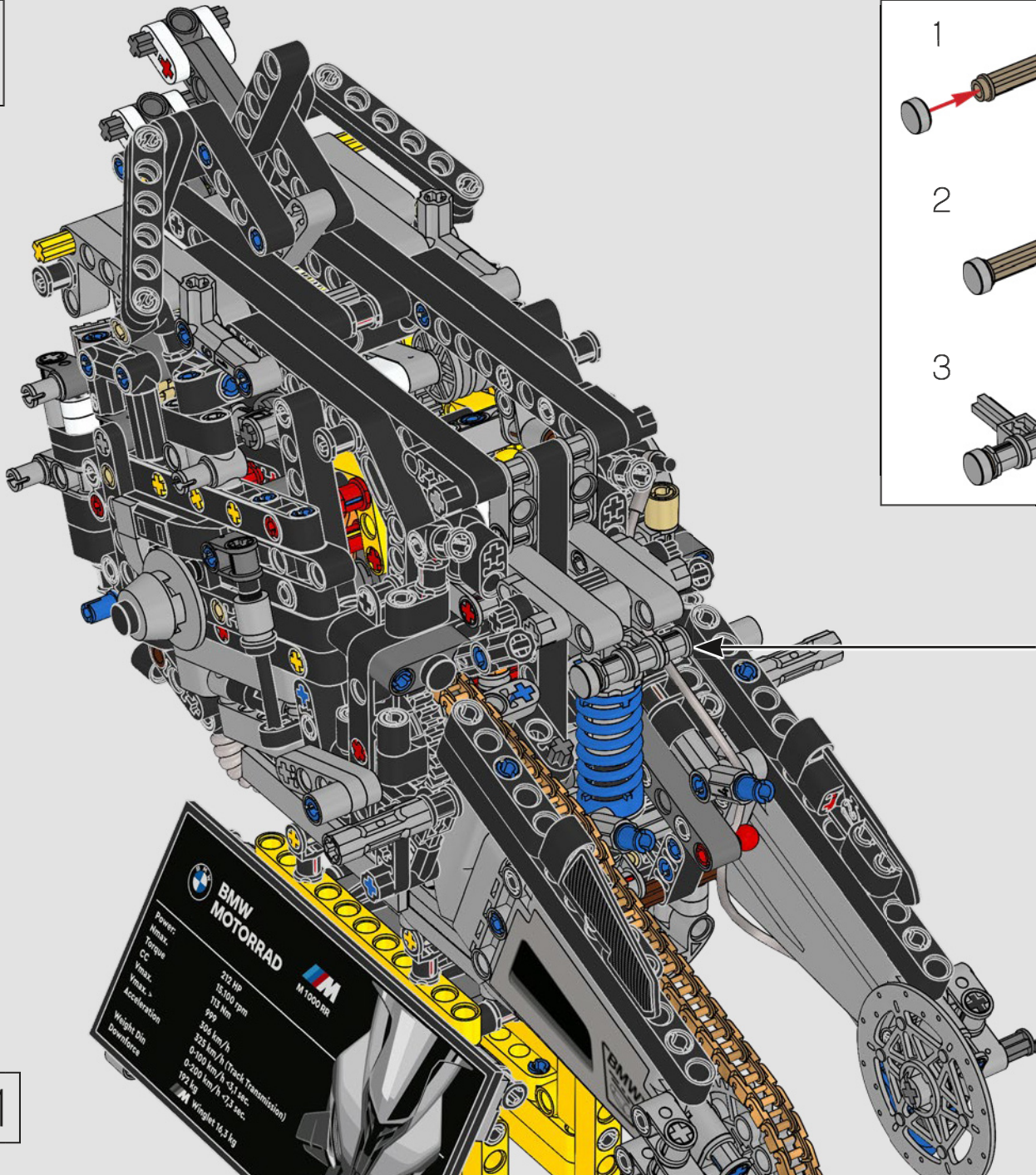
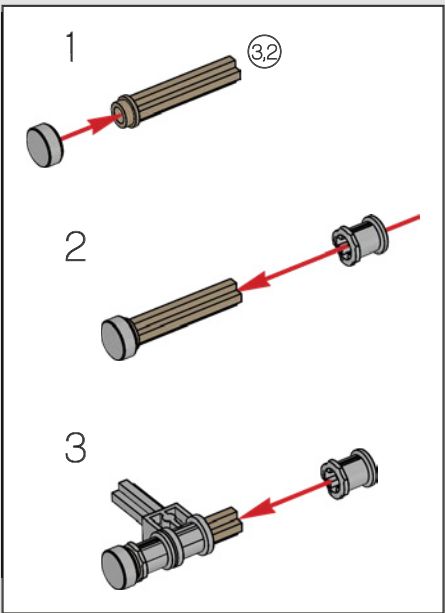

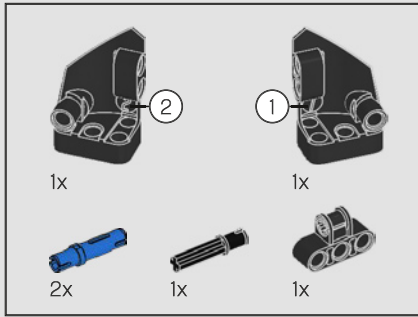

329

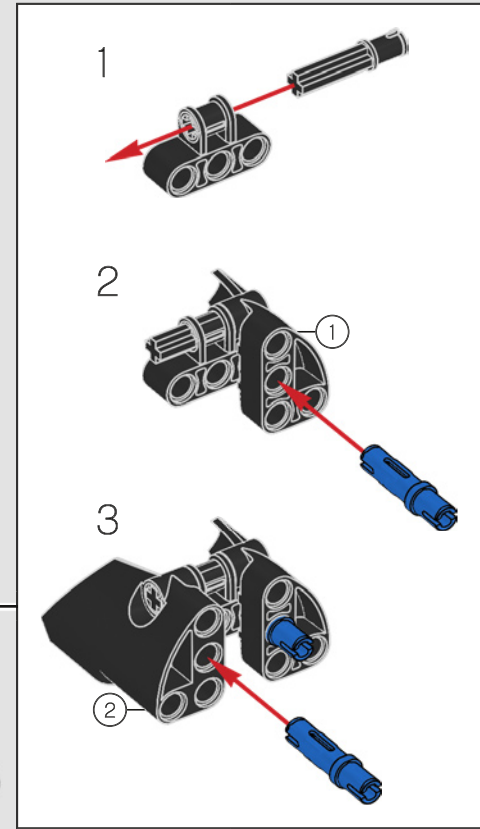
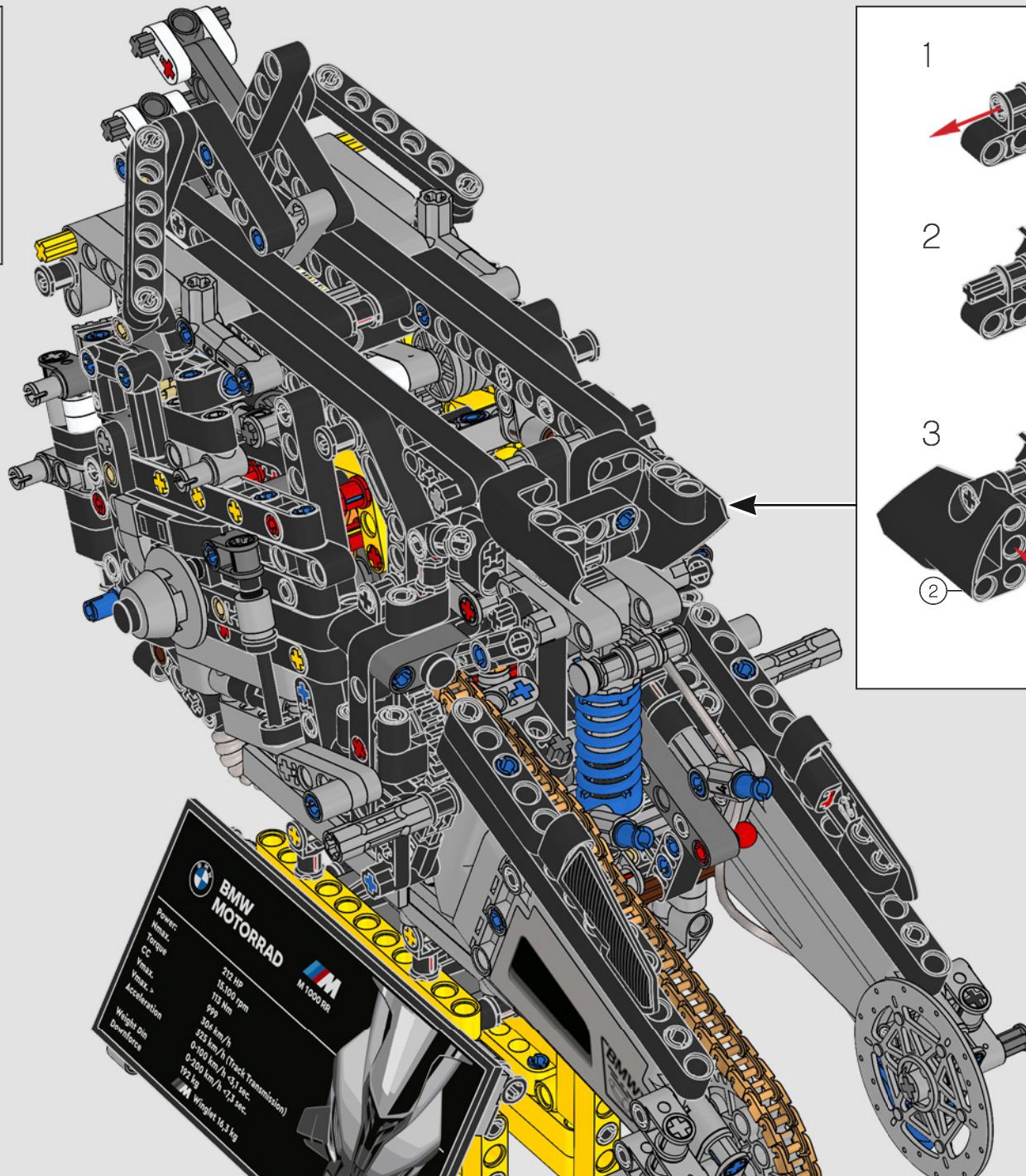

BMW MOTORRAD		M 1000 RR
Power	213 HP	
Max. Torque	15.500 rpm	
CC	1733 cm ³	
0-100 km/h	3.1 sec.	
0-200 km/h	11.3 sec.	
Weight (incl. downforce)	192 kg	
Weight (dry)	163 kg	

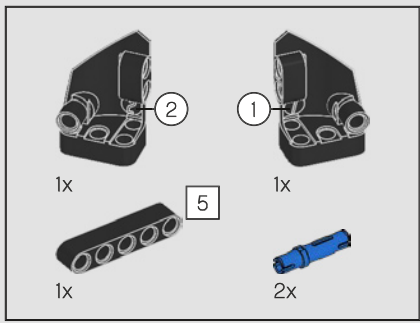

330

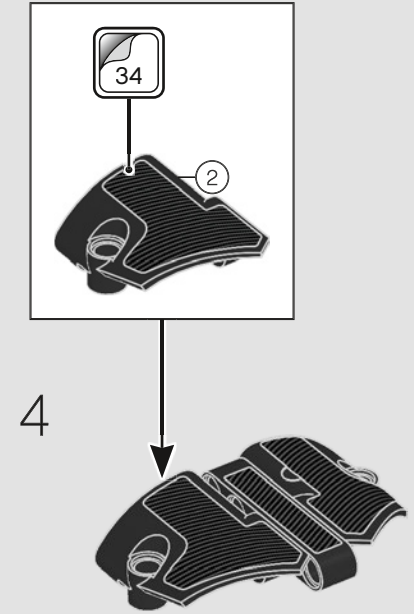
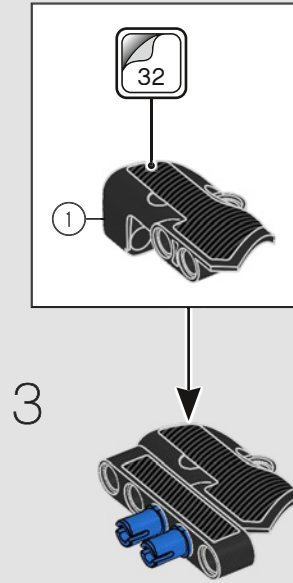
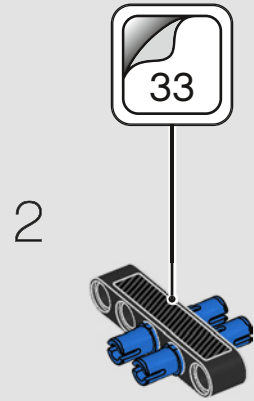
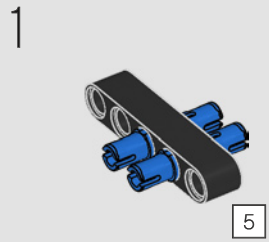

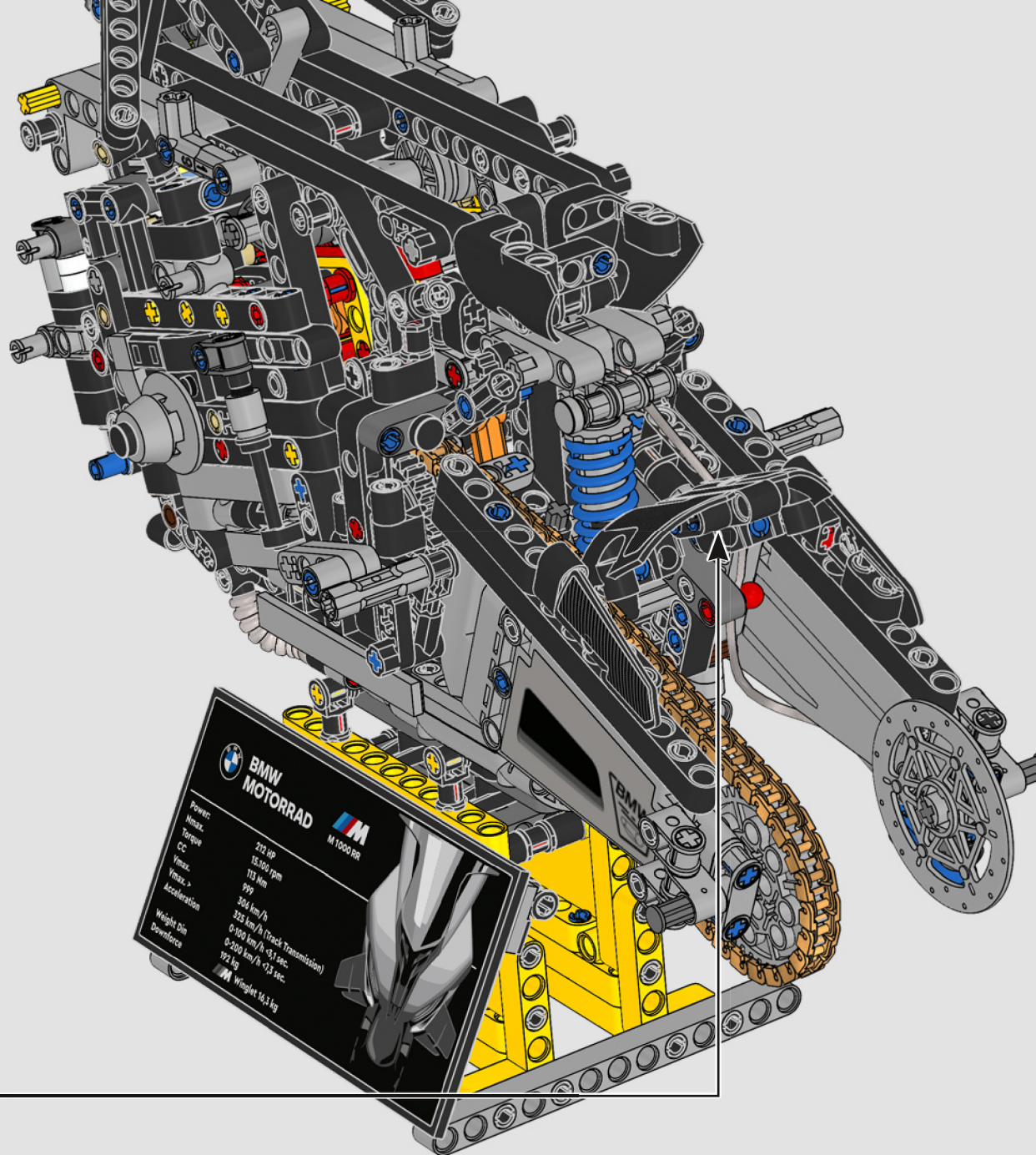

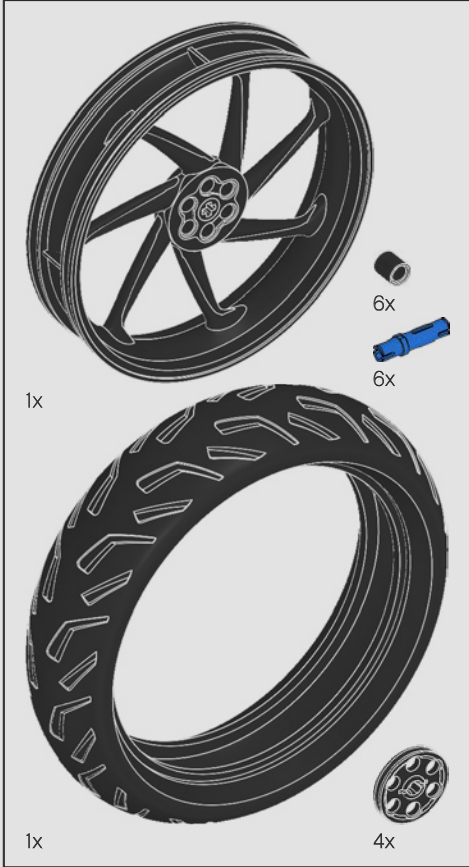
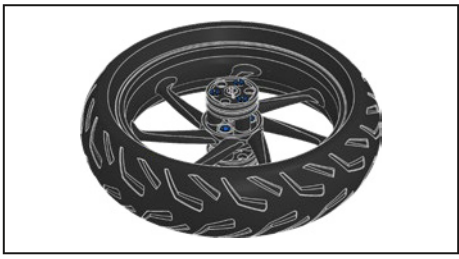

1

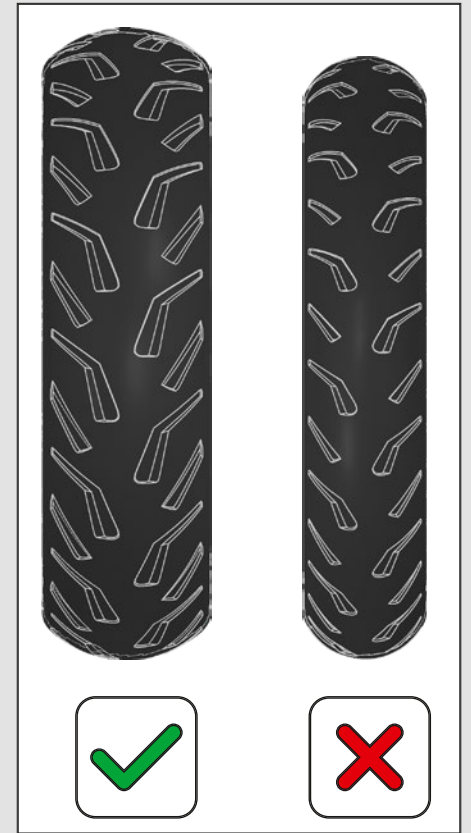

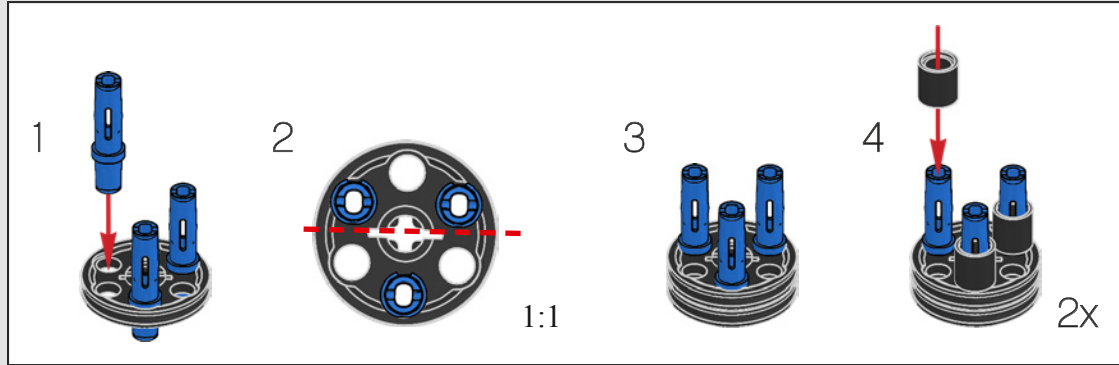

331

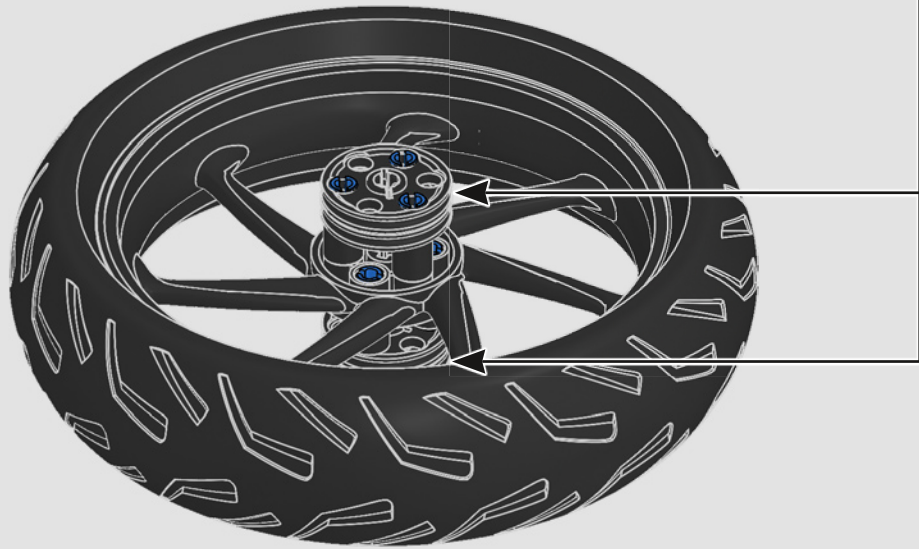

2

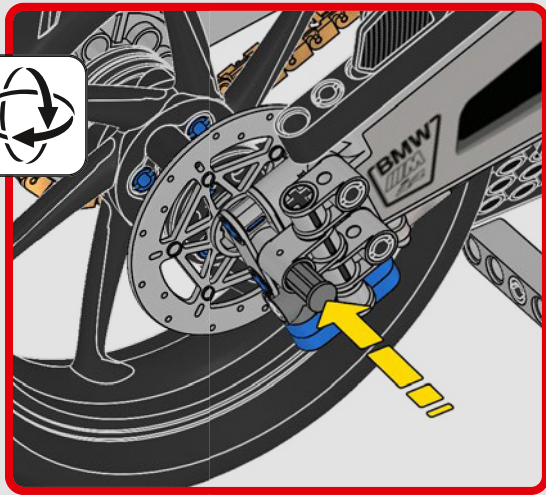
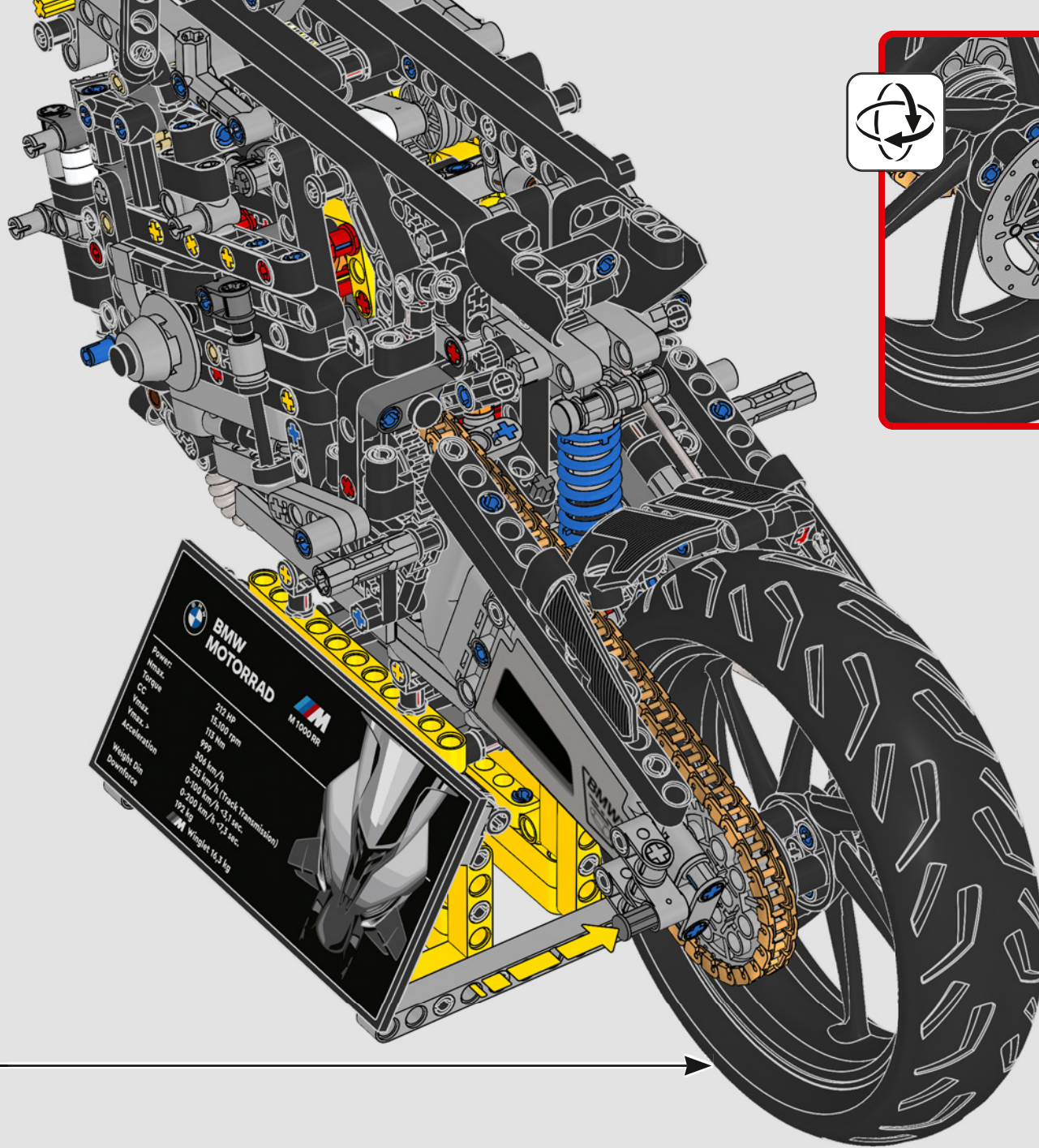



BMW MOTORRAD  **M 1000 RR**

Power:	212 HP
Top speed:	15,100 rpm
CC	113 cm
Vmax. >	999
Acceleration	306 km/h
Weight Dry	325 km/h (Track Transmission)
Downforce	0-200 km/h < 3 sec.
	0-200 km/h < 2.3 sec.
	172 km
	Weight 14.3 kg

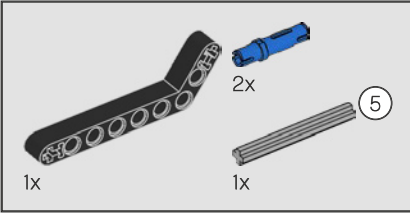
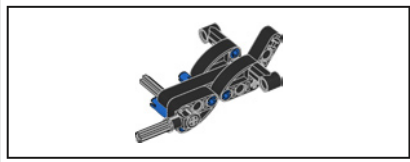

332

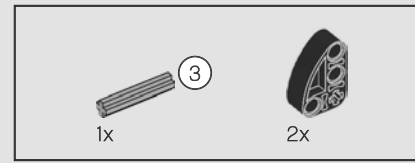
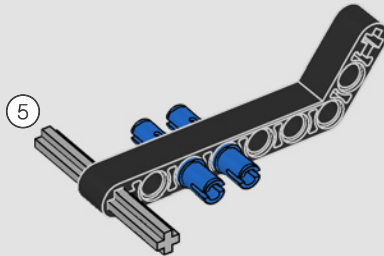

333

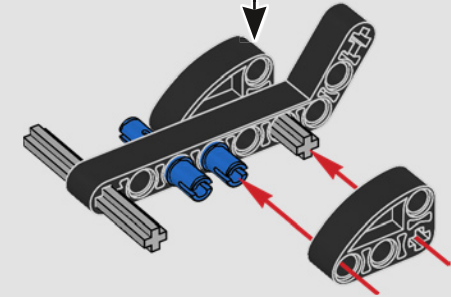
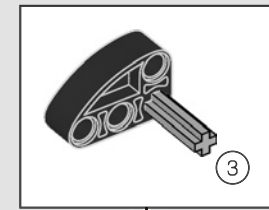

334

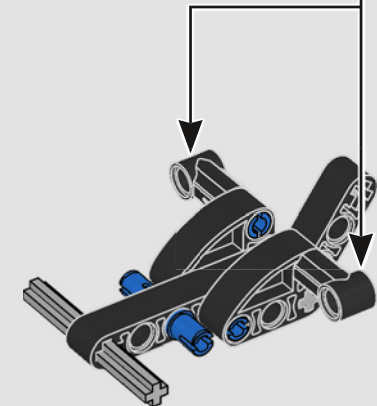

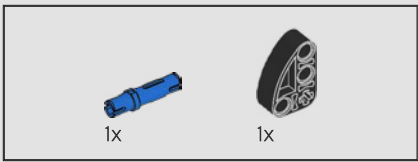

335

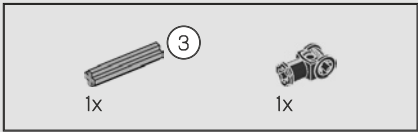
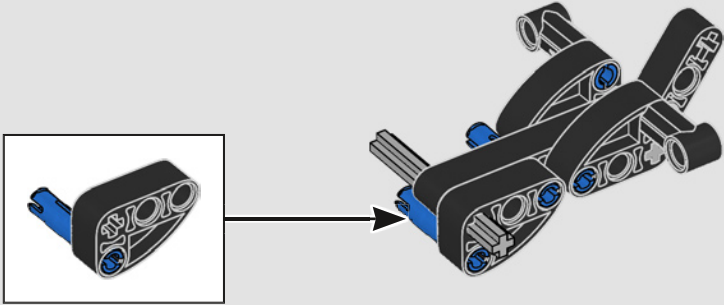

336

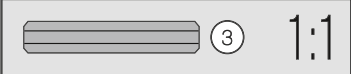
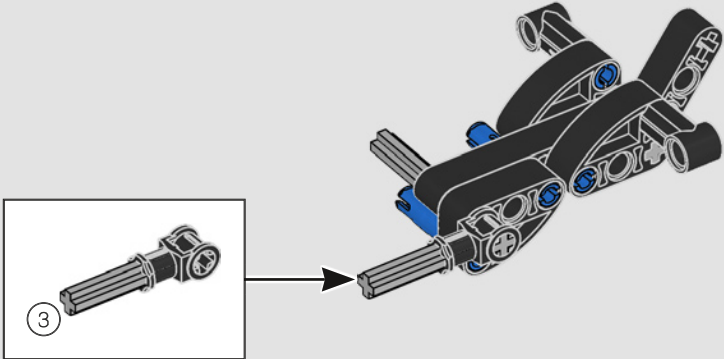

337

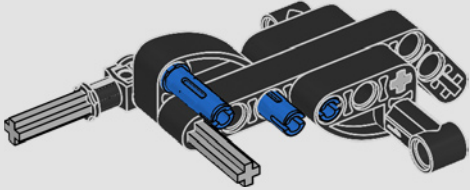

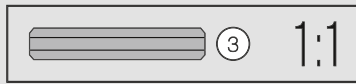
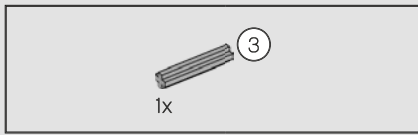

338

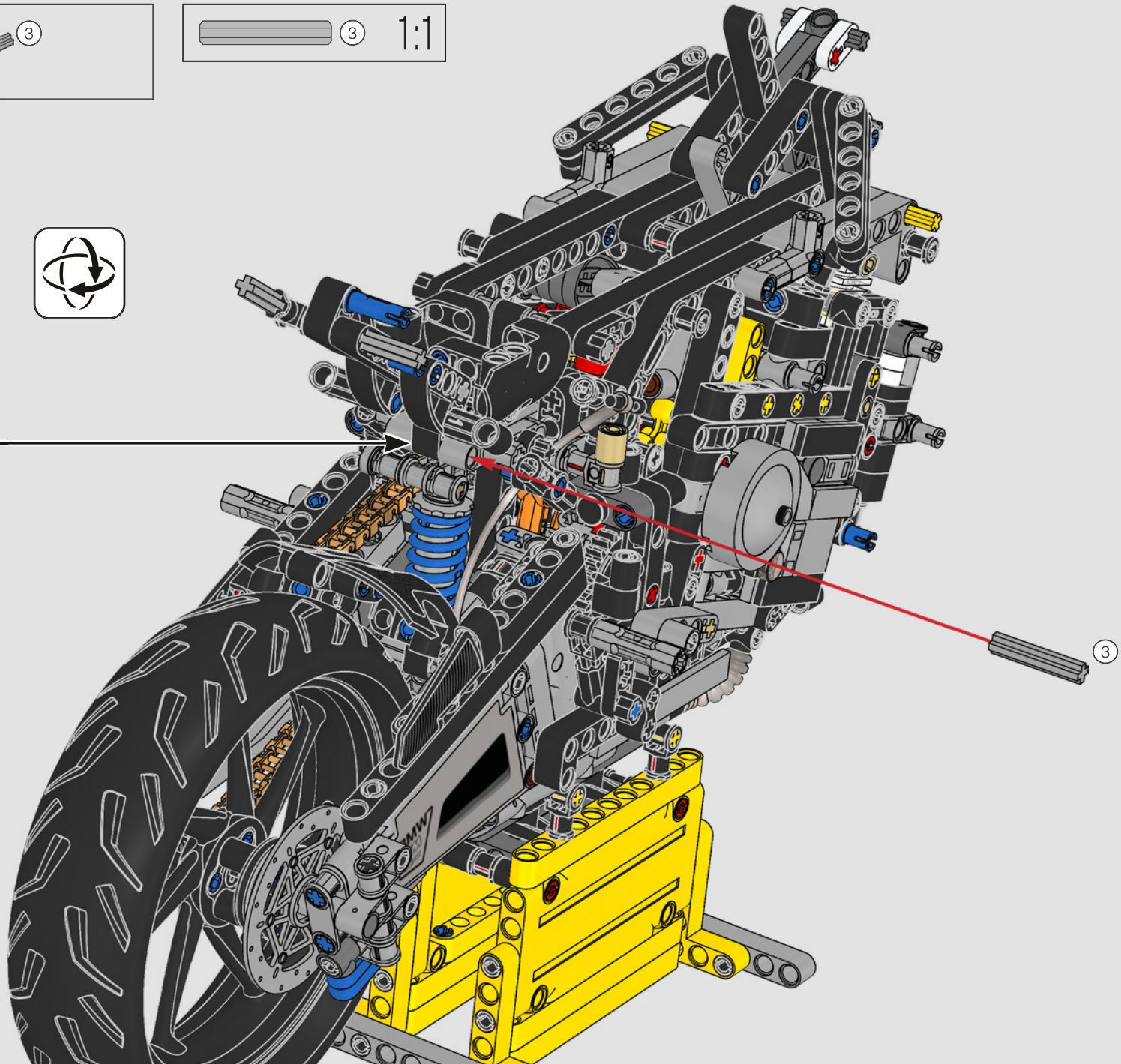

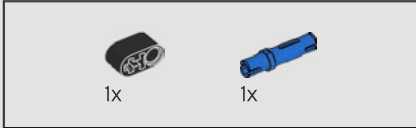
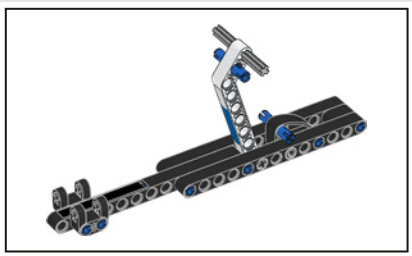

339

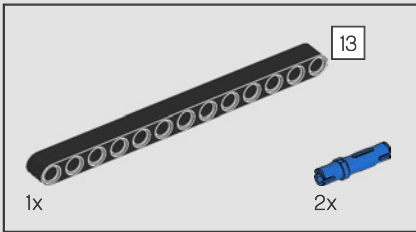

340

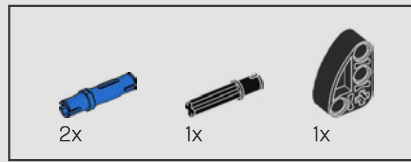
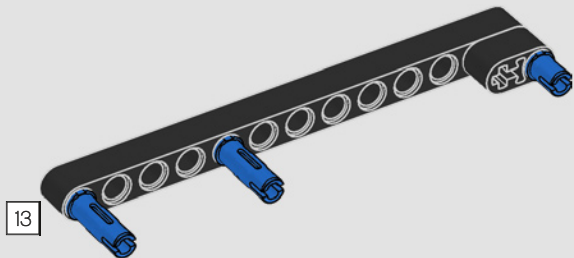

341

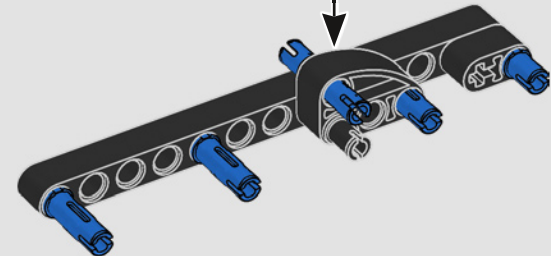
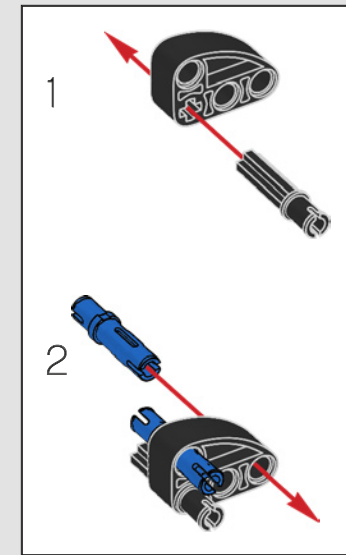

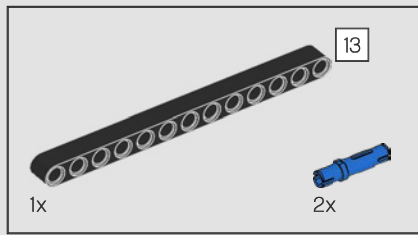

342

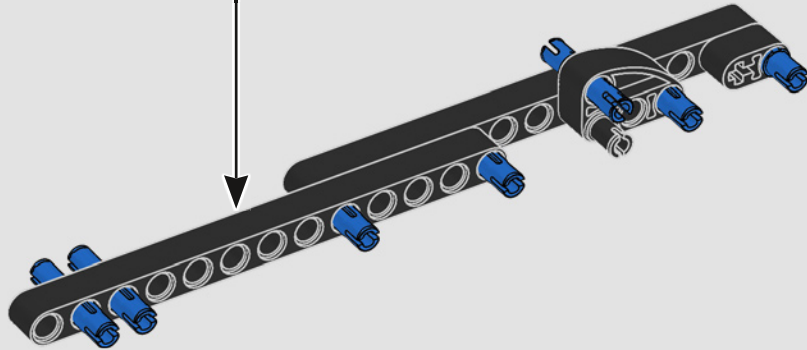
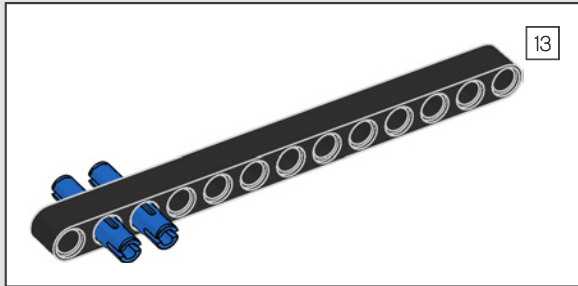

343

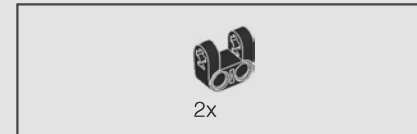
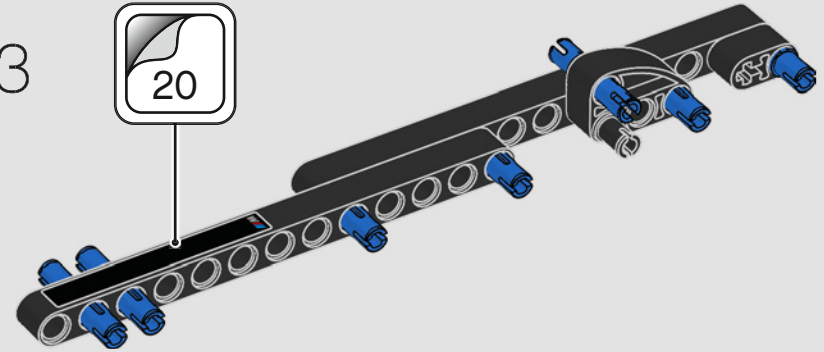

344

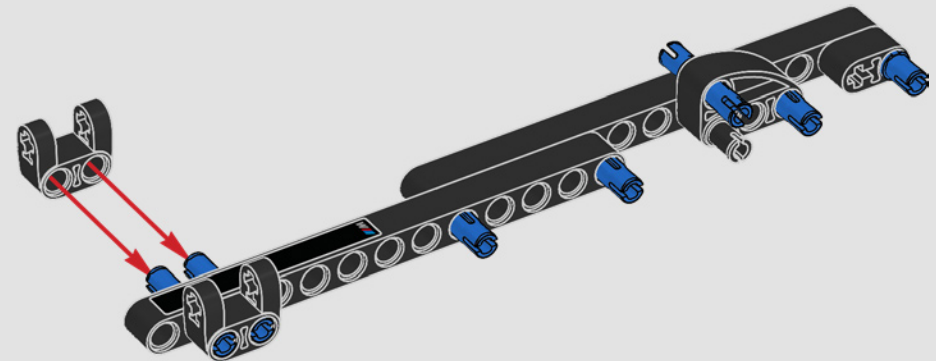

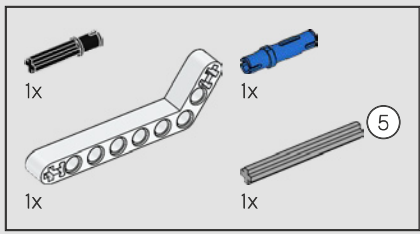

345

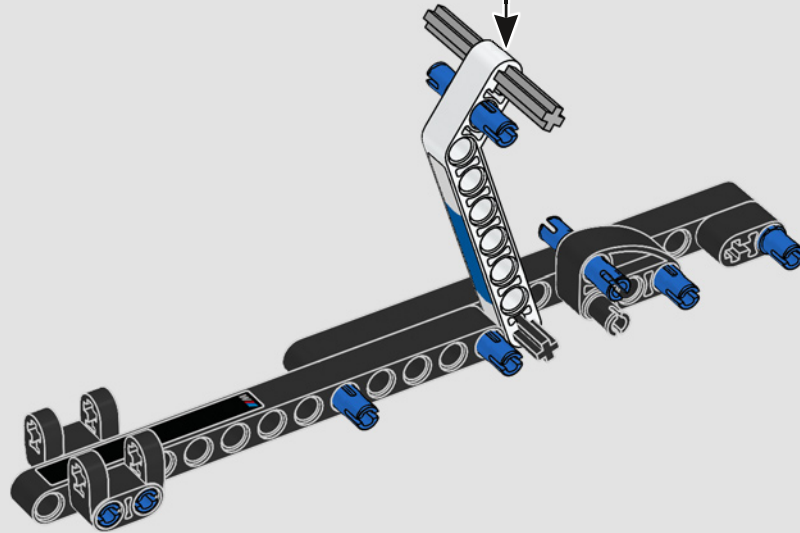
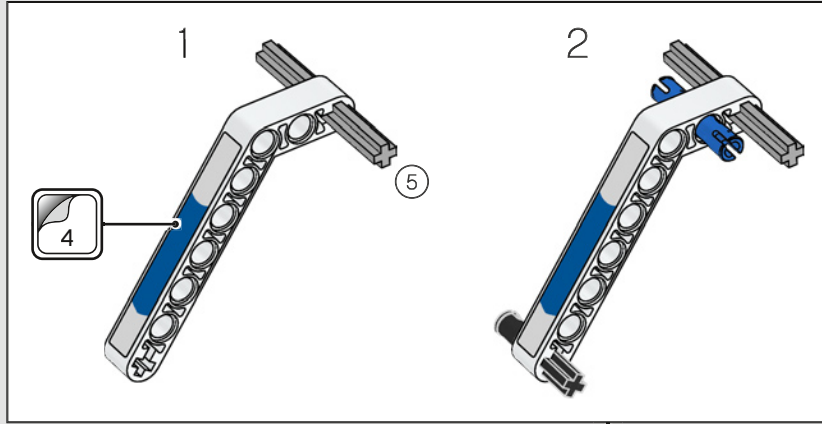
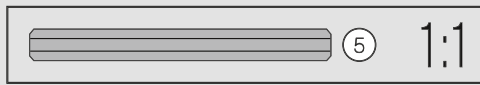

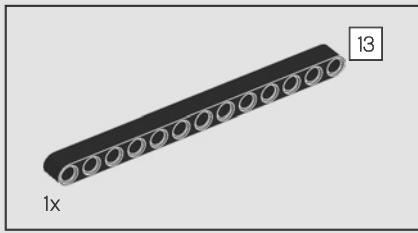

346

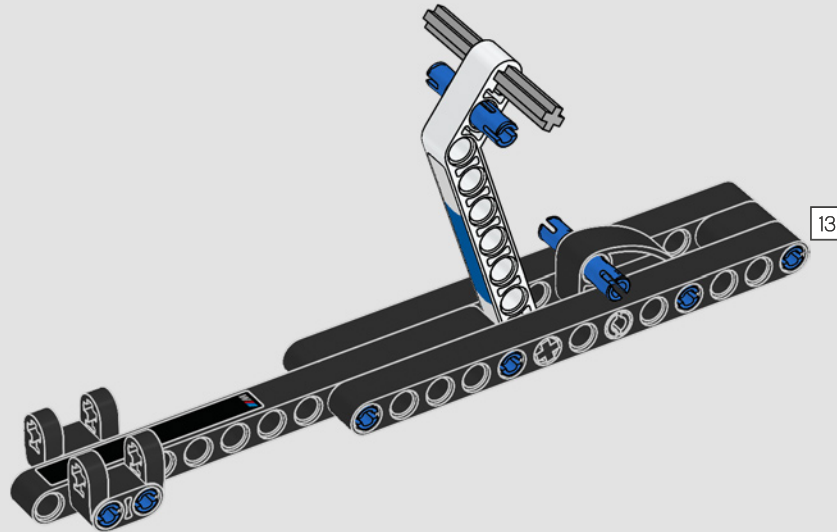

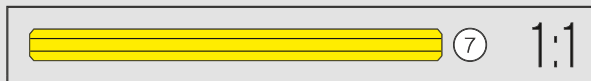
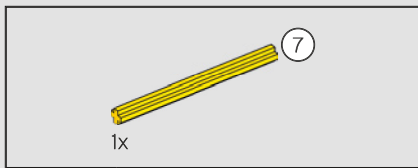

347

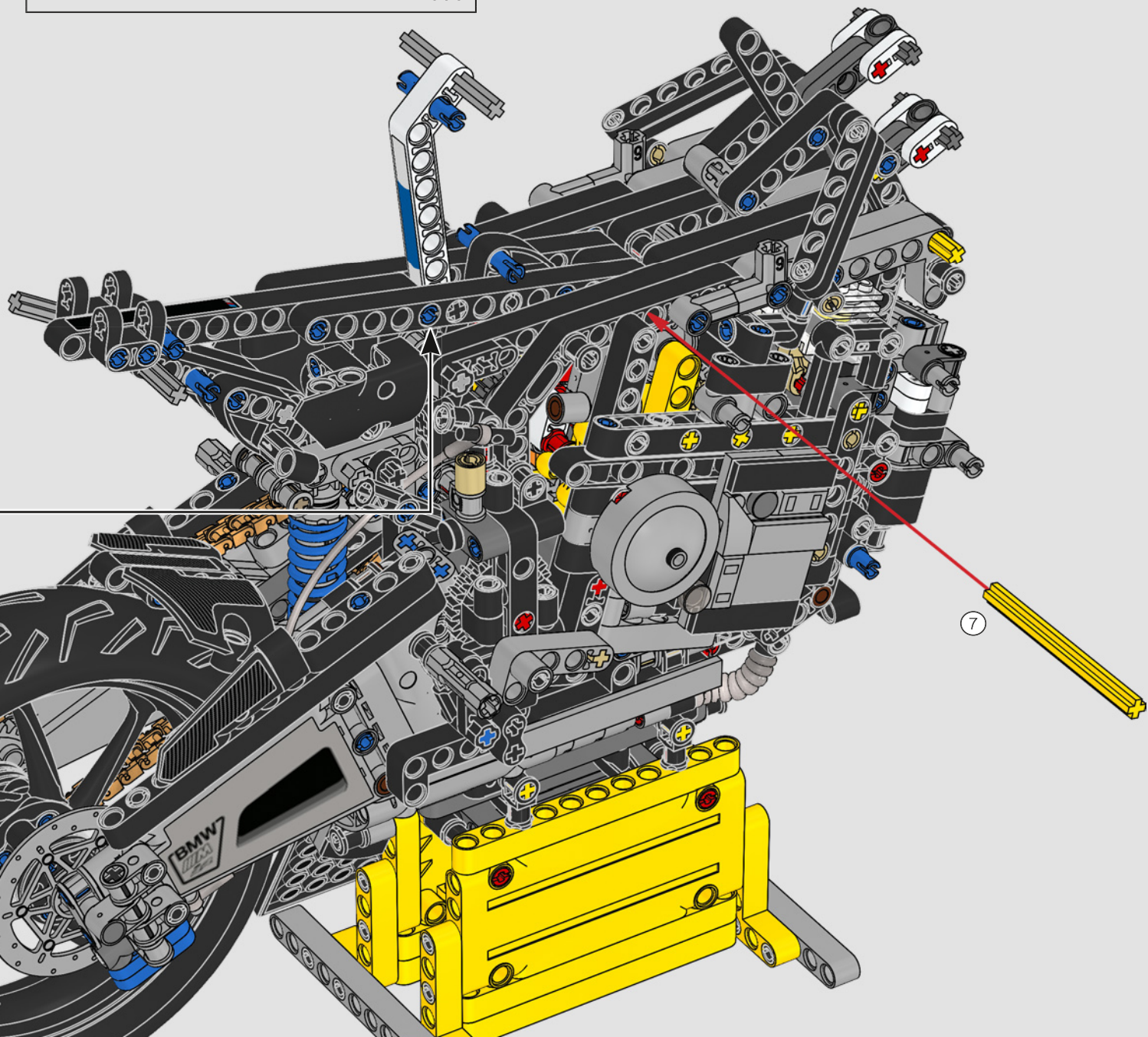
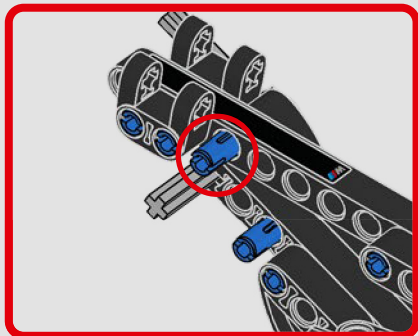

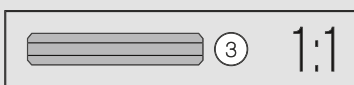

348

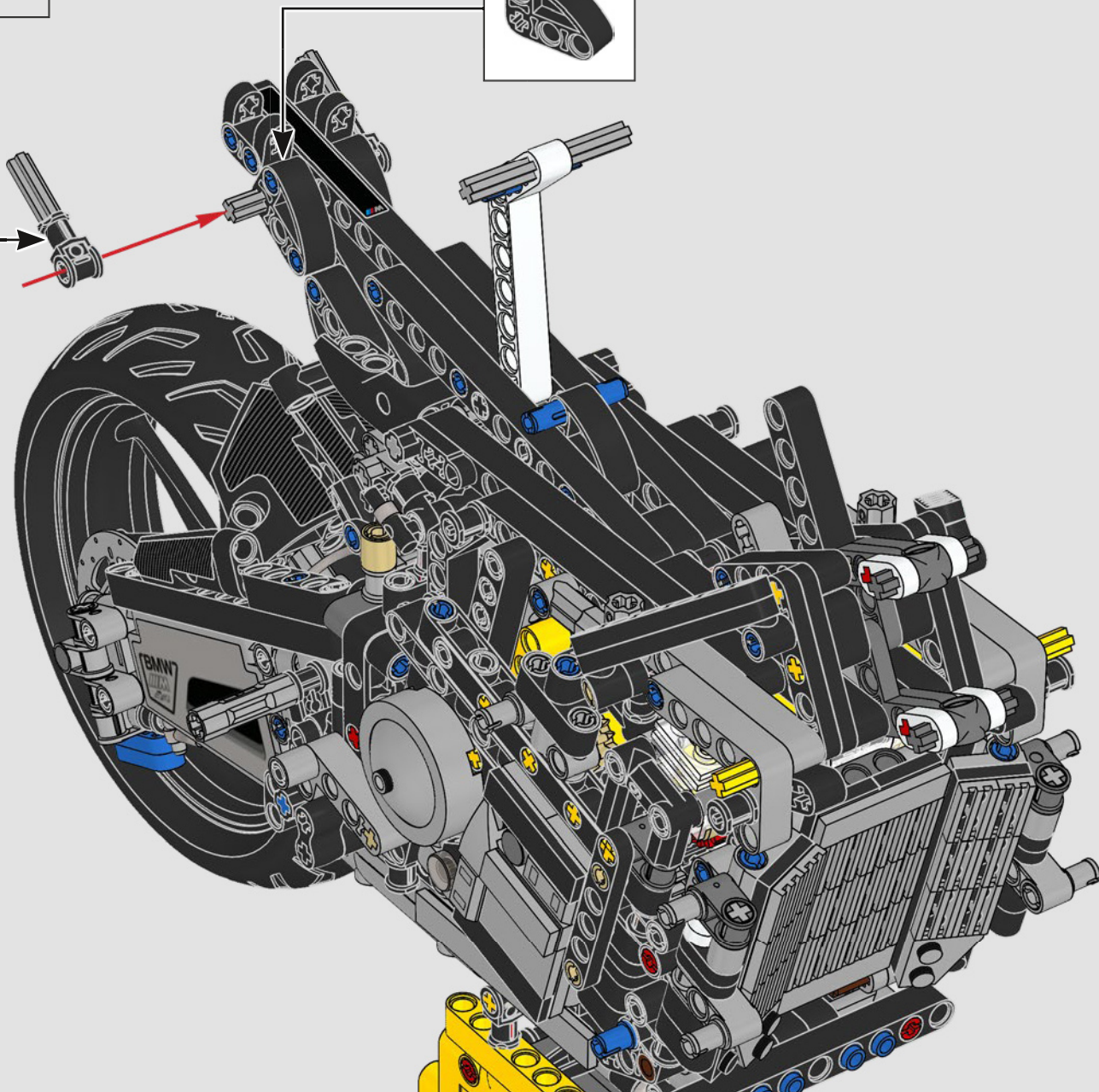
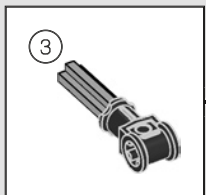

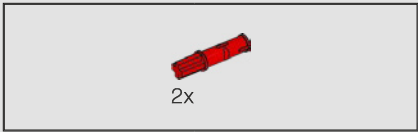

349

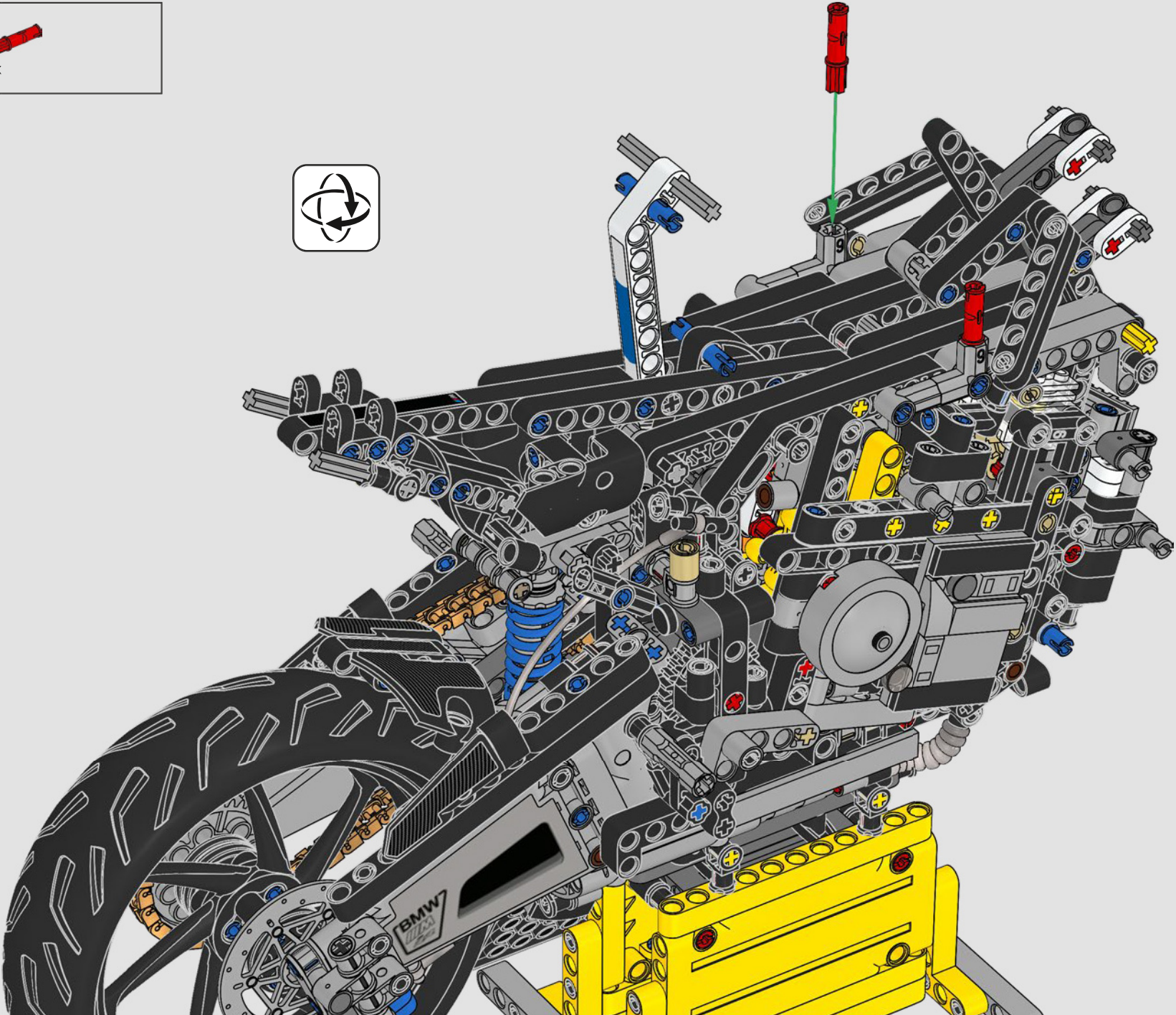

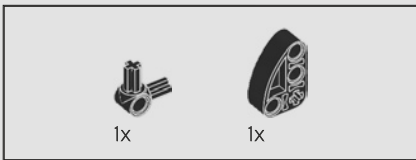

350

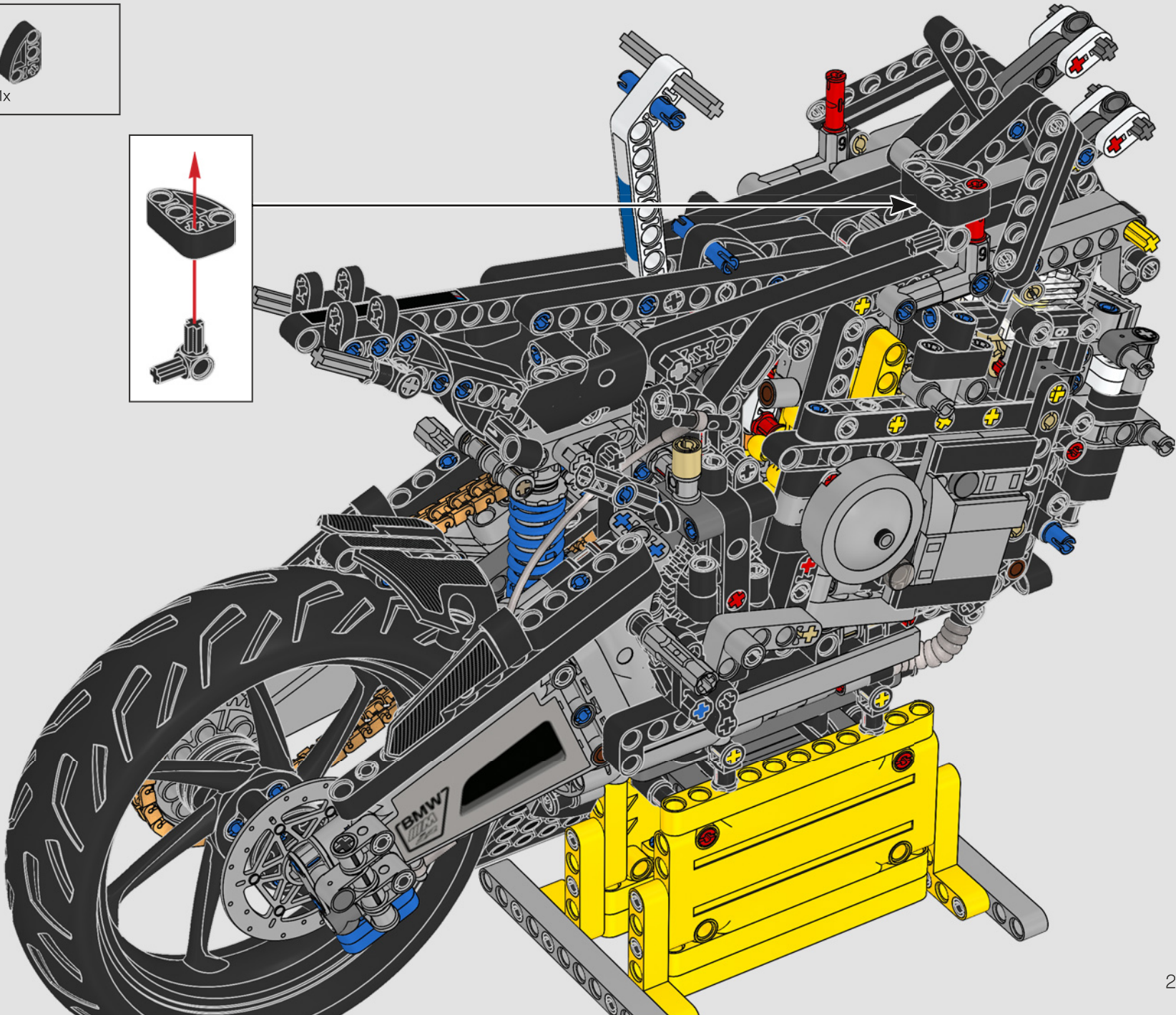
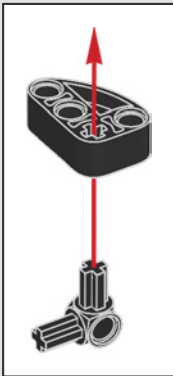

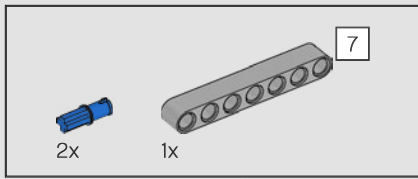

351

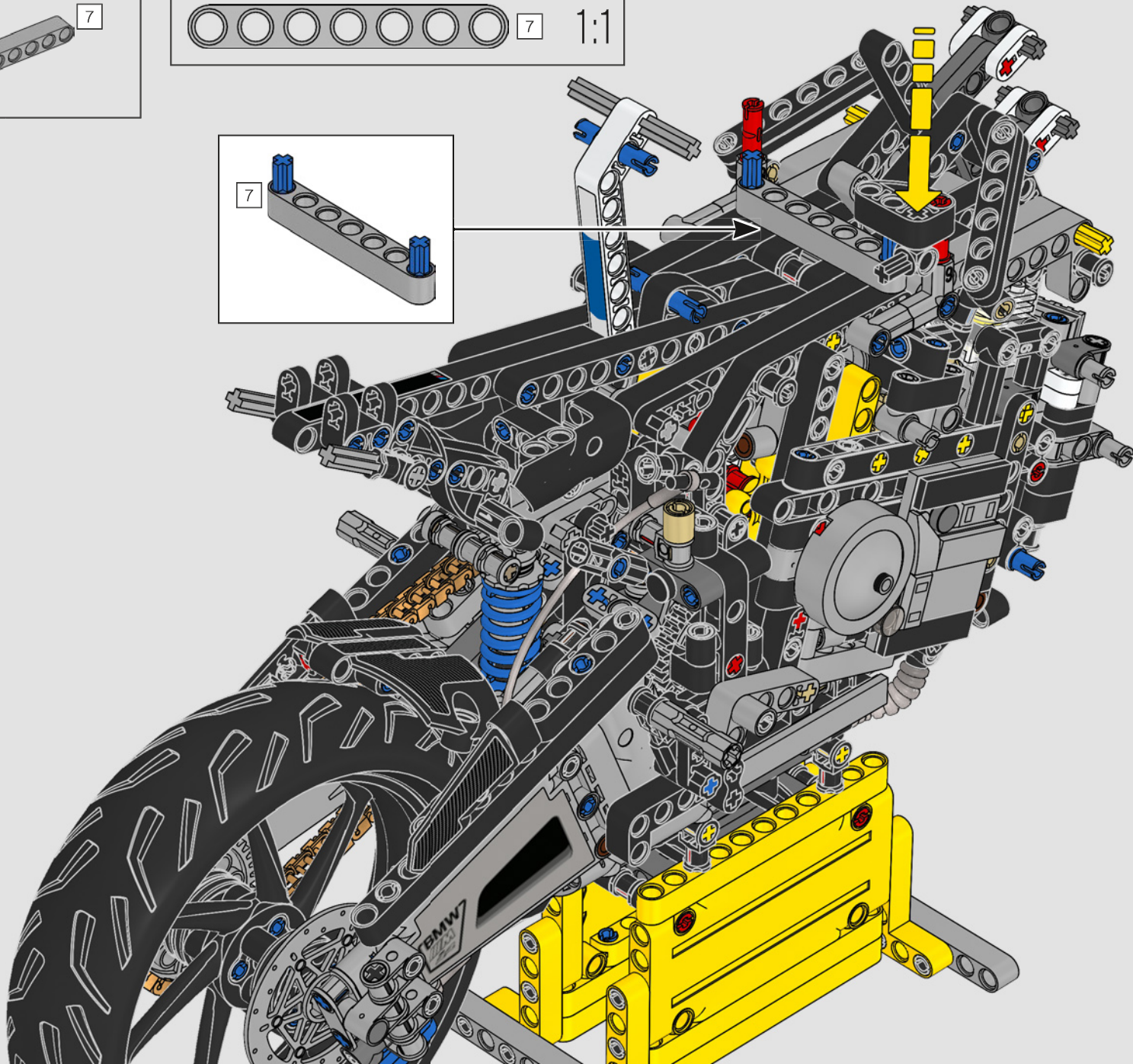
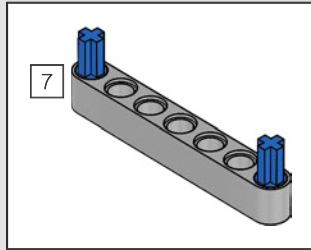

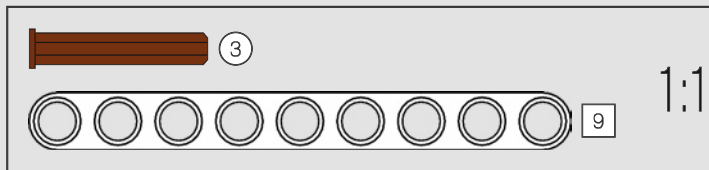
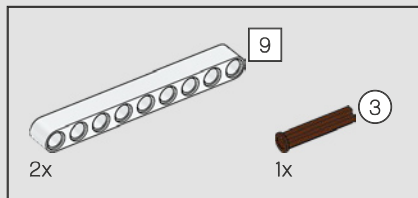

352

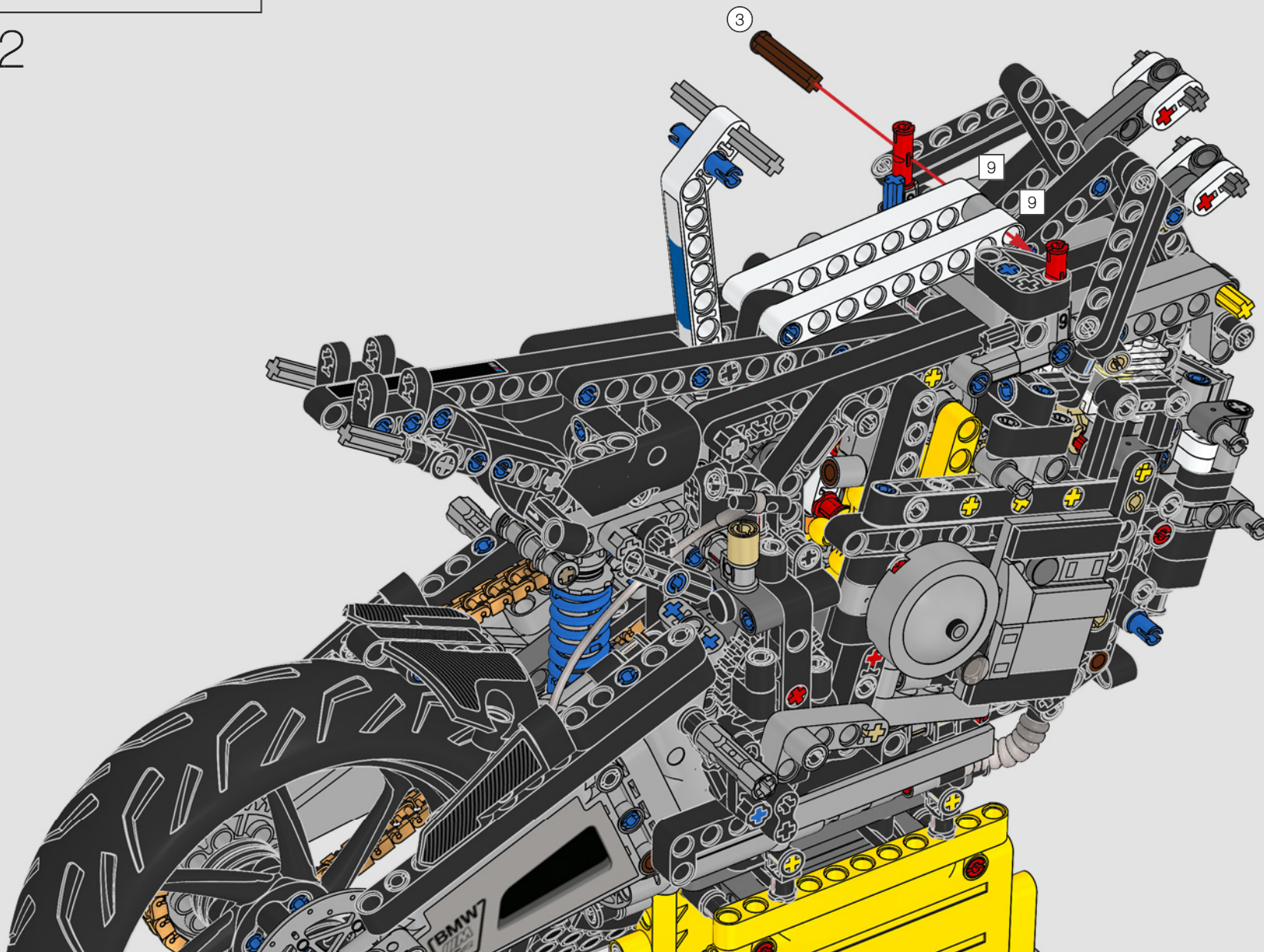

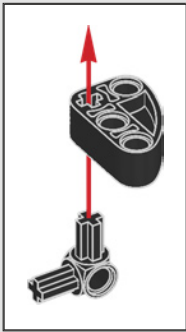
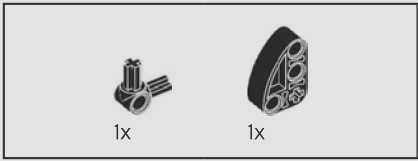

353

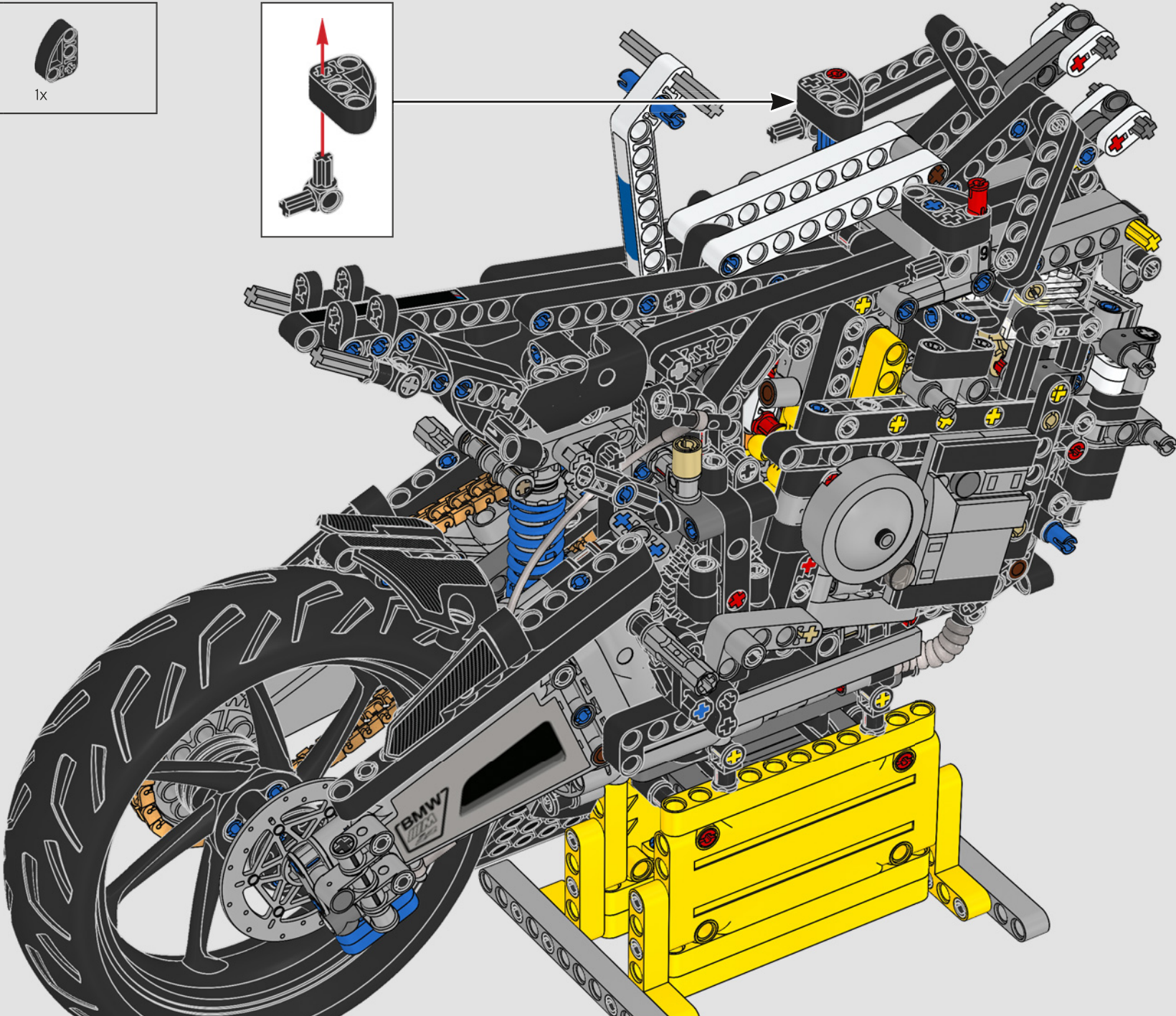

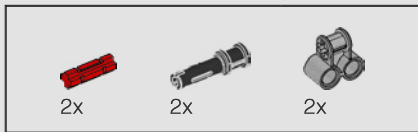

354

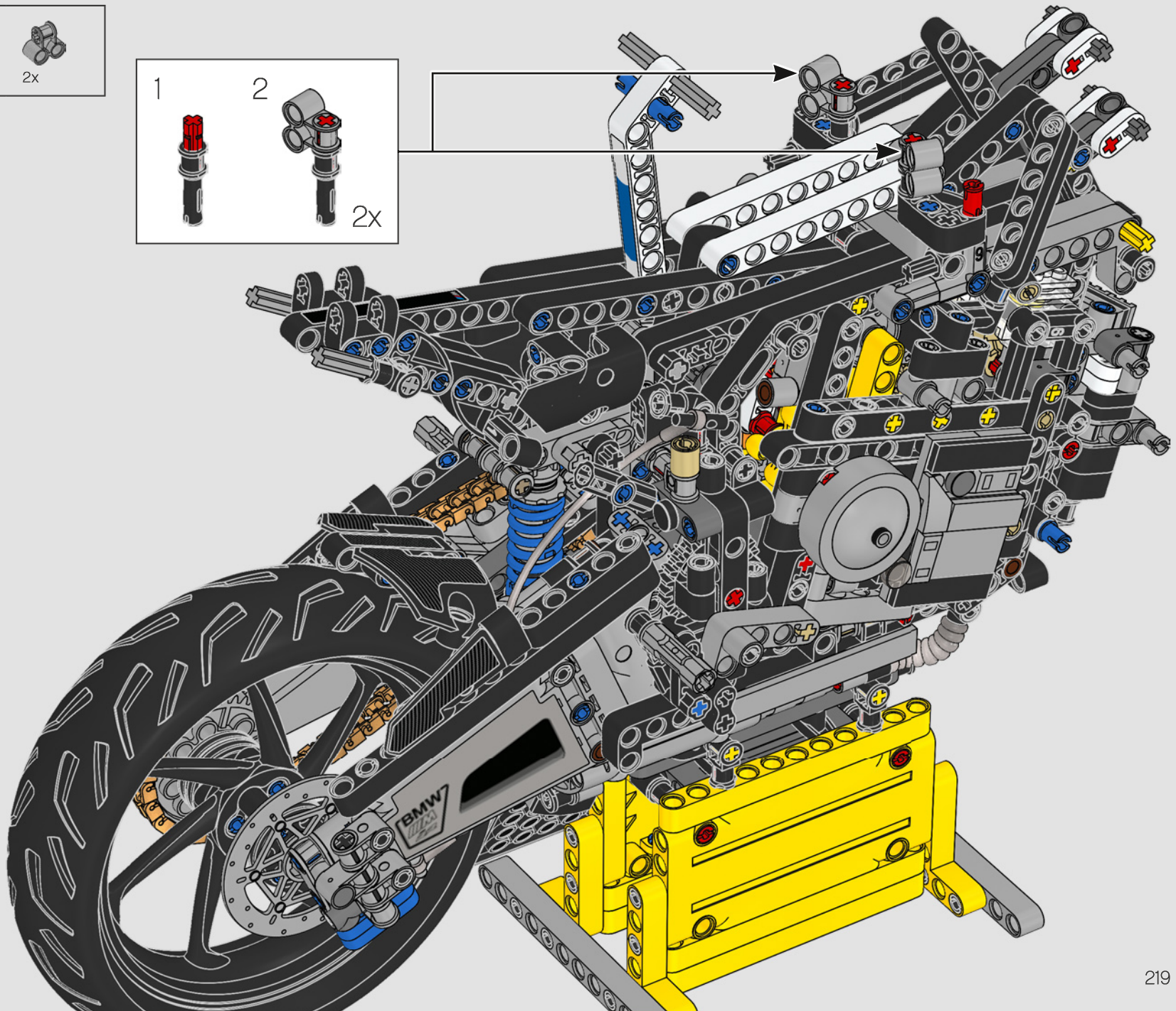
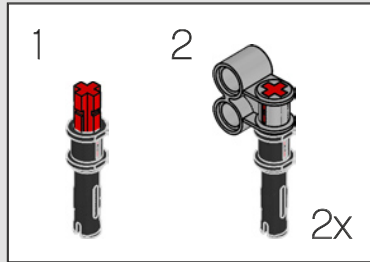

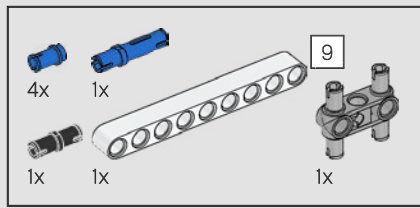

355

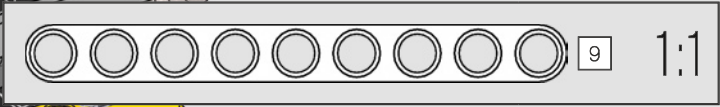
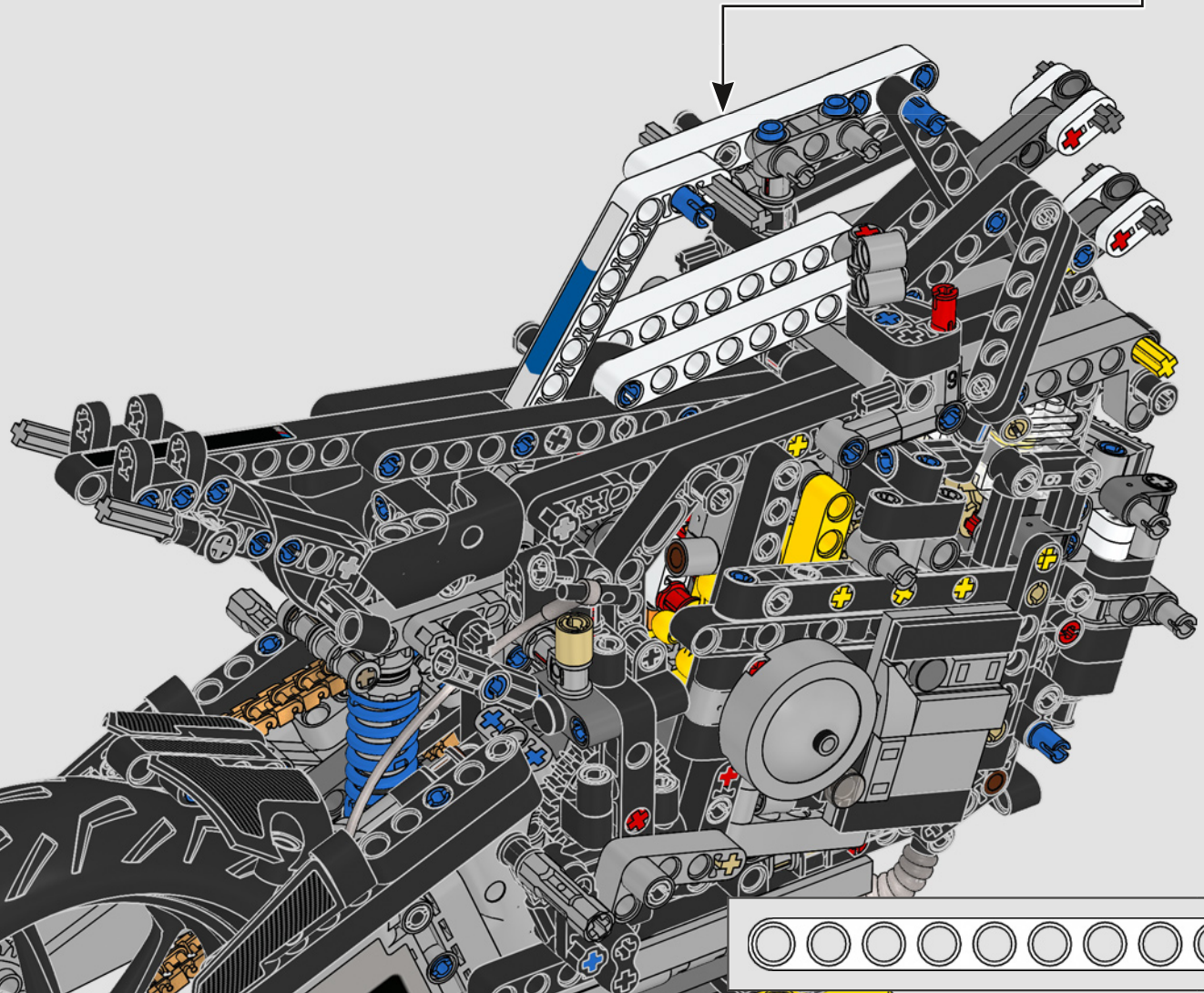
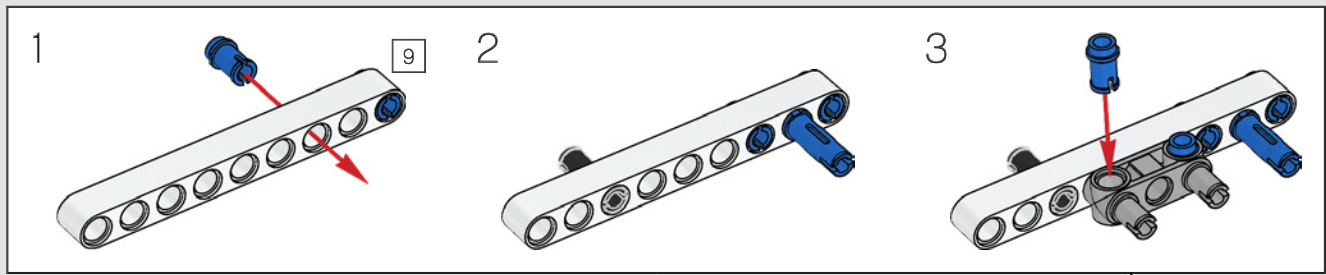

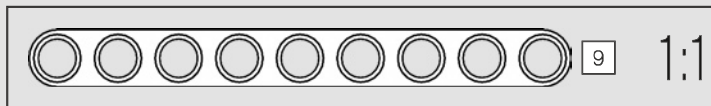
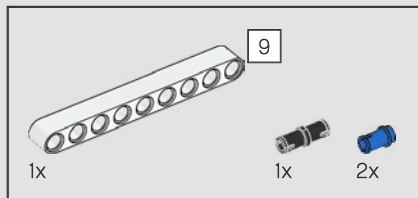

356

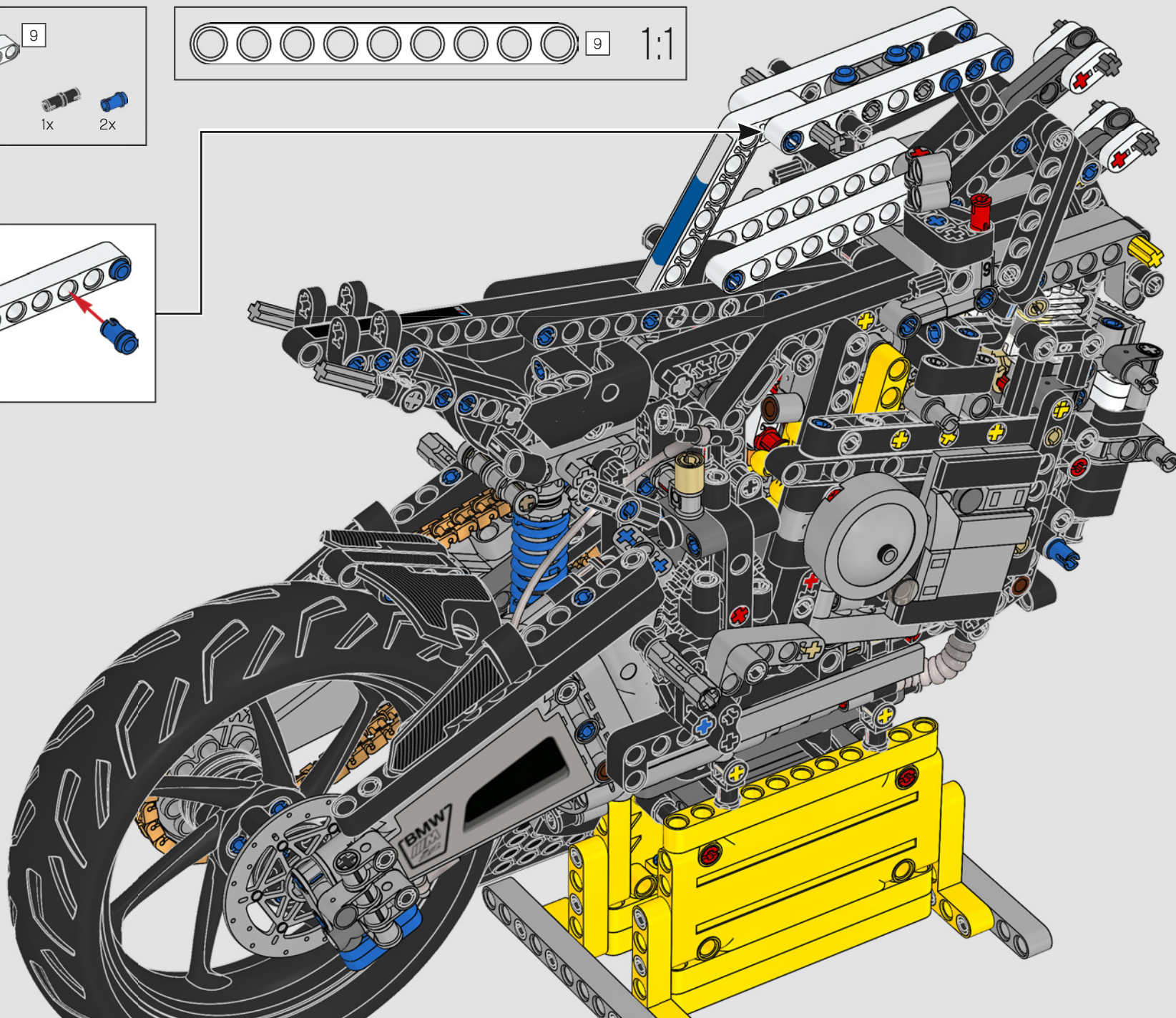
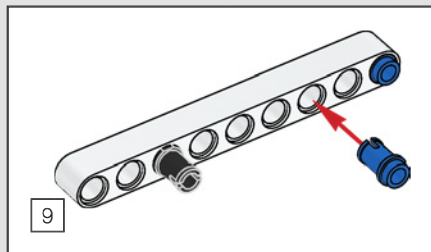

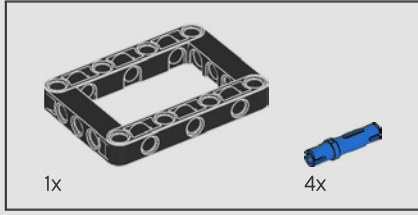
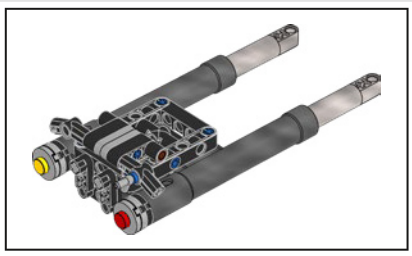

357

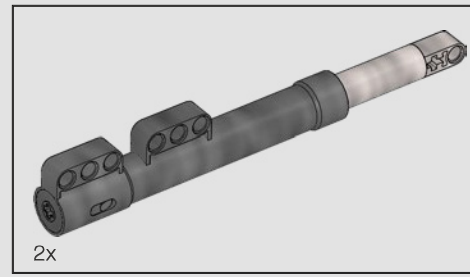
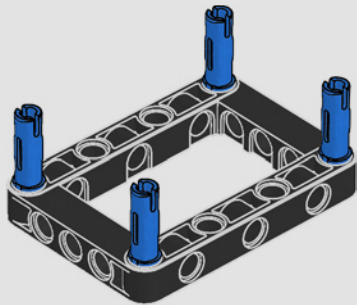

358

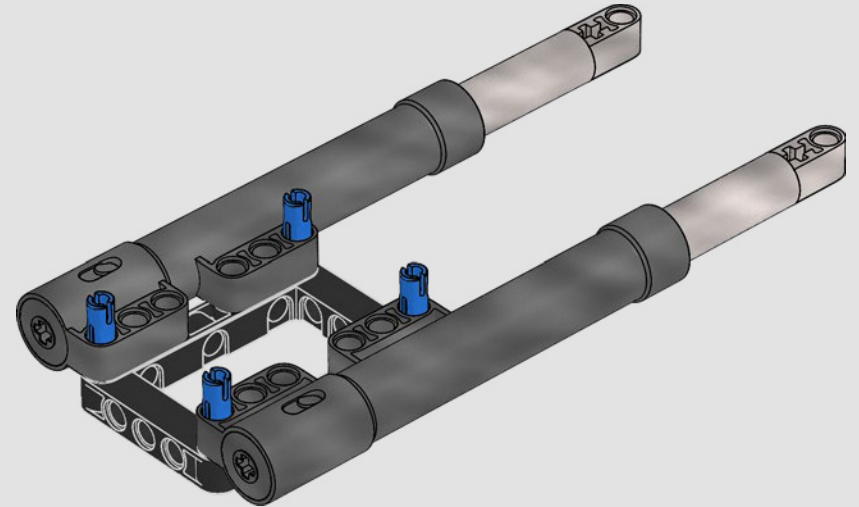

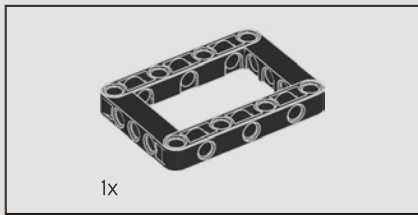

1x

359

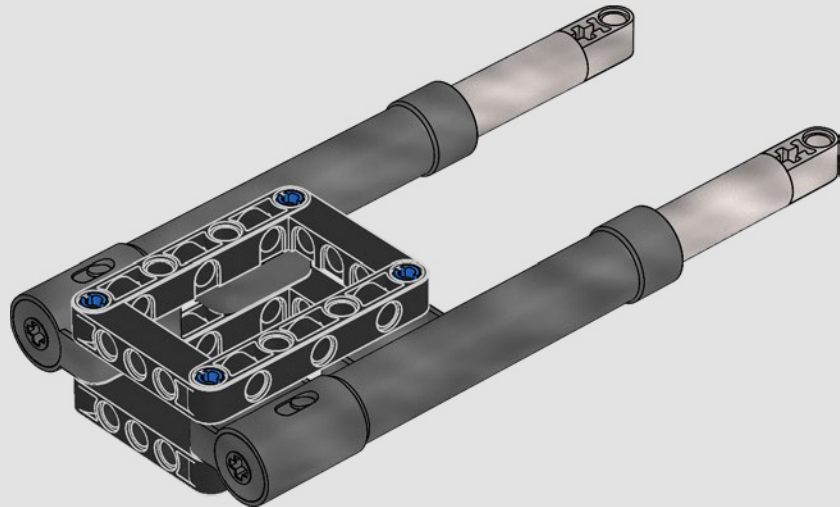

360

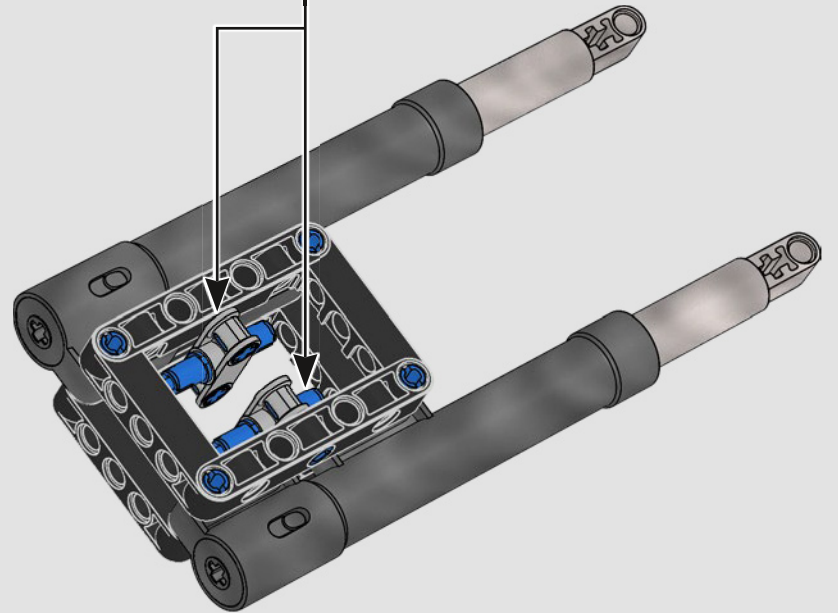
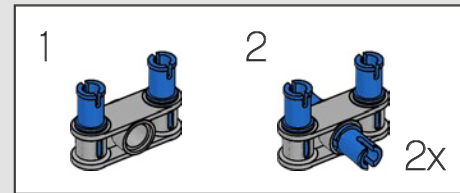
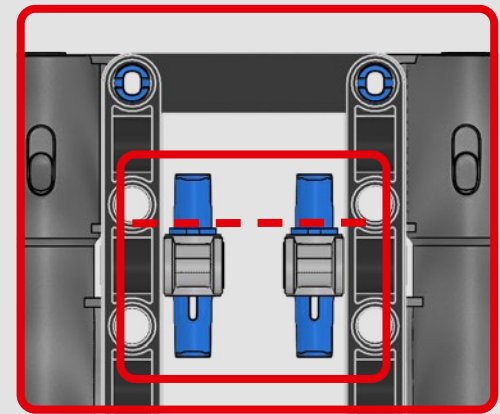

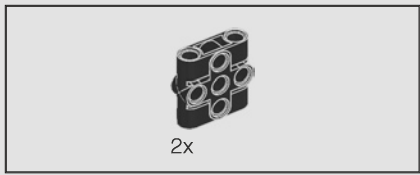

361

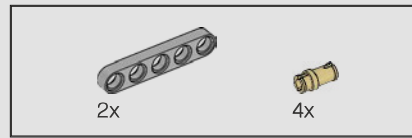
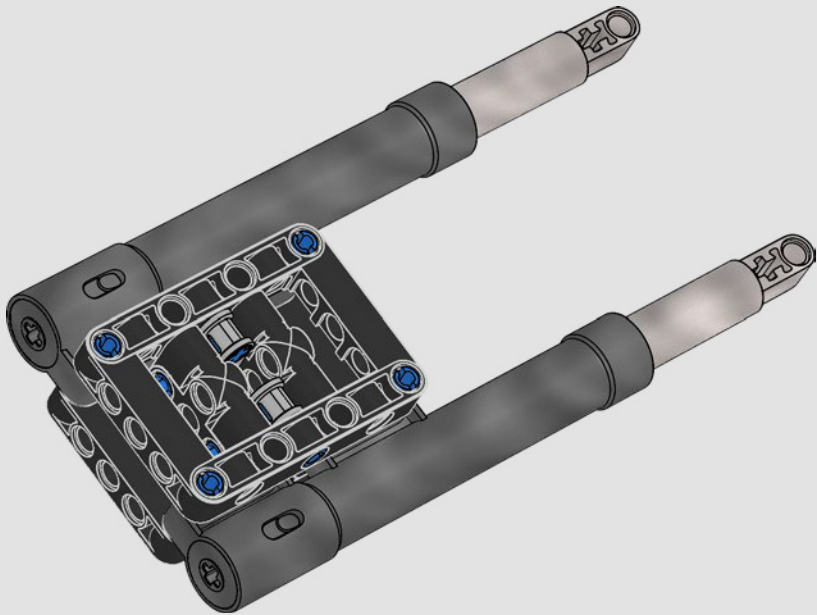

362

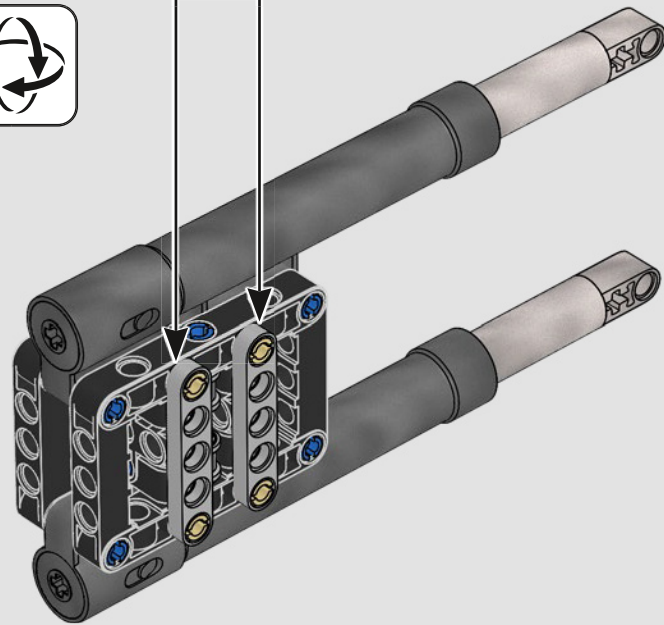
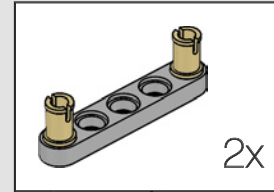
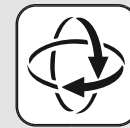

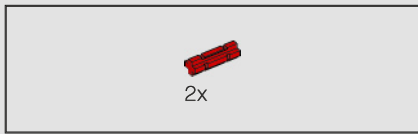

363

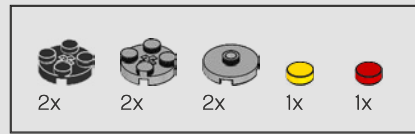
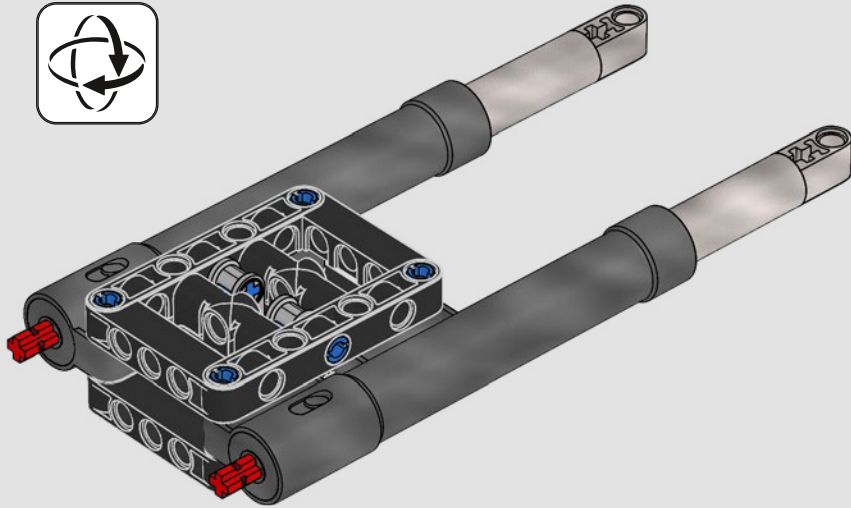

364

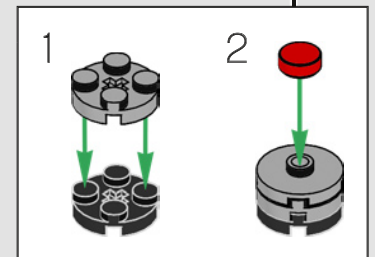
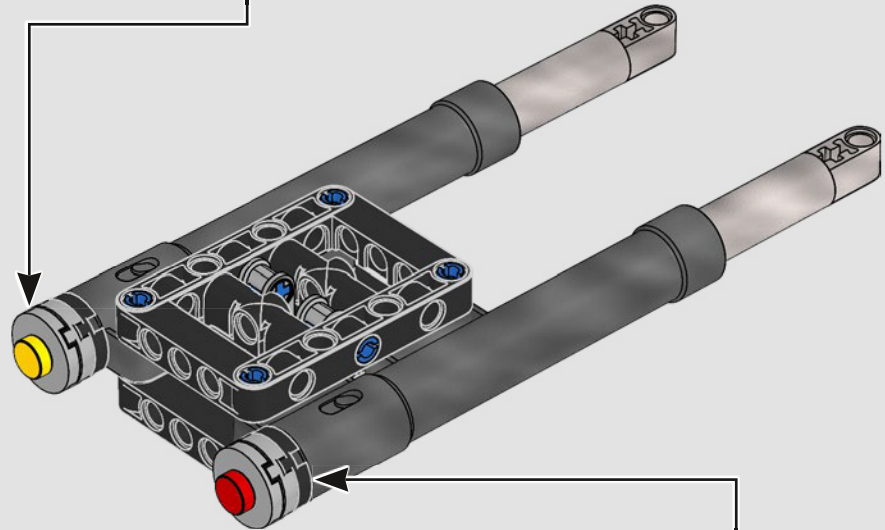
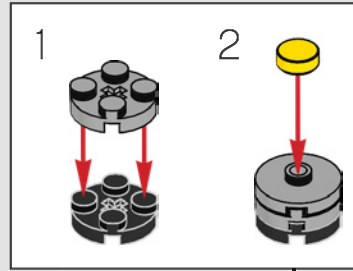



2x

365

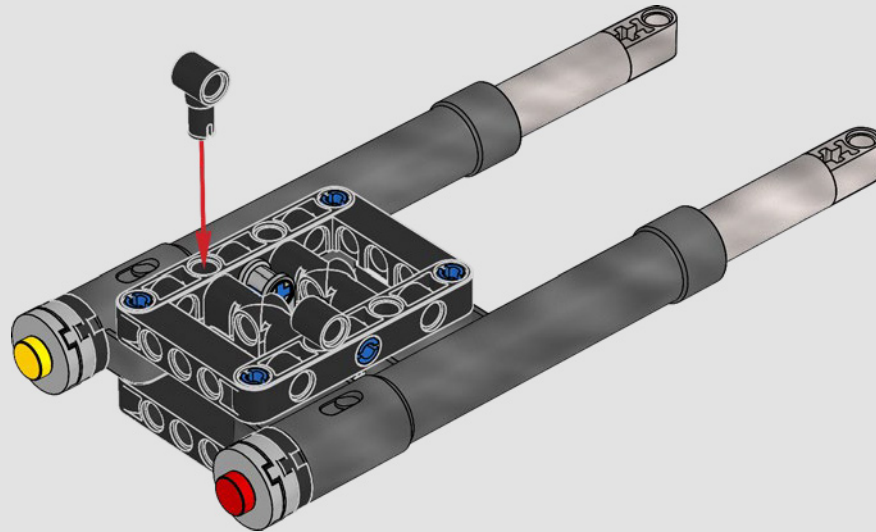

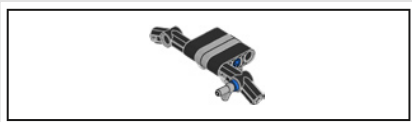

366

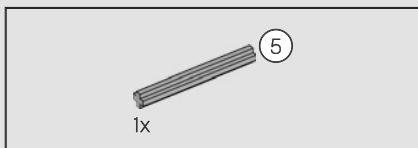
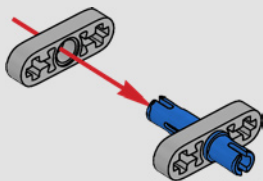

367

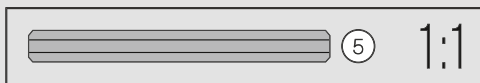
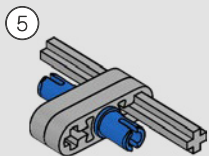

368

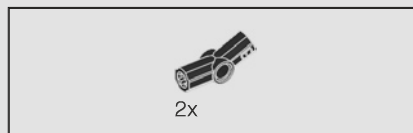
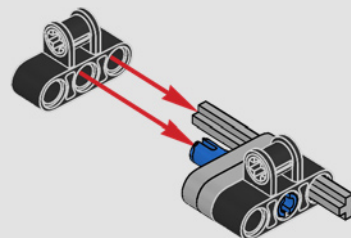

369

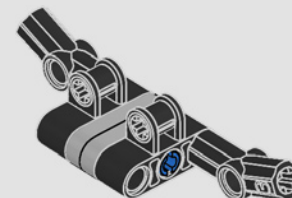
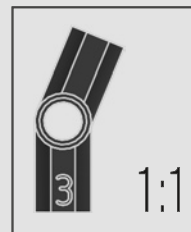

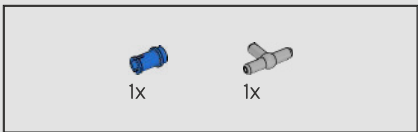

370

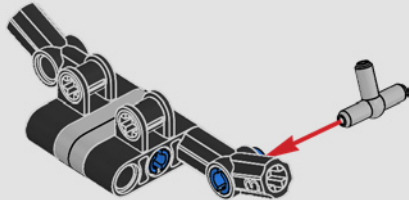

371

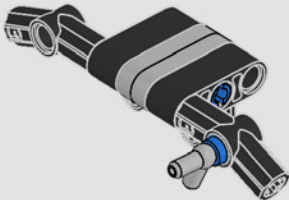

372

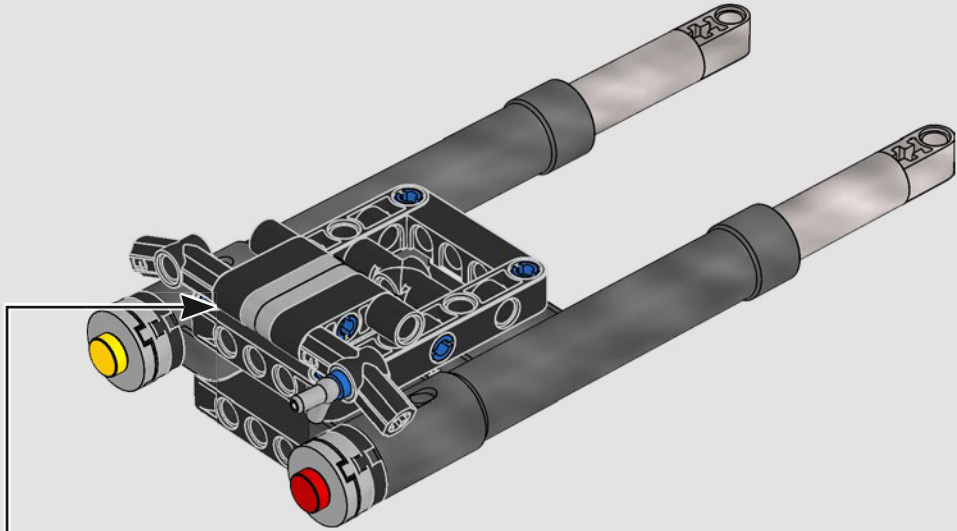

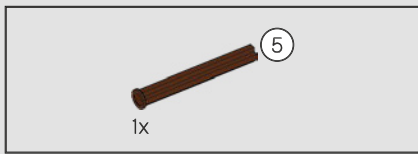

373

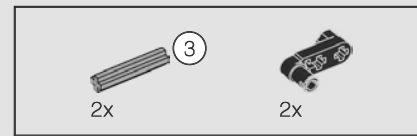
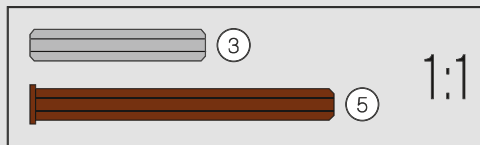
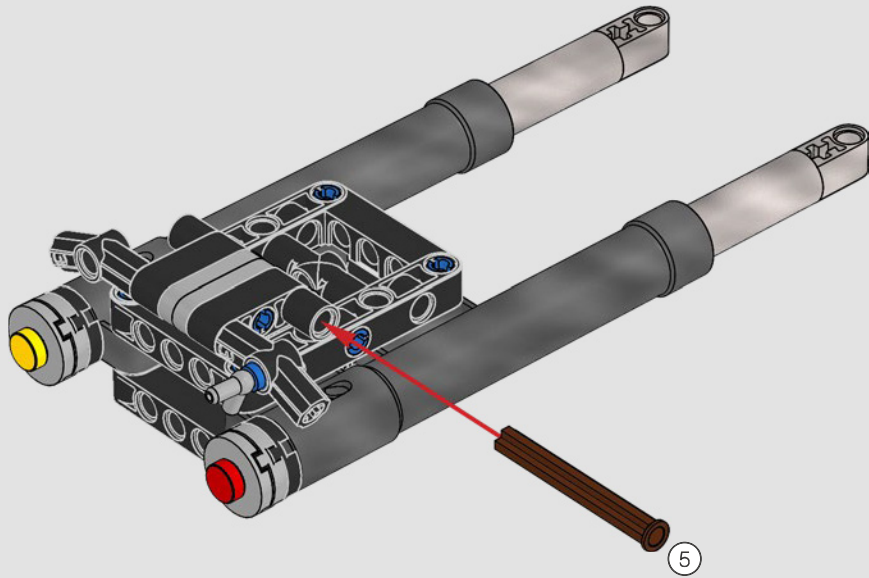

374

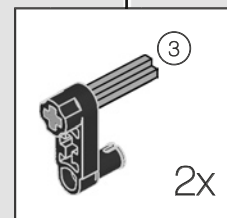
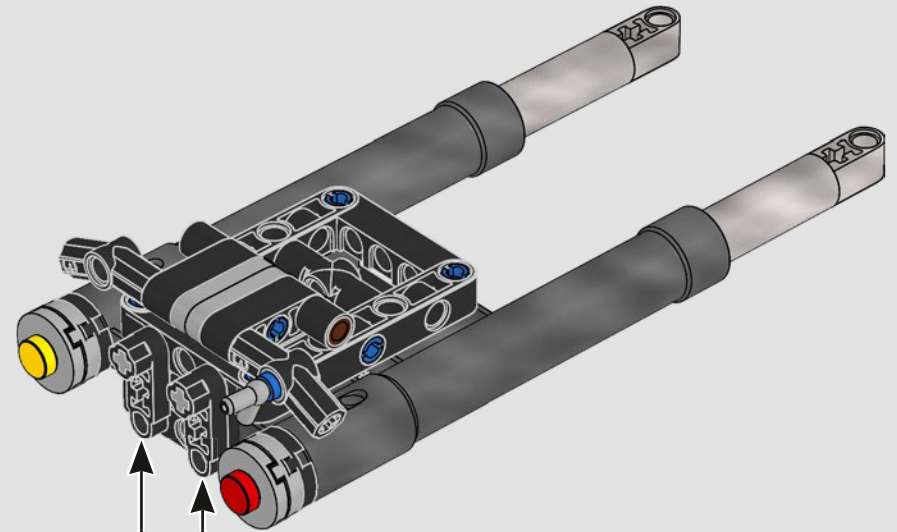

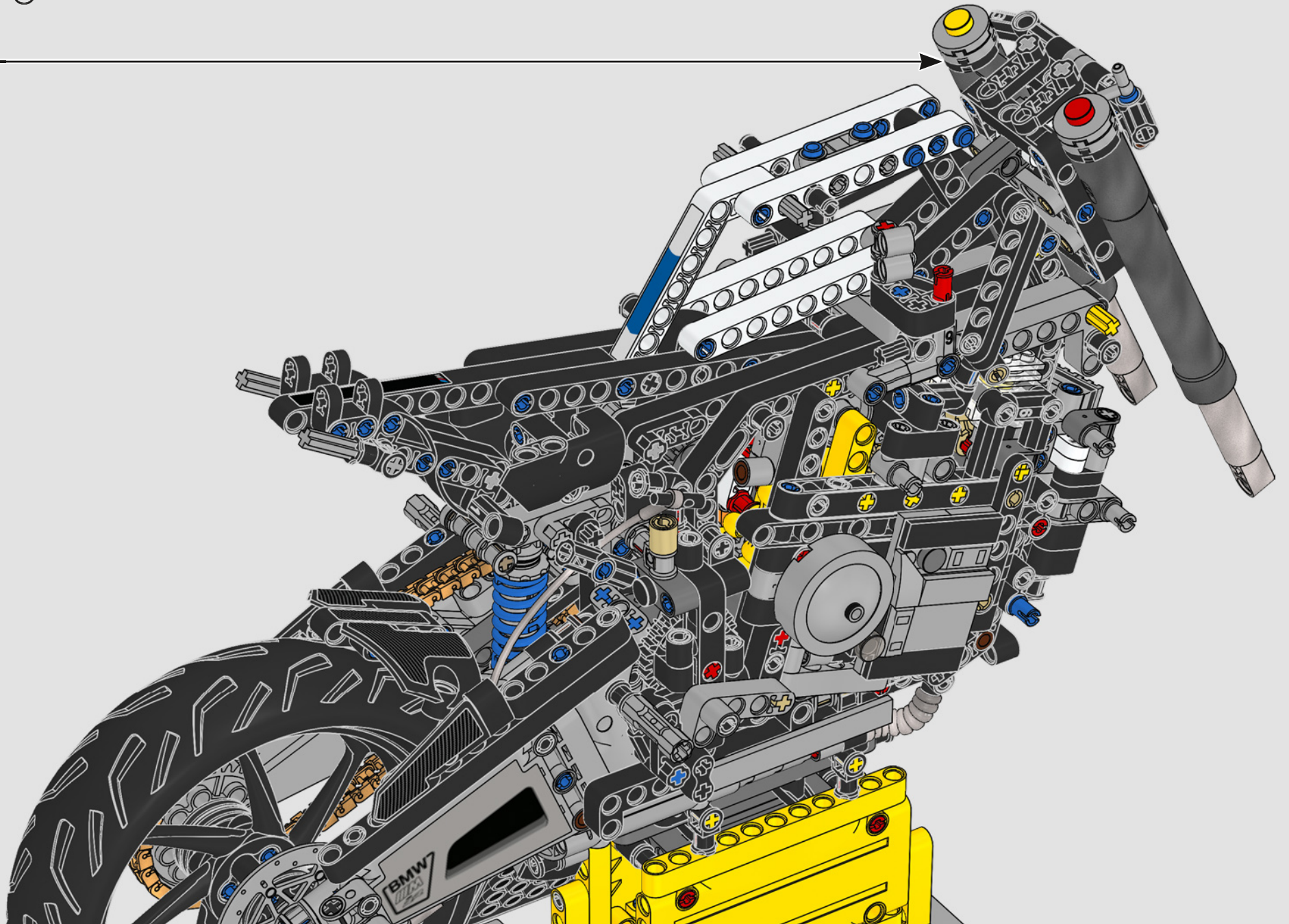

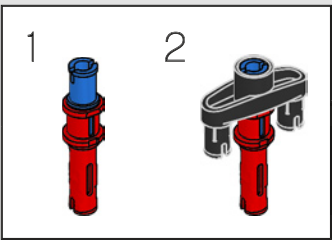
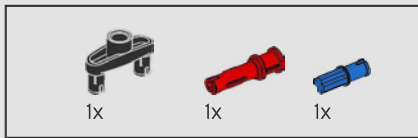

376

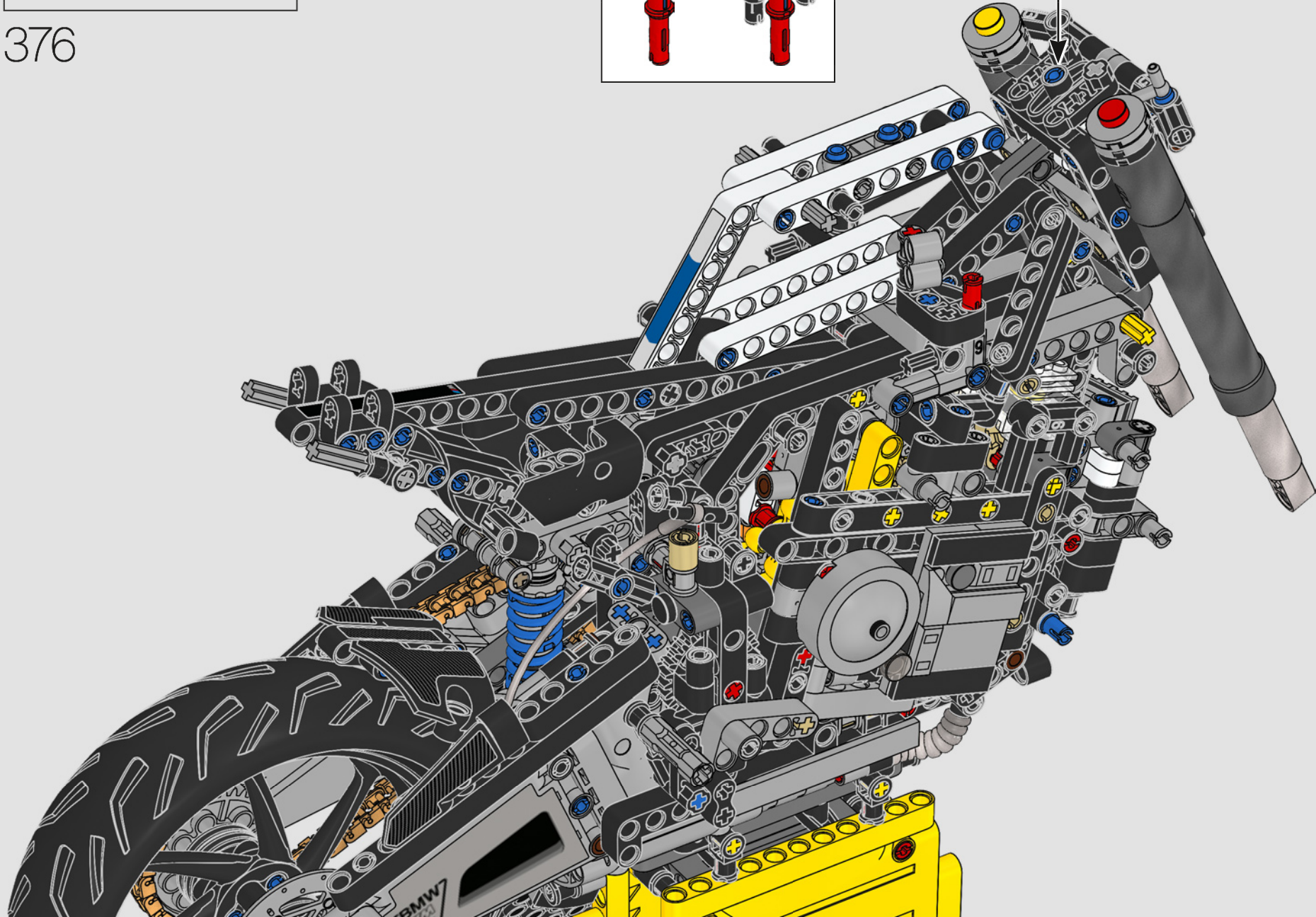

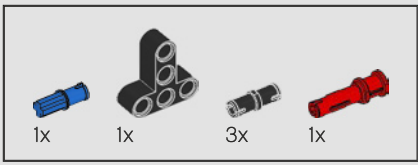

377

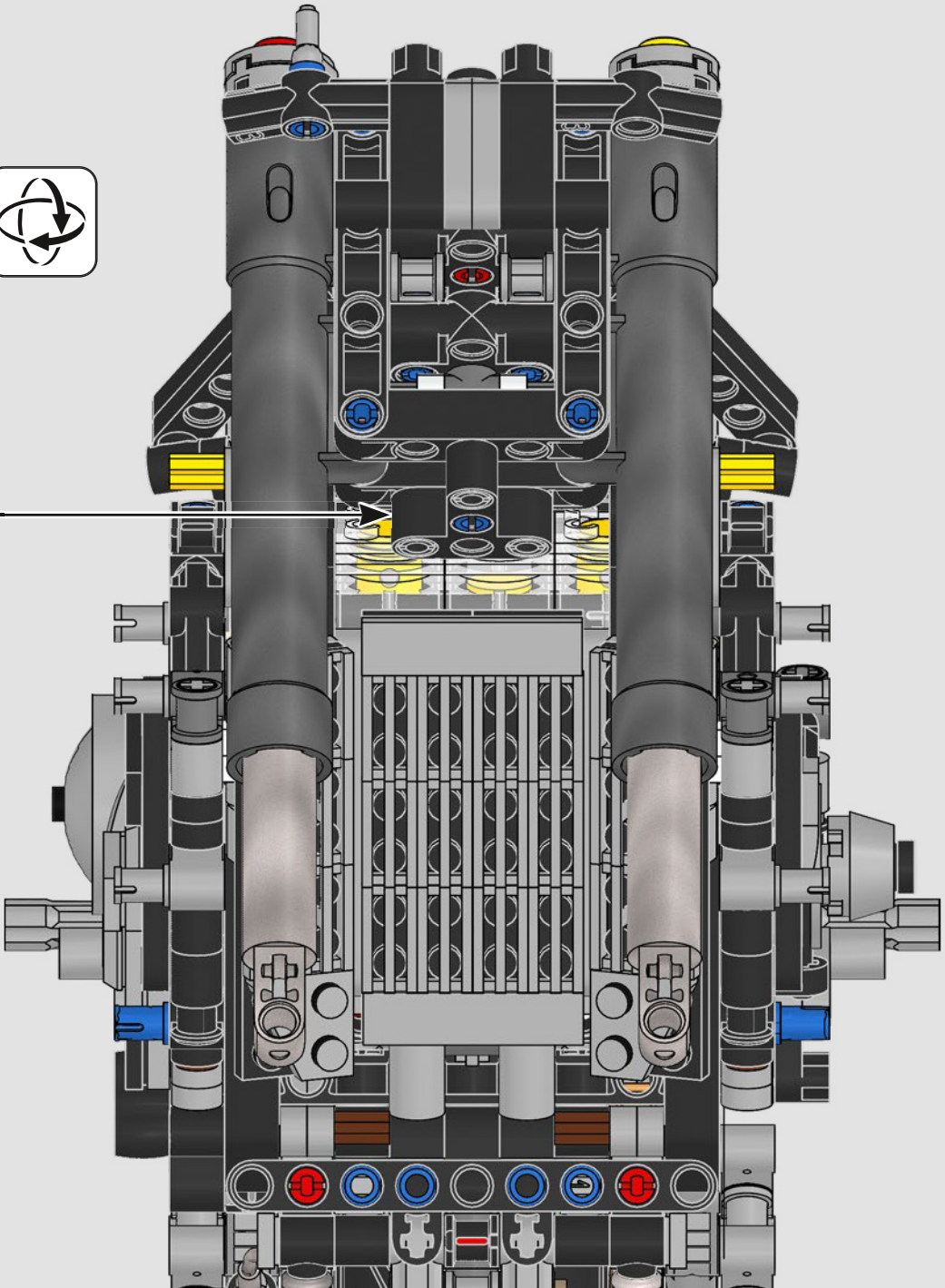
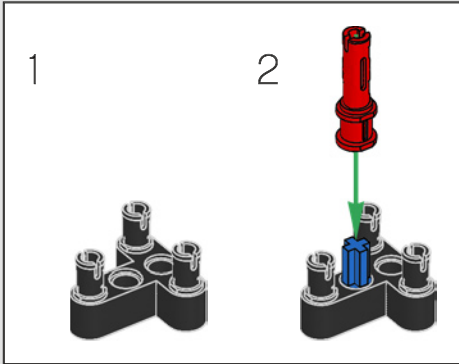

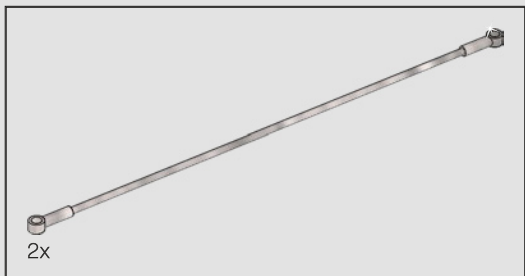

378

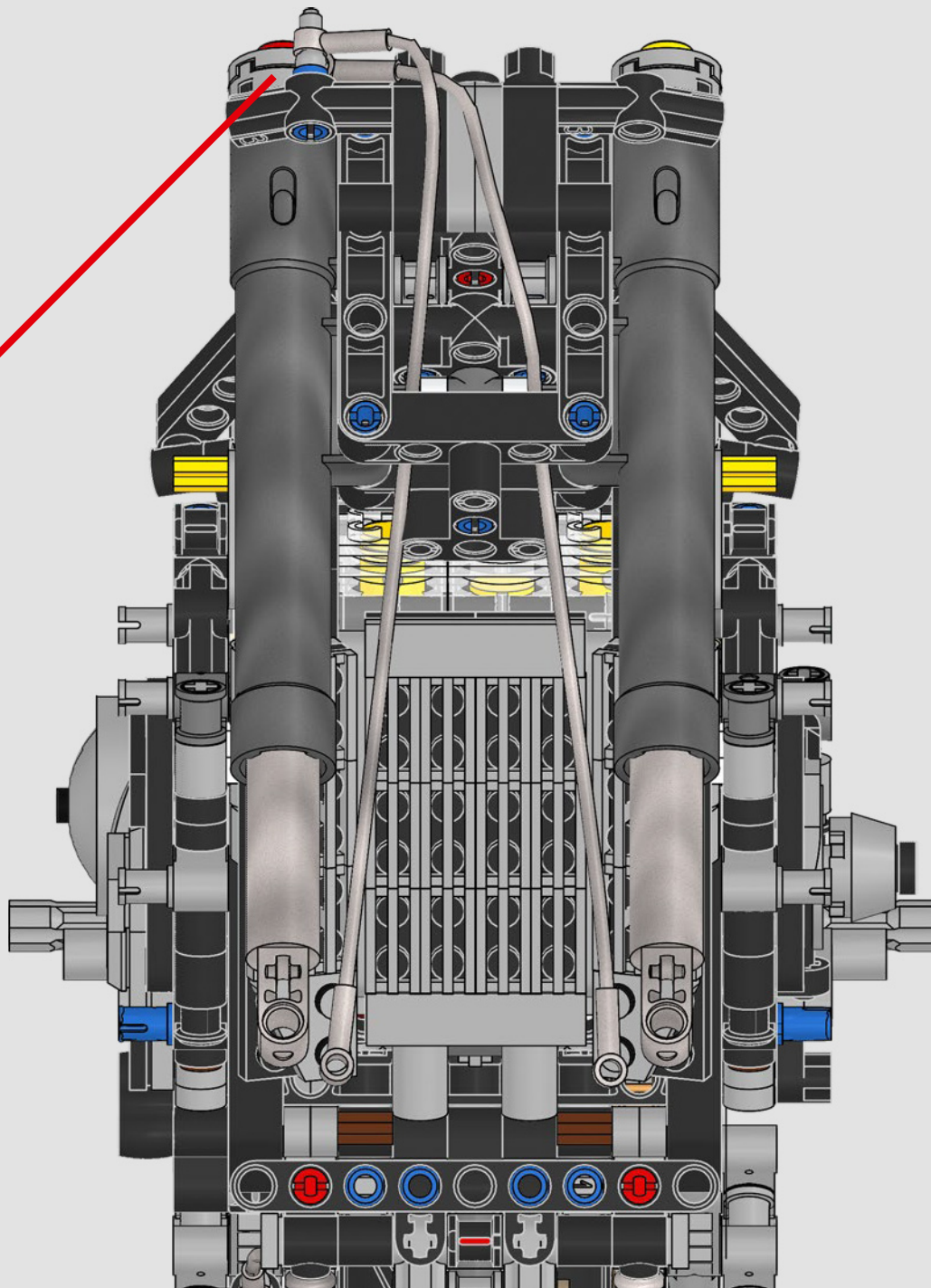
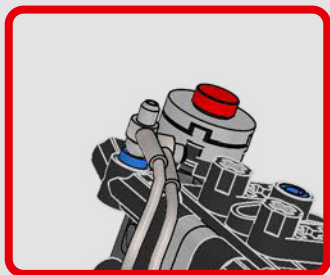

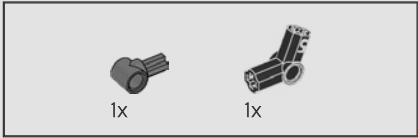
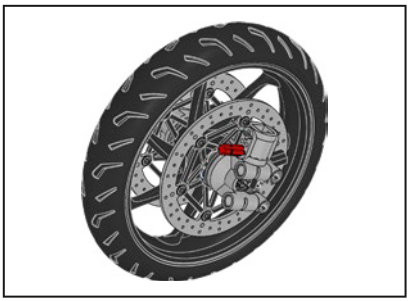

379

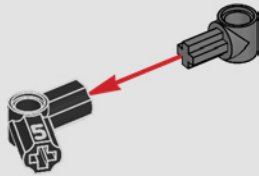

380



381

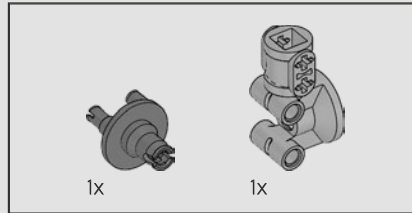
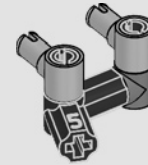

382

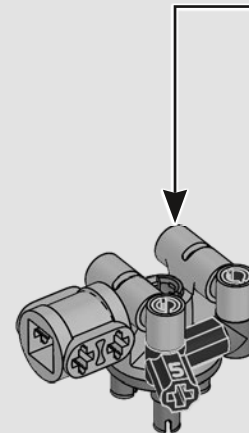
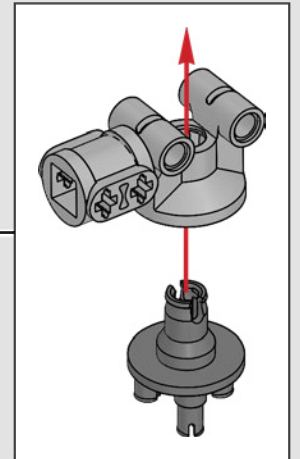

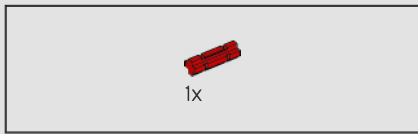

383

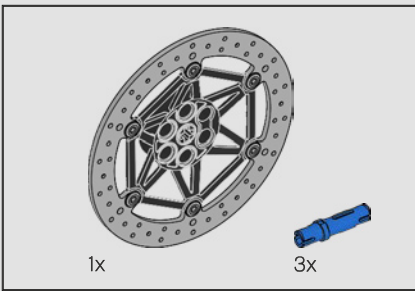
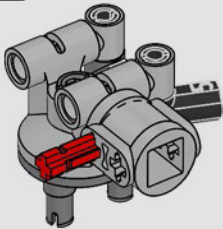

384

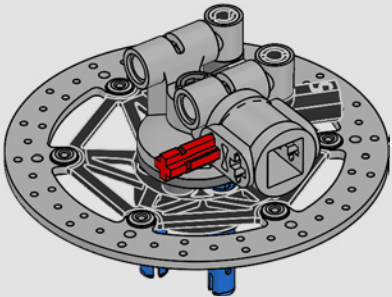
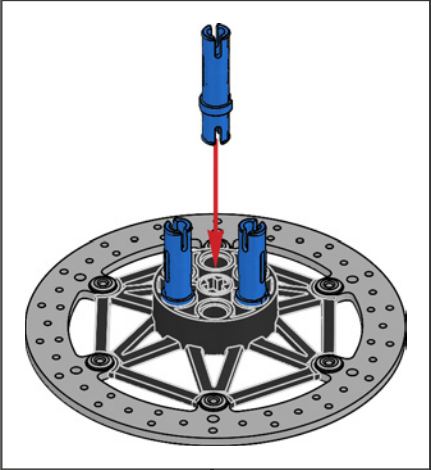

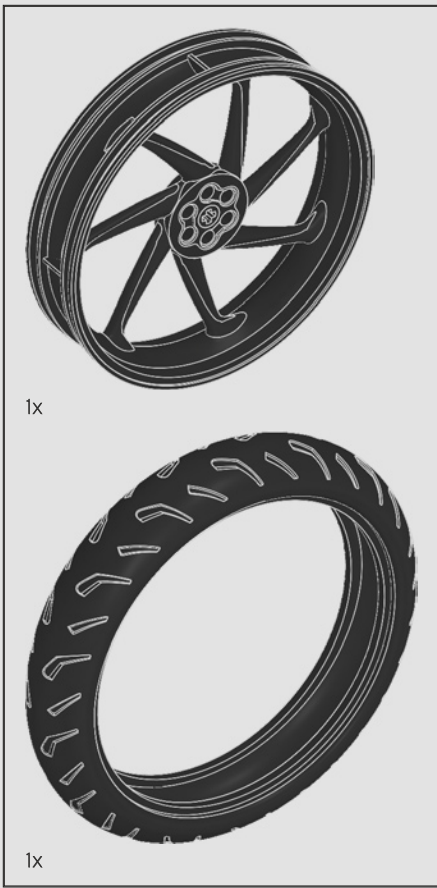

1x

1x

385

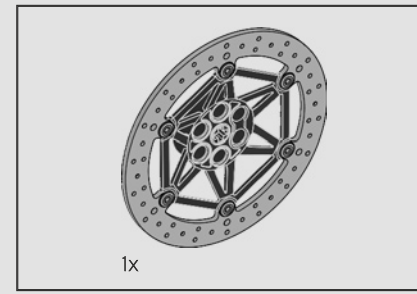
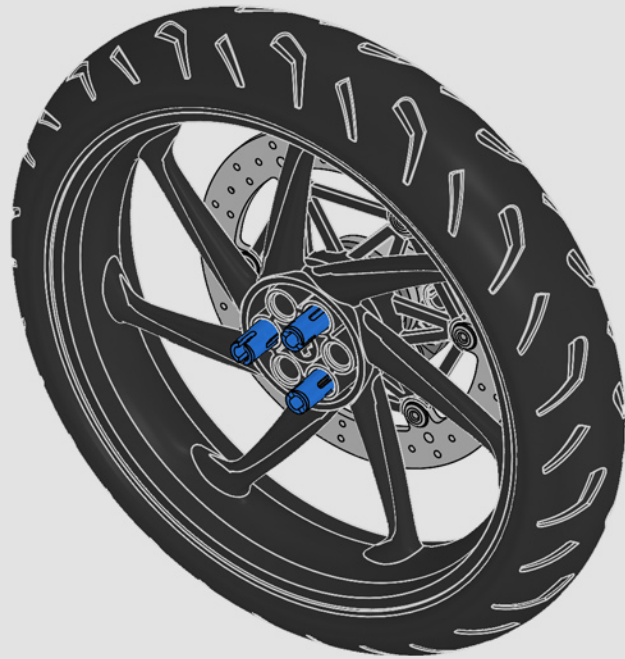

1x

386



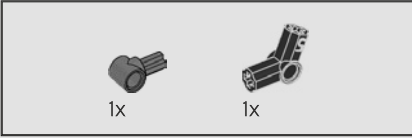
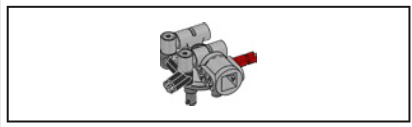

387

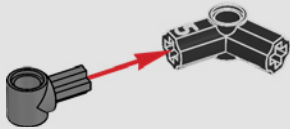

388

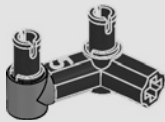

389

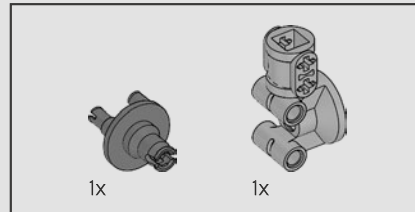
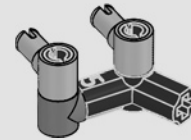

390

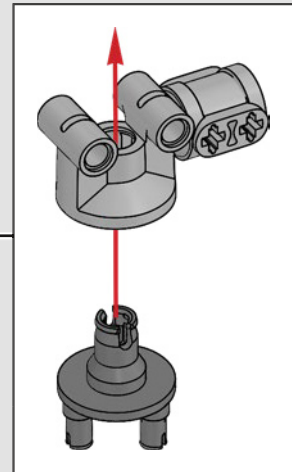
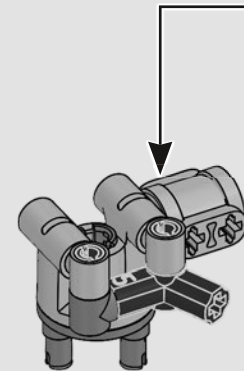



1x

391

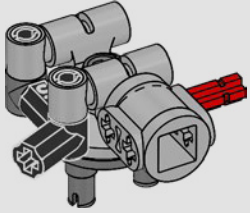



392

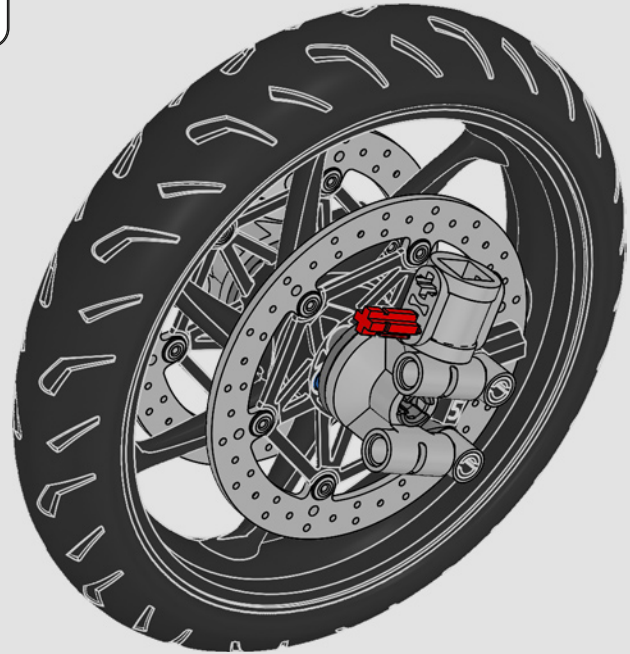

393

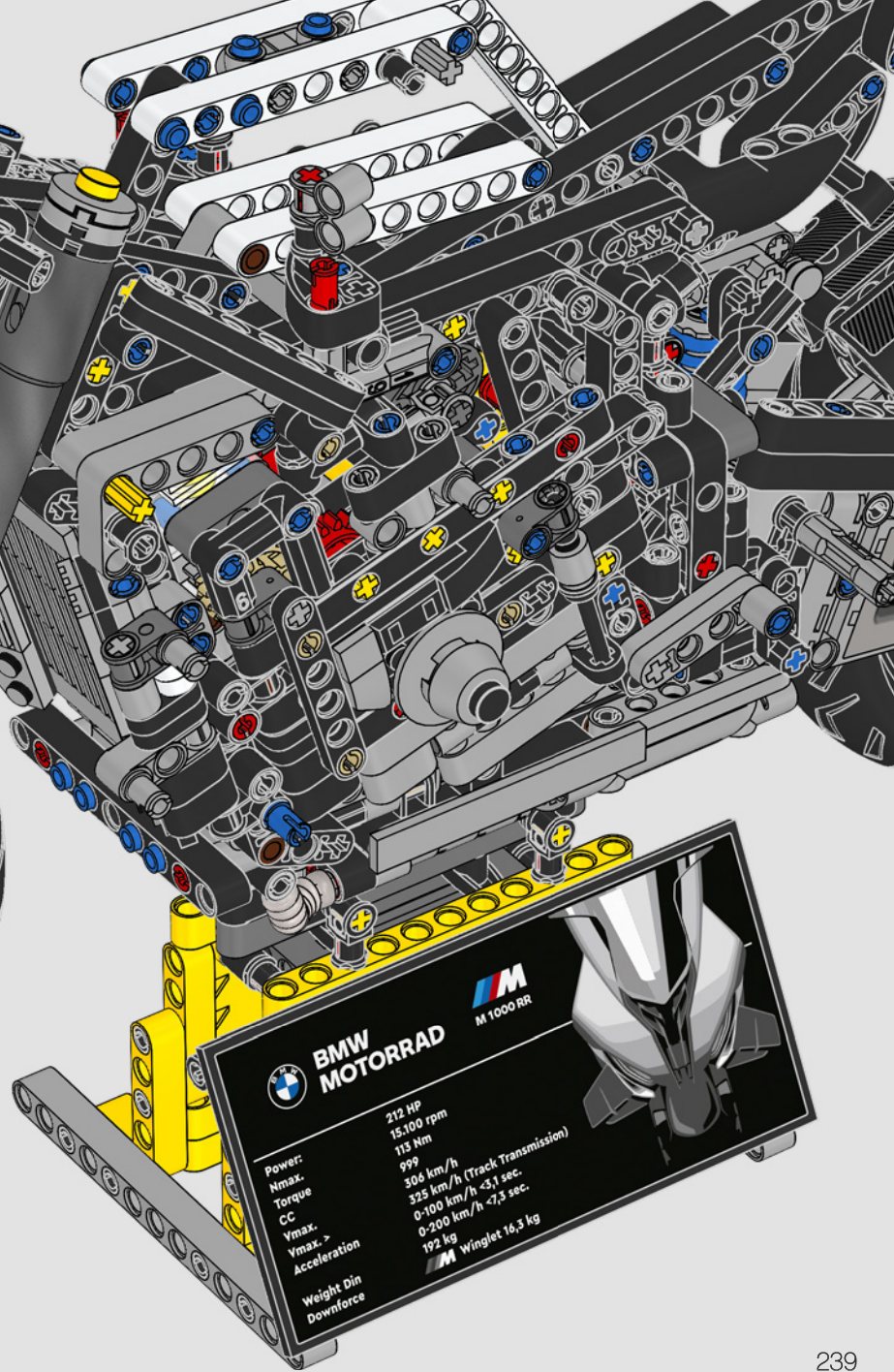
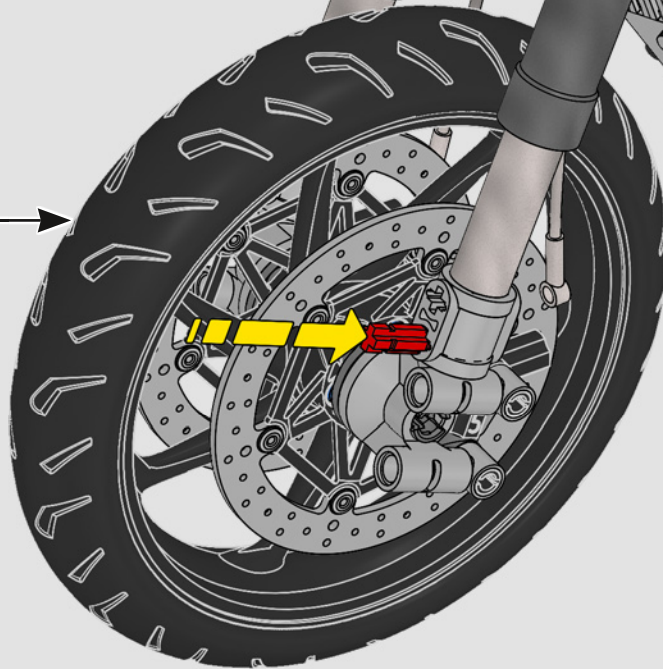
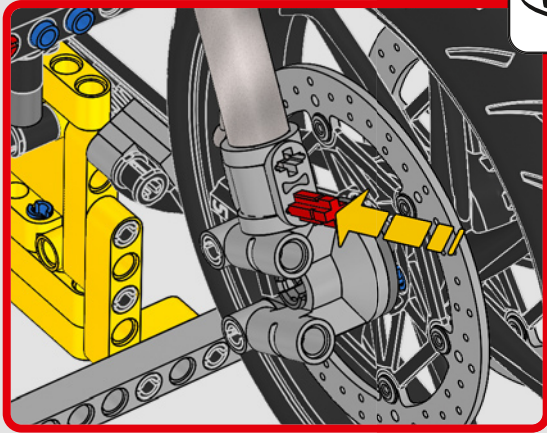



BMW MOTORRAD  **M 1000 RR**

Power:	212 HP
Nmax:	15,100 rpm
Torque	113 Nm
CC	999
Ymax.	306 km/h
Acceleration	325 km/h (<math><3.1\text{ sec.}</math>)
Weight: Din	0-100 km/h <math><7.3\text{ sec.}</math>
Downforce	192 kg
	Winglet 16,3 kg



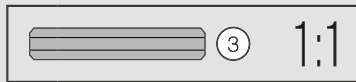
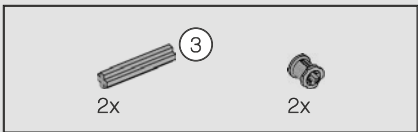

395

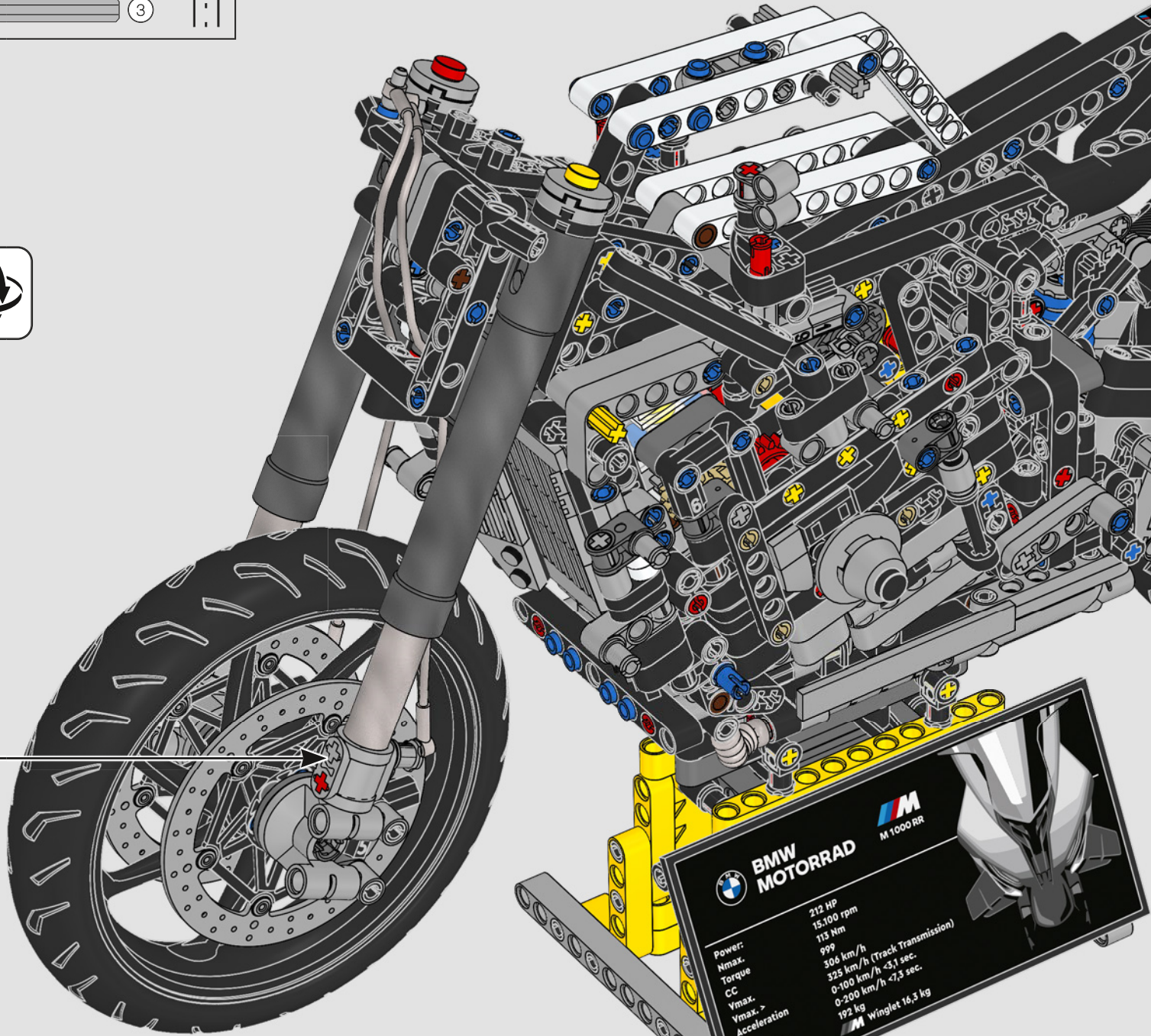
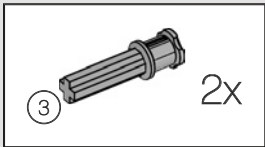
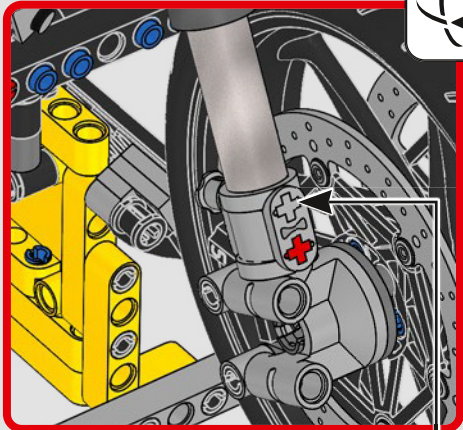

BMW MOTORRAD M 1000 RR

Power:	212 Hp
Nmax:	15.100 rpm
Torque:	113 Nm
CC:	999
Vmax:	306 km/h
Acceleration:	0-100 km/h <3> sec.
	0-200 km/h <7,3> sec.
Weight Din:	192 kg
Force:	Winglet 16,3 kg



396



397

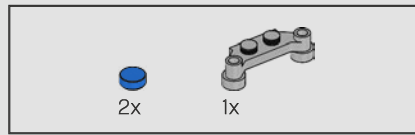

398

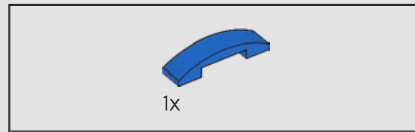
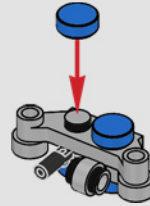

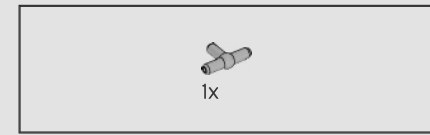
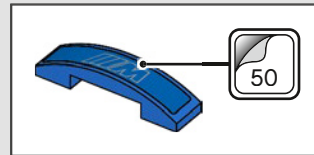

399

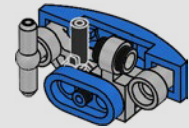
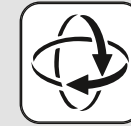

400

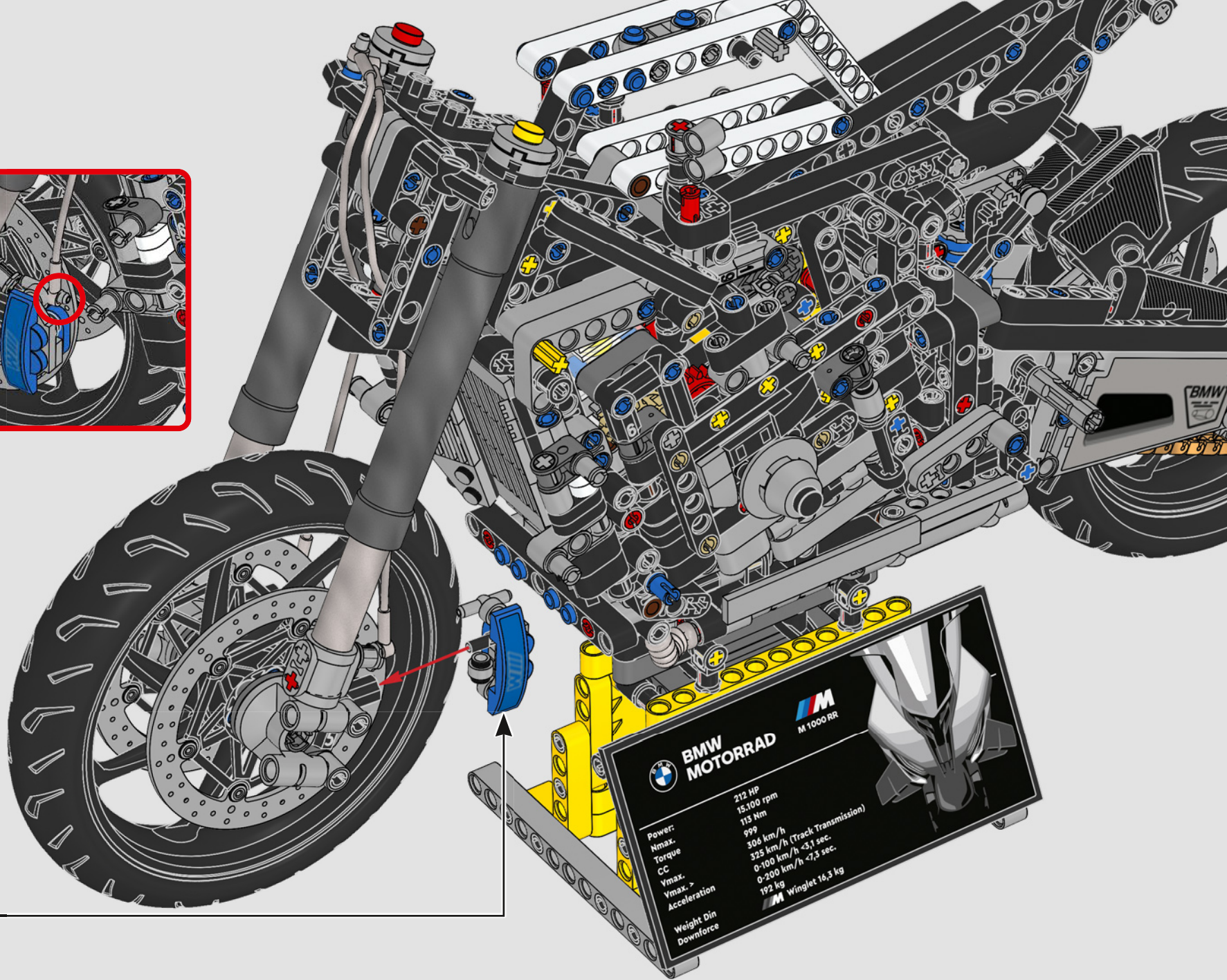
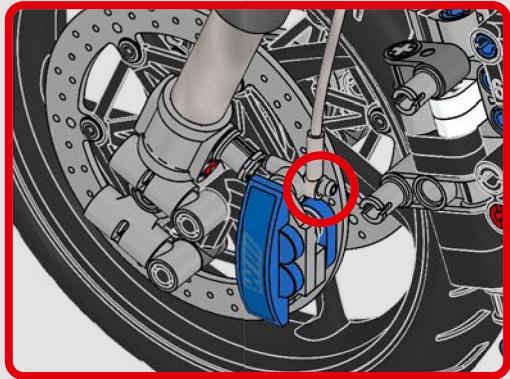



BMW MOTORRAD  **M 1000 RR**

Power:	212 HP
Nmax:	15,100 rpm
Torque:	115 Nm
CC	999
Vmax.	306 km/h (Track Transmission)
Acceleration	0-100 km/h <3,1 sec.
	0-200 km/h <7,3 sec.
Weight Din	192 kg
Downforce	Winglet 16,3 kg





402



403

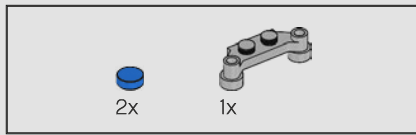

404

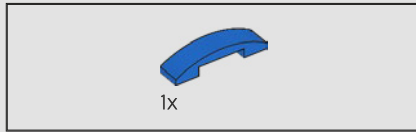
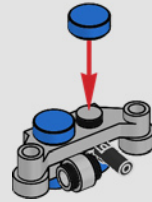

405

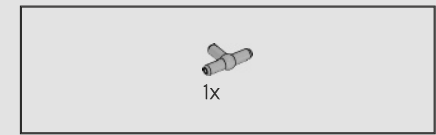
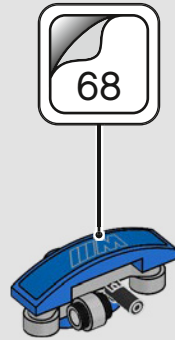

406

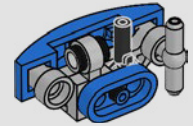

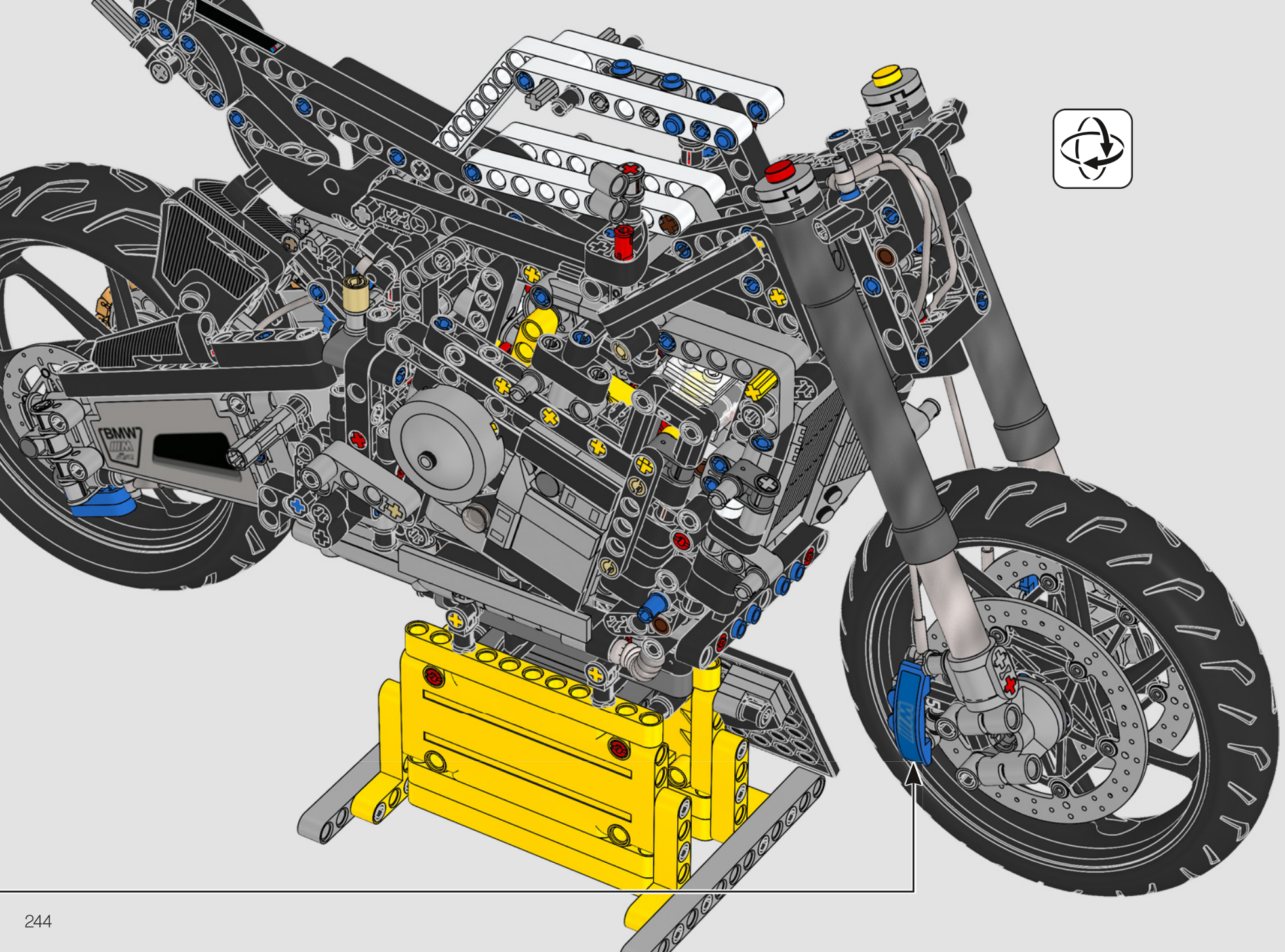

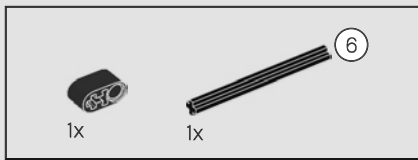

407

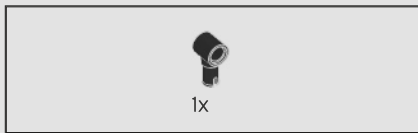
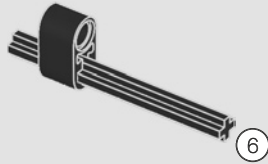

408

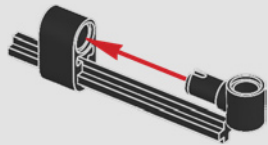

409

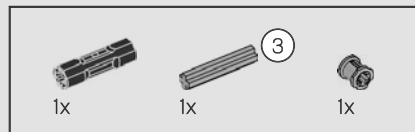
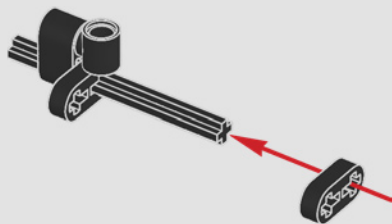

410

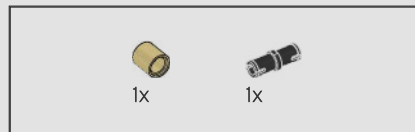
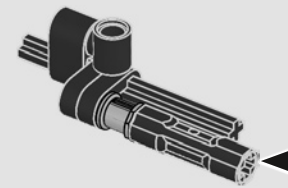
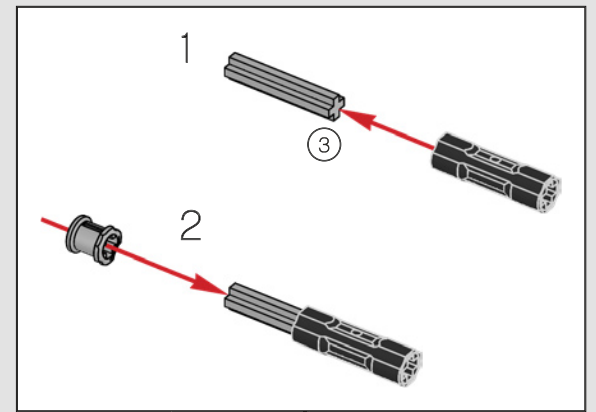

411

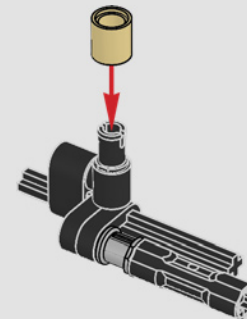

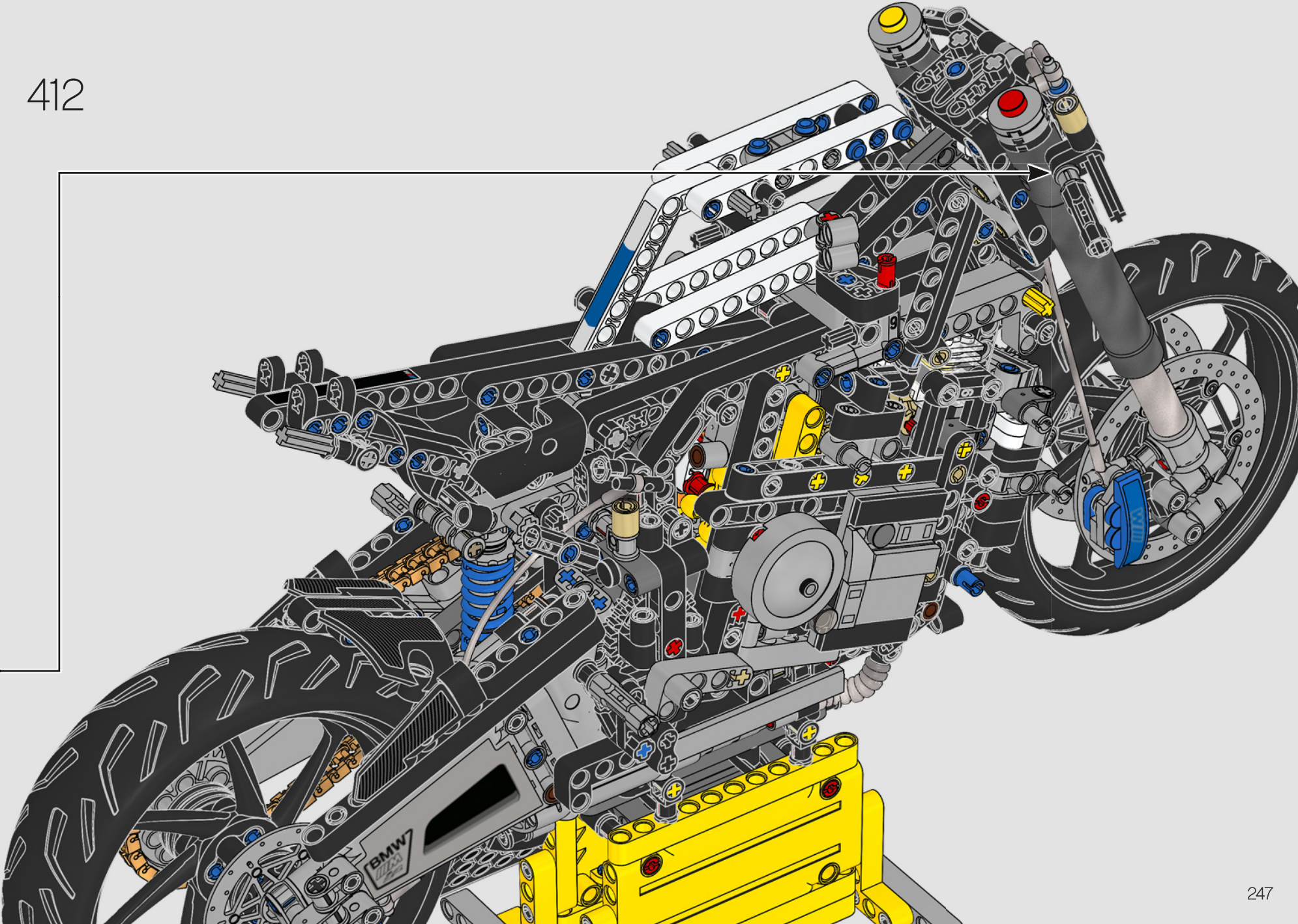

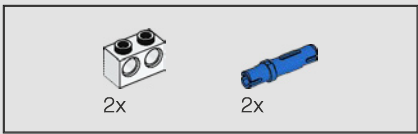

413

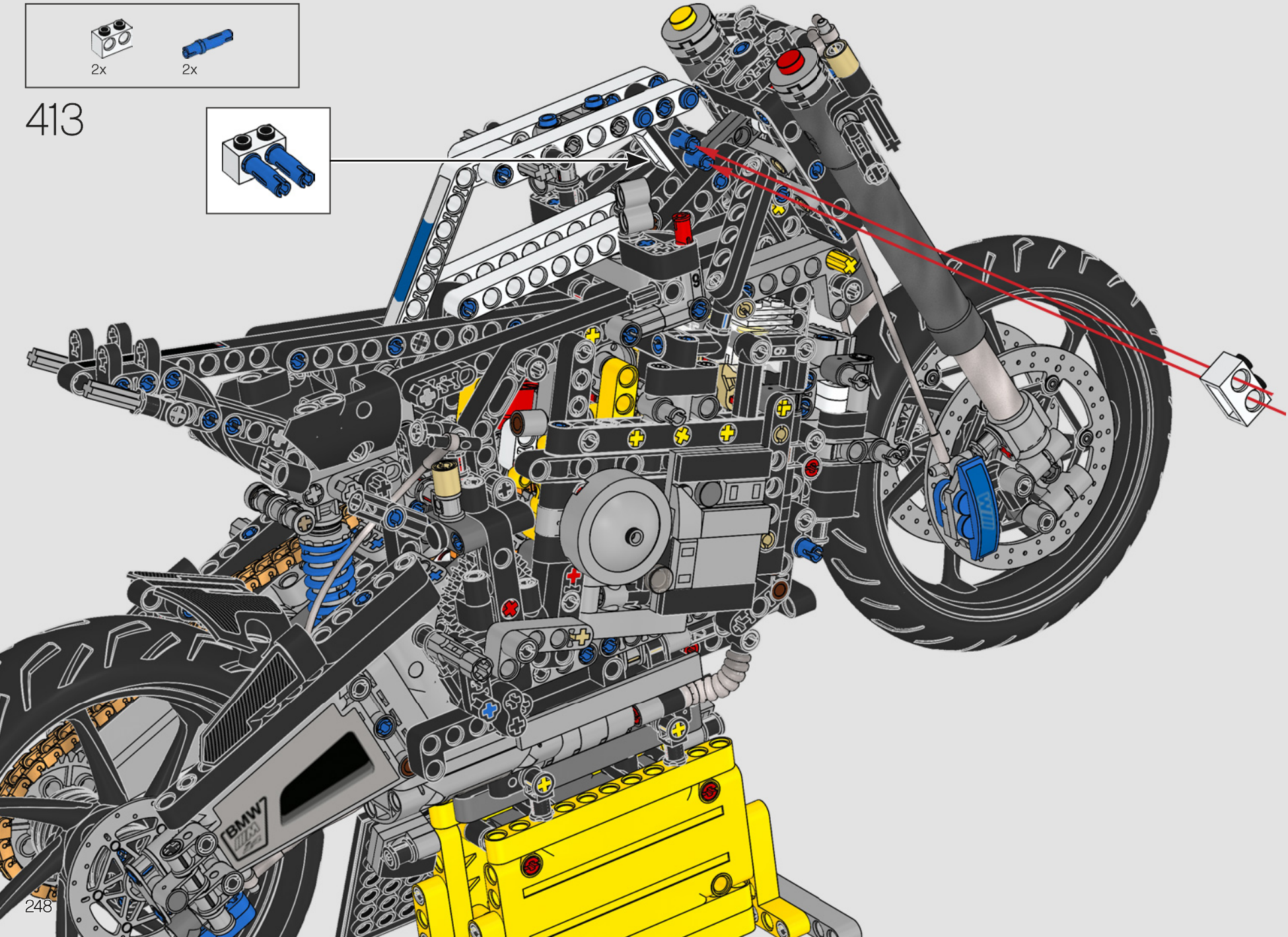
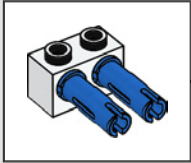

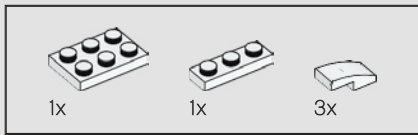

414

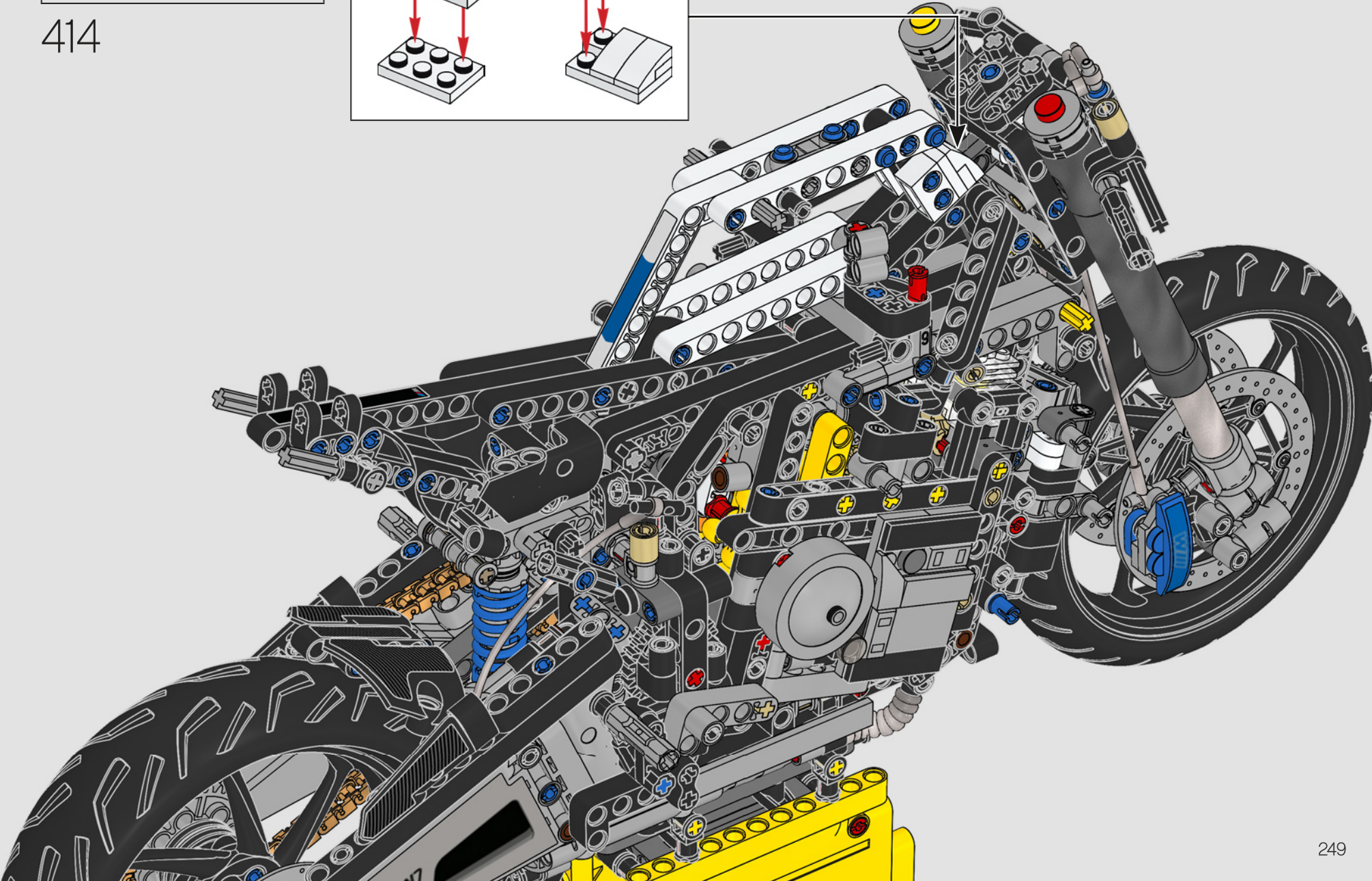
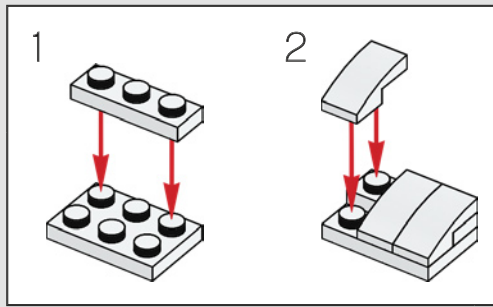

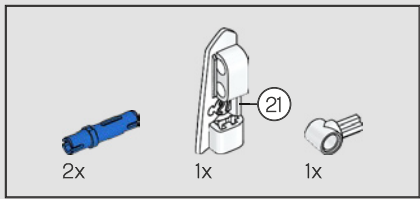

415

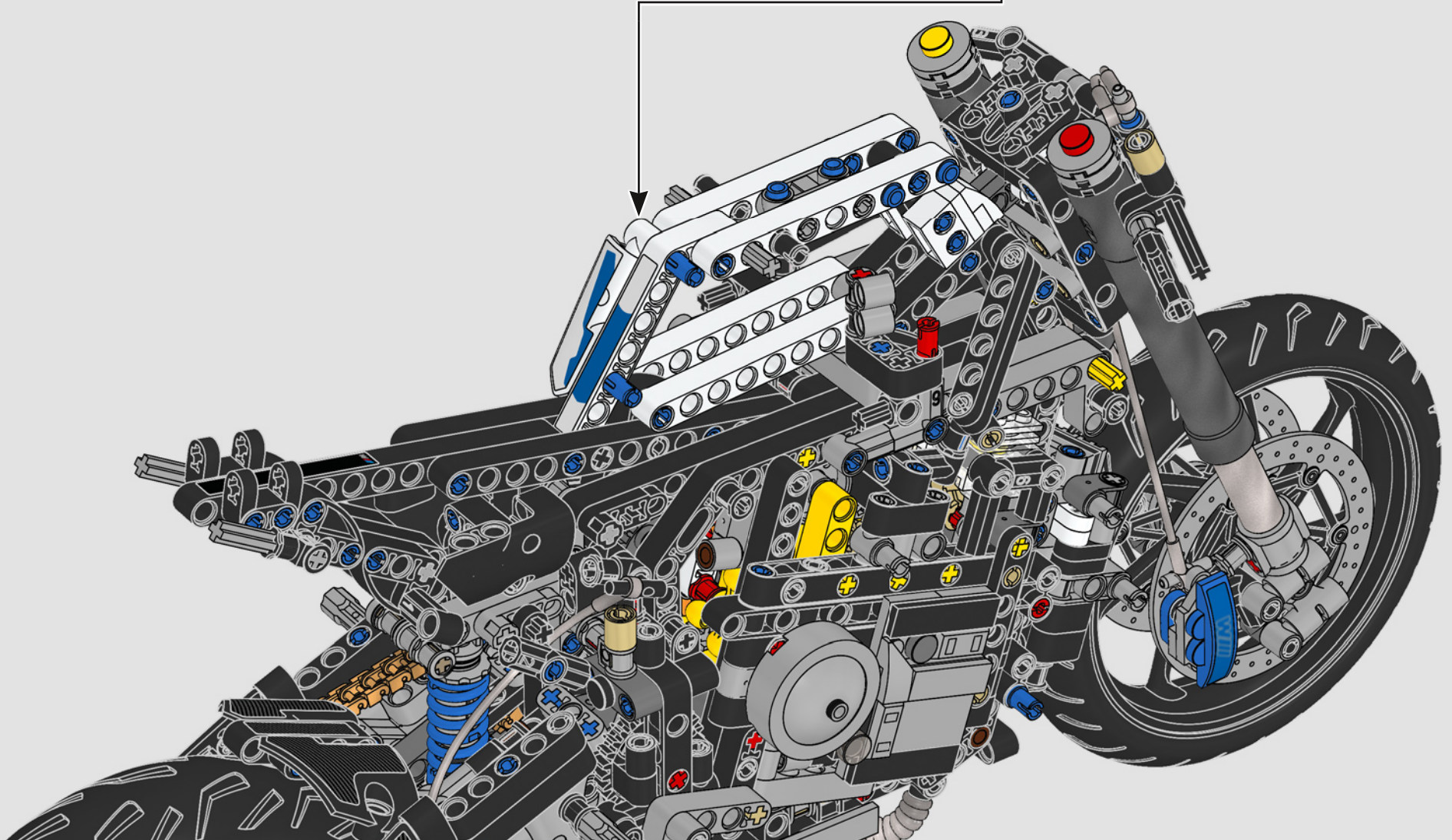
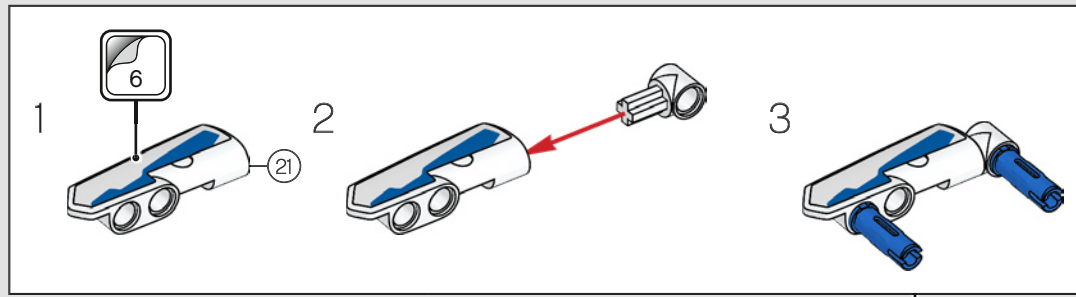

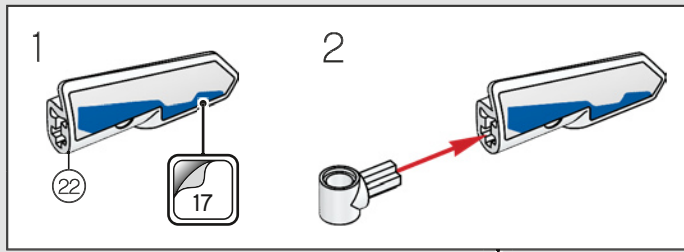
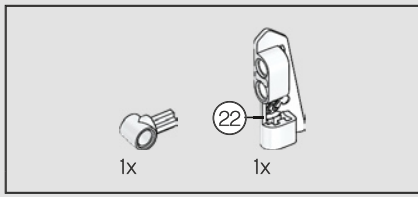

416

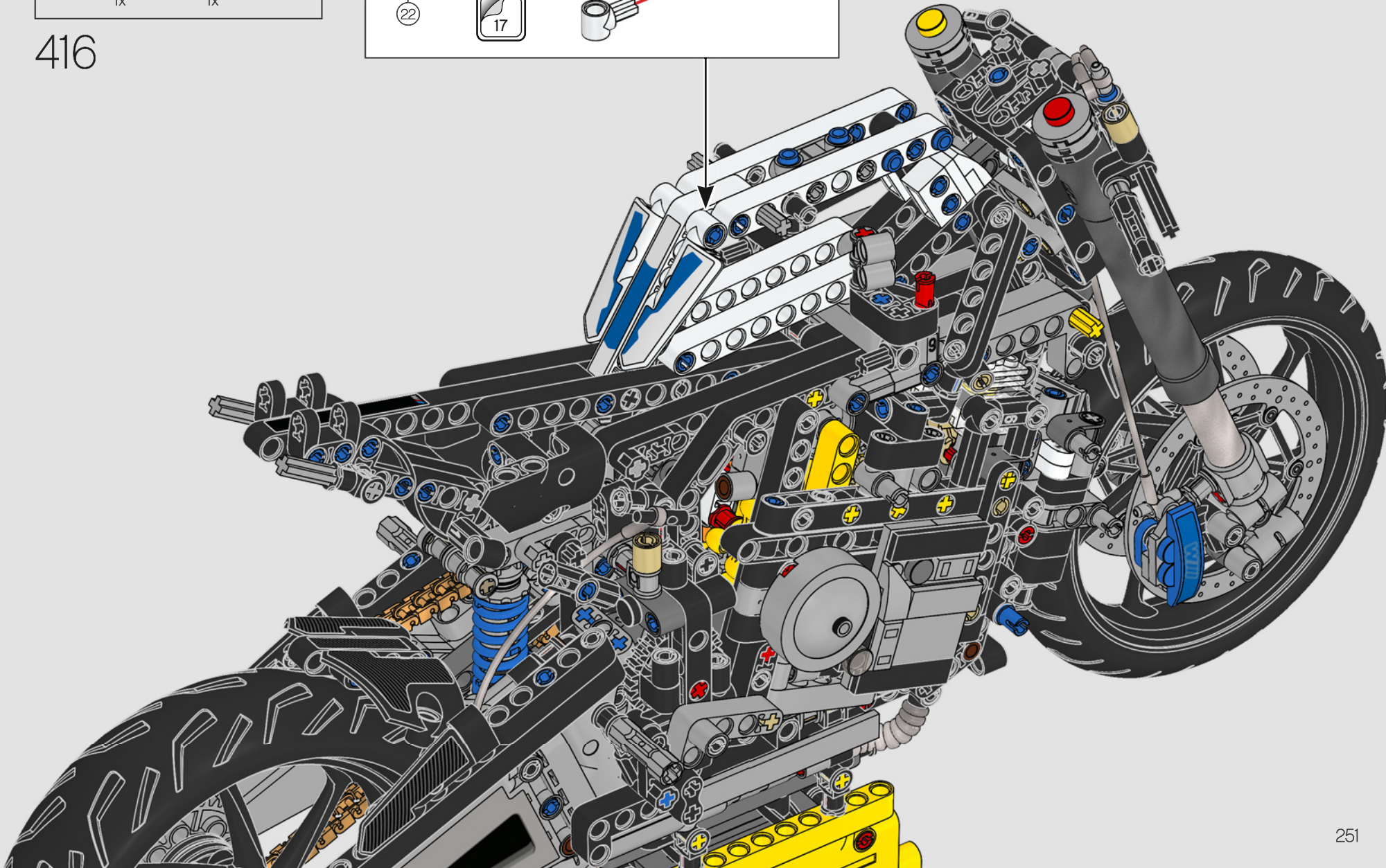

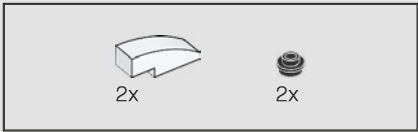

417

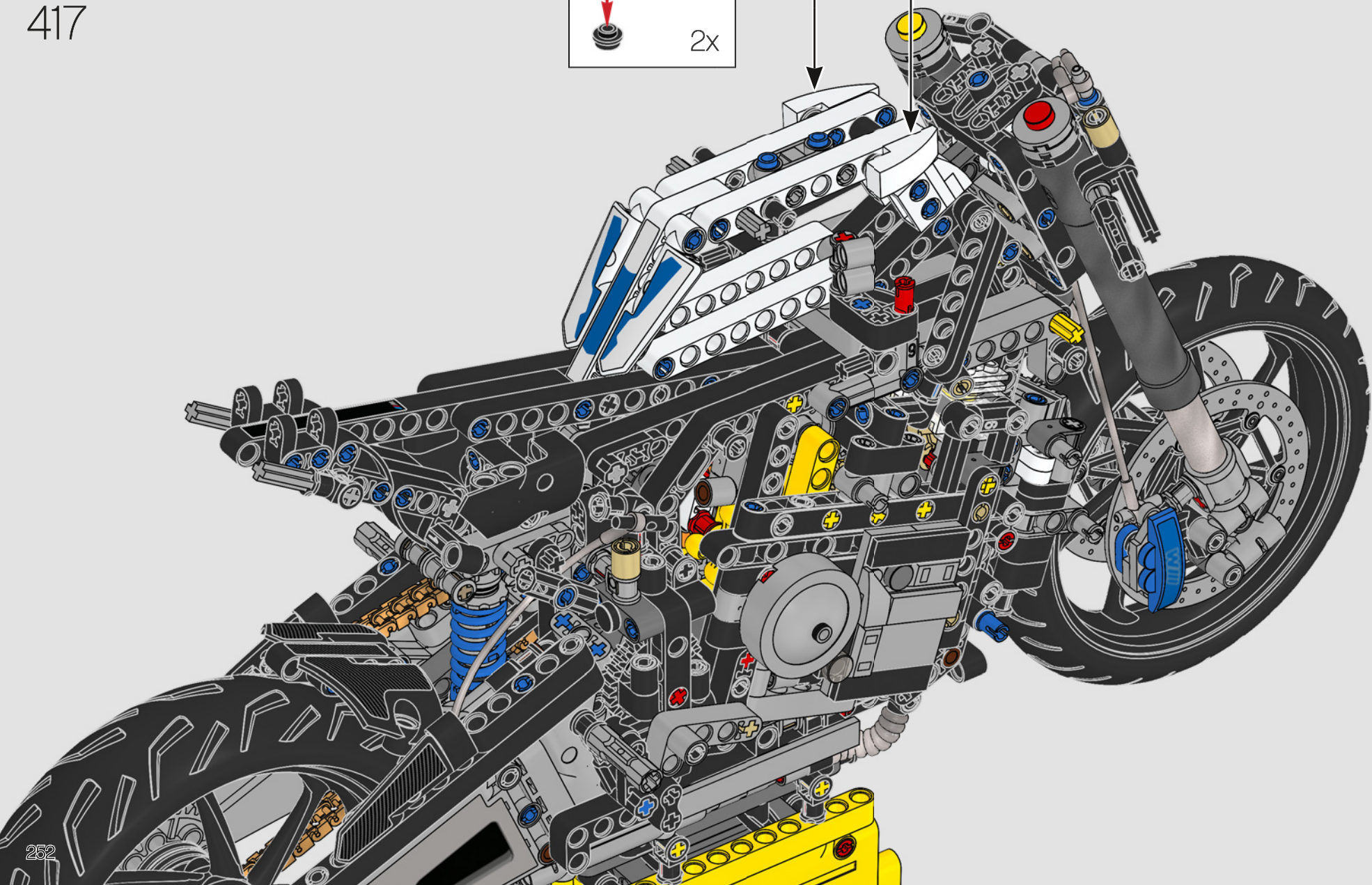
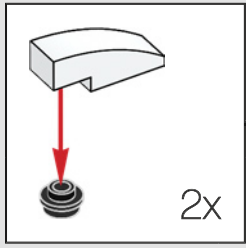



418

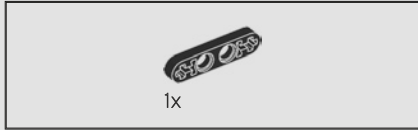

419

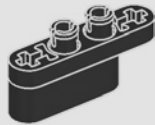

420

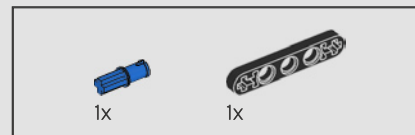
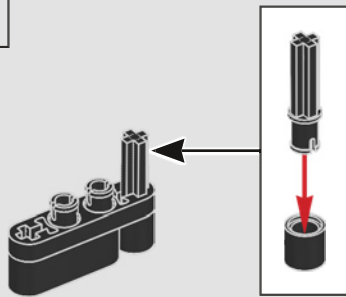

421

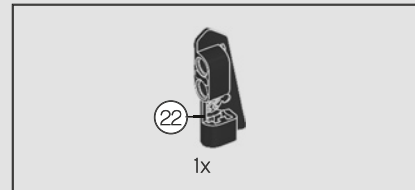
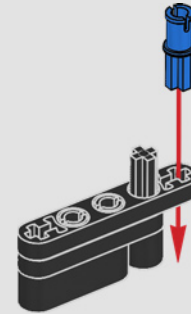

422

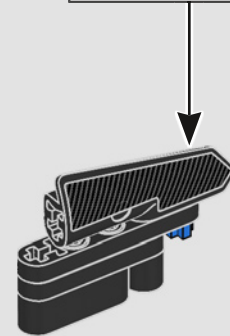
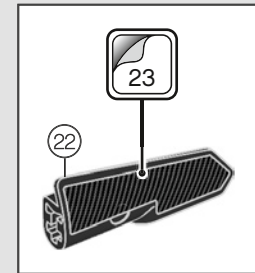

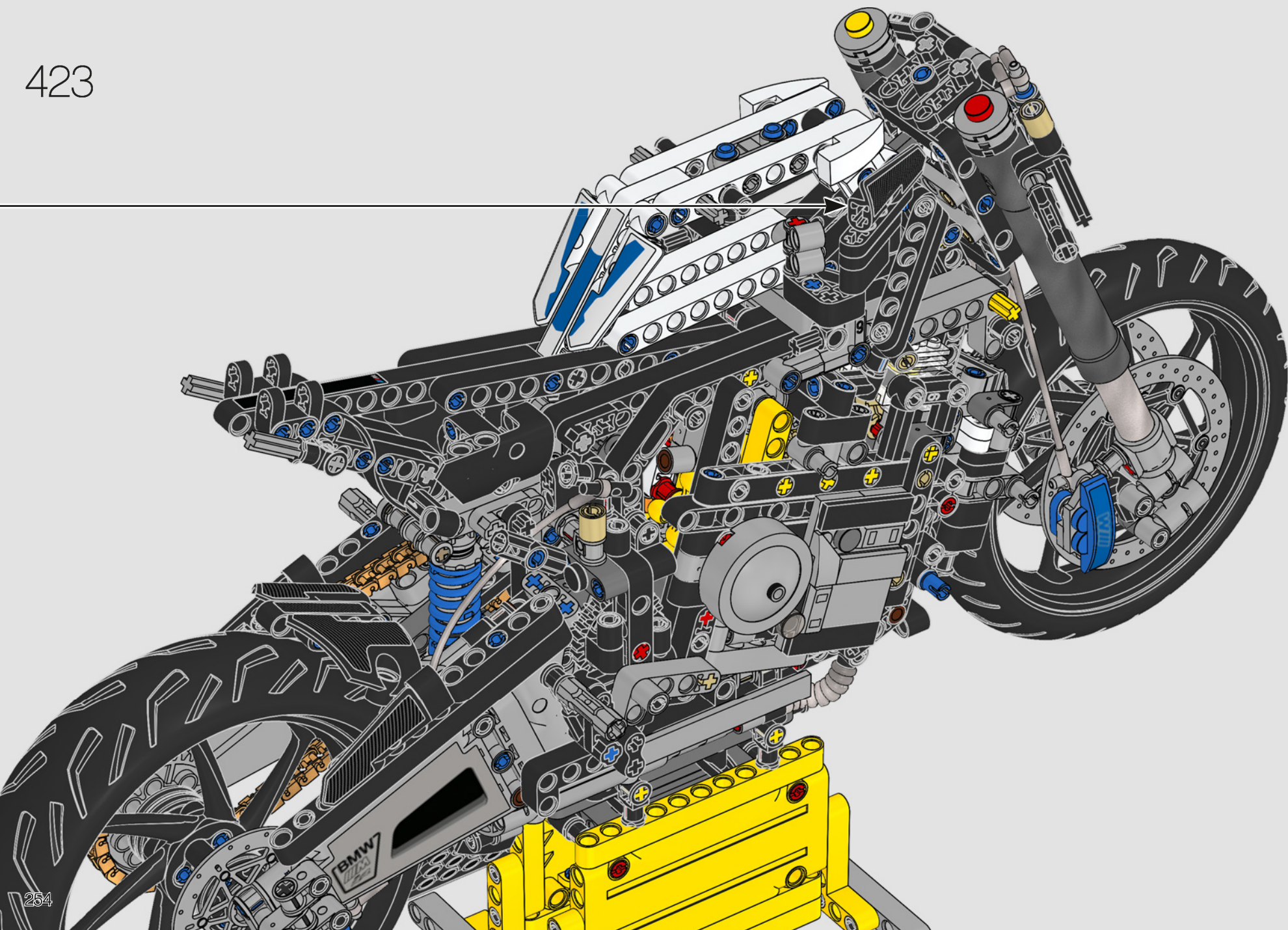

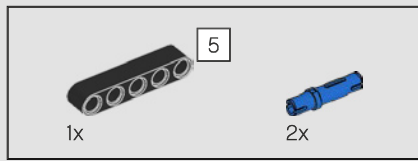

424

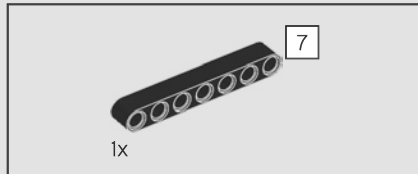
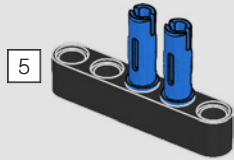

425

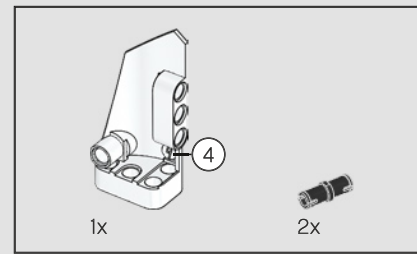
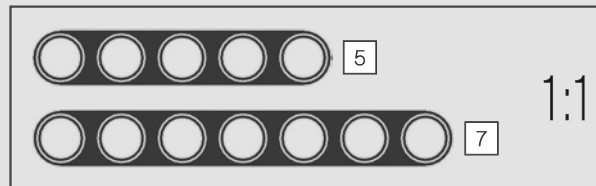
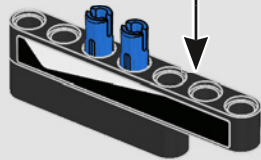
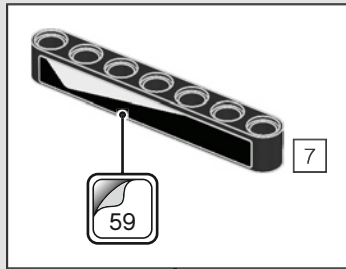

426

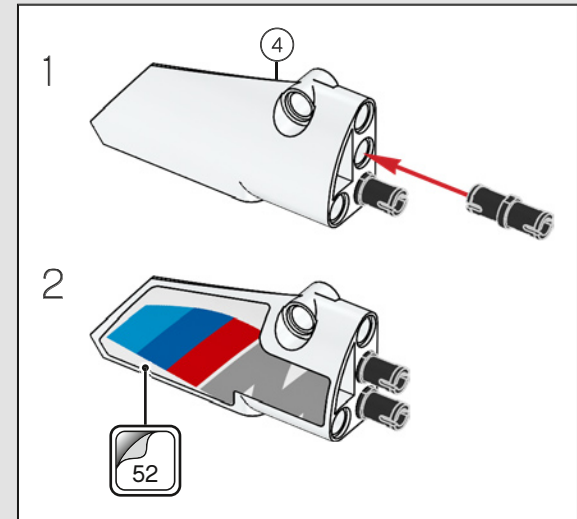

427

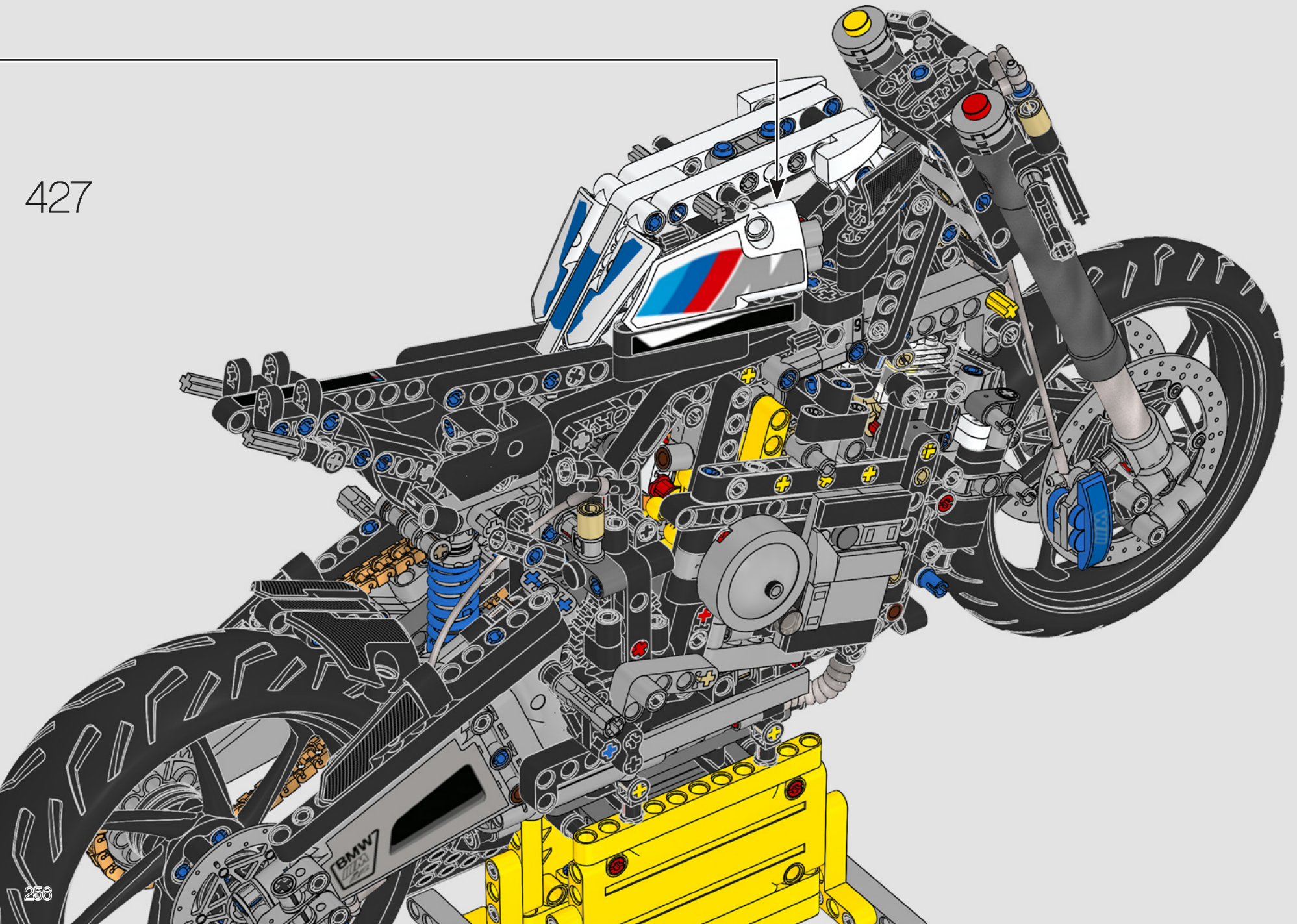

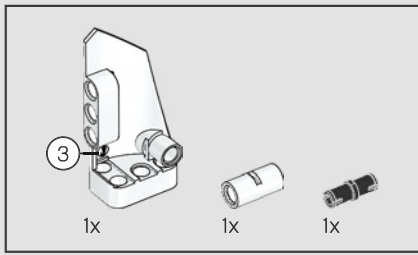

428

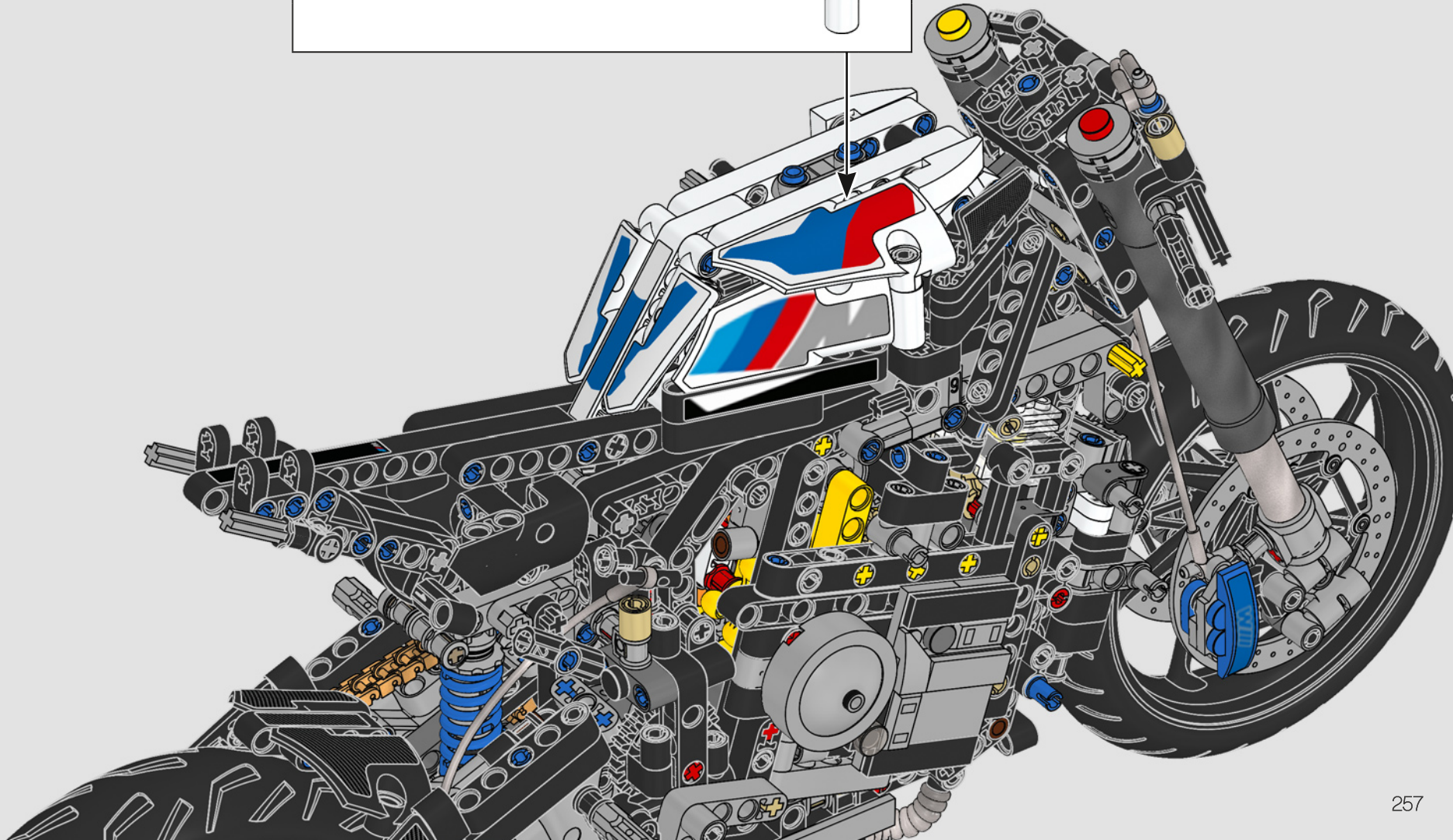
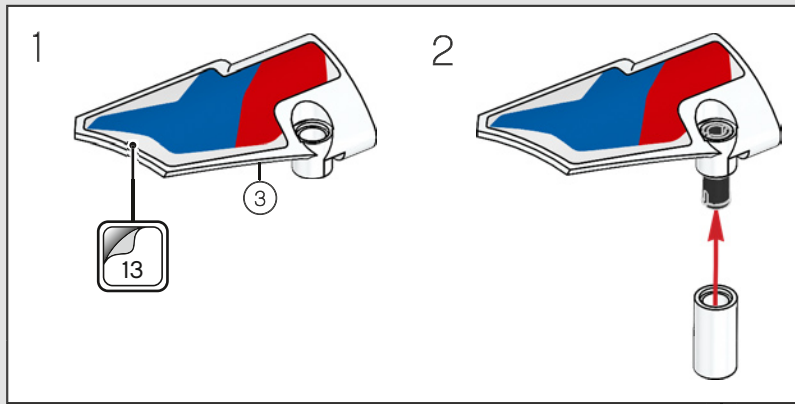

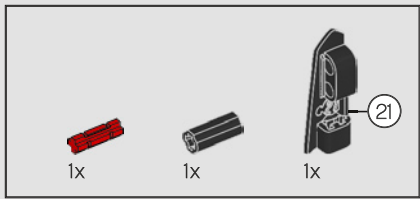

429

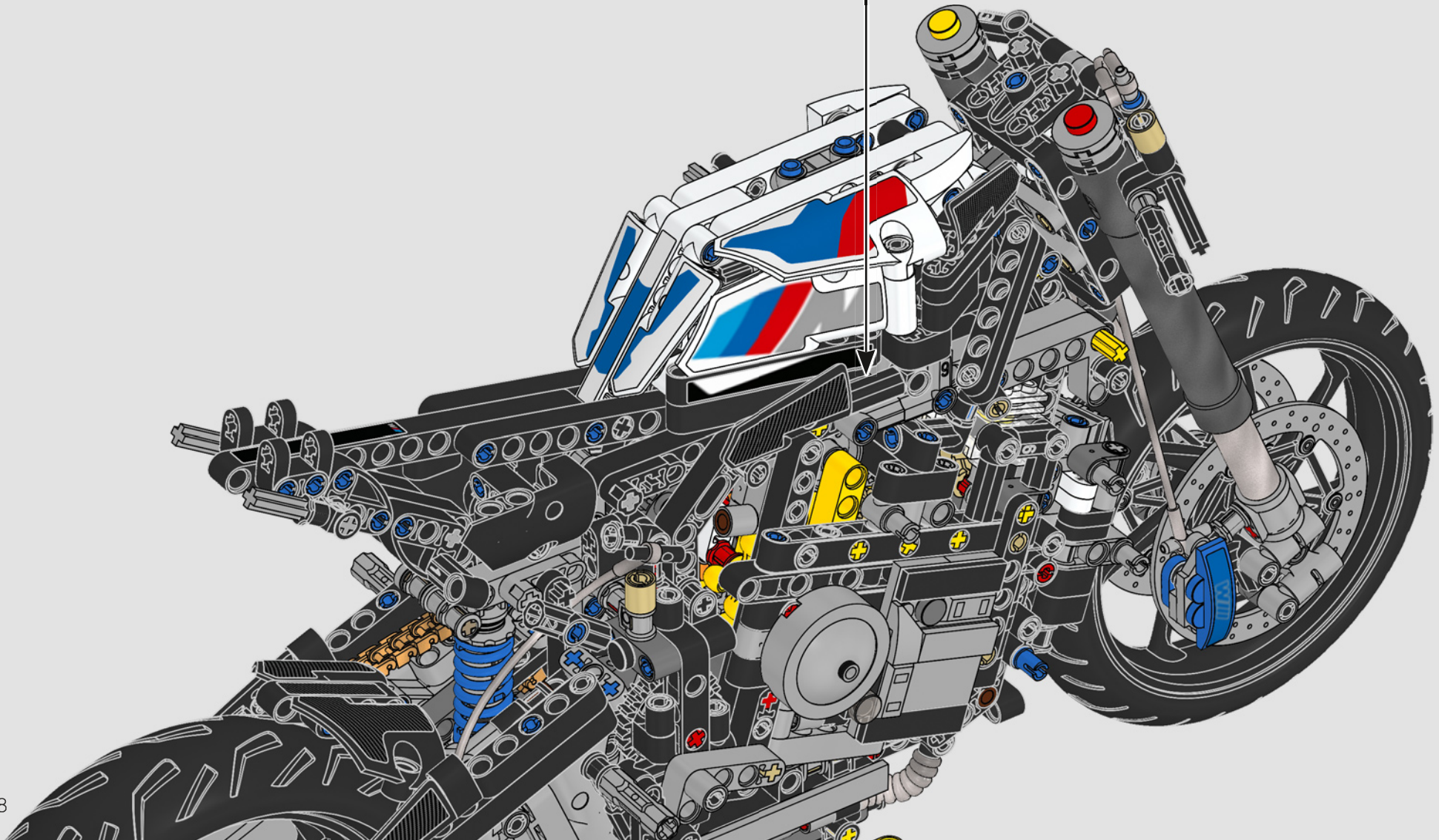
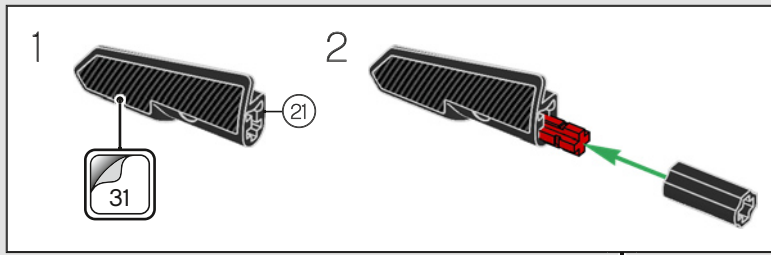

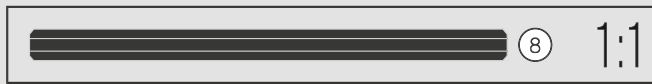
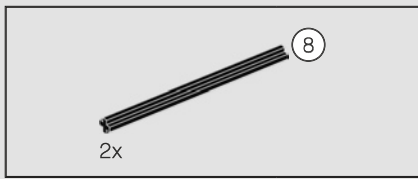

430

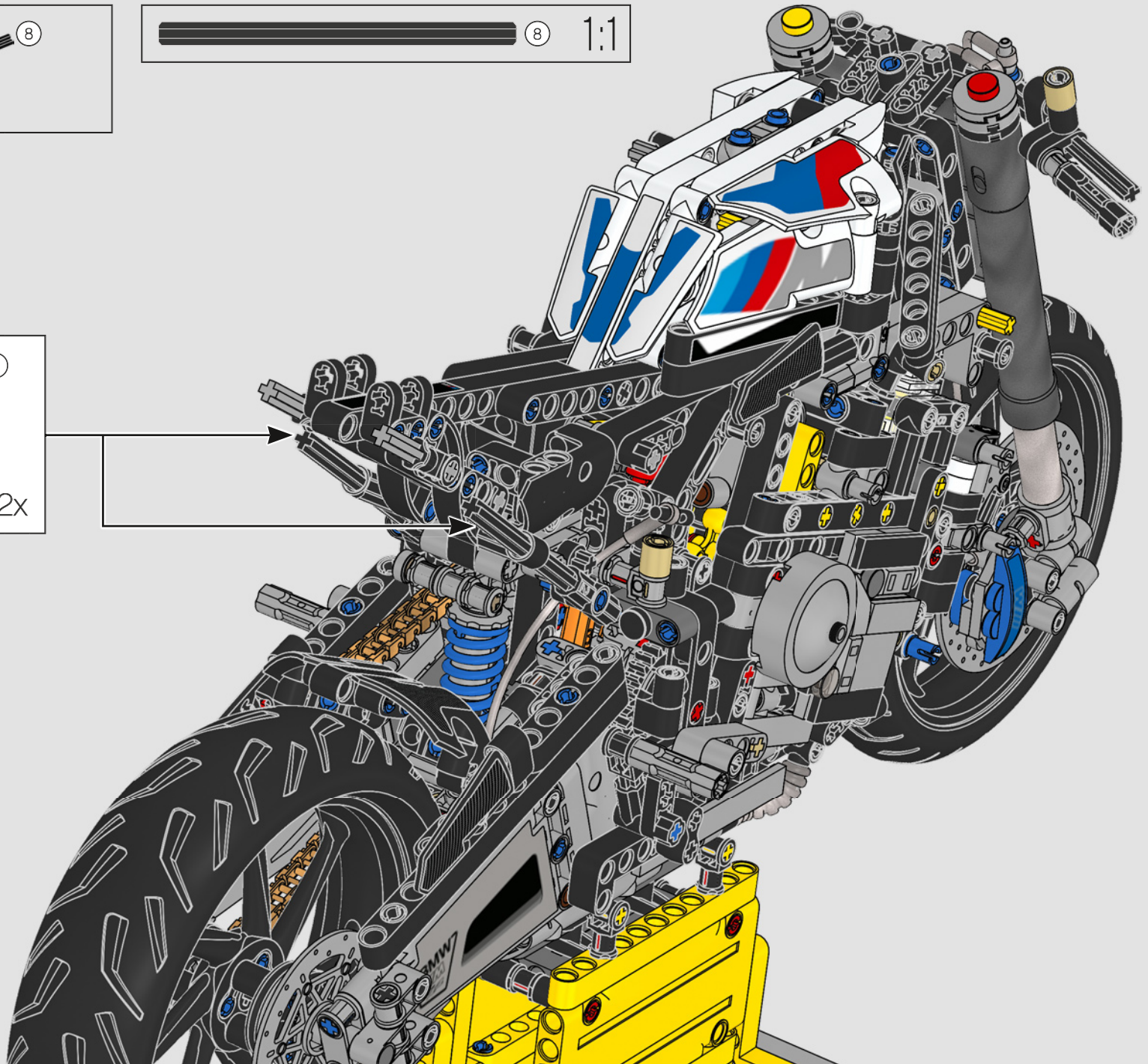
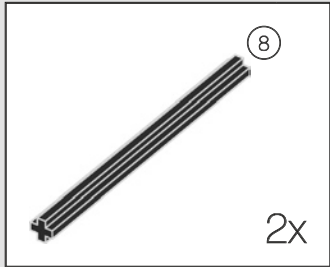

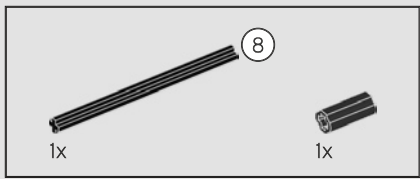

431

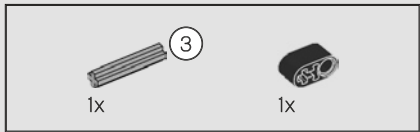
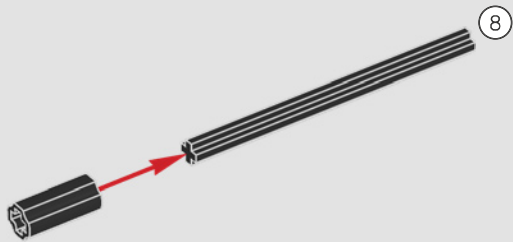

432

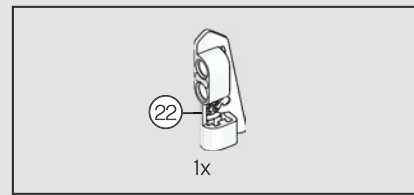
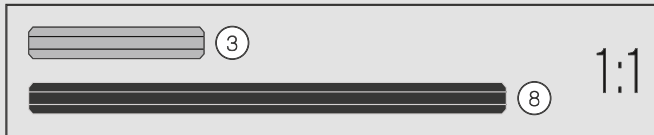
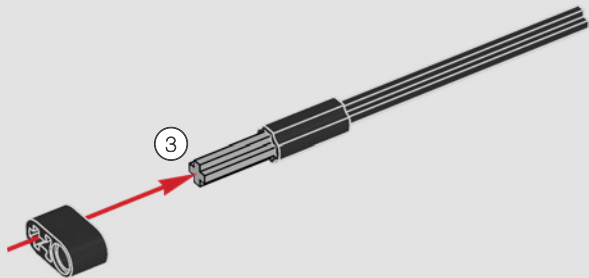

433

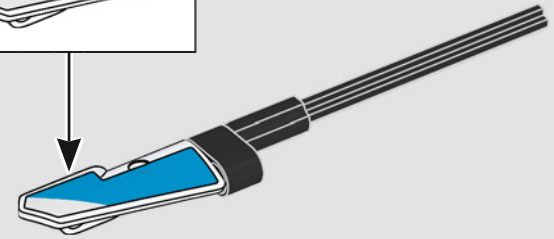
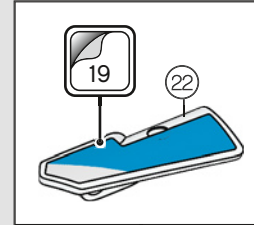

434

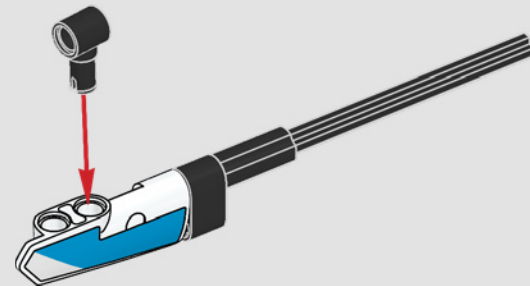

435

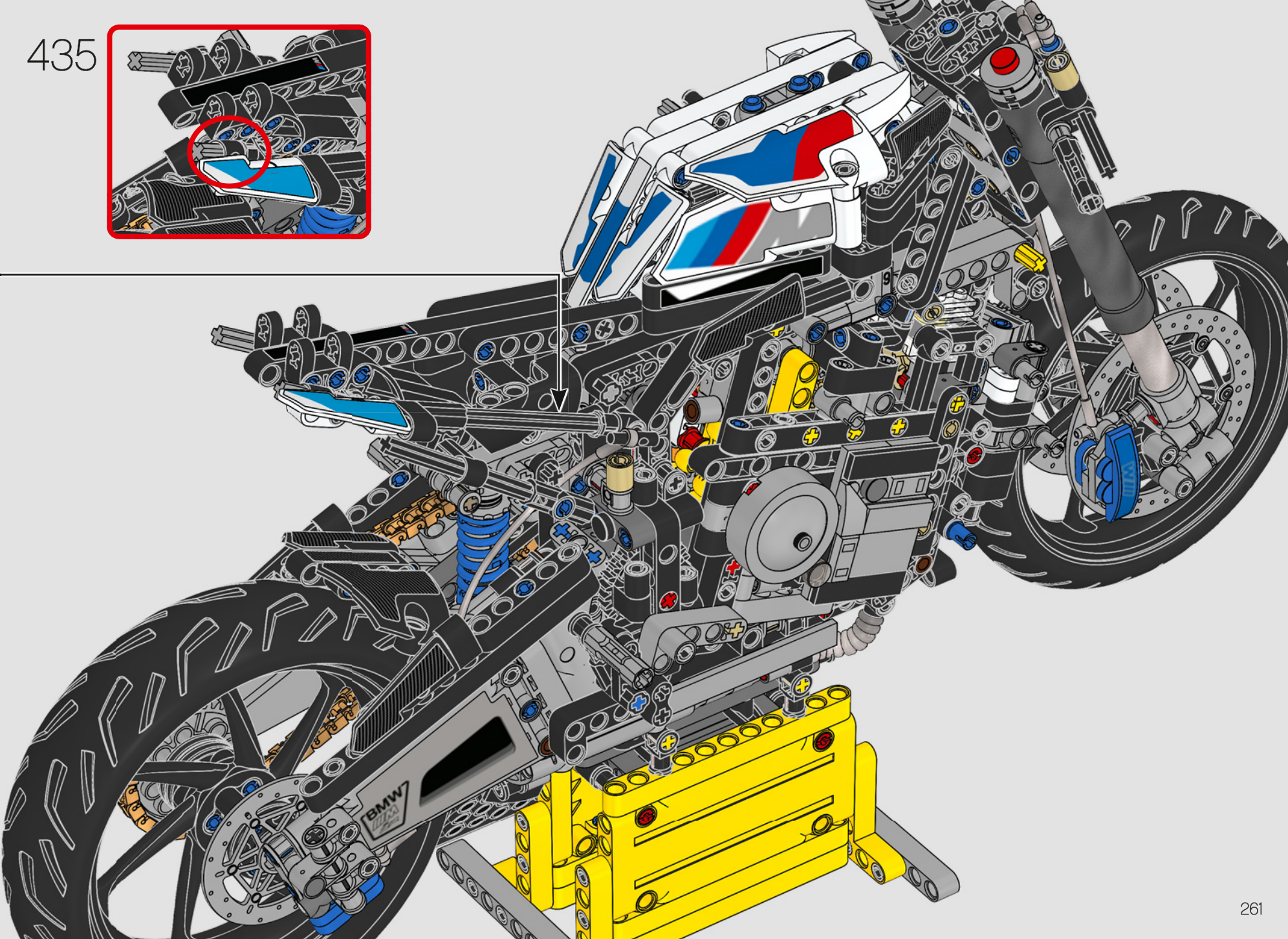
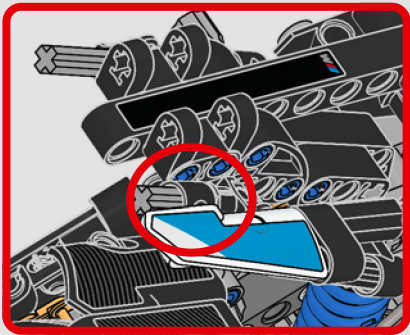

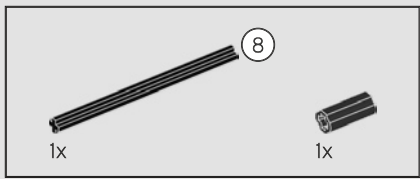

436

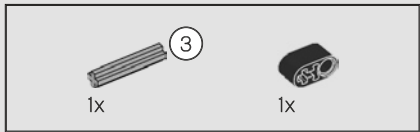
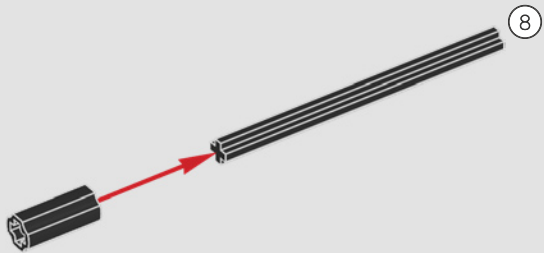

437

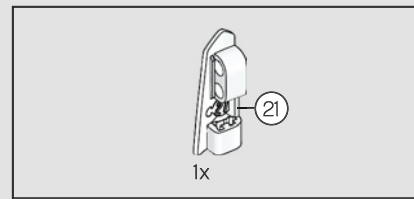
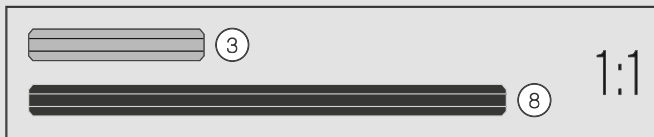
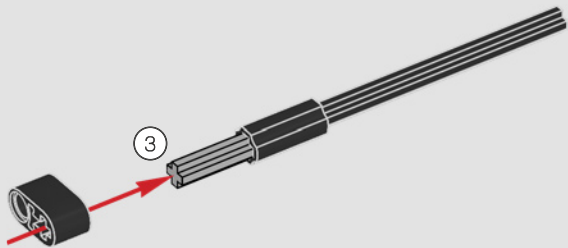

438

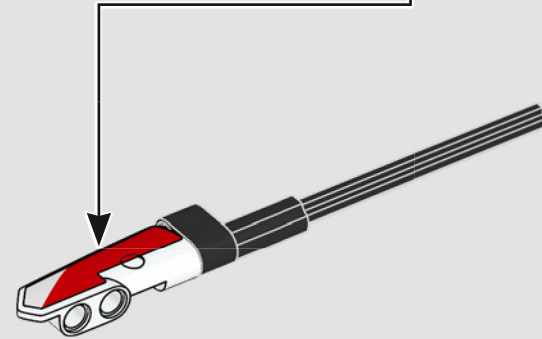
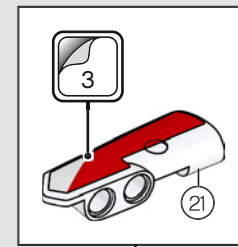

439

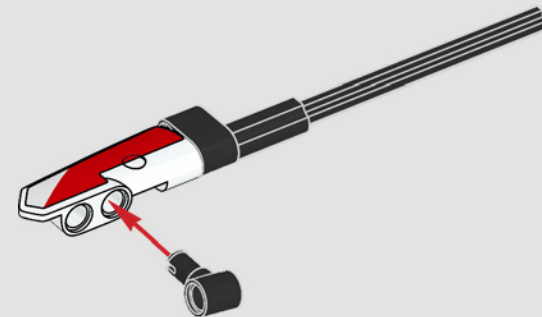

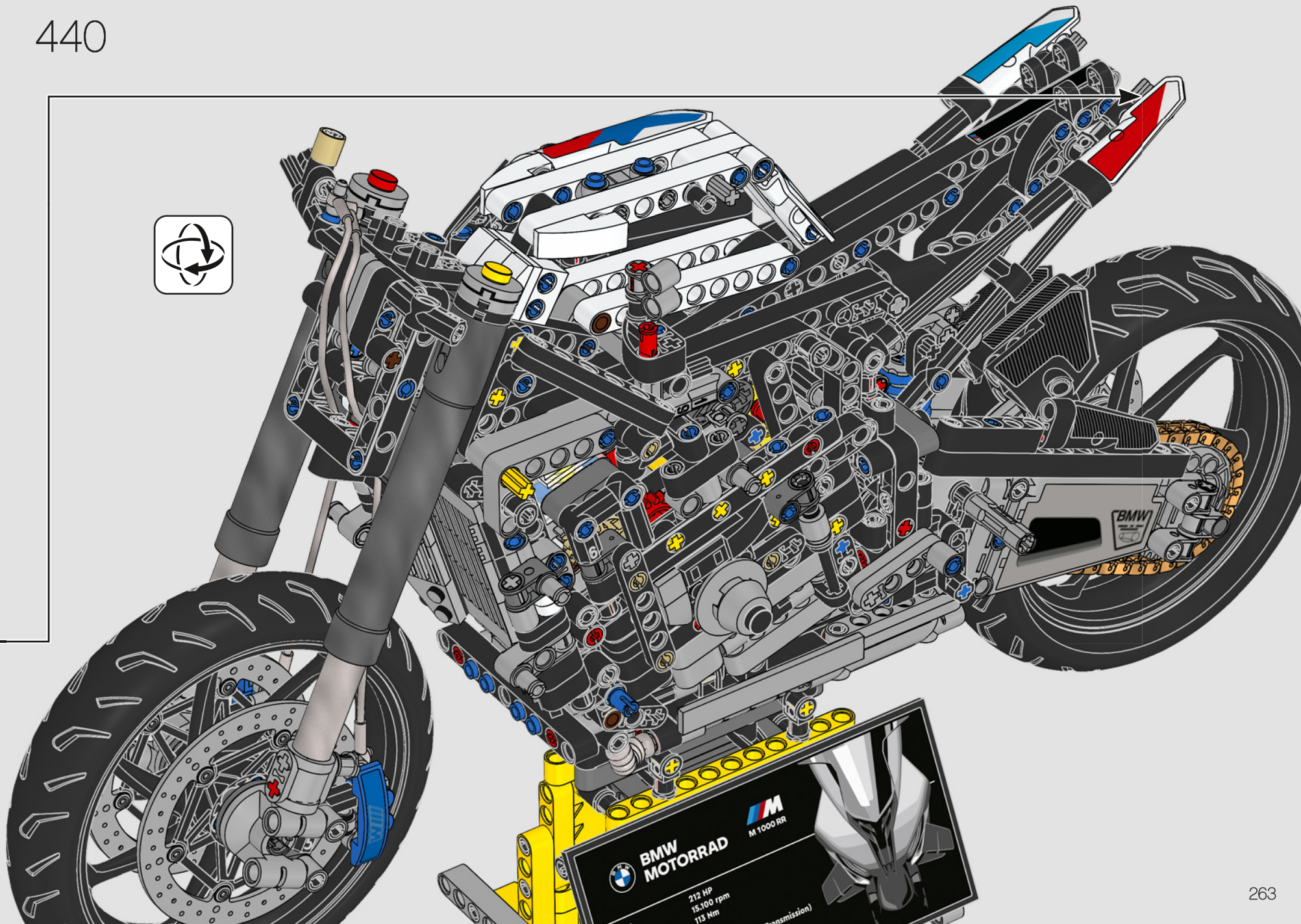

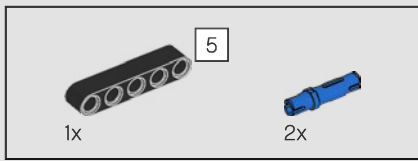

441

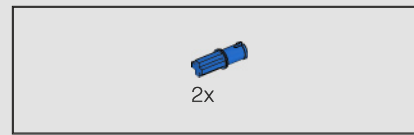
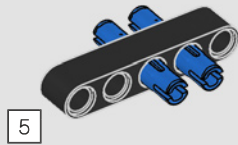

443

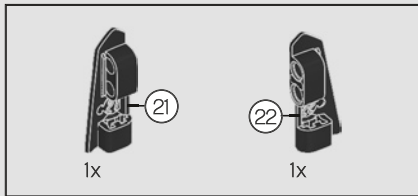
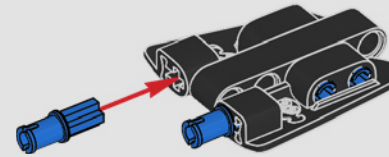

442

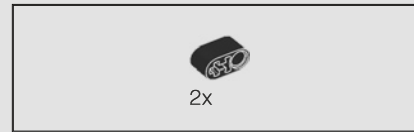
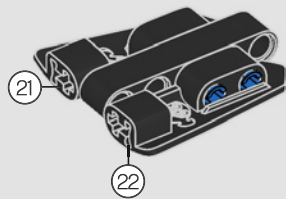

444

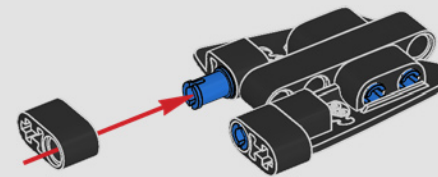

445

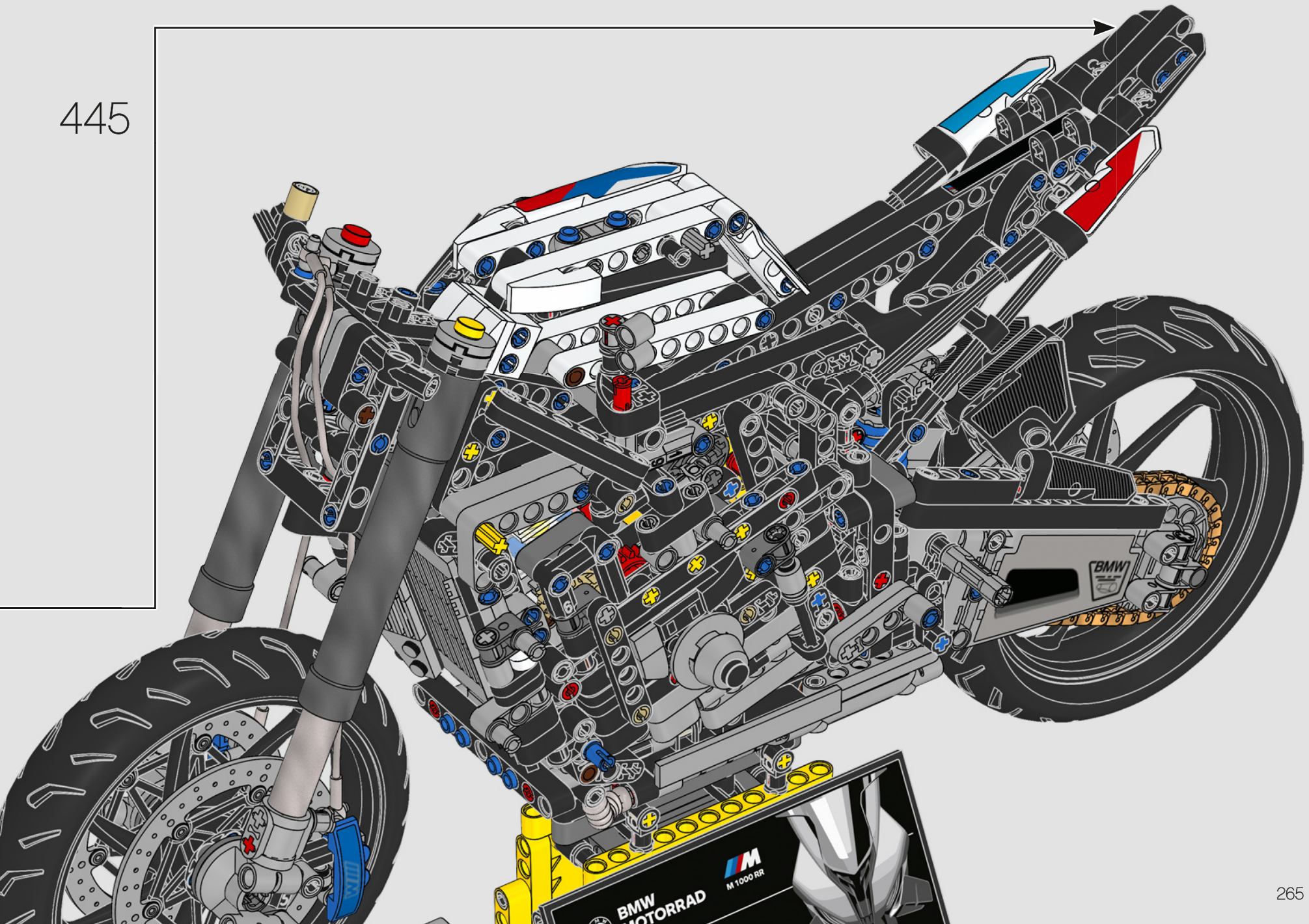

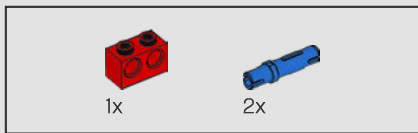

446

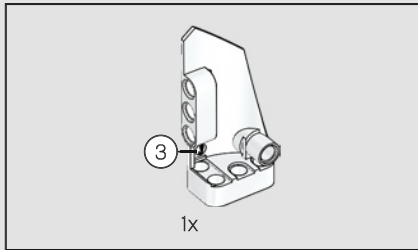
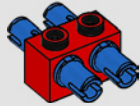

447

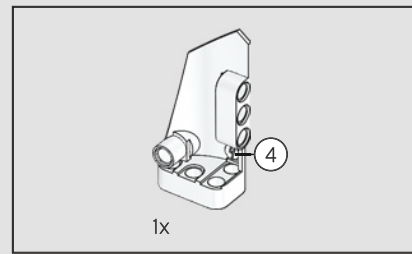
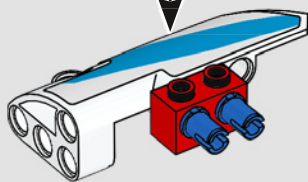
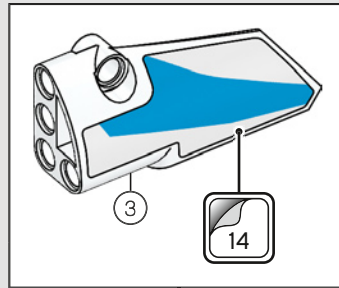

448

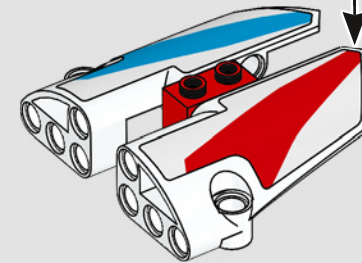
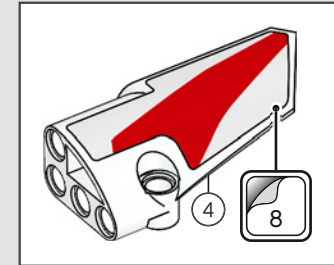

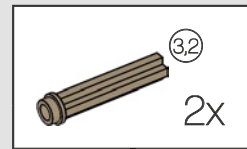
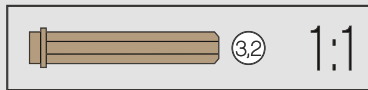
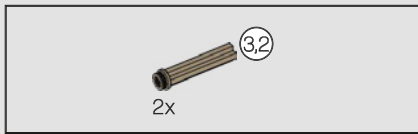

449

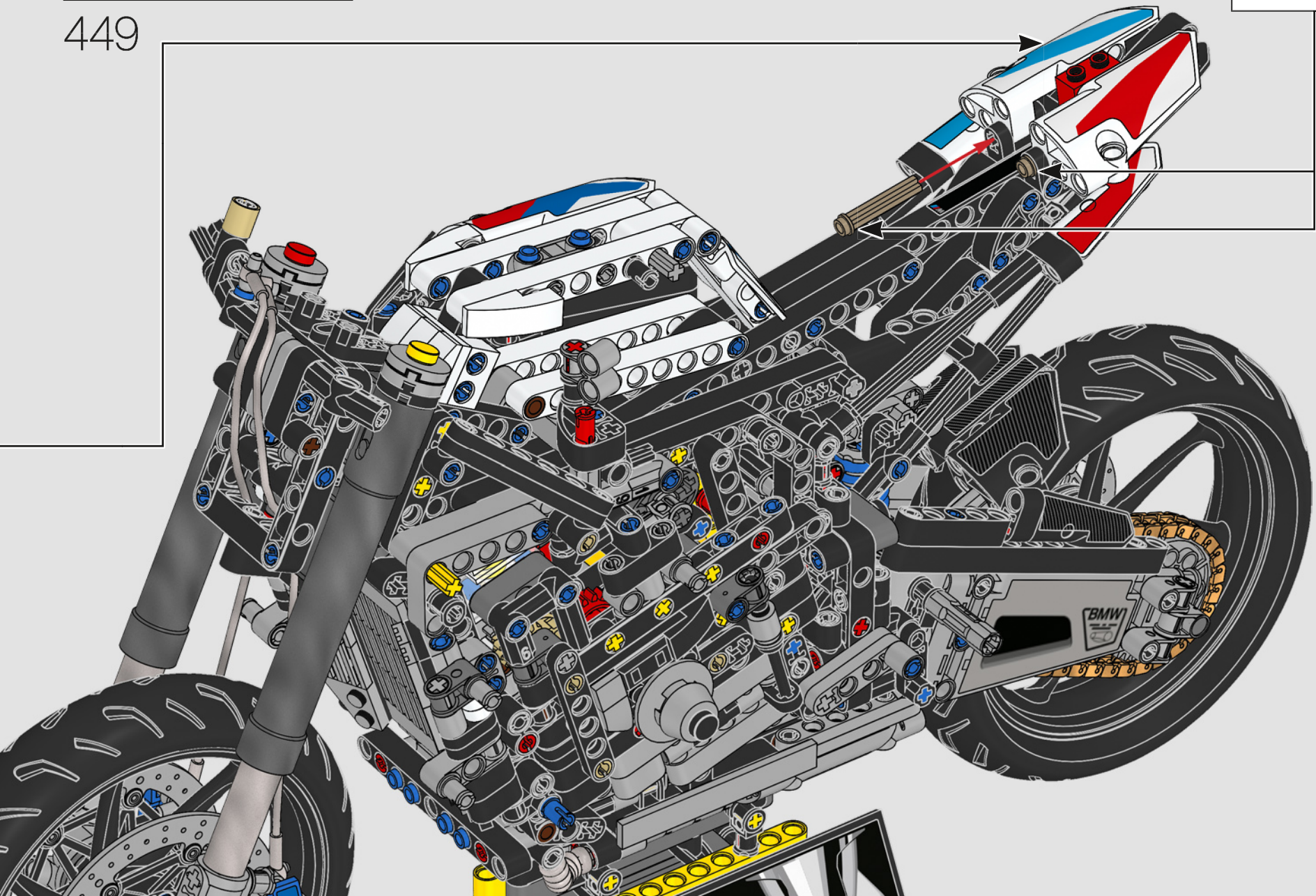

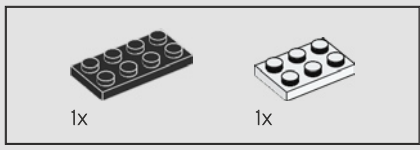

450

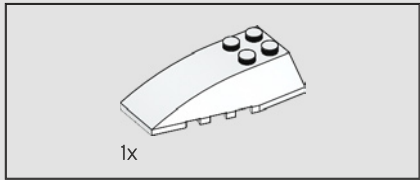
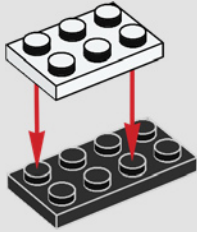

451



452

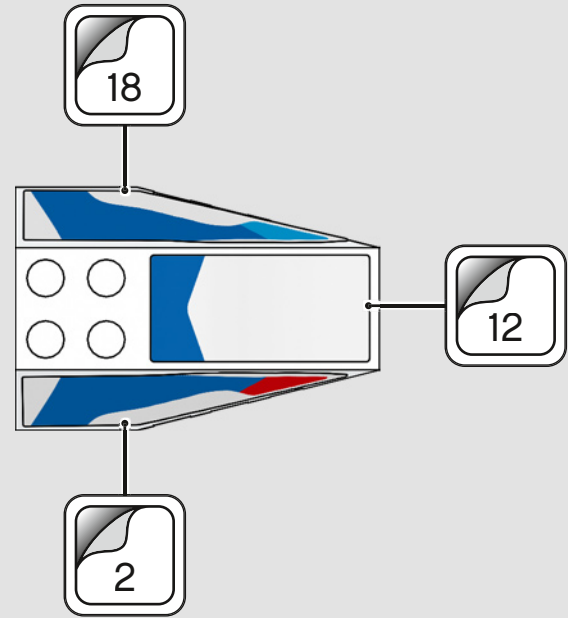

453

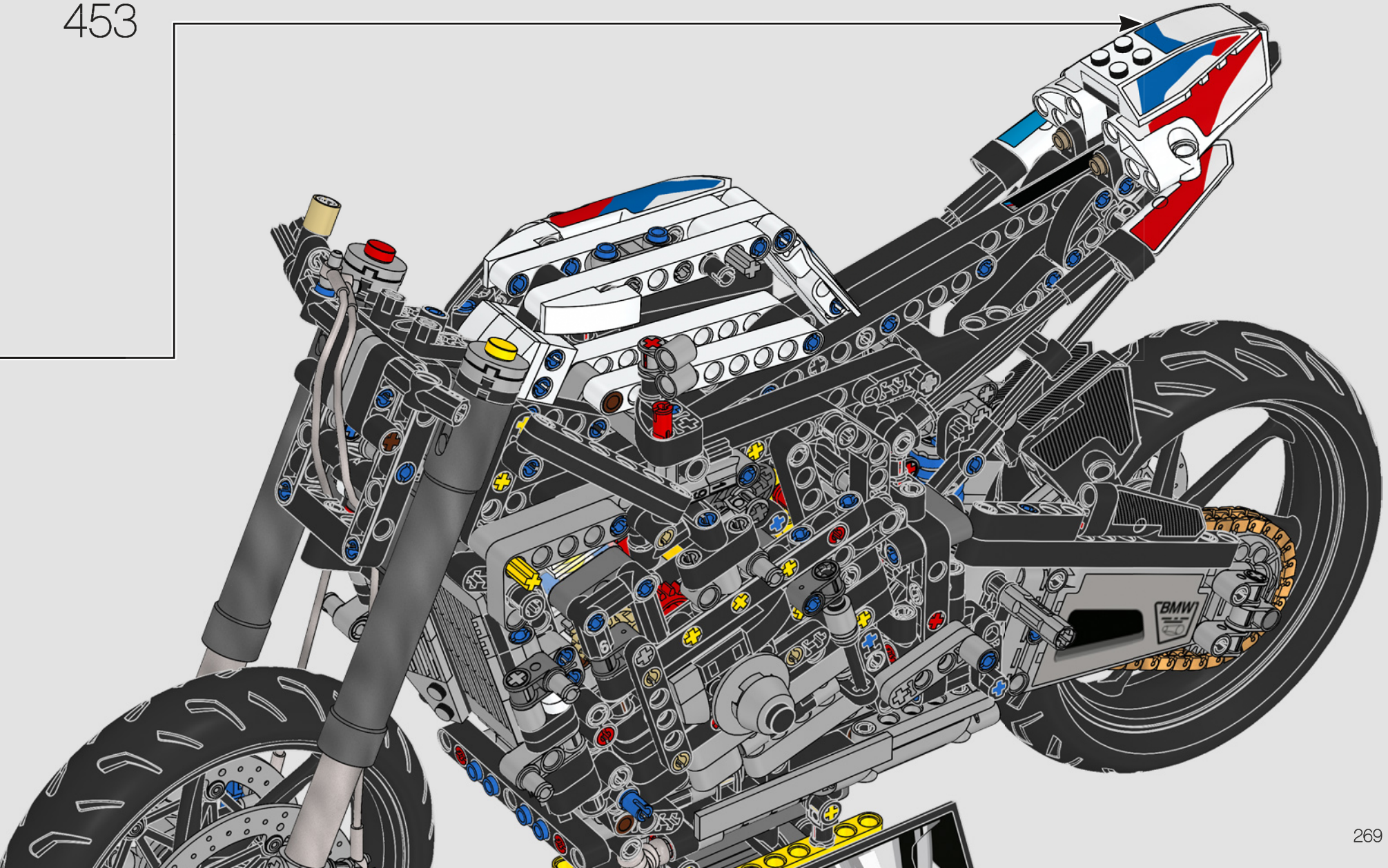

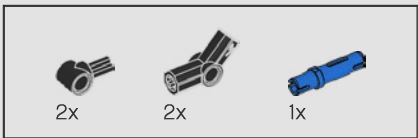

454

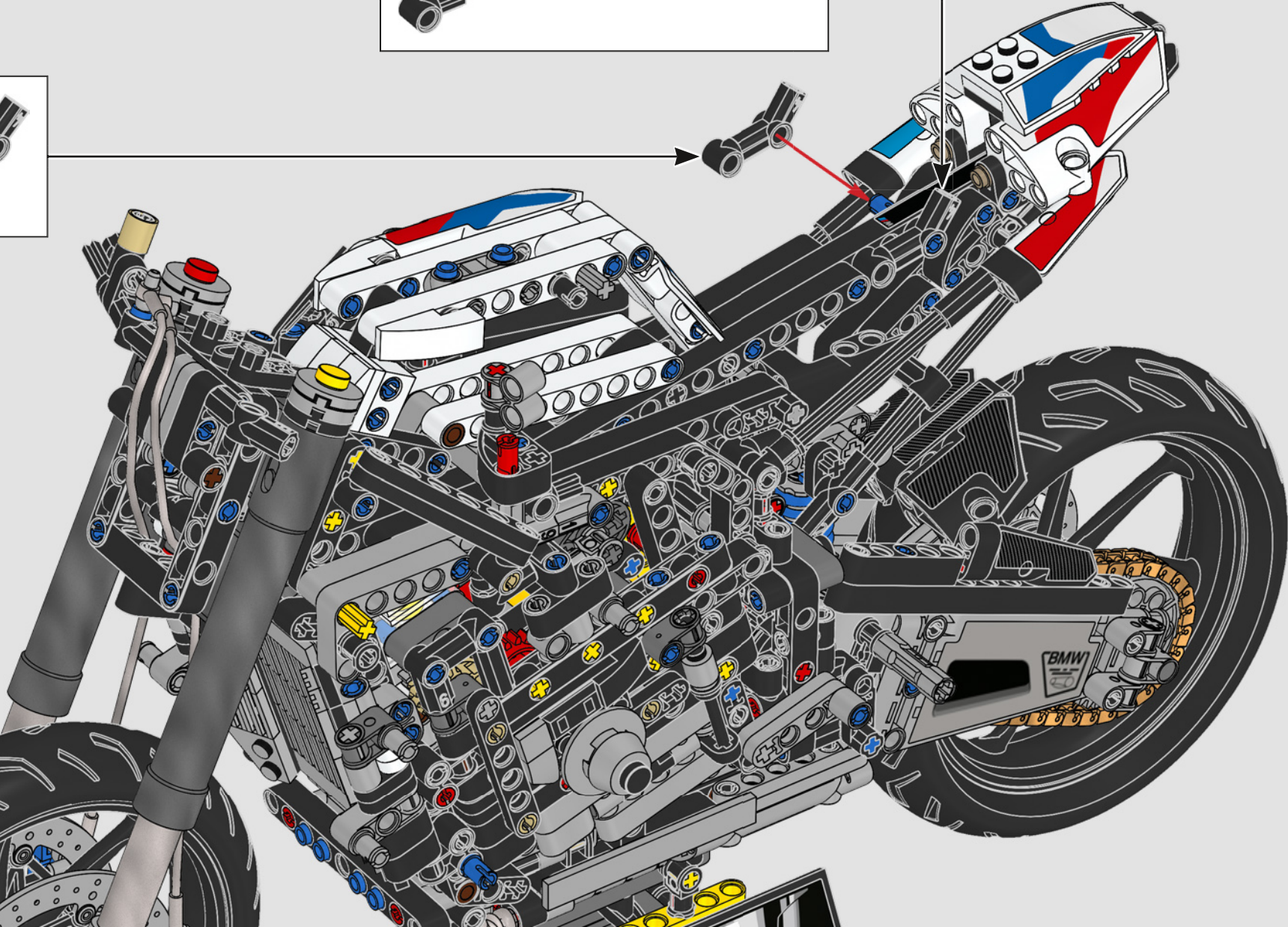
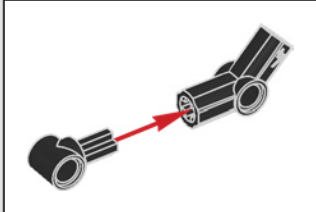
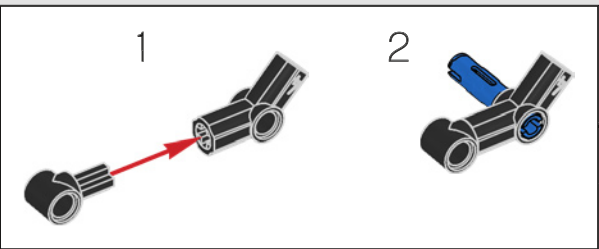

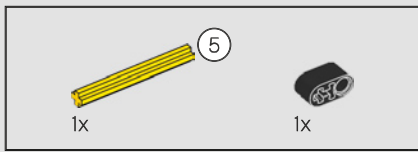

455



456

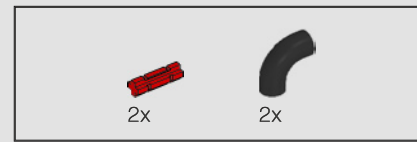
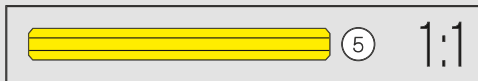
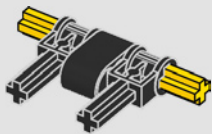

457

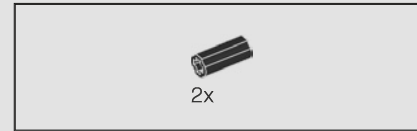
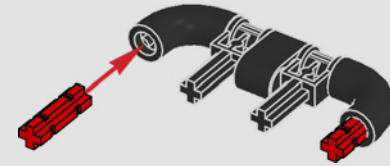

458

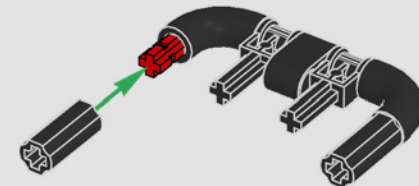

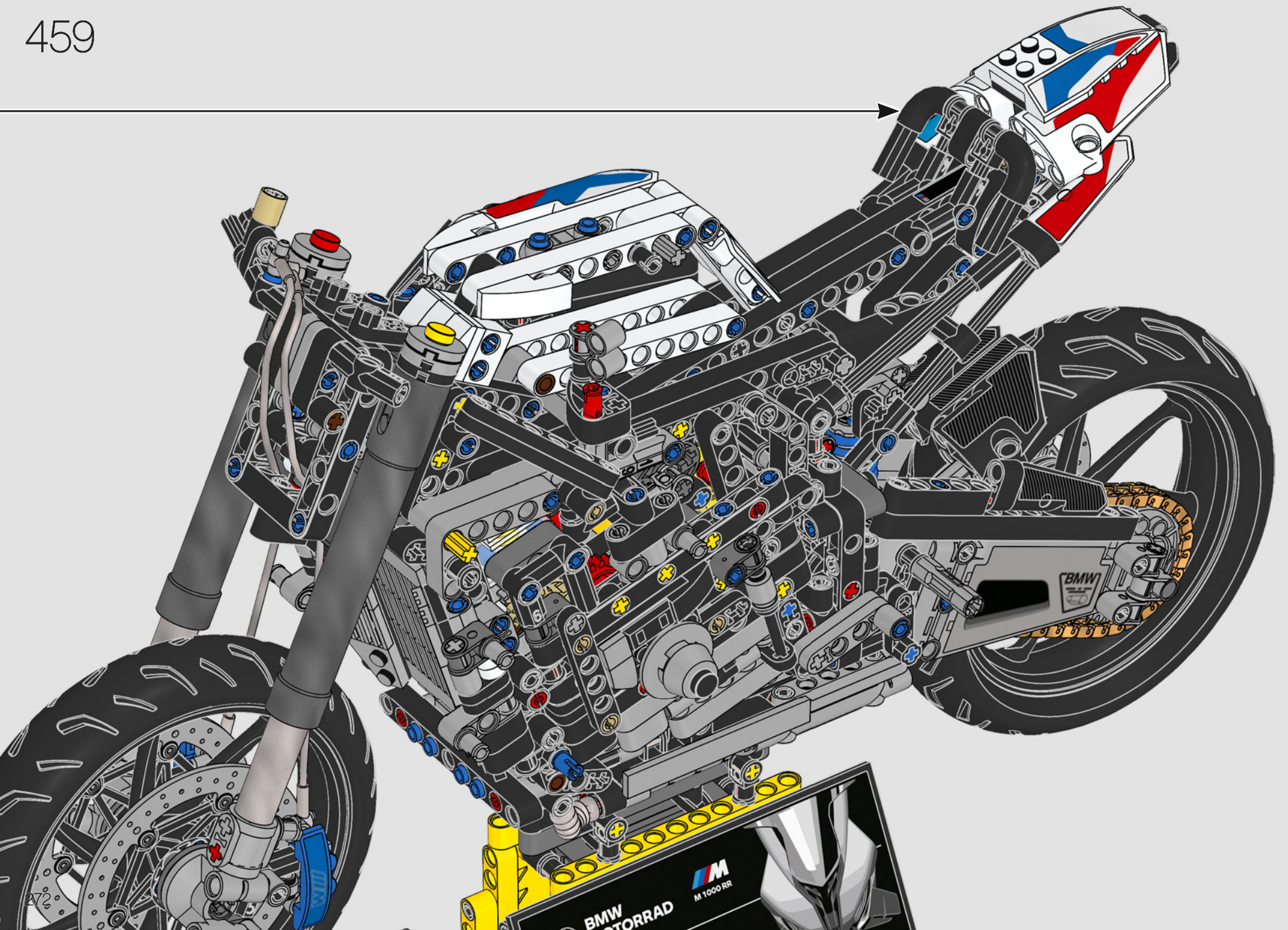

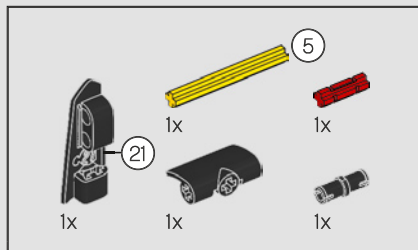

460

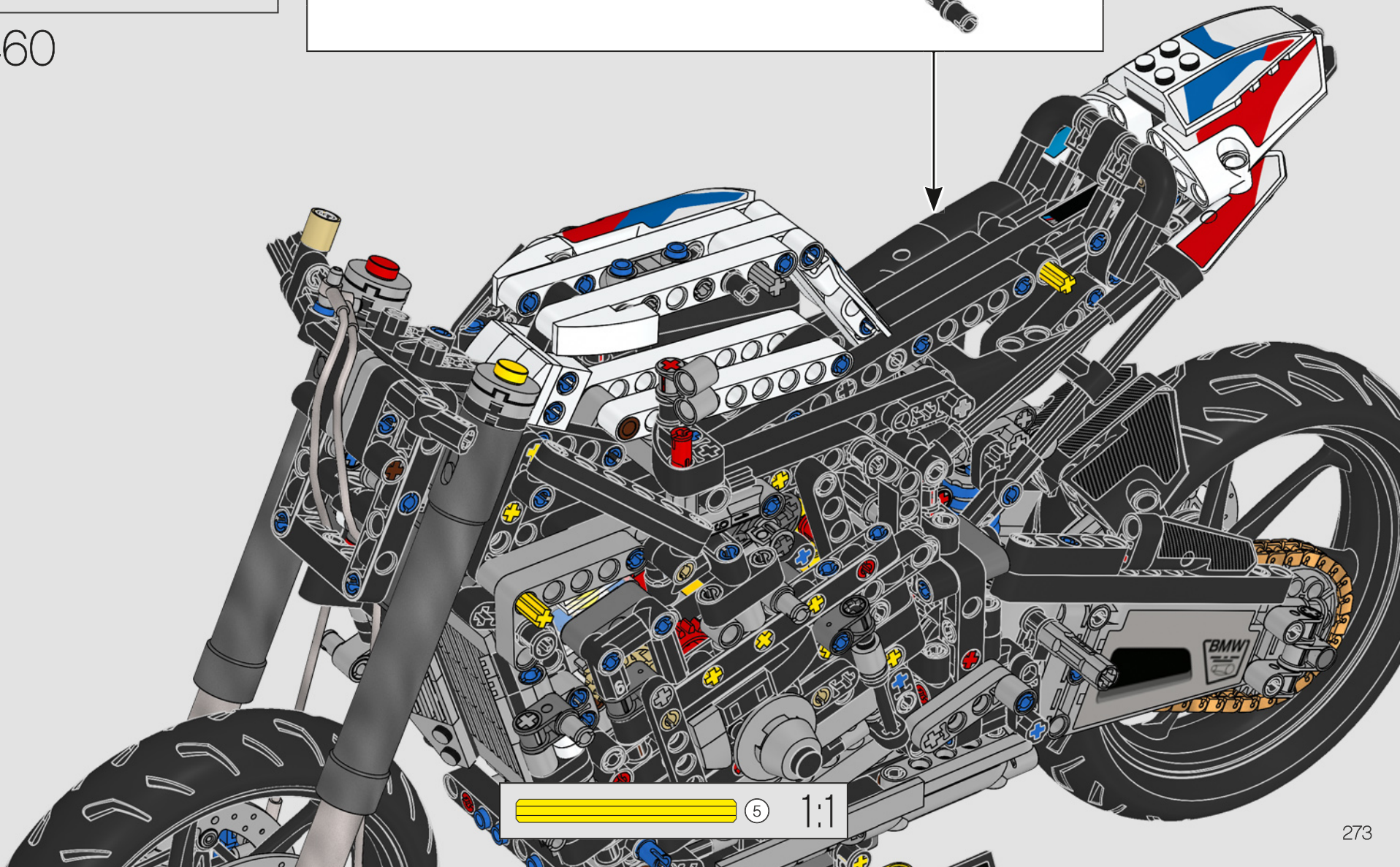
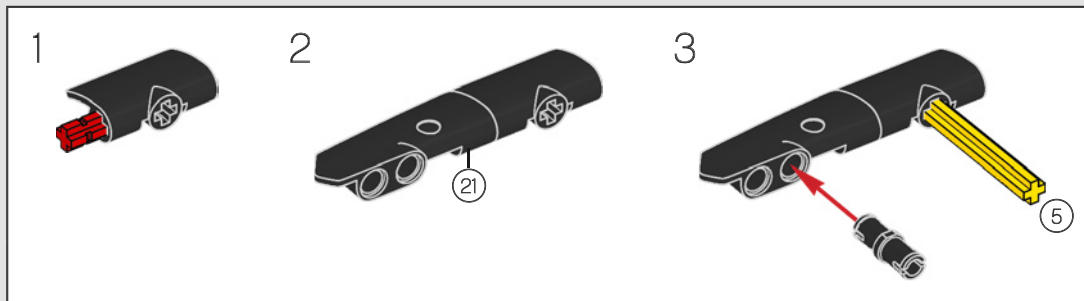

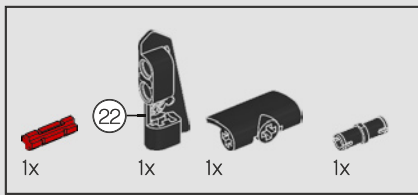

461

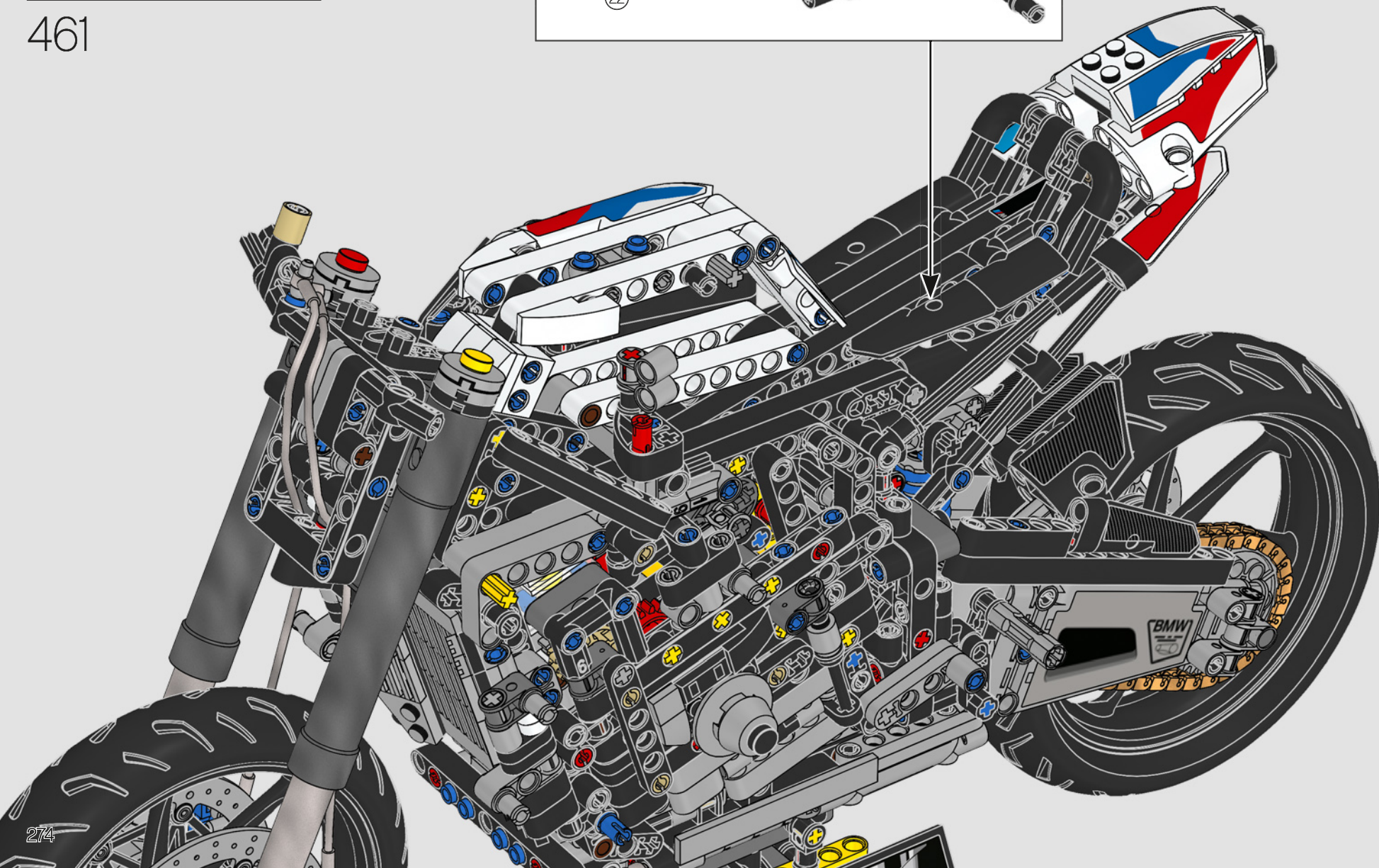
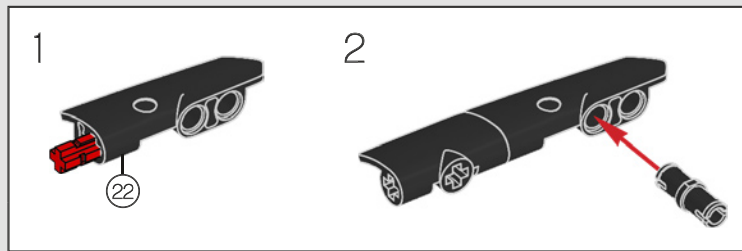

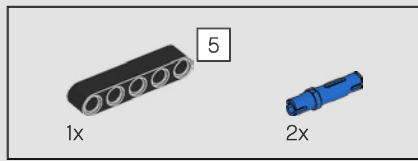

462

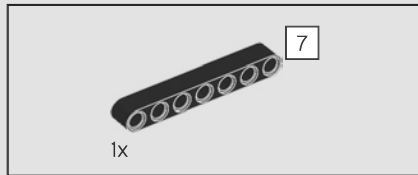
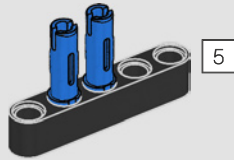

463

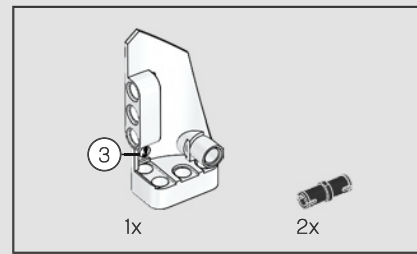
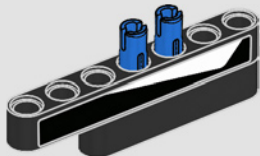
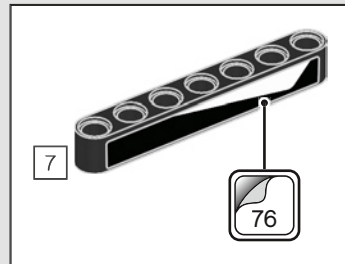

464

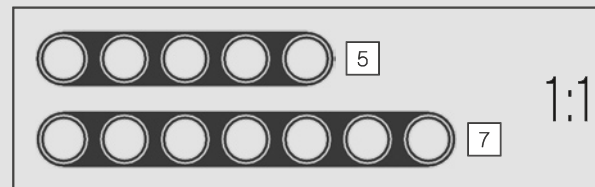
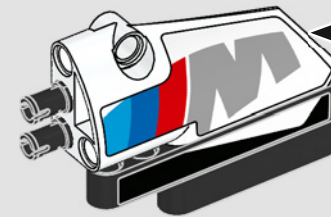
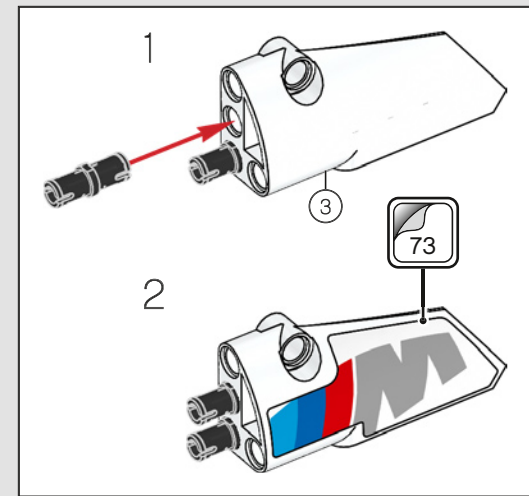

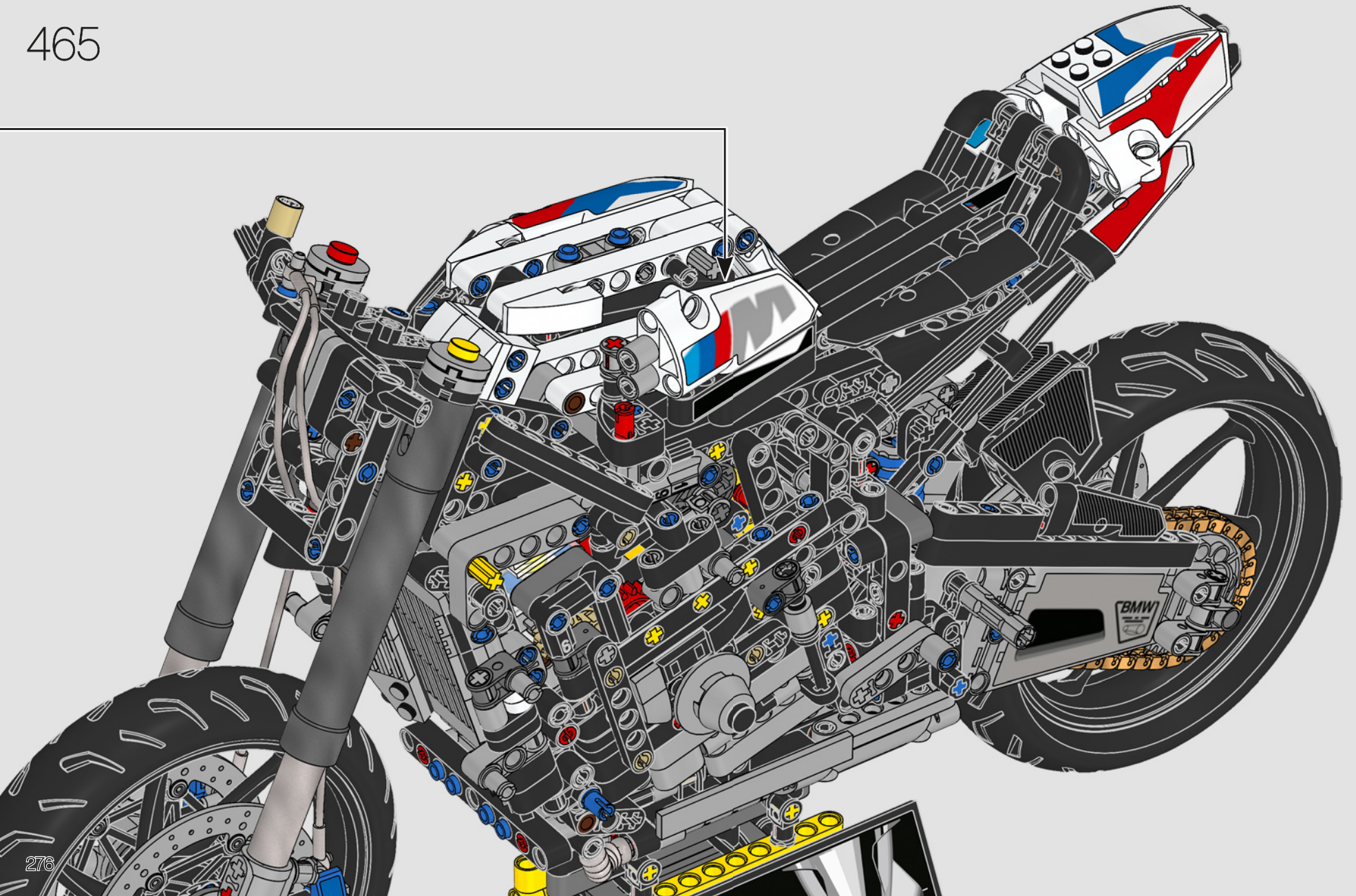



466

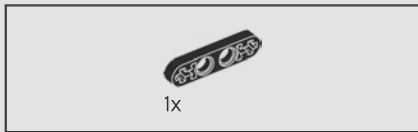
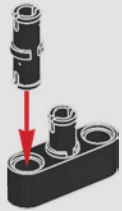

467

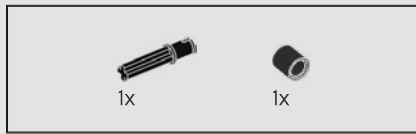
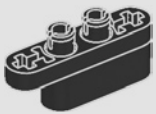

468

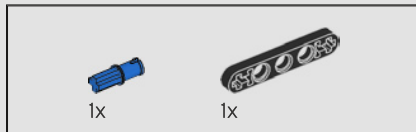
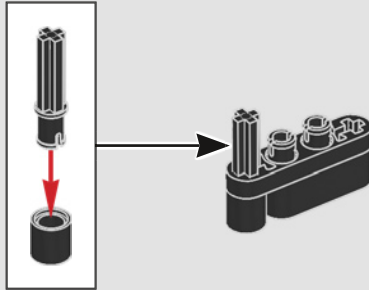

469

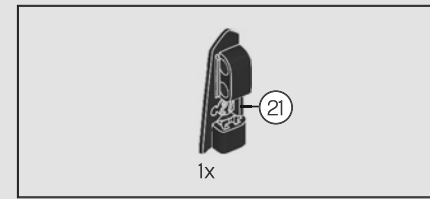
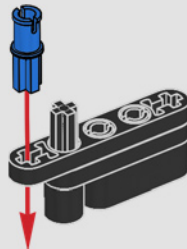

470

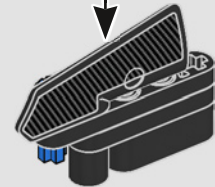
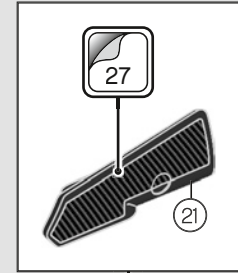

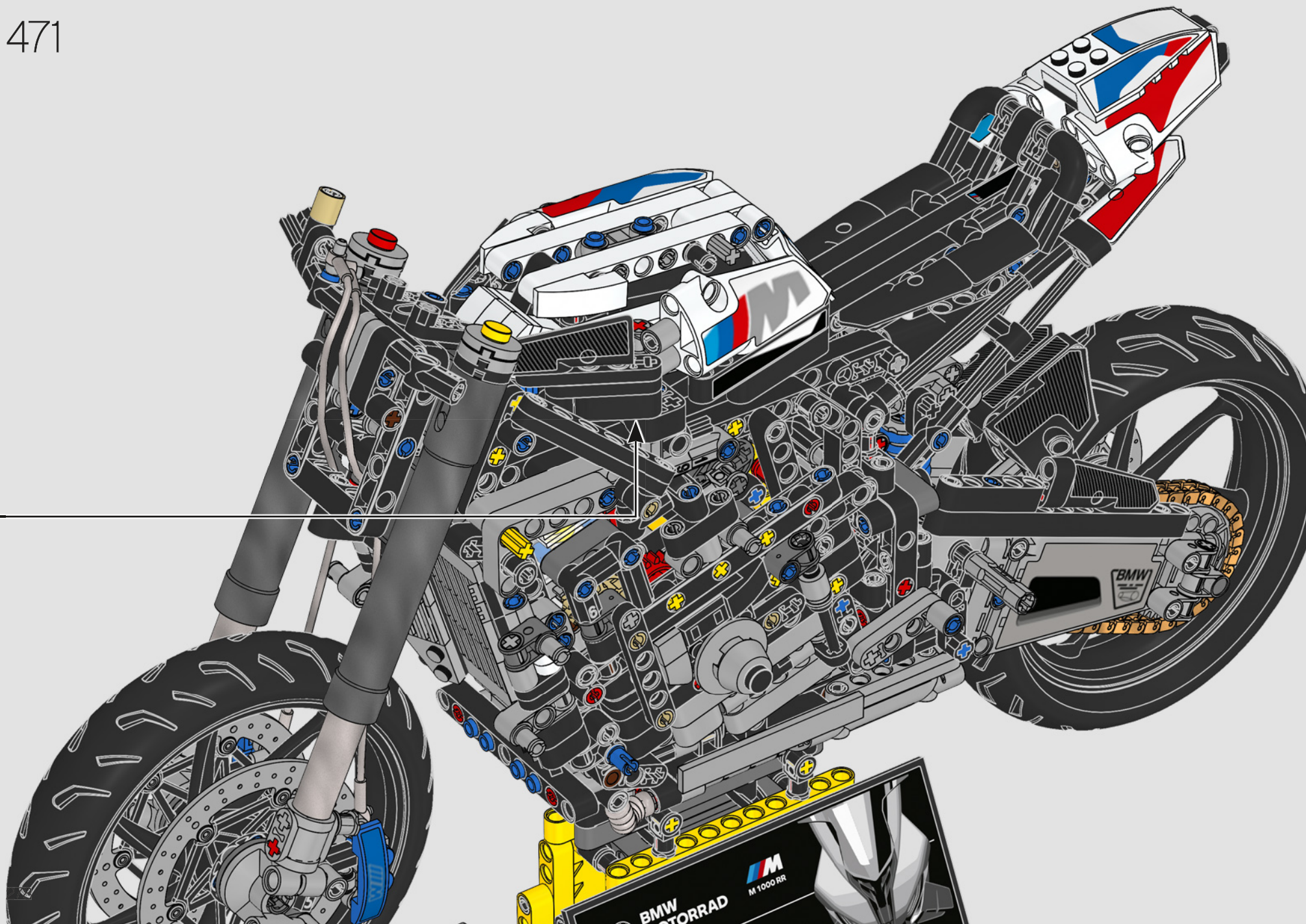

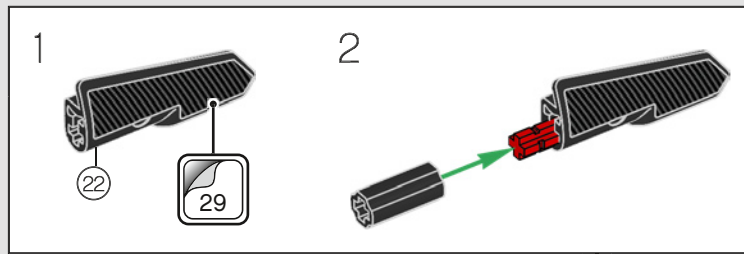
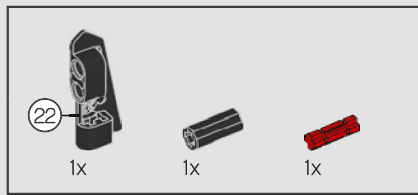

472

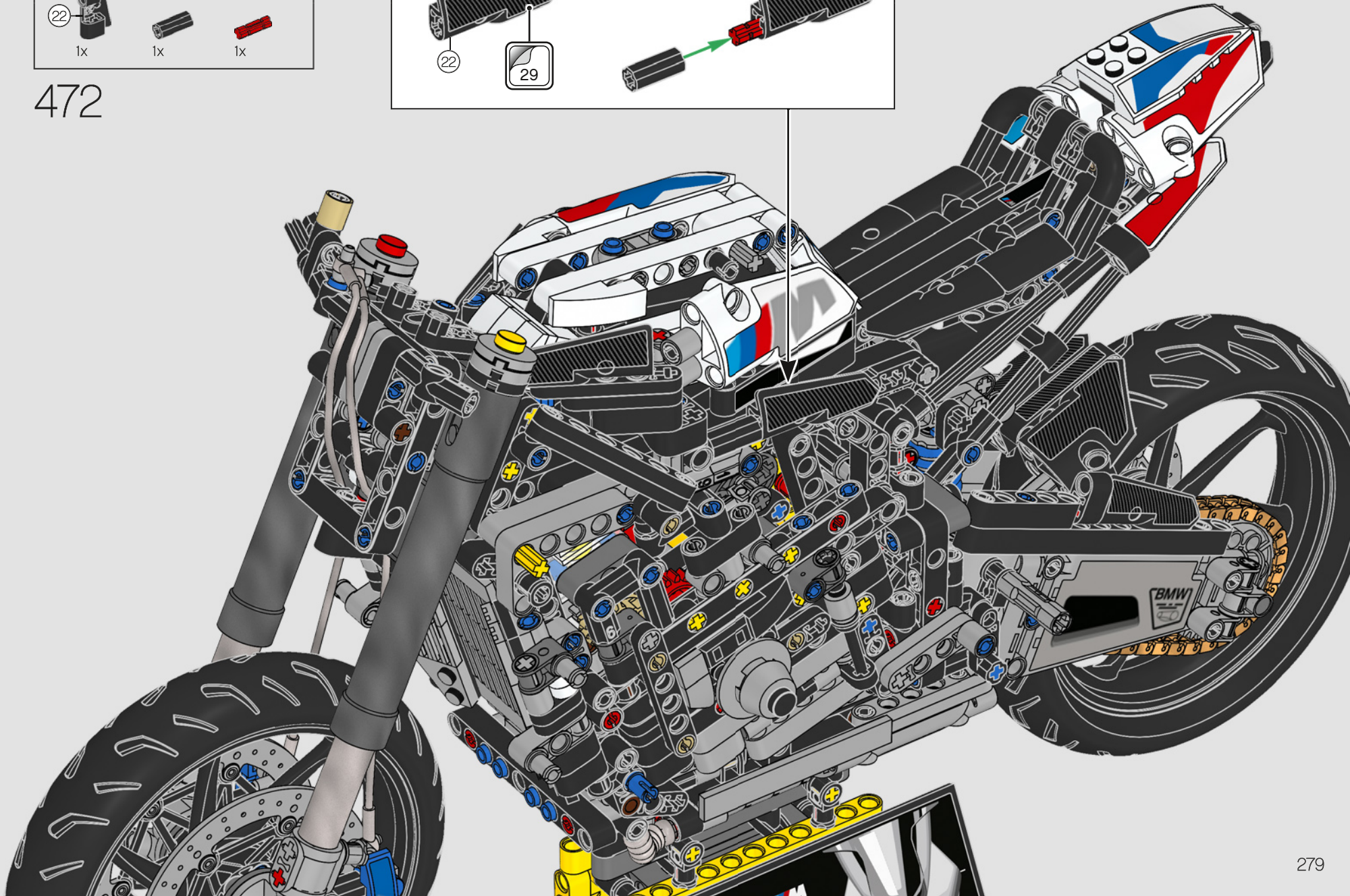

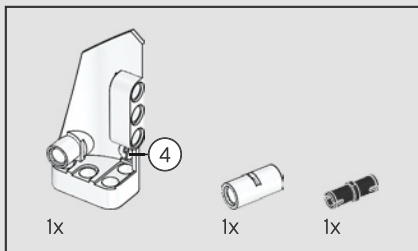

473

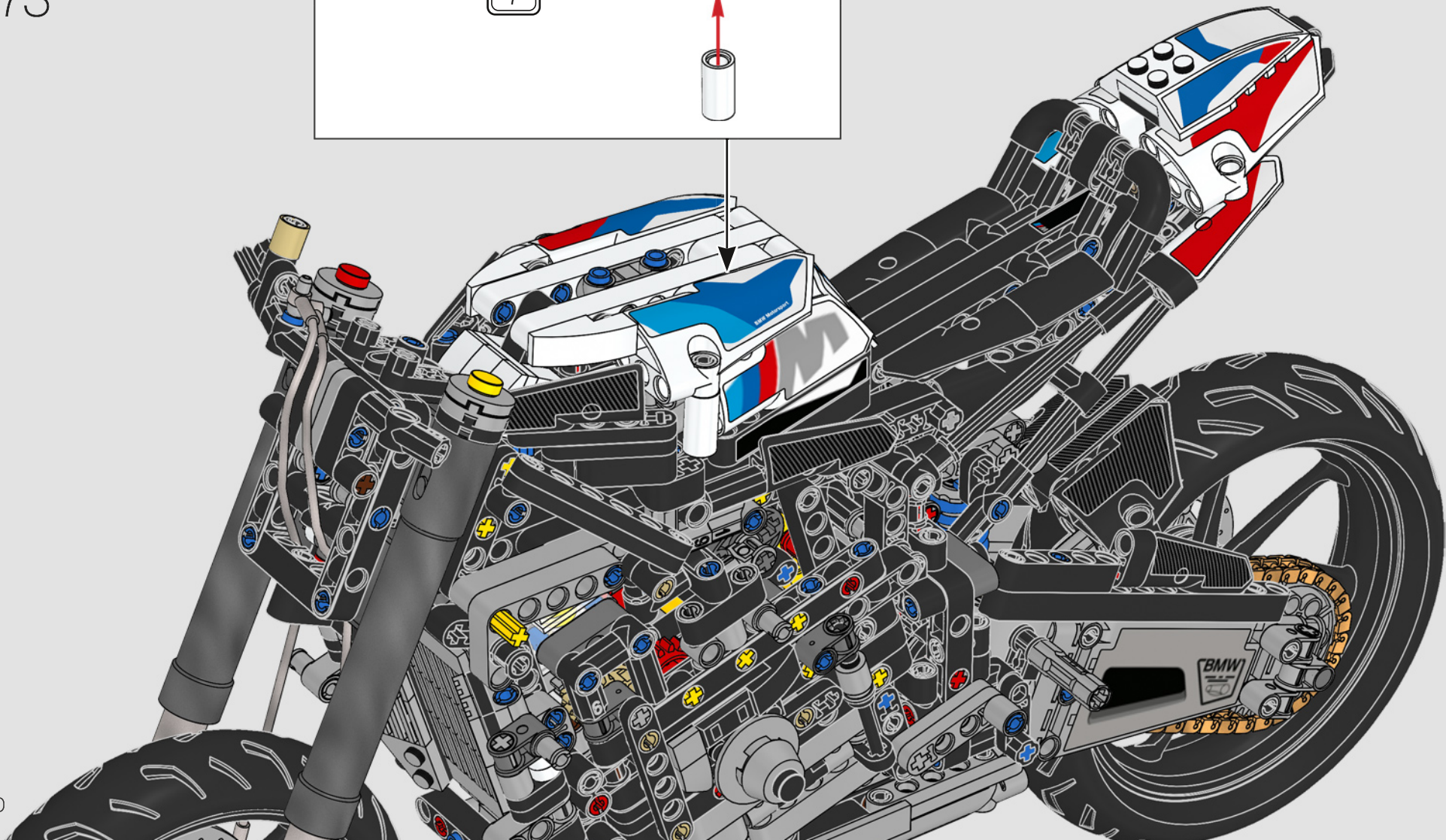
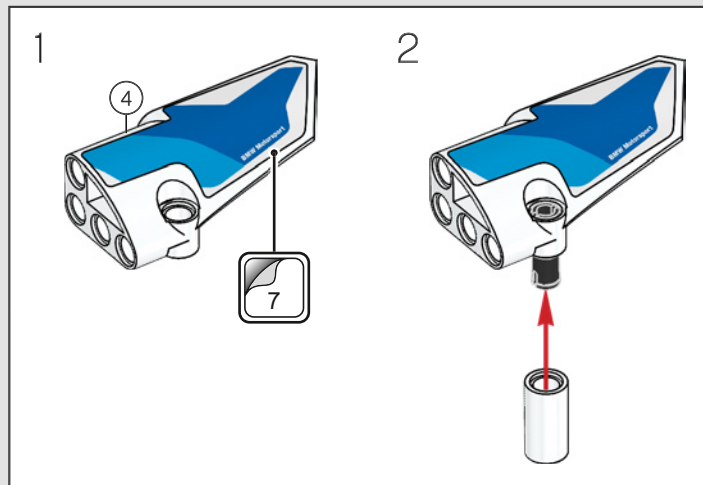

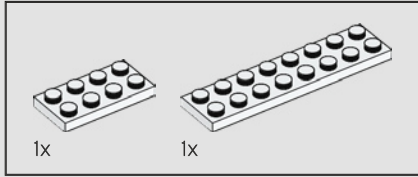
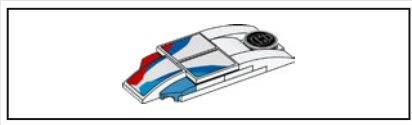

474

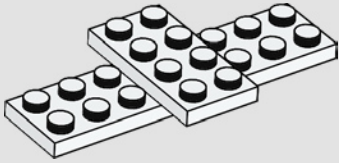

475

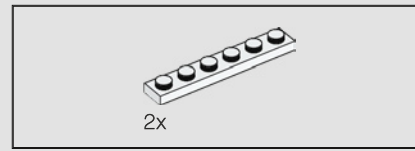
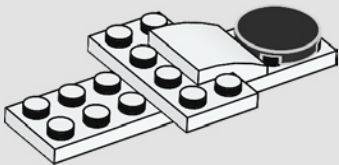

476

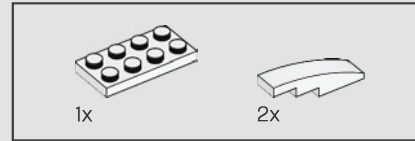
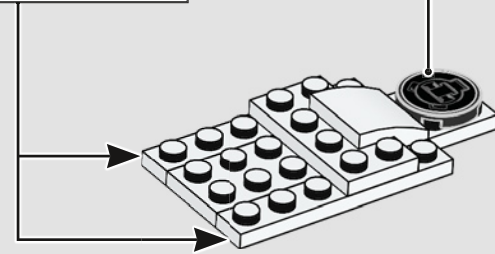
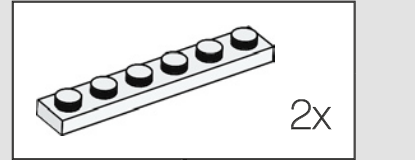

477

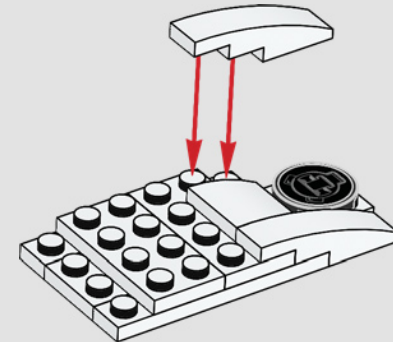

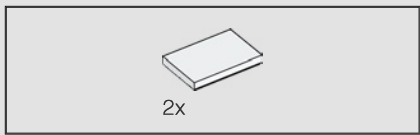

478

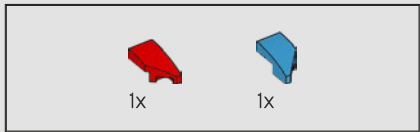
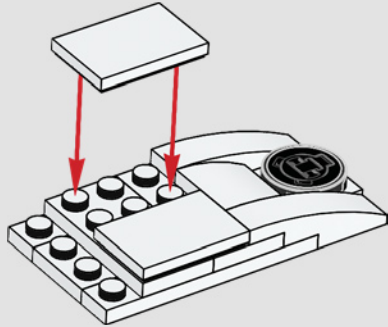

479

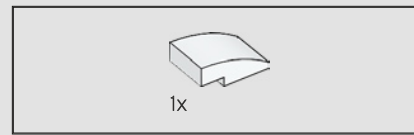
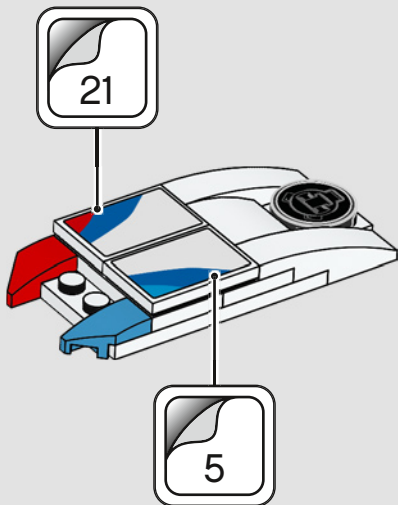

480

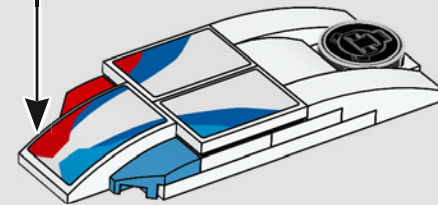
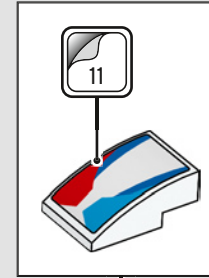

481

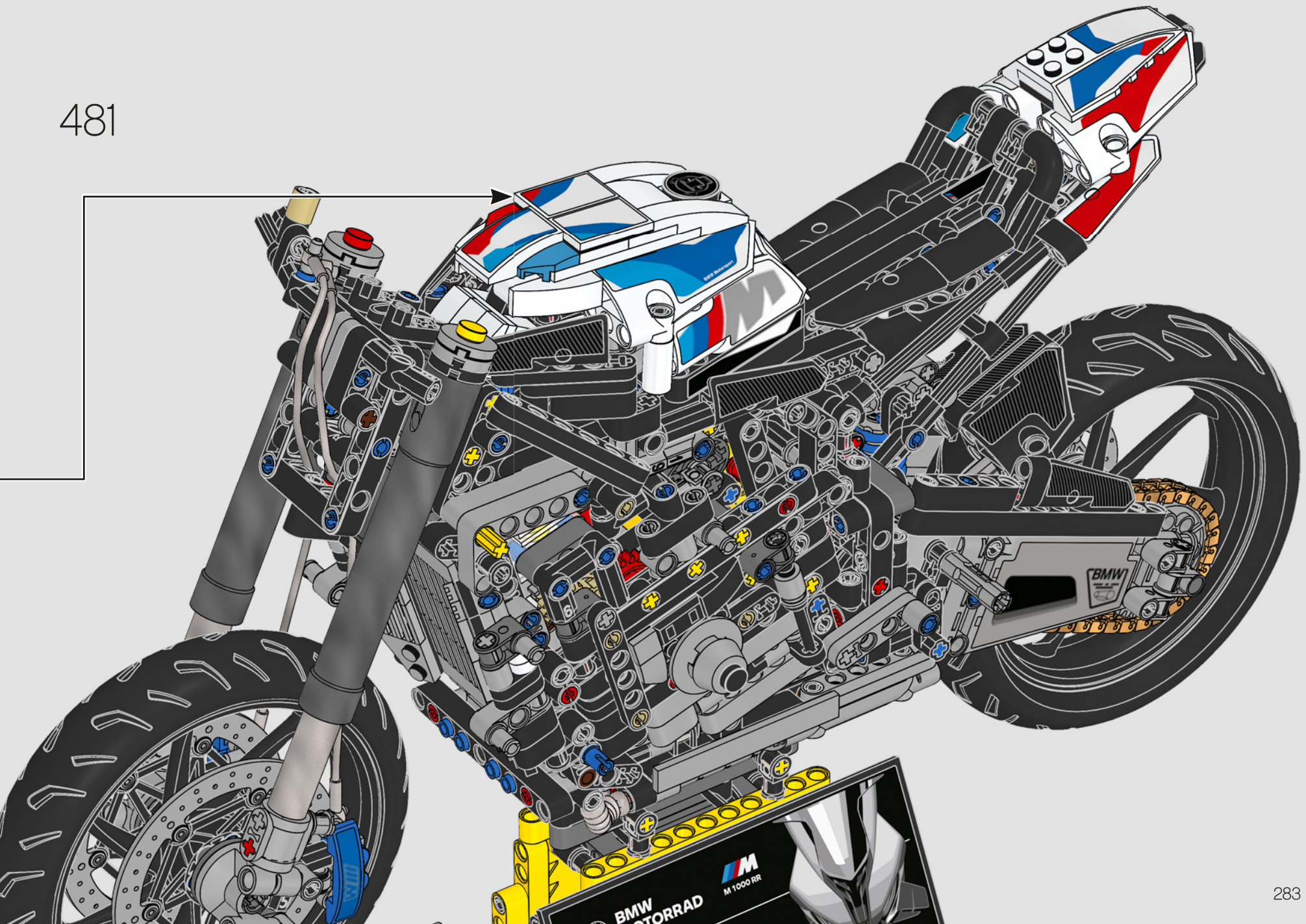

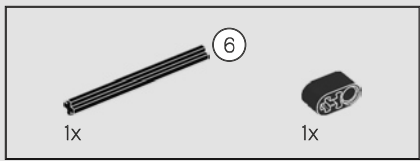

482

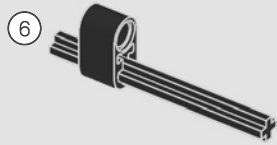

483

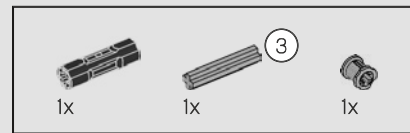
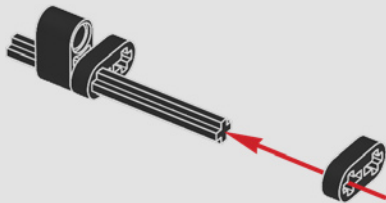

484

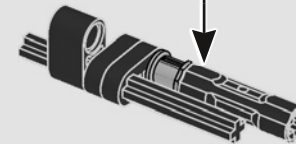
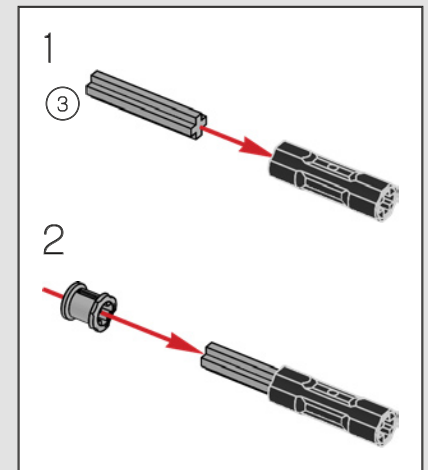

485

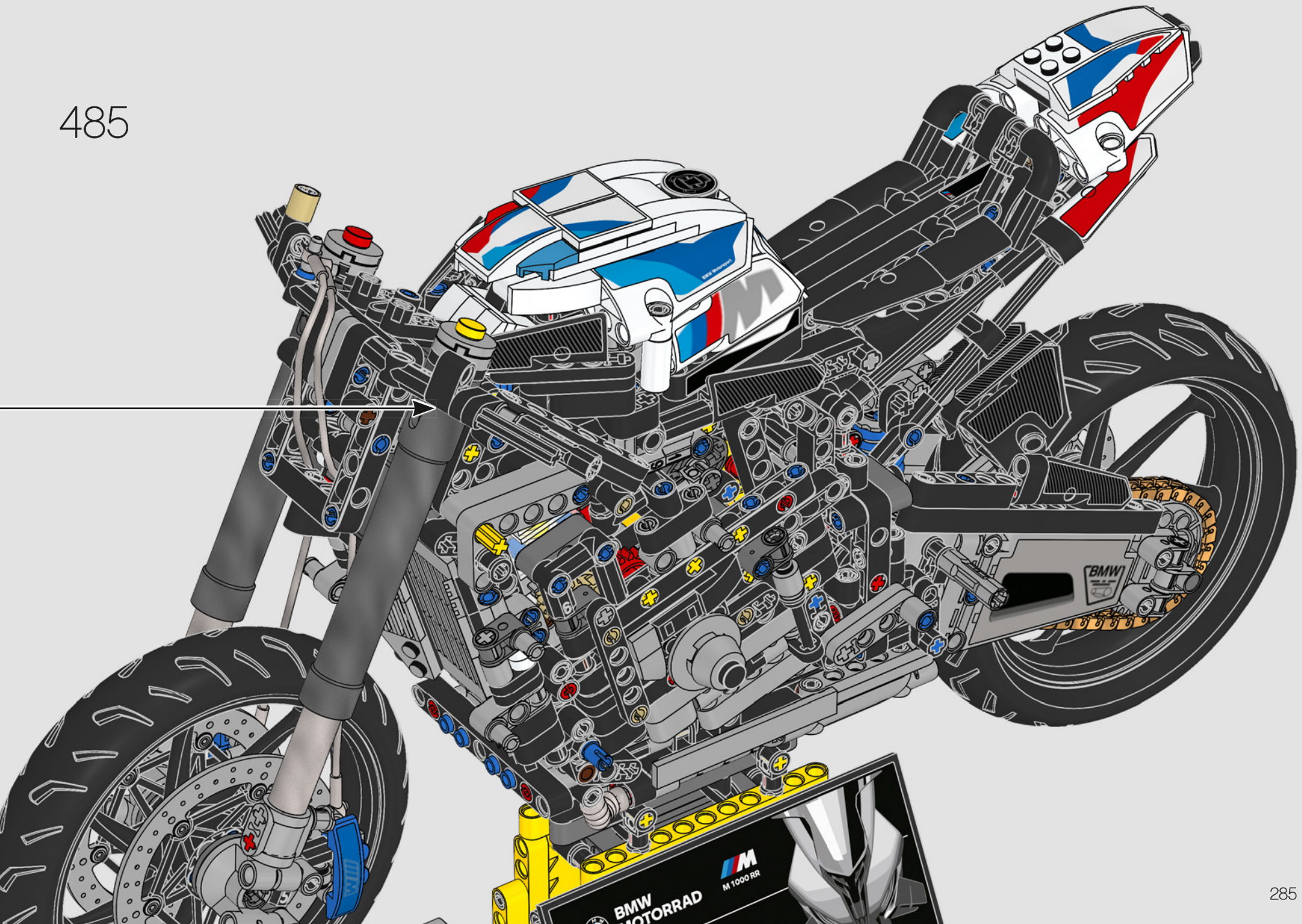

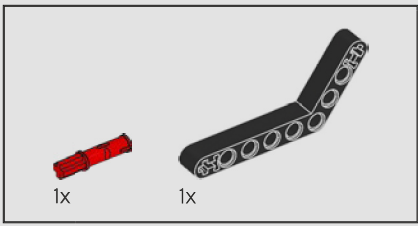

486

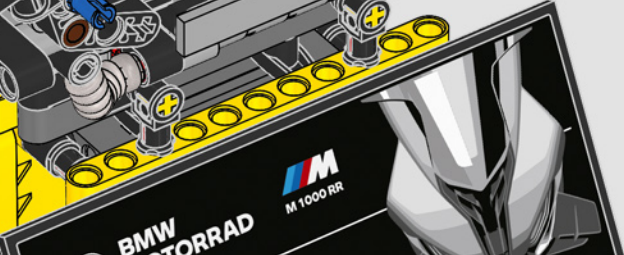
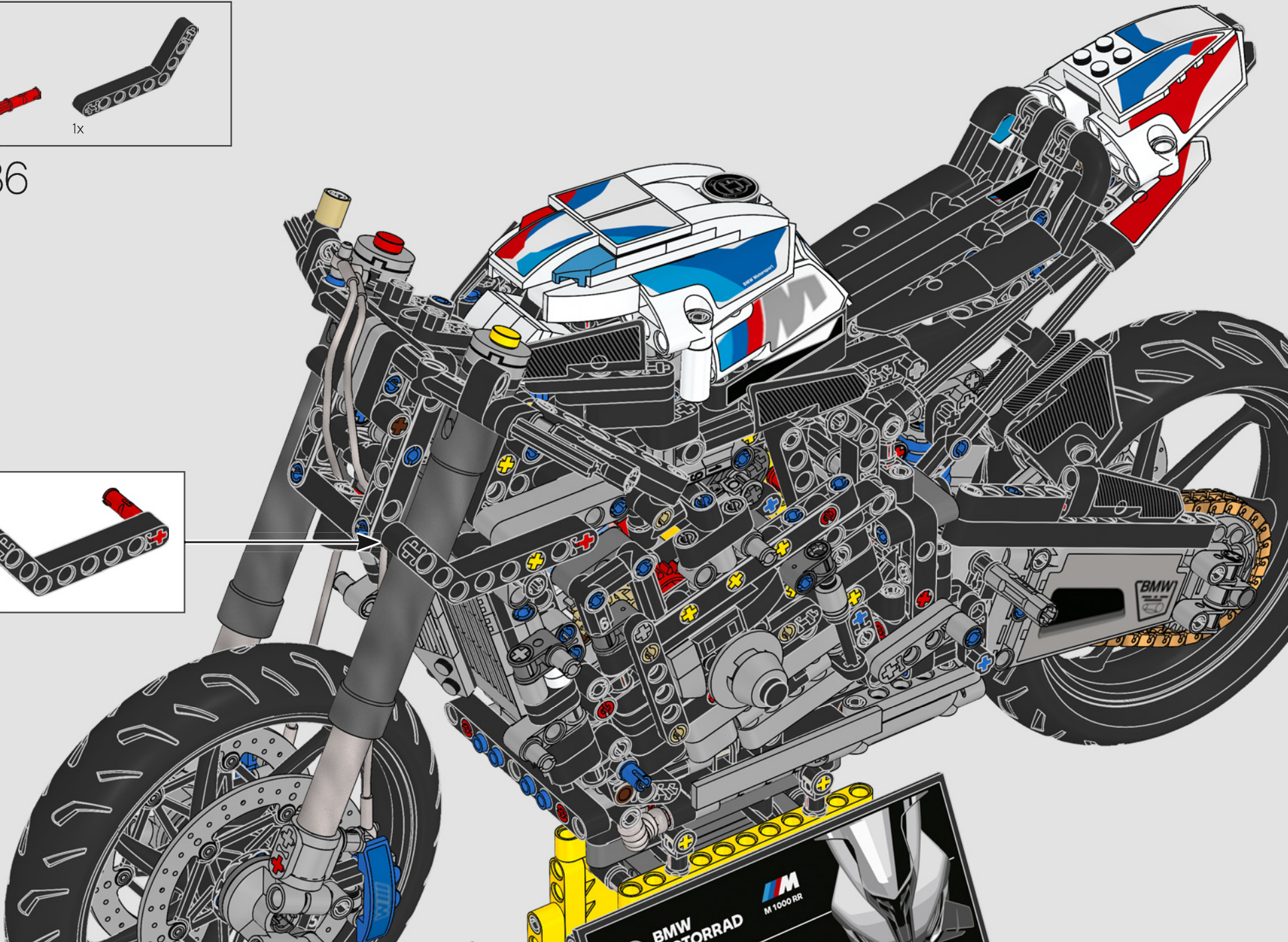
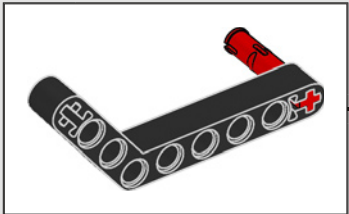

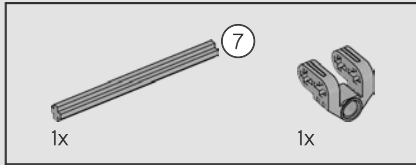
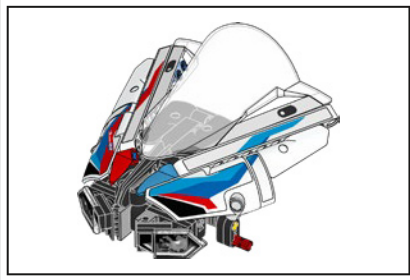

487

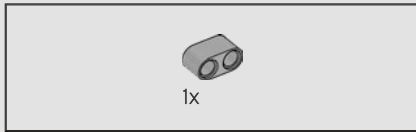
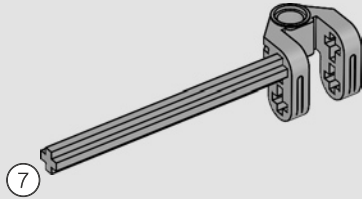

488

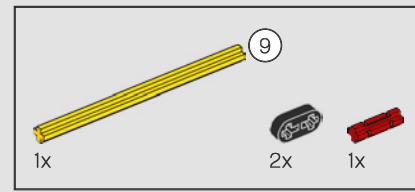
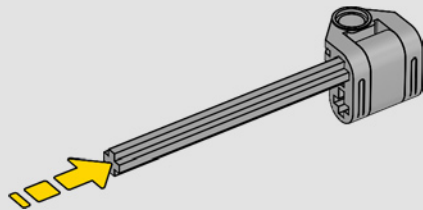

489

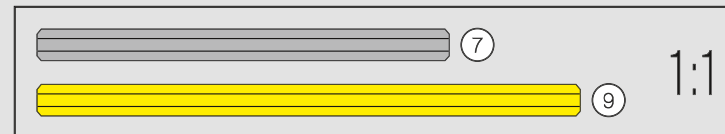
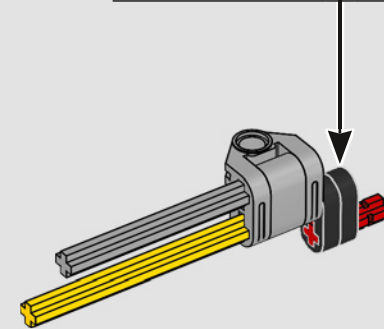
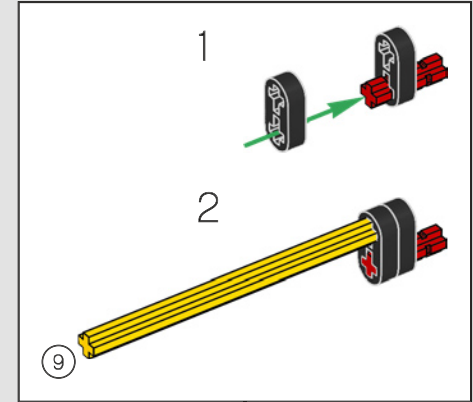

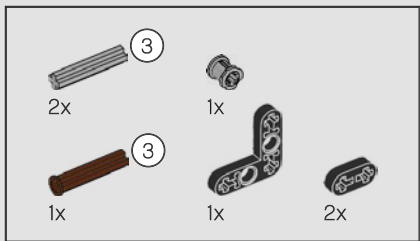

490

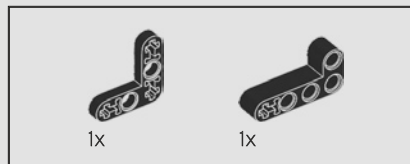
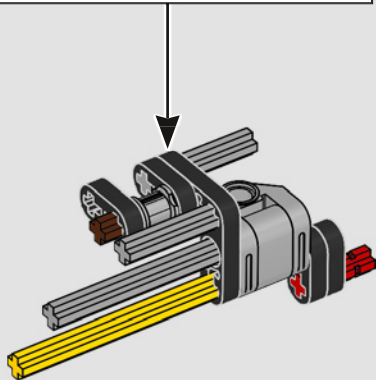
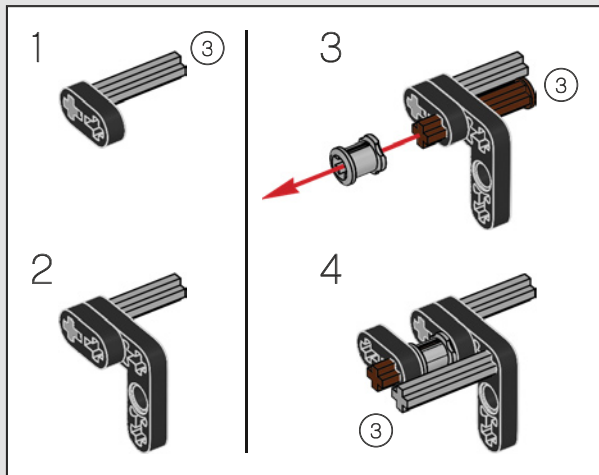

491

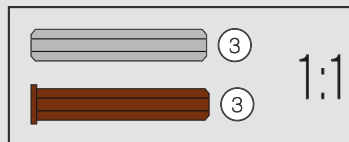
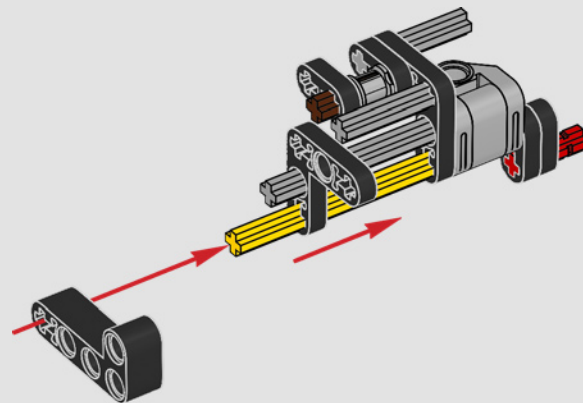

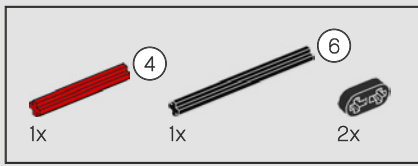

492

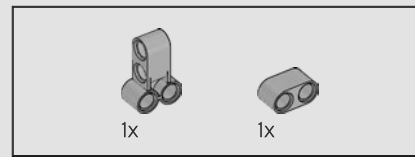
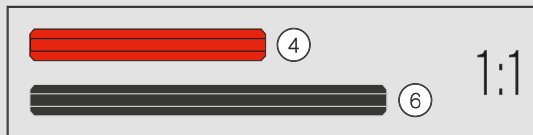
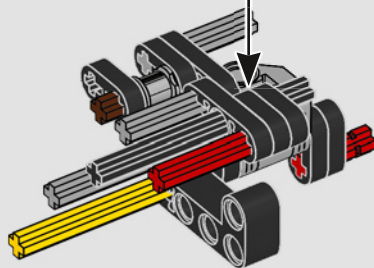
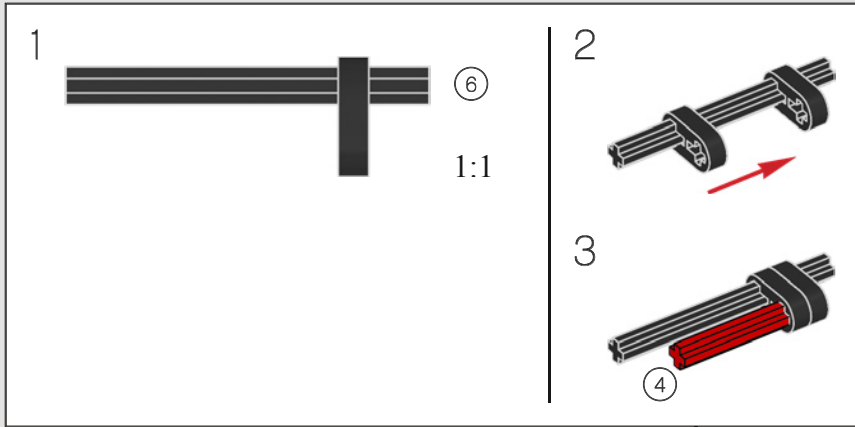

493

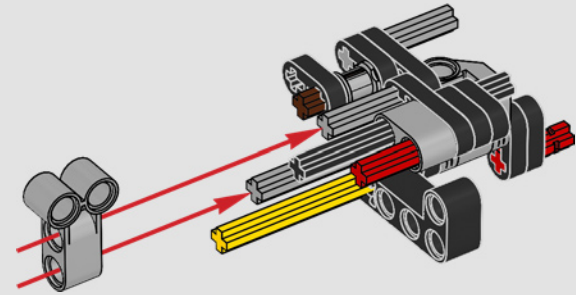

494

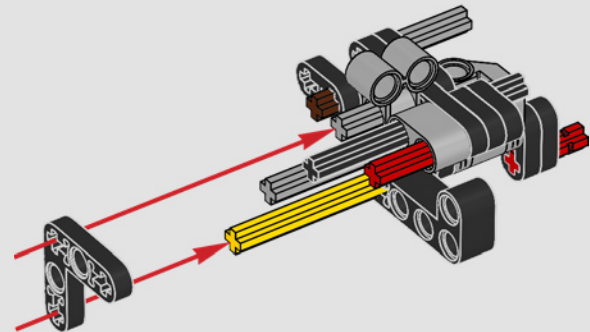

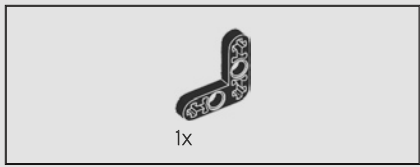

495

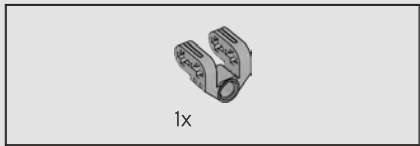
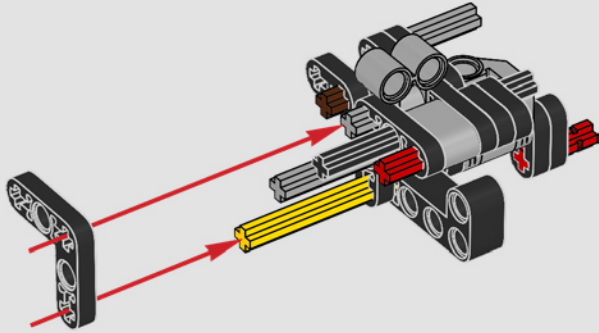

496

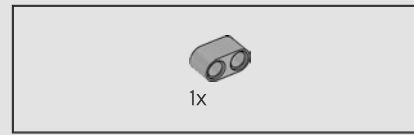
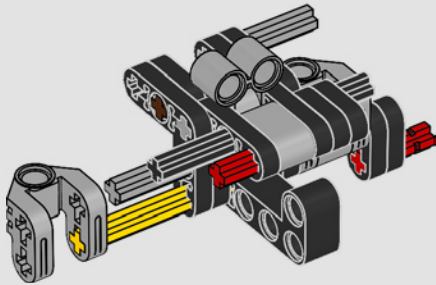

497

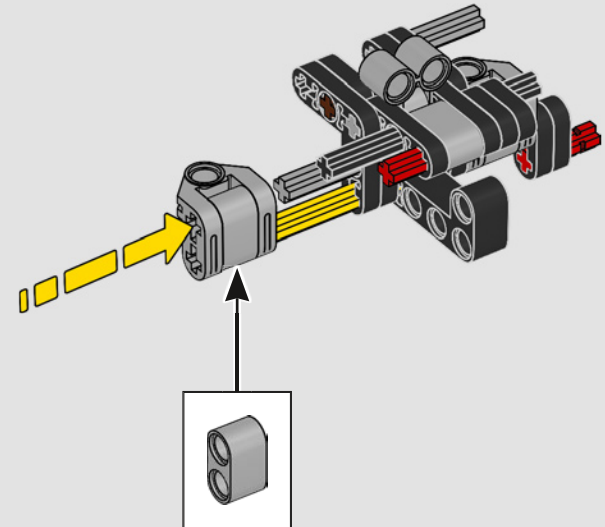

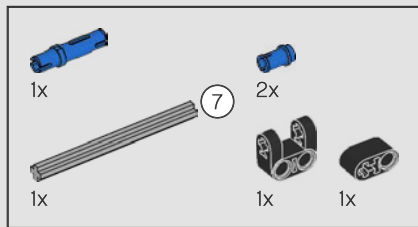

498

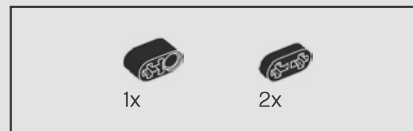
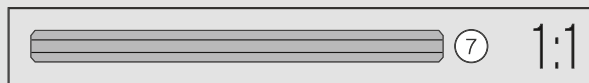
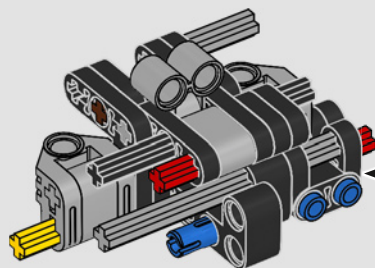
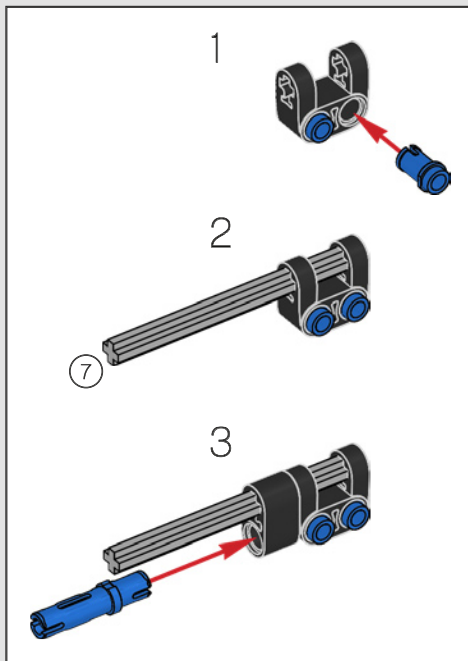

499

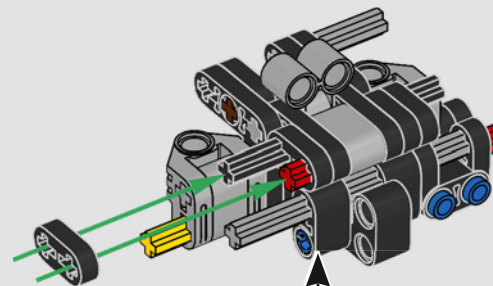

500

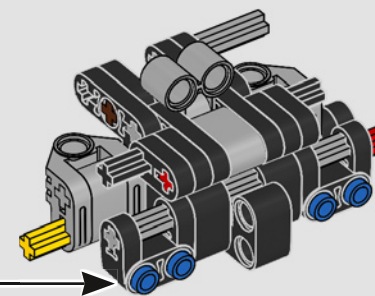
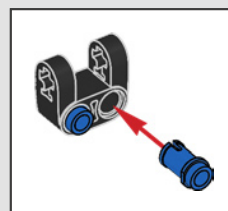



501

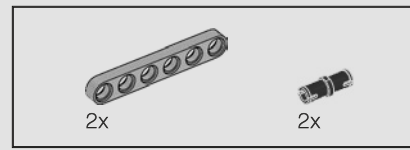
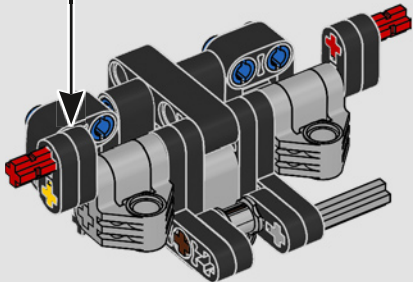
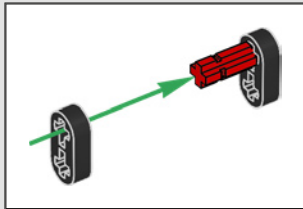

502

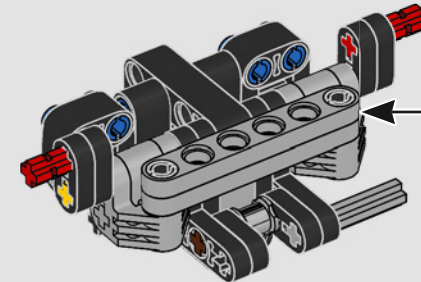
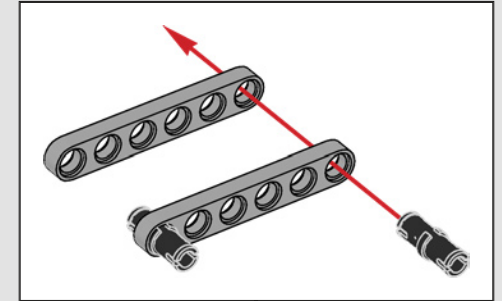

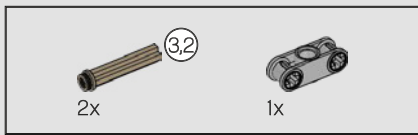

503

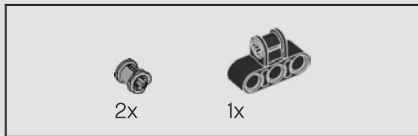
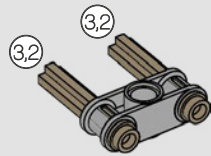
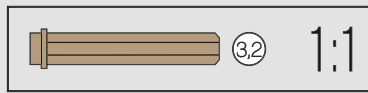

504

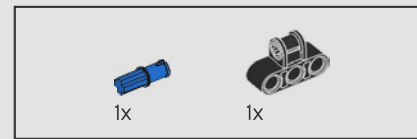
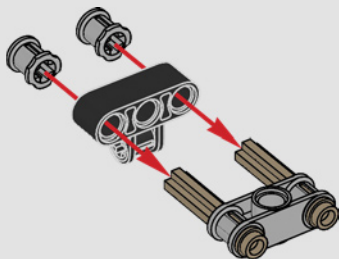

505

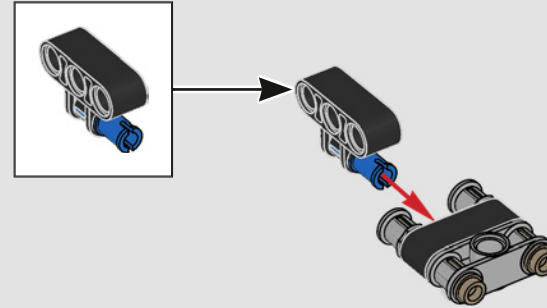

506

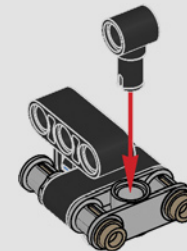

507

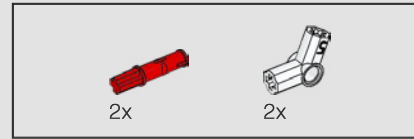
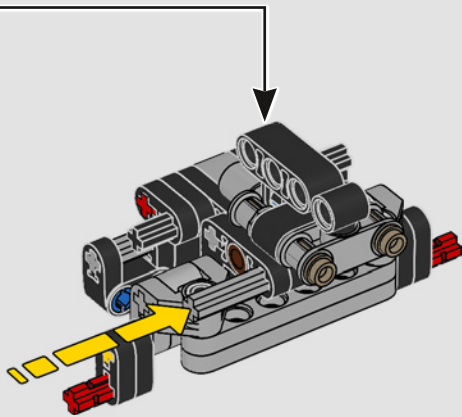

508

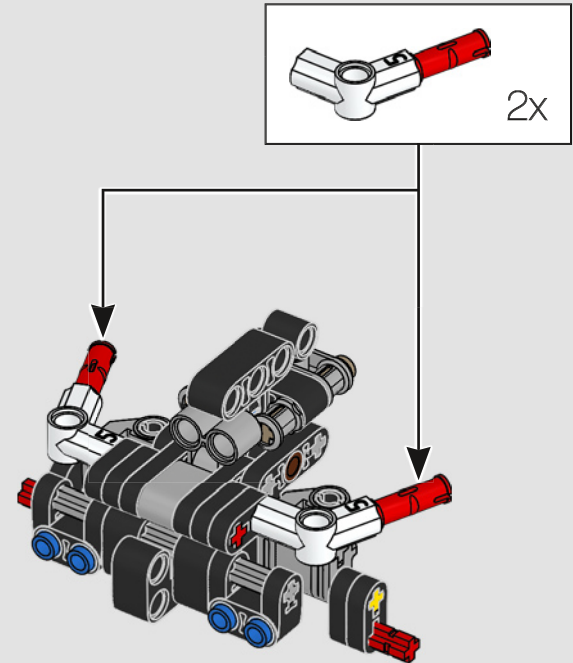

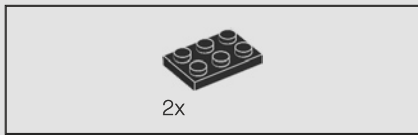

509

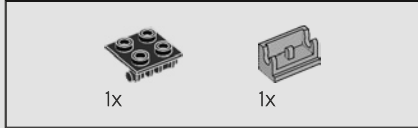
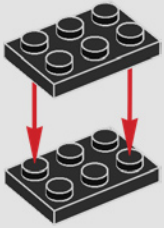

510

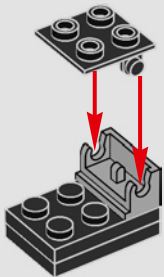

511

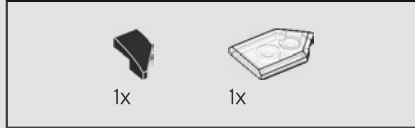
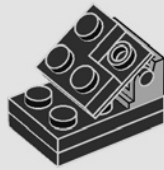

512

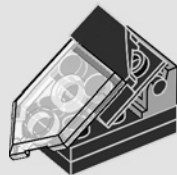

513

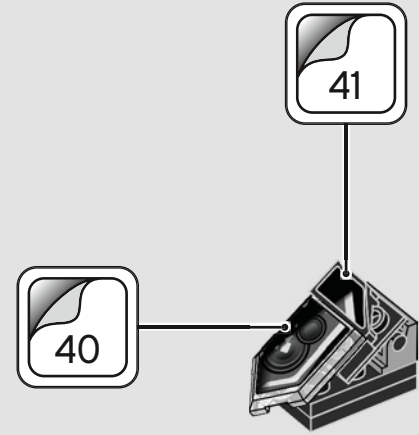

514

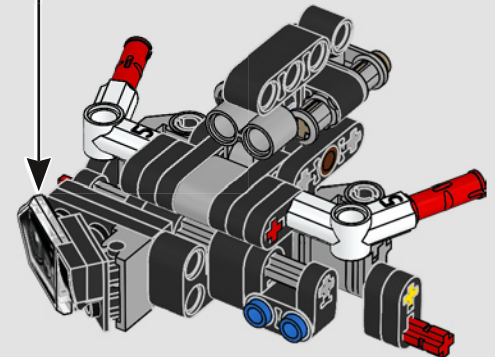

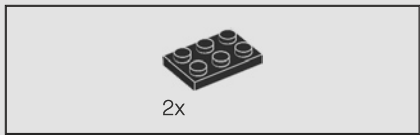

515

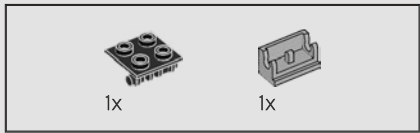
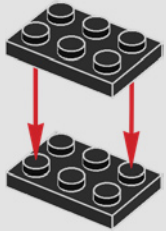

516

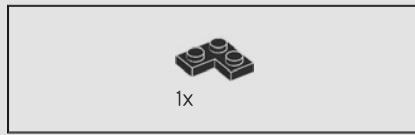
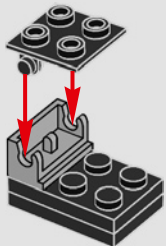

517

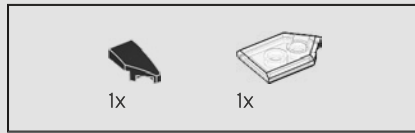
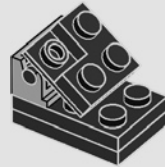

518

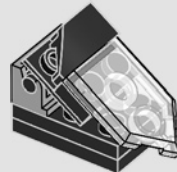

519

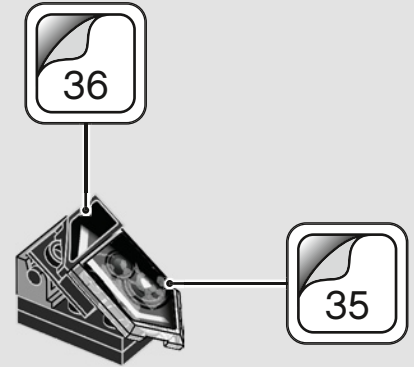

520

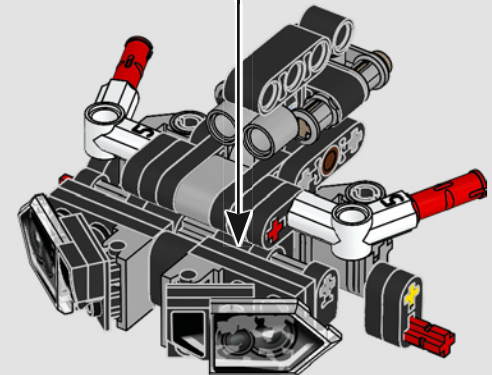

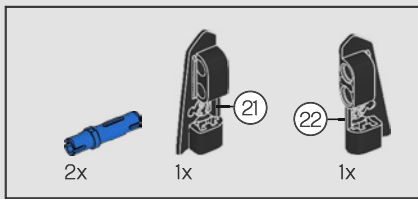

521

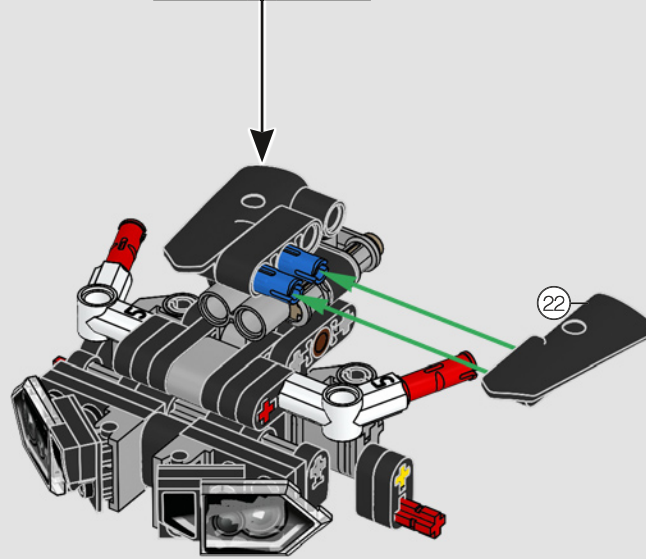
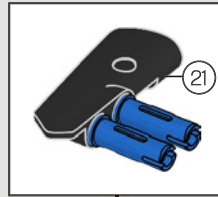

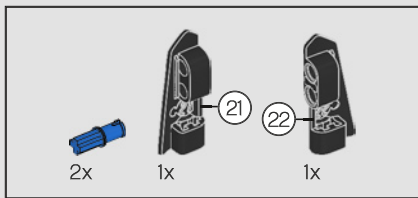

522

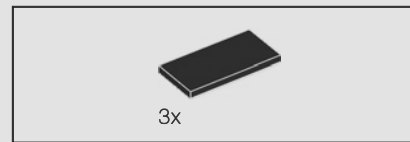
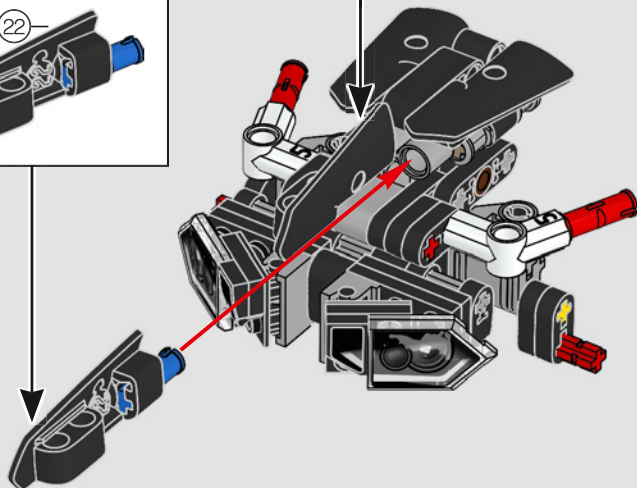
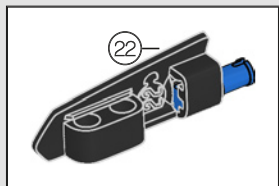
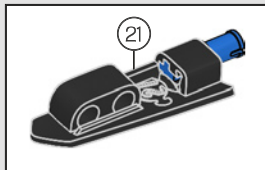

523

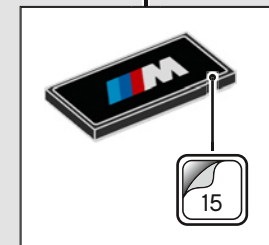
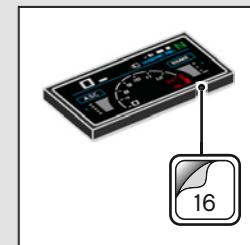
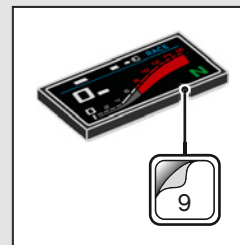
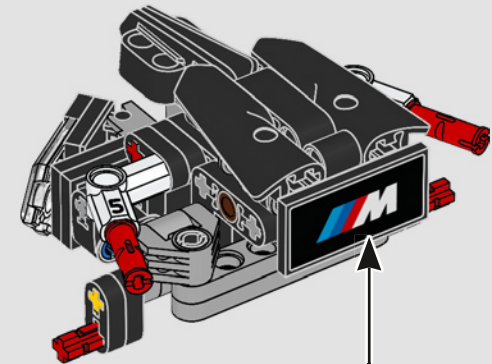

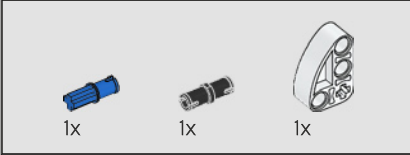
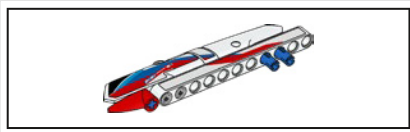

524

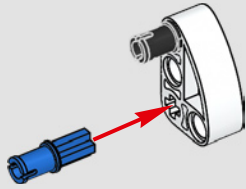

525

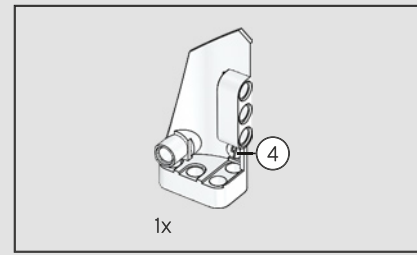
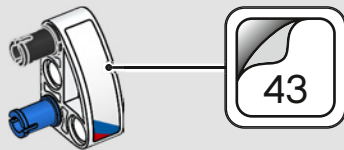

526



527

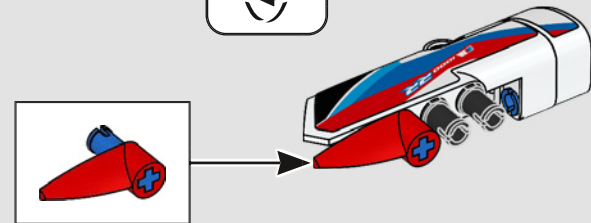
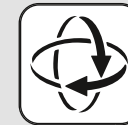

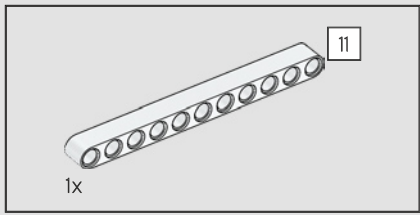

528

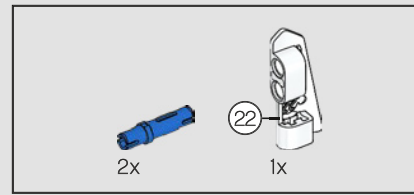
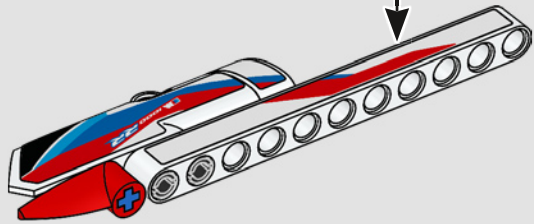
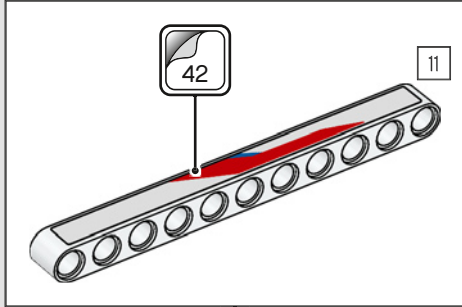

529

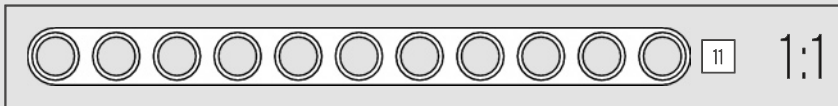
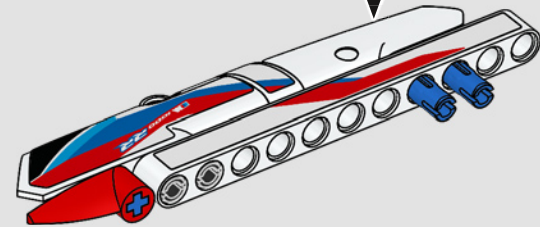
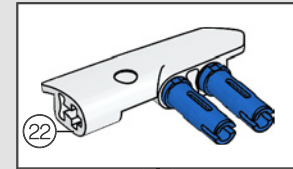

530

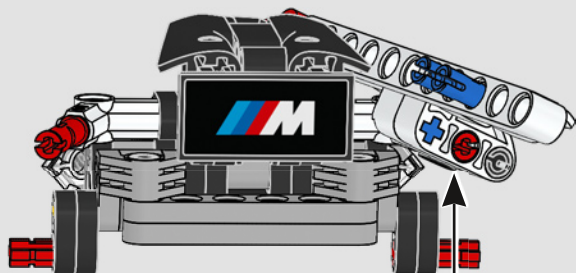

531

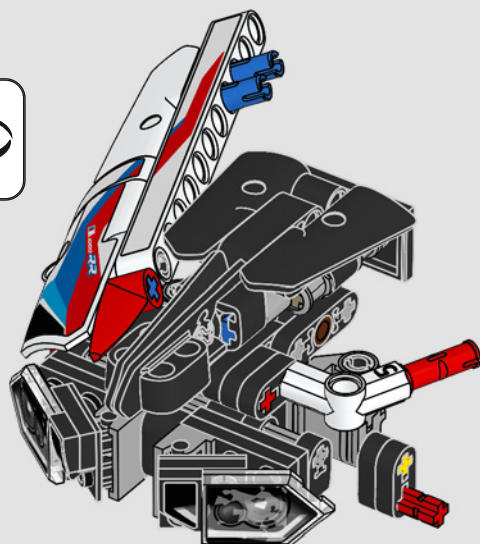

532

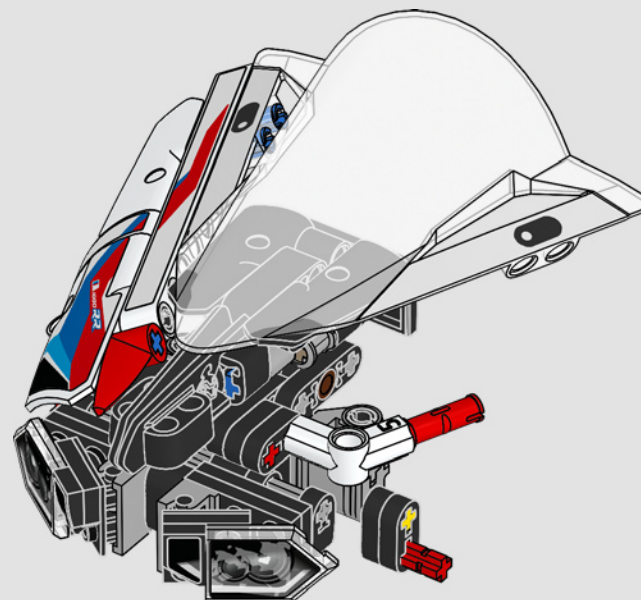
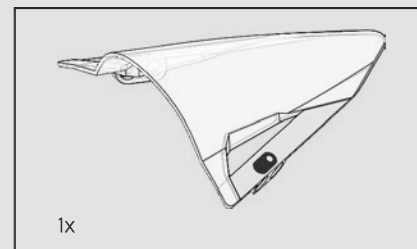

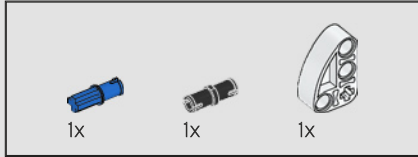
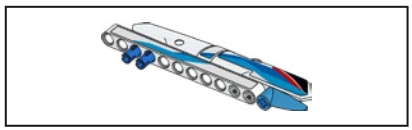

533

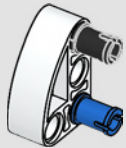

534

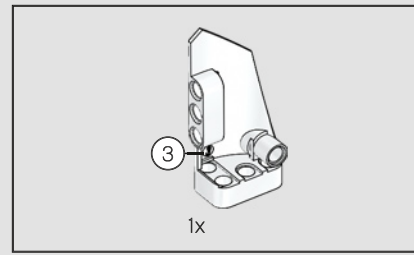
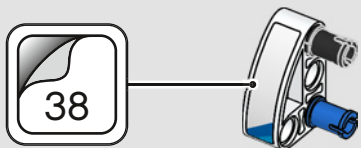

535

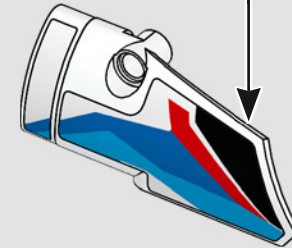
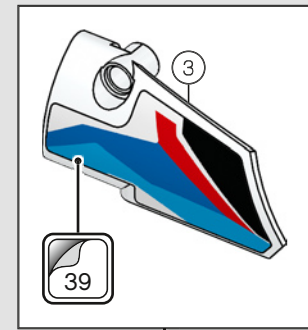

536

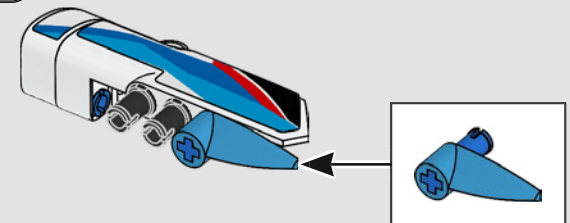
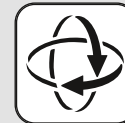

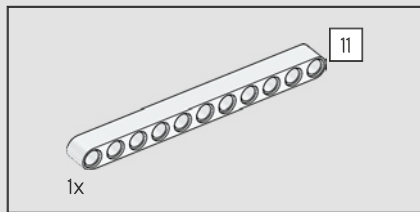

537

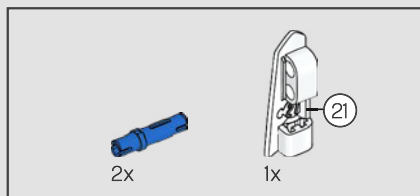
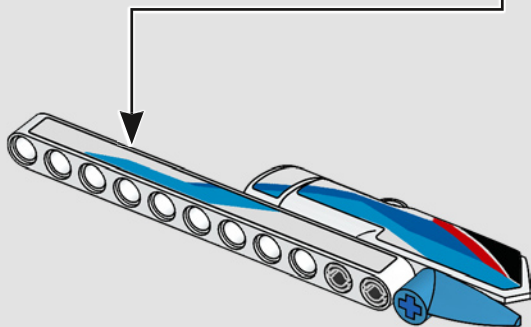
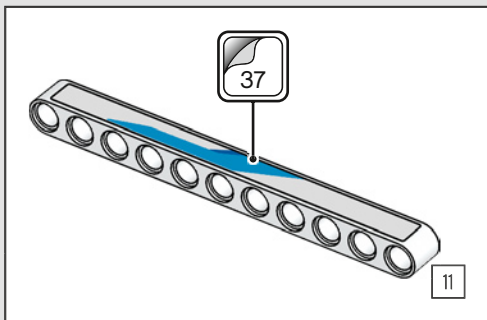

538

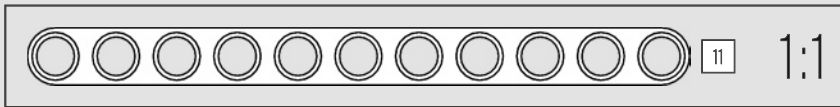
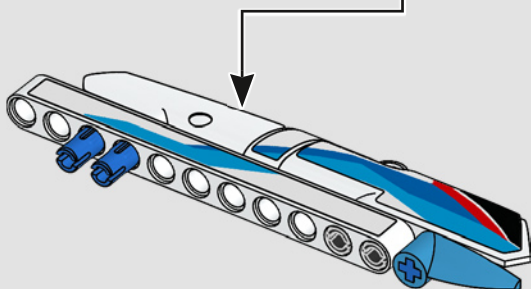
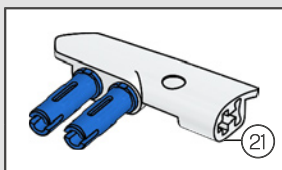

539

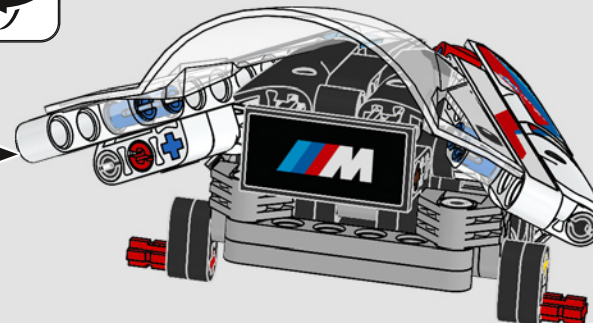

540

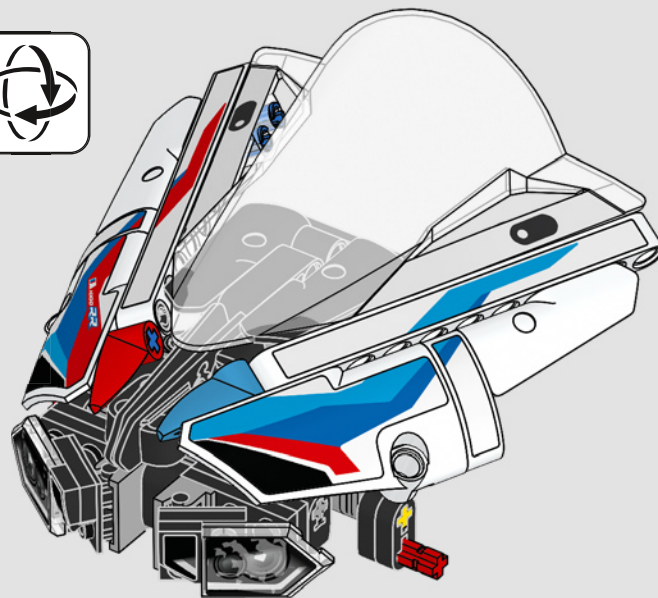

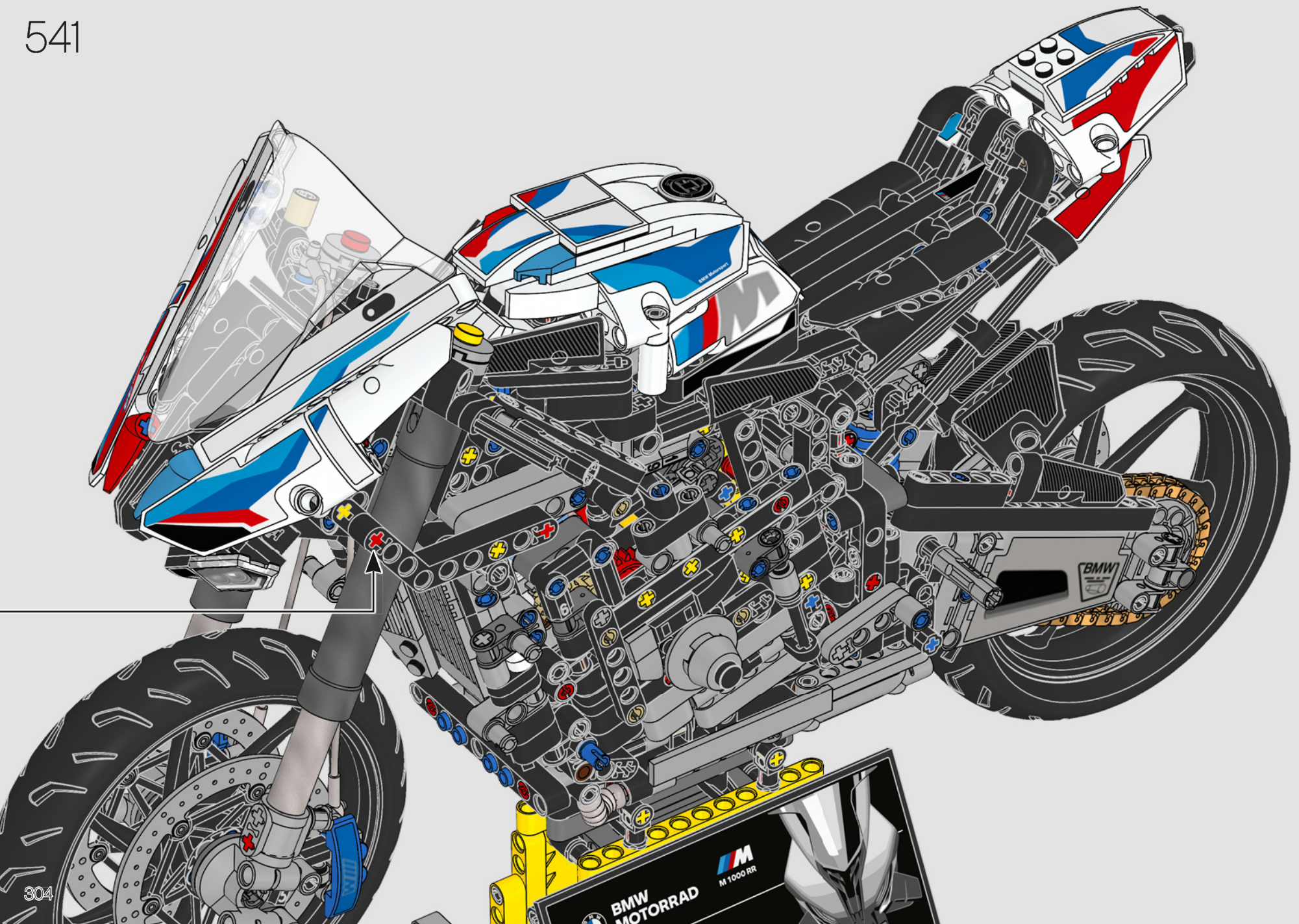

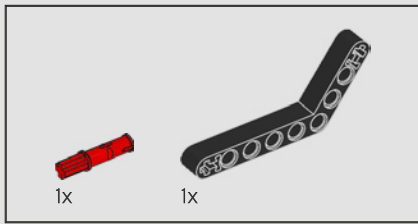

542

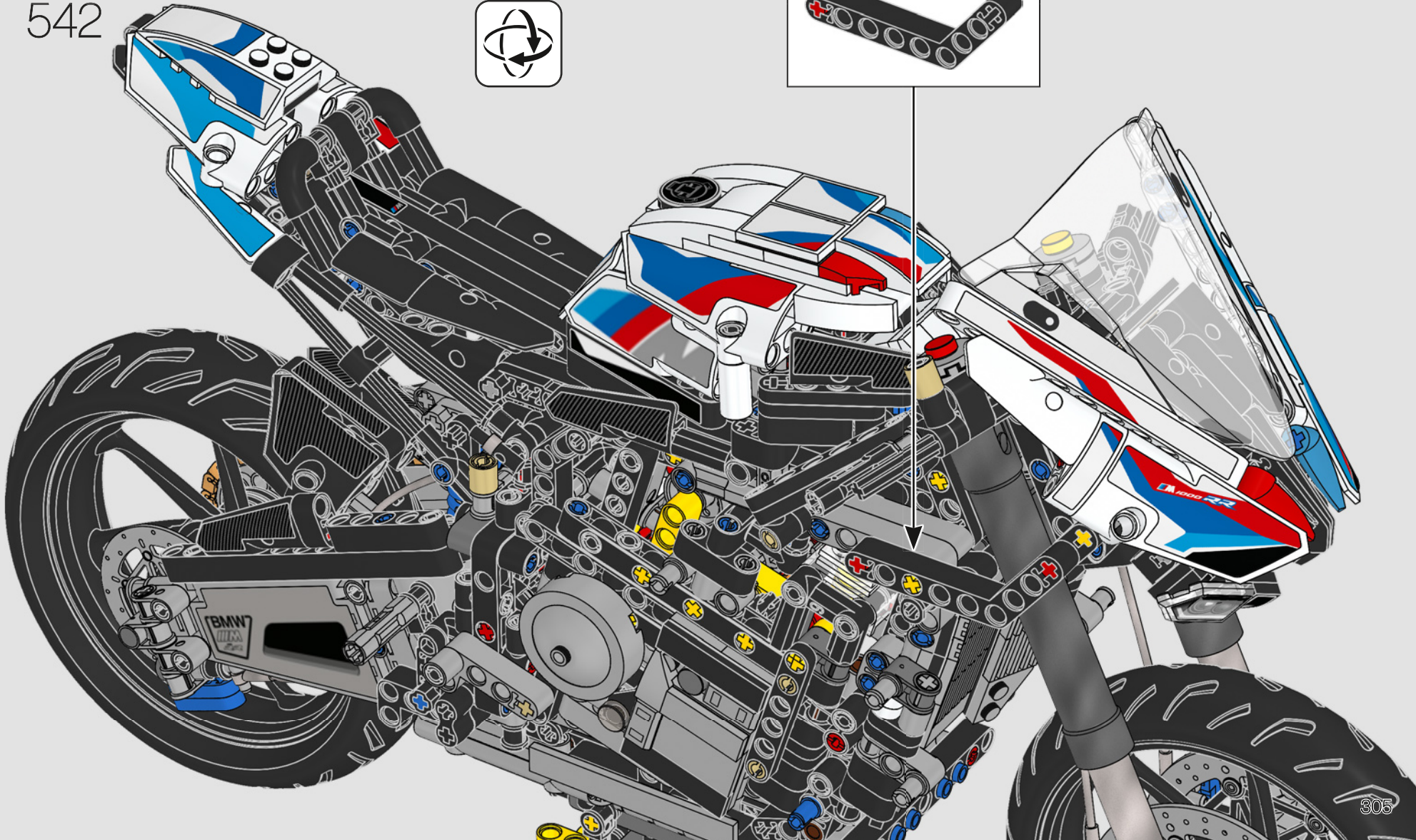
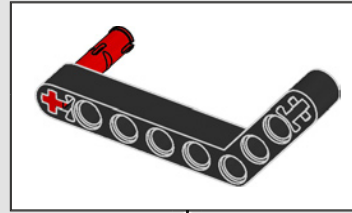

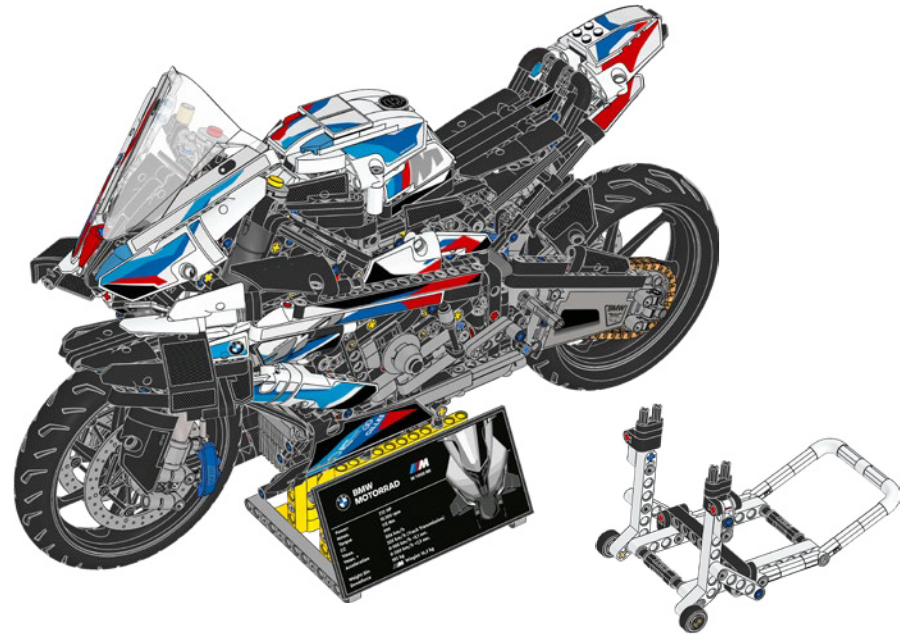
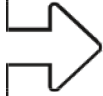

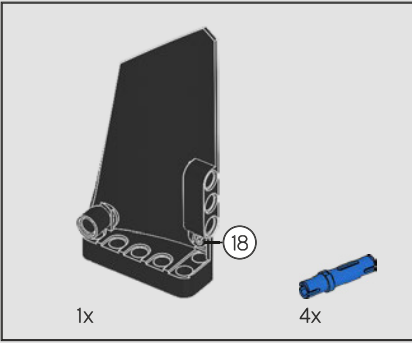
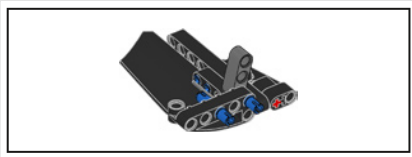

543

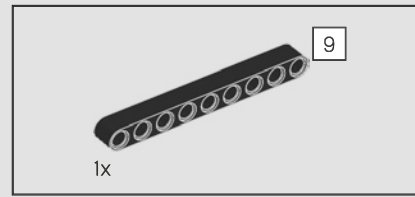
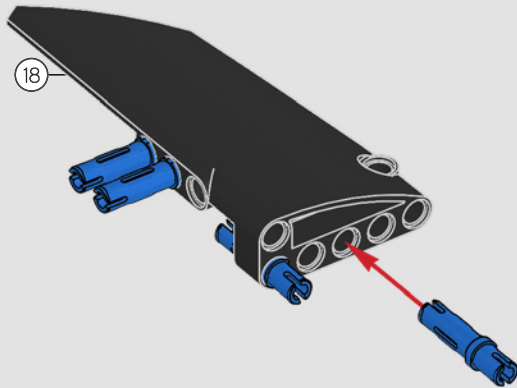

544

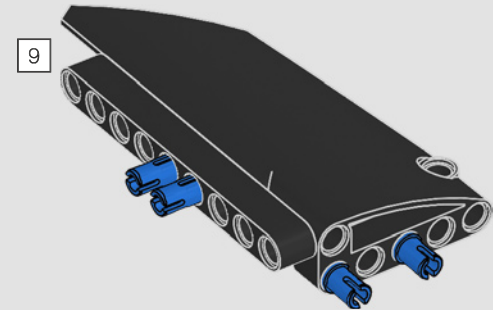

545

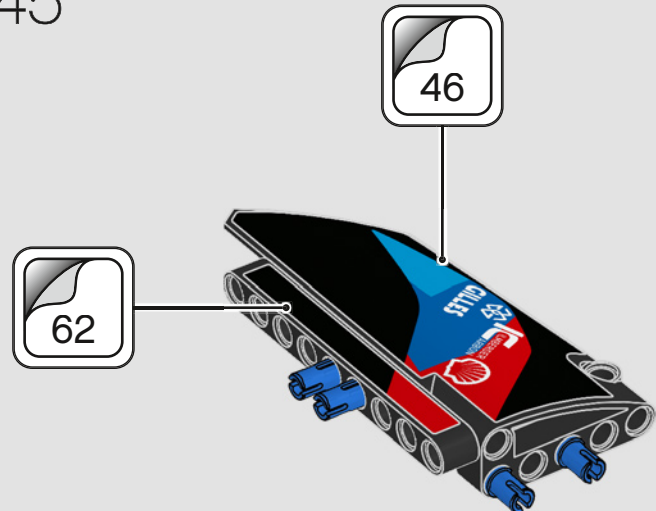

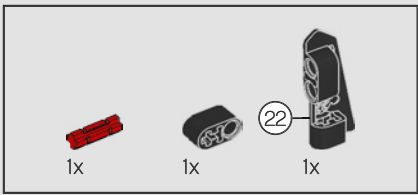

546

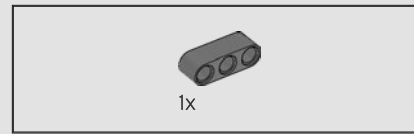
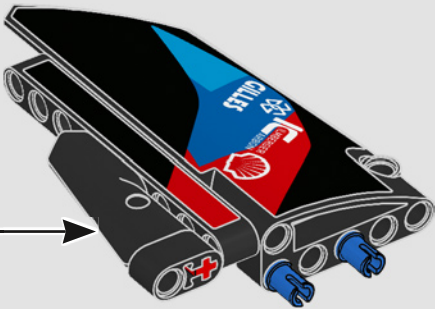
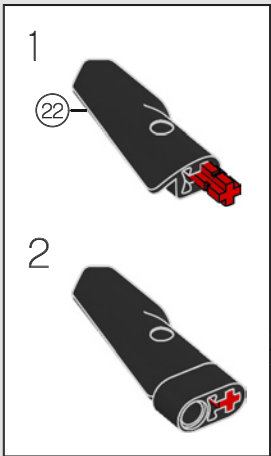

547

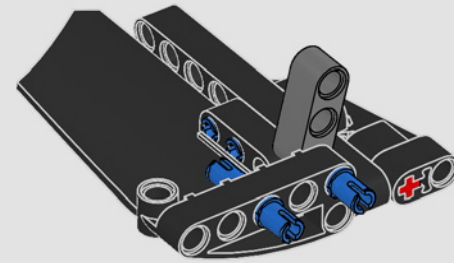

548

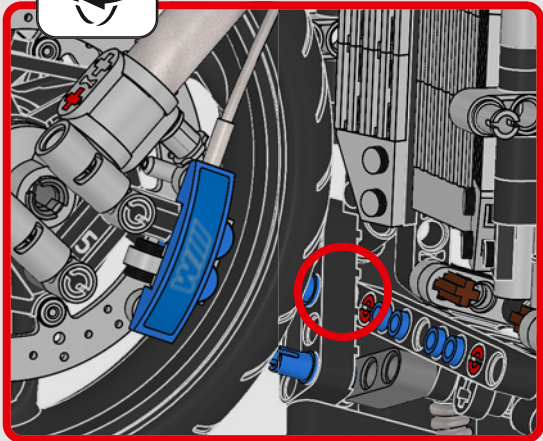
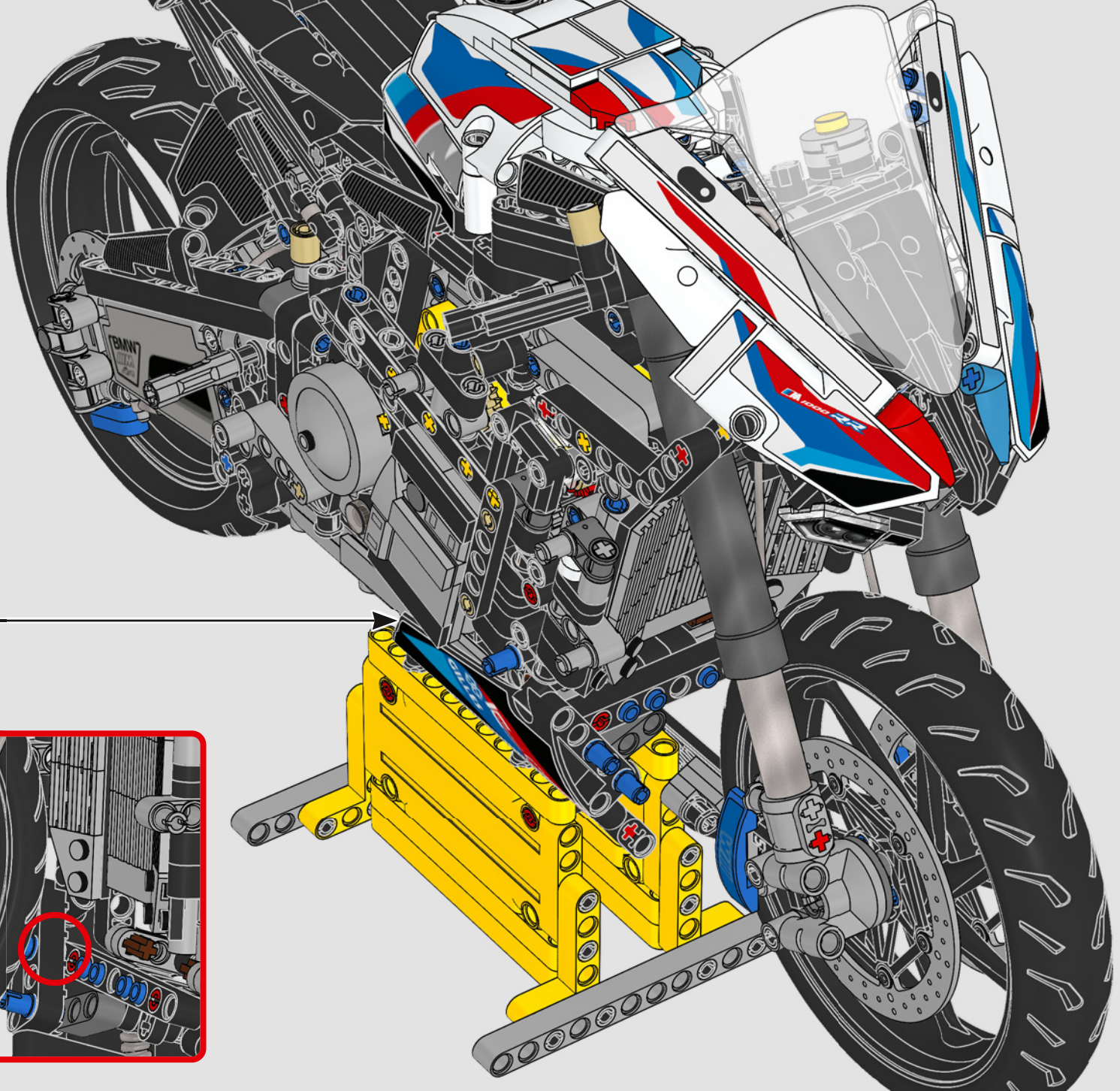

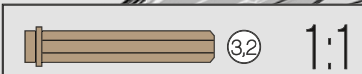
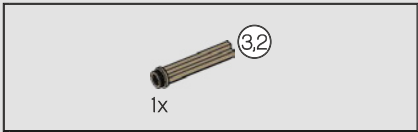

549

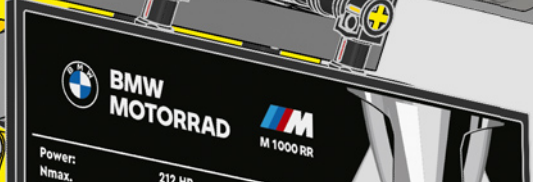
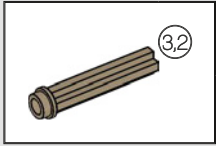
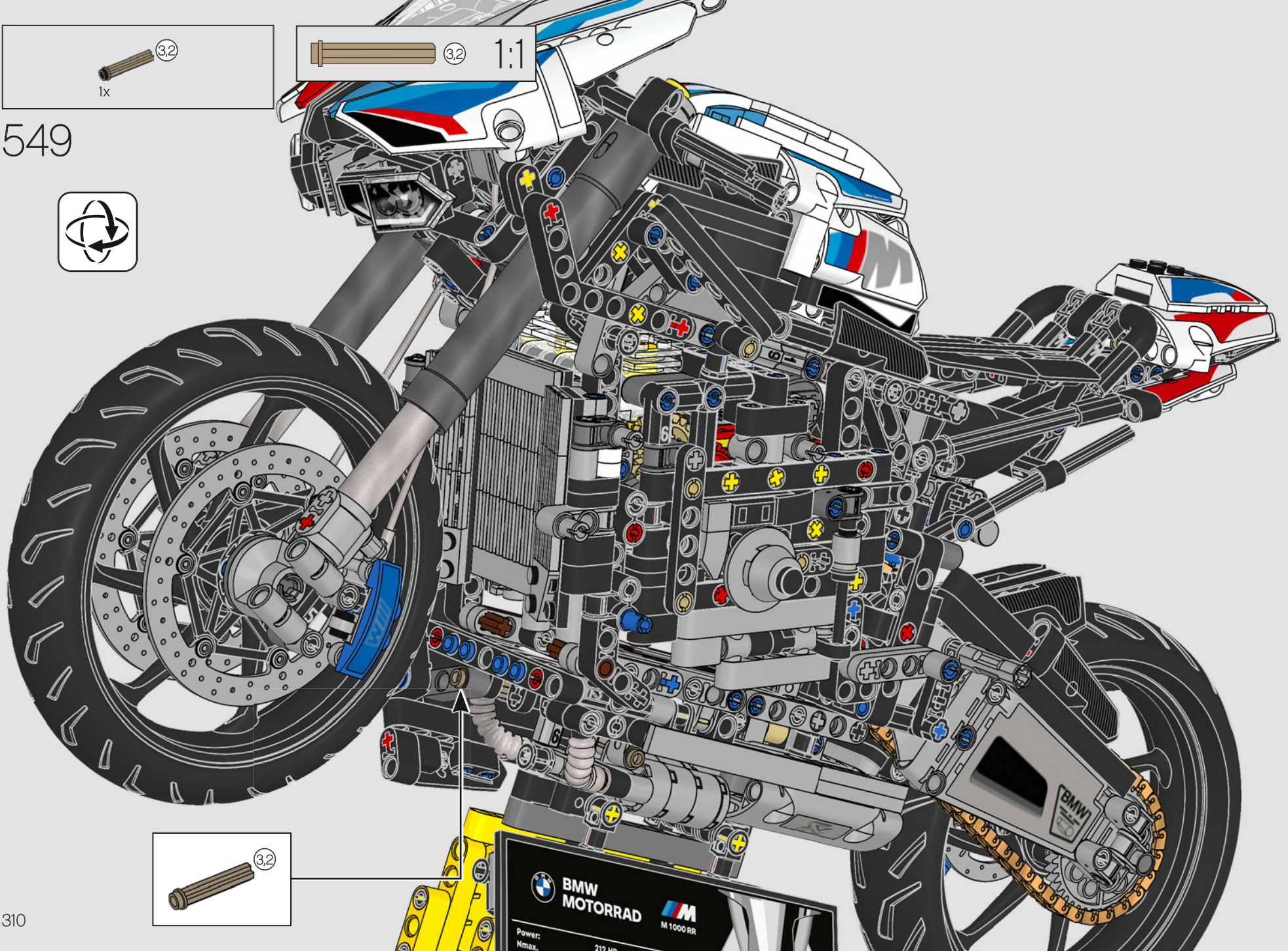

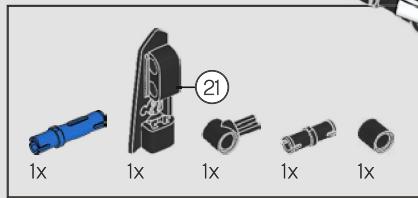

550

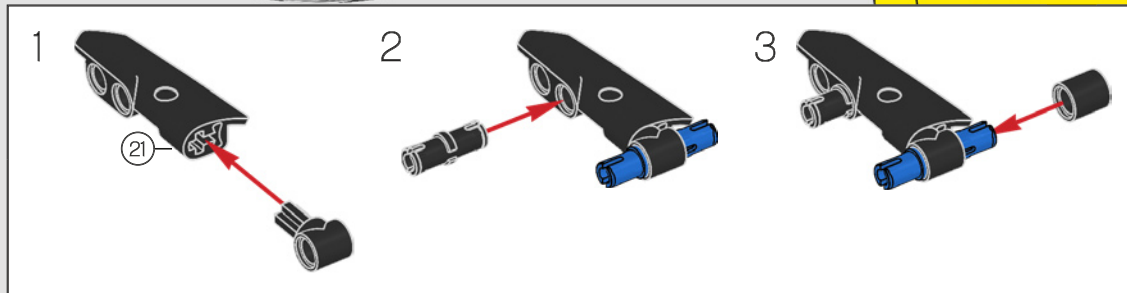
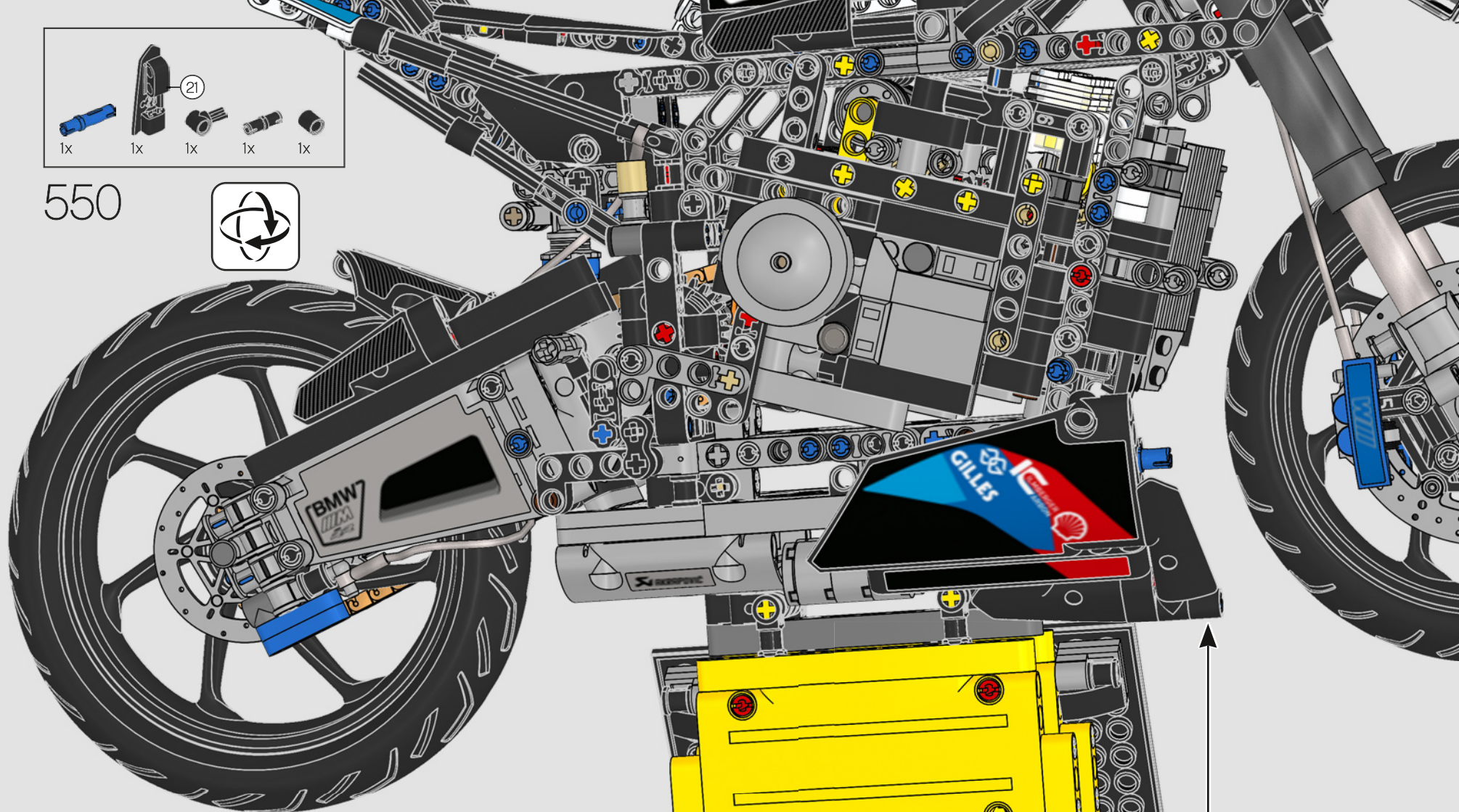

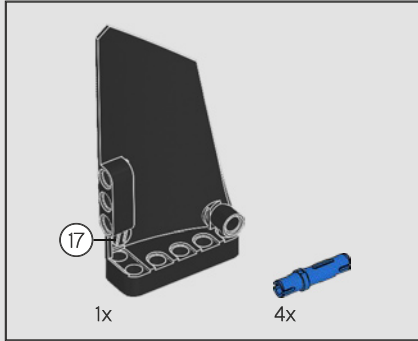
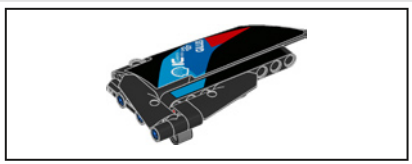

551

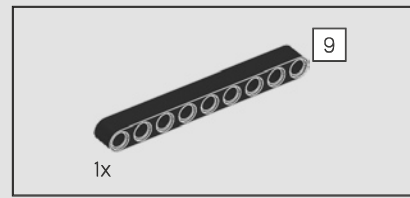
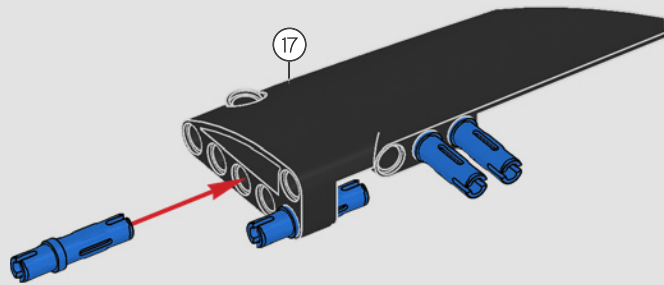

552

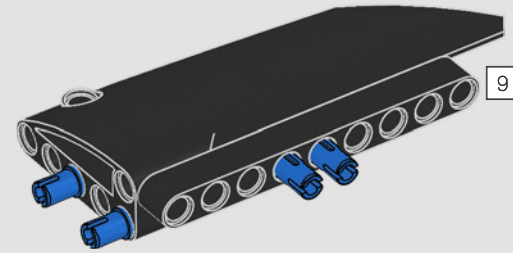

553

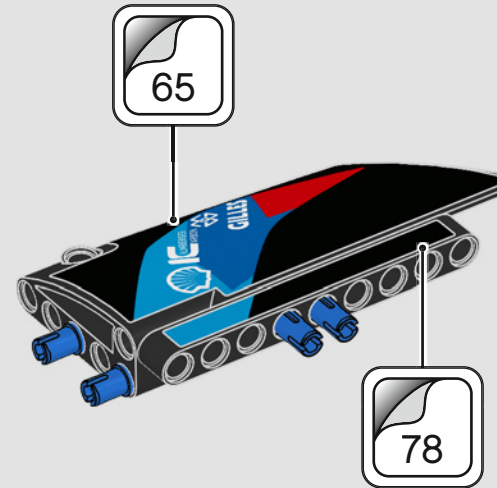

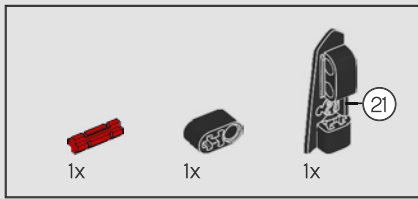

554

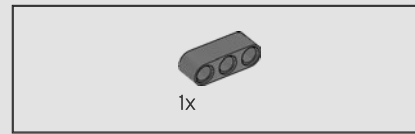
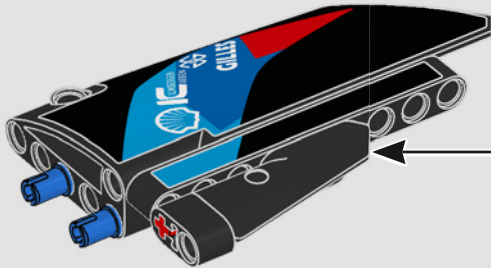
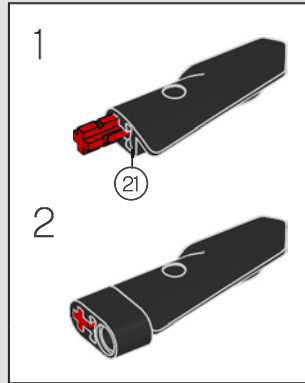

555

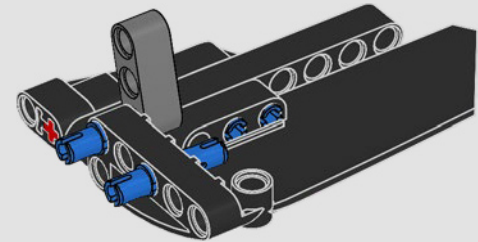

556

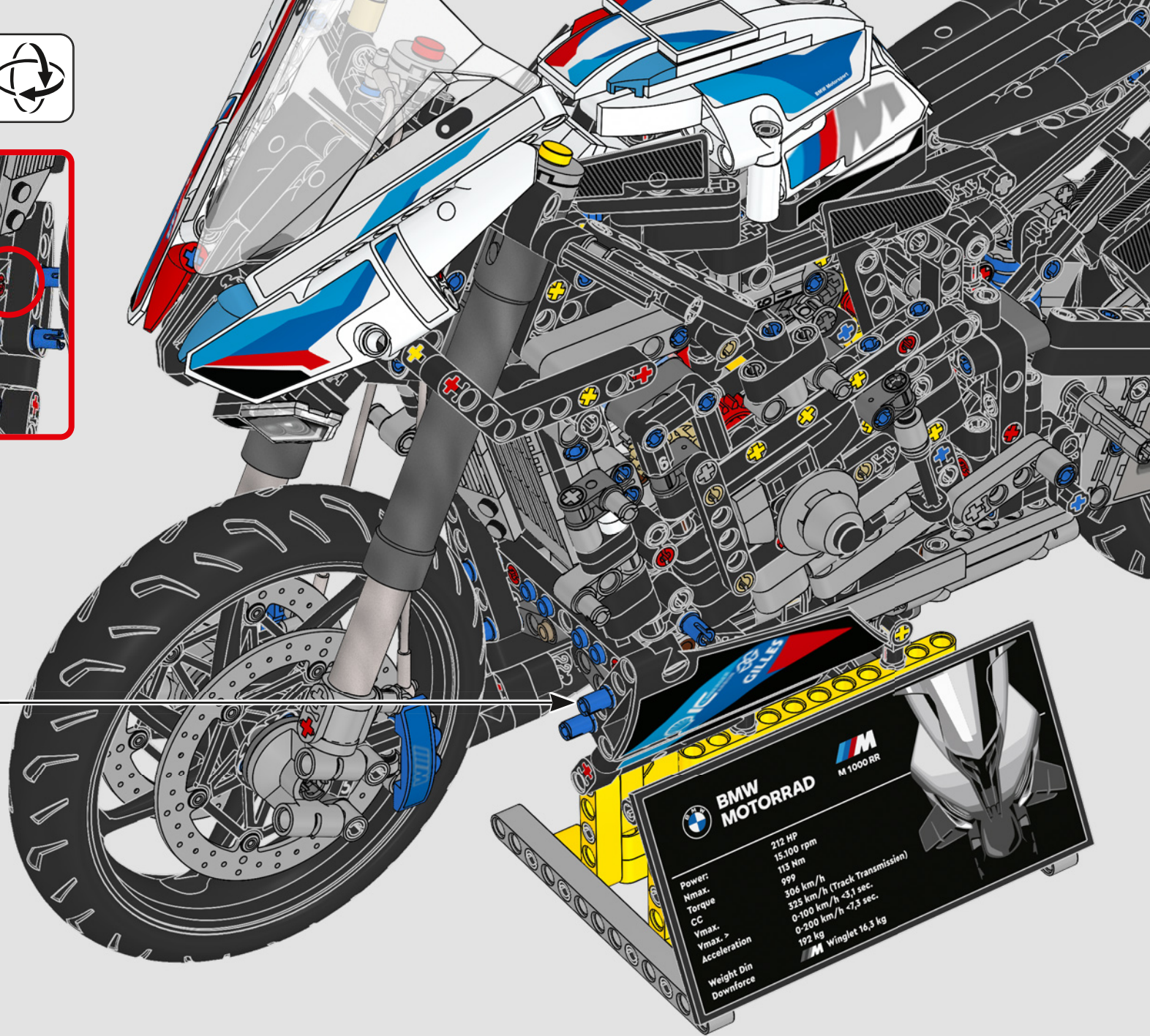
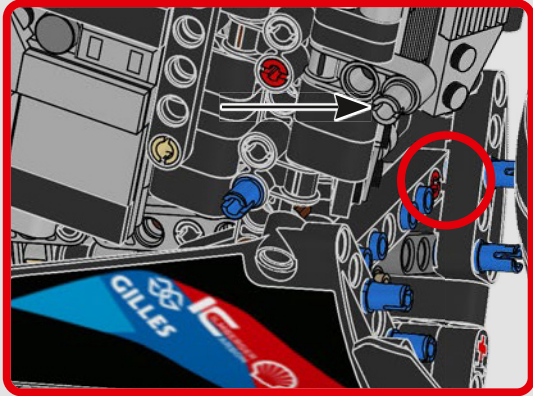

BMW MOTORRAD  **M 1000 RR**

Power:	212 HP
Nmax:	15,100 rpm
Torque:	113 Nm
CC	999
Vmax:	306 km/h
Acceleration	0-100 km/h <3,1 sec.
Weight Din	0-200 km/h <7,3 sec.
Downforce	192 kg
	Winglet 16,3 kg



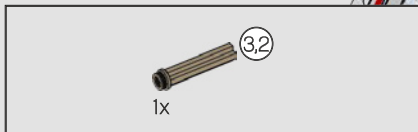

557

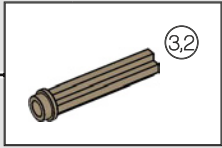
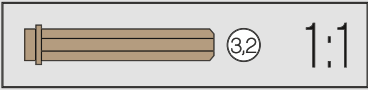
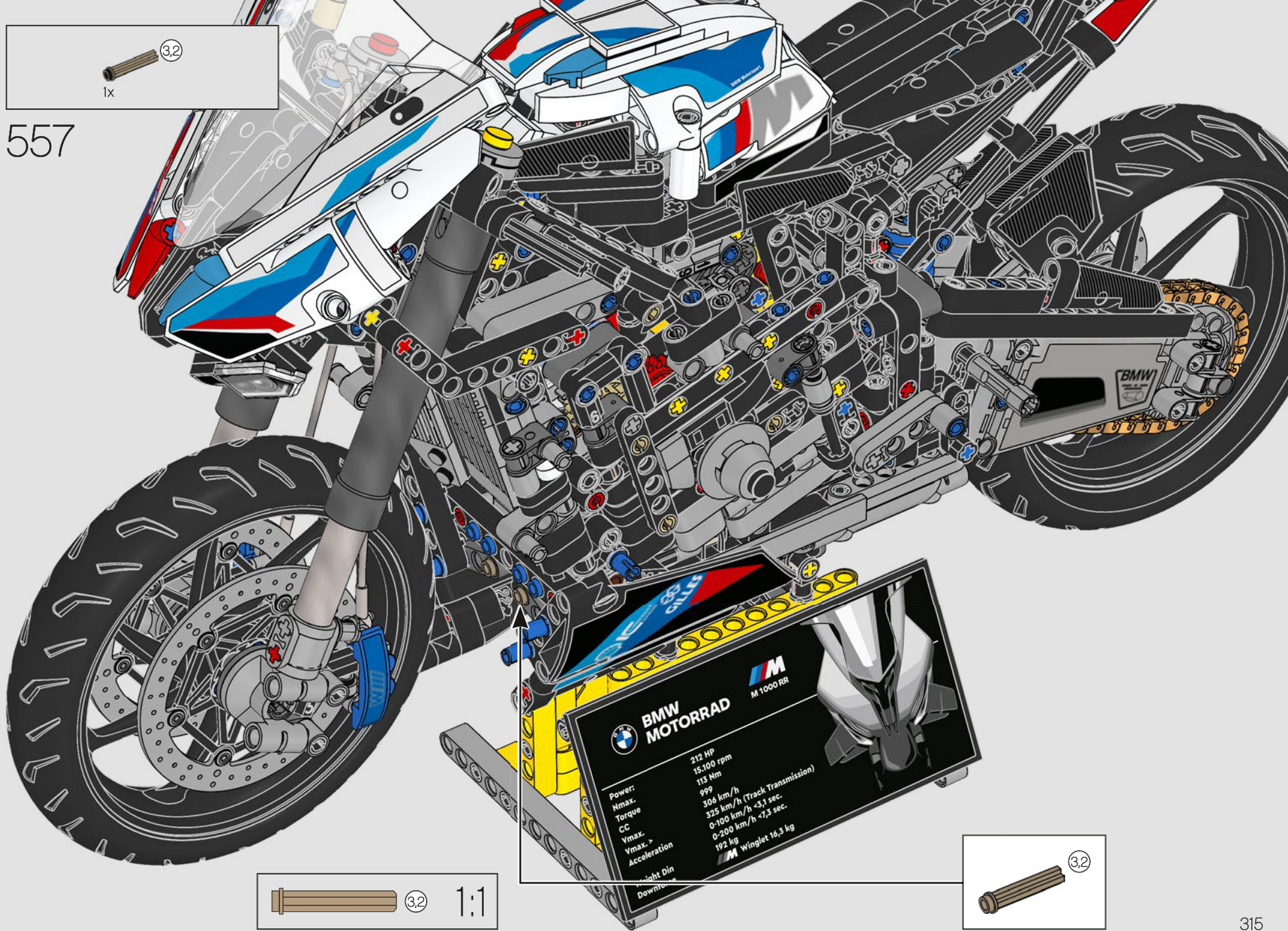

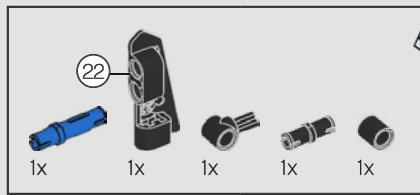

558

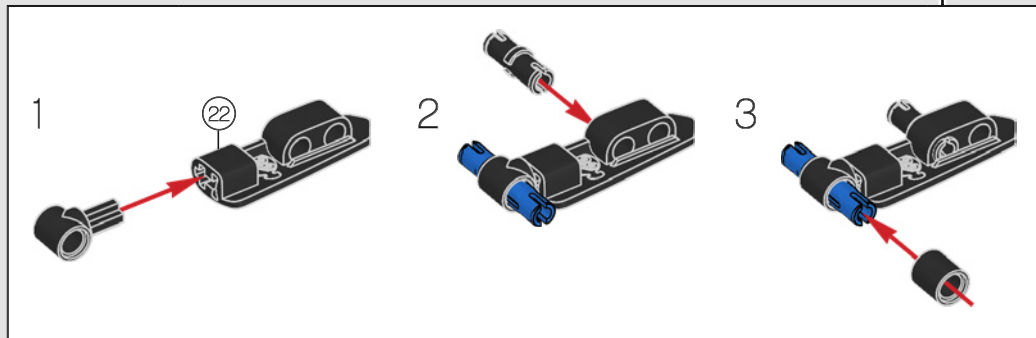
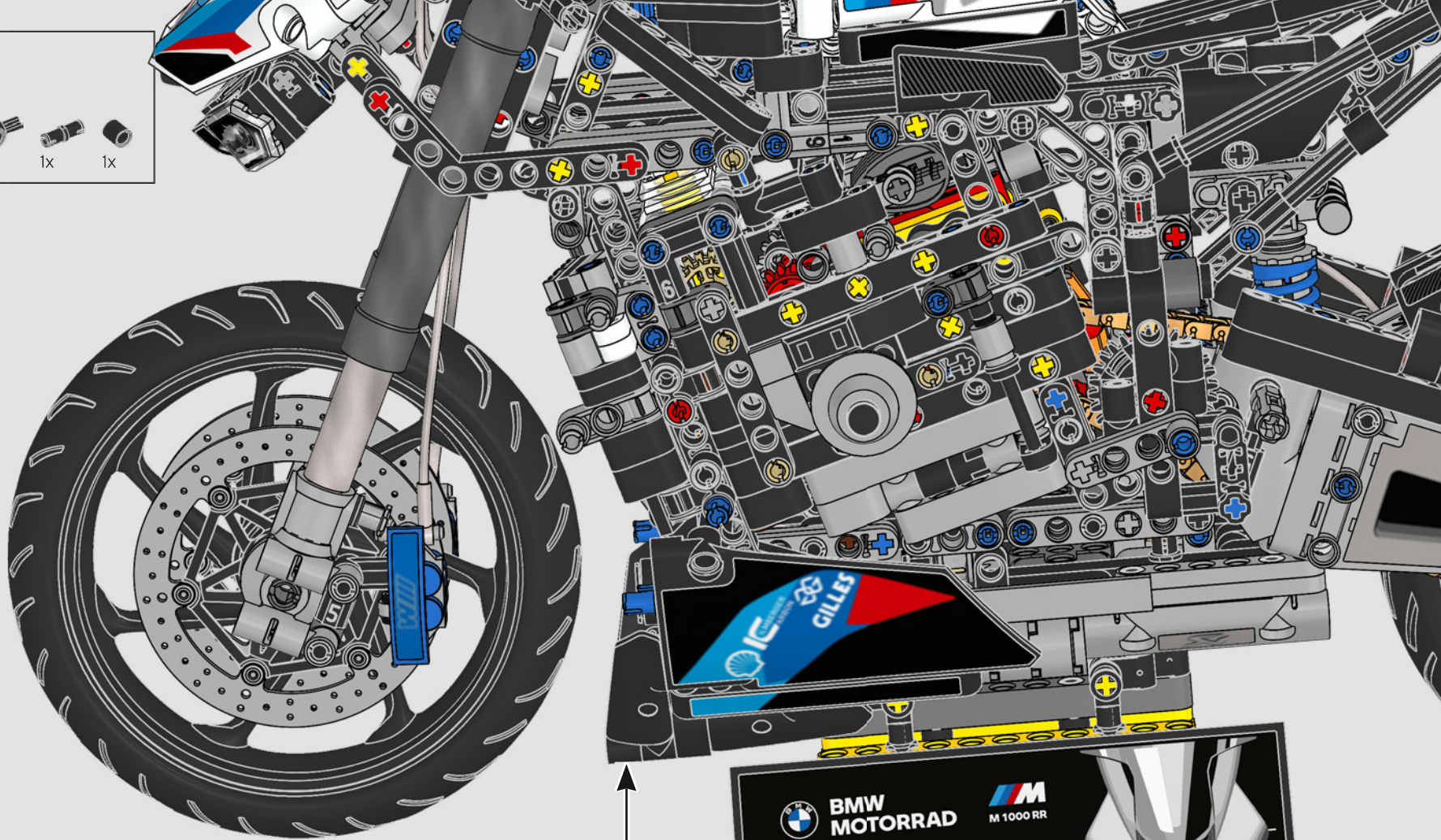

BMW MOTORRAD **M 1000 RR**

Power:	212 HP
Nmax.	15.100 rpm
Torque	113 Nm
CC	999
Vmax.	306 km/h
Vmax. >	325 km/h (Track Transmission)
Acceleration	0-100 km/h <3,1 sec.
	0-200 km/h <7,3 sec.
Weight Din	192 kg
Downforce	M Winglet 16,3 kg

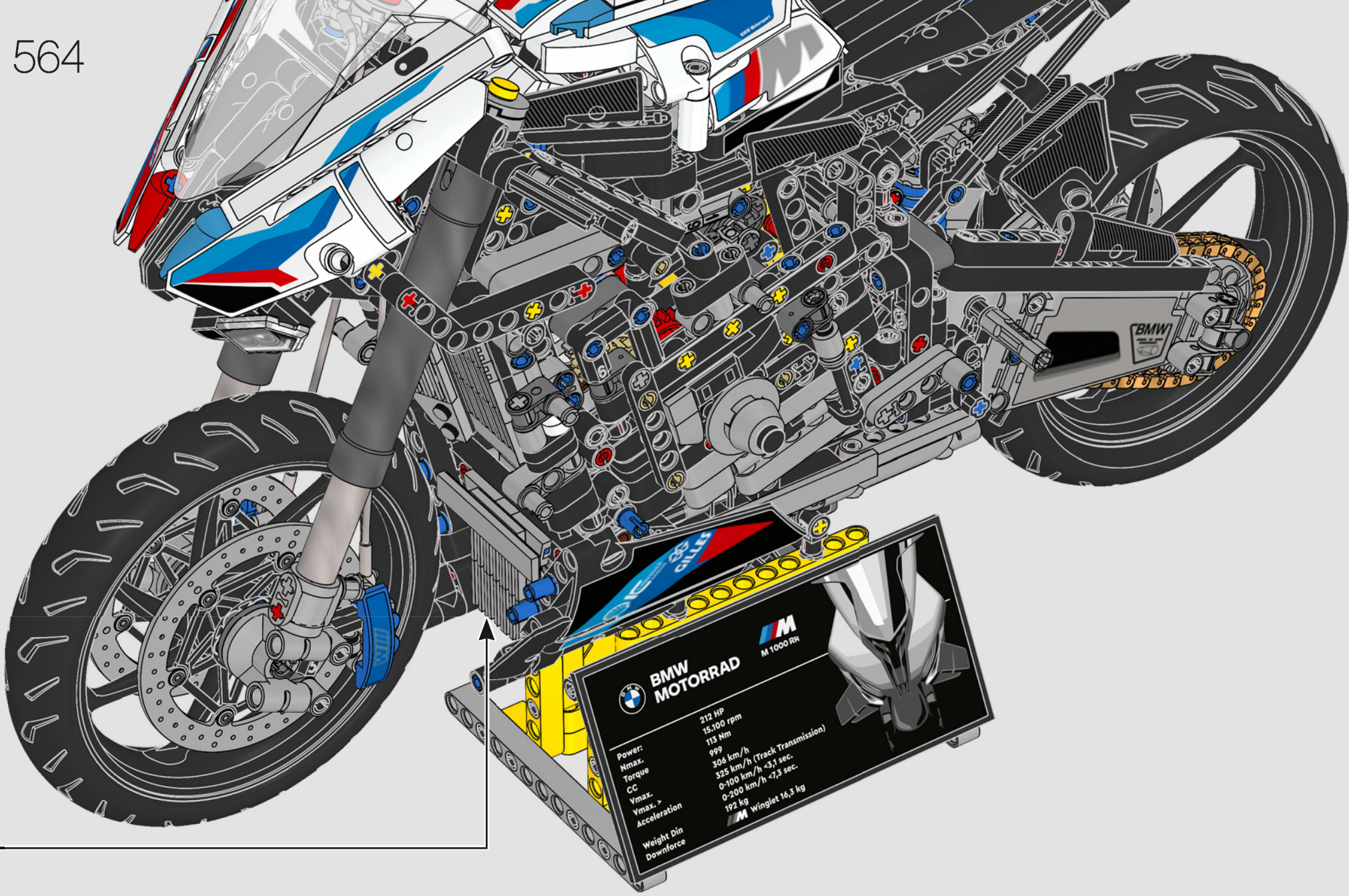

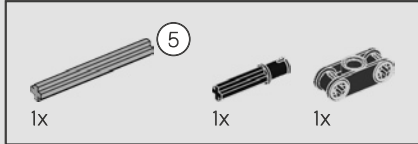
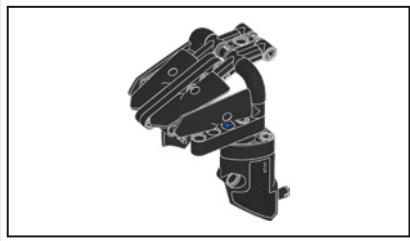

565

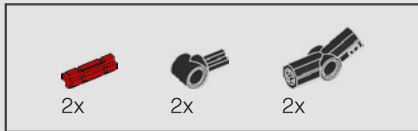
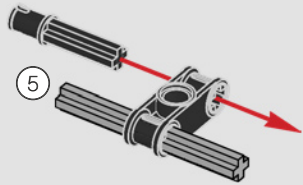

566

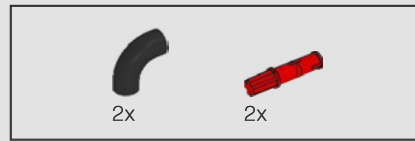
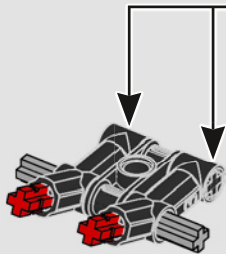
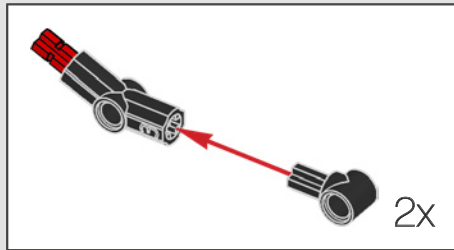

567

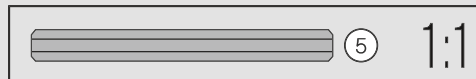
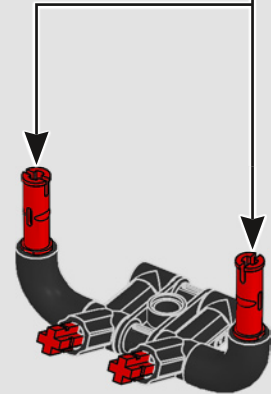
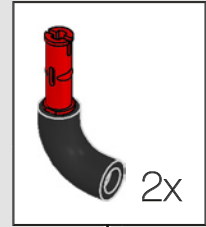

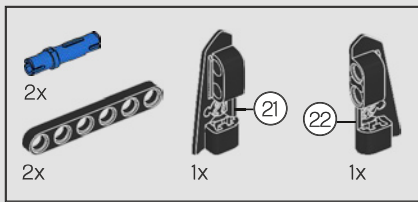

568

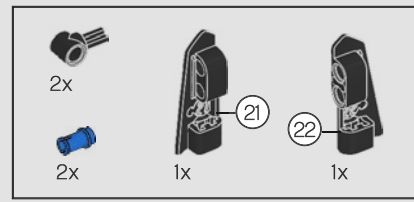
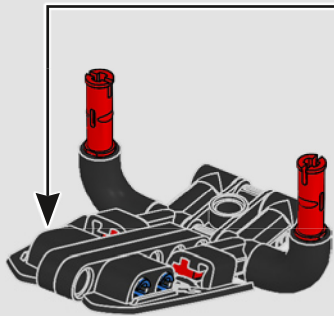
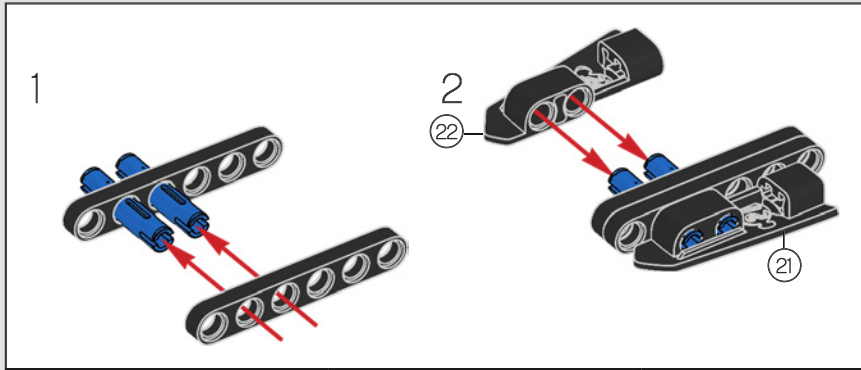
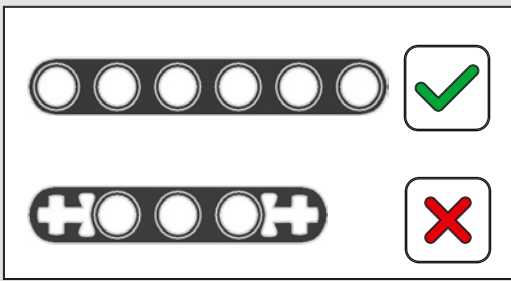

569

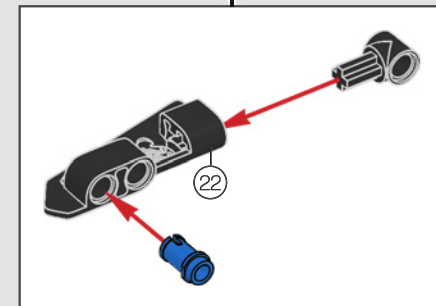
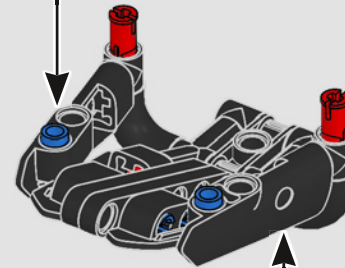
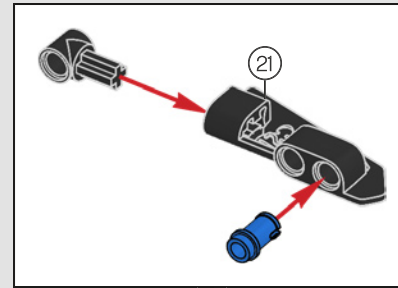

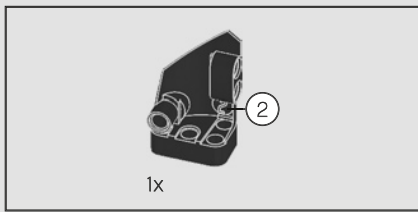

570

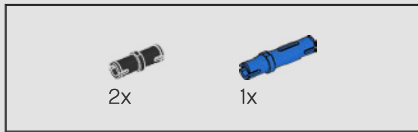
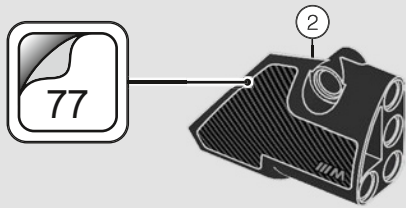

571

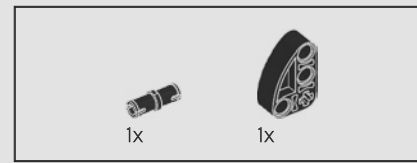
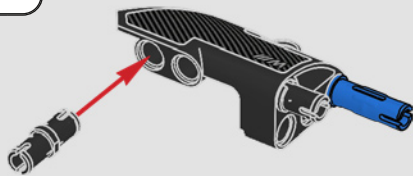

572

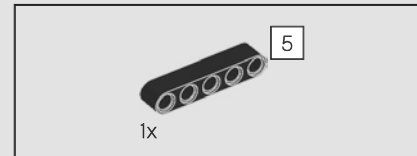
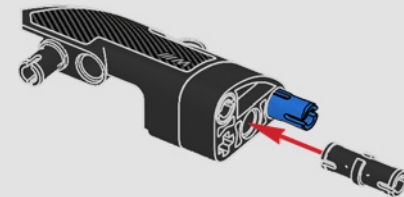

573

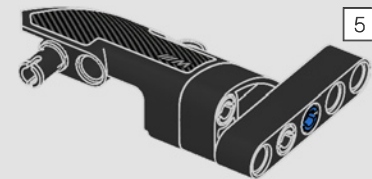

574

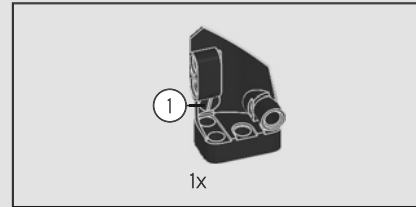
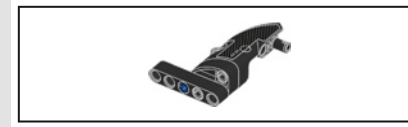
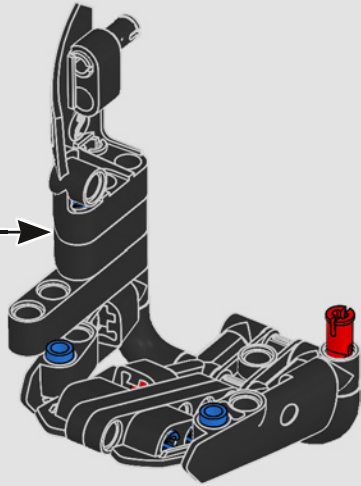

575

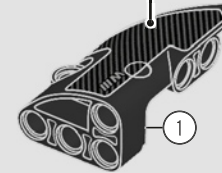

576

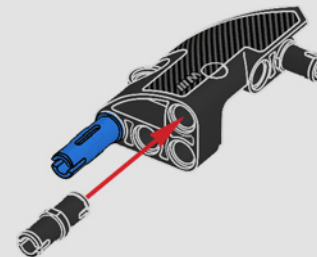

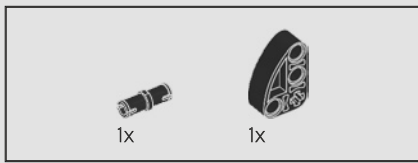

577

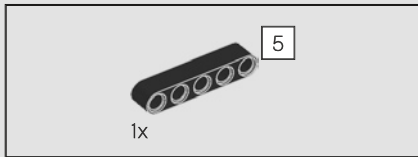
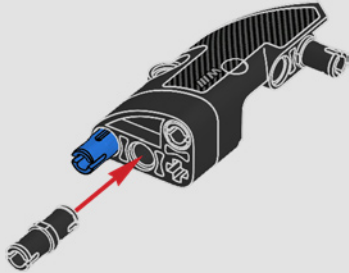

578

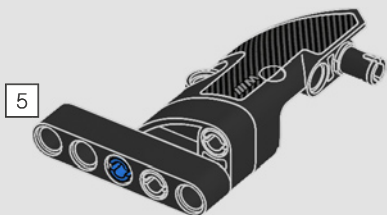

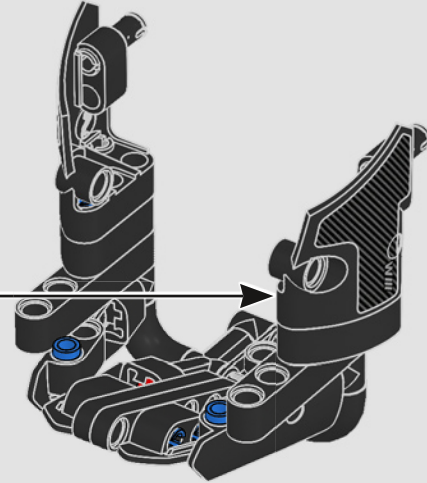

579

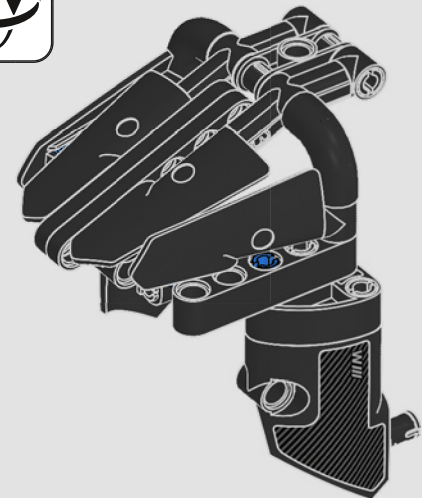
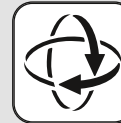

580

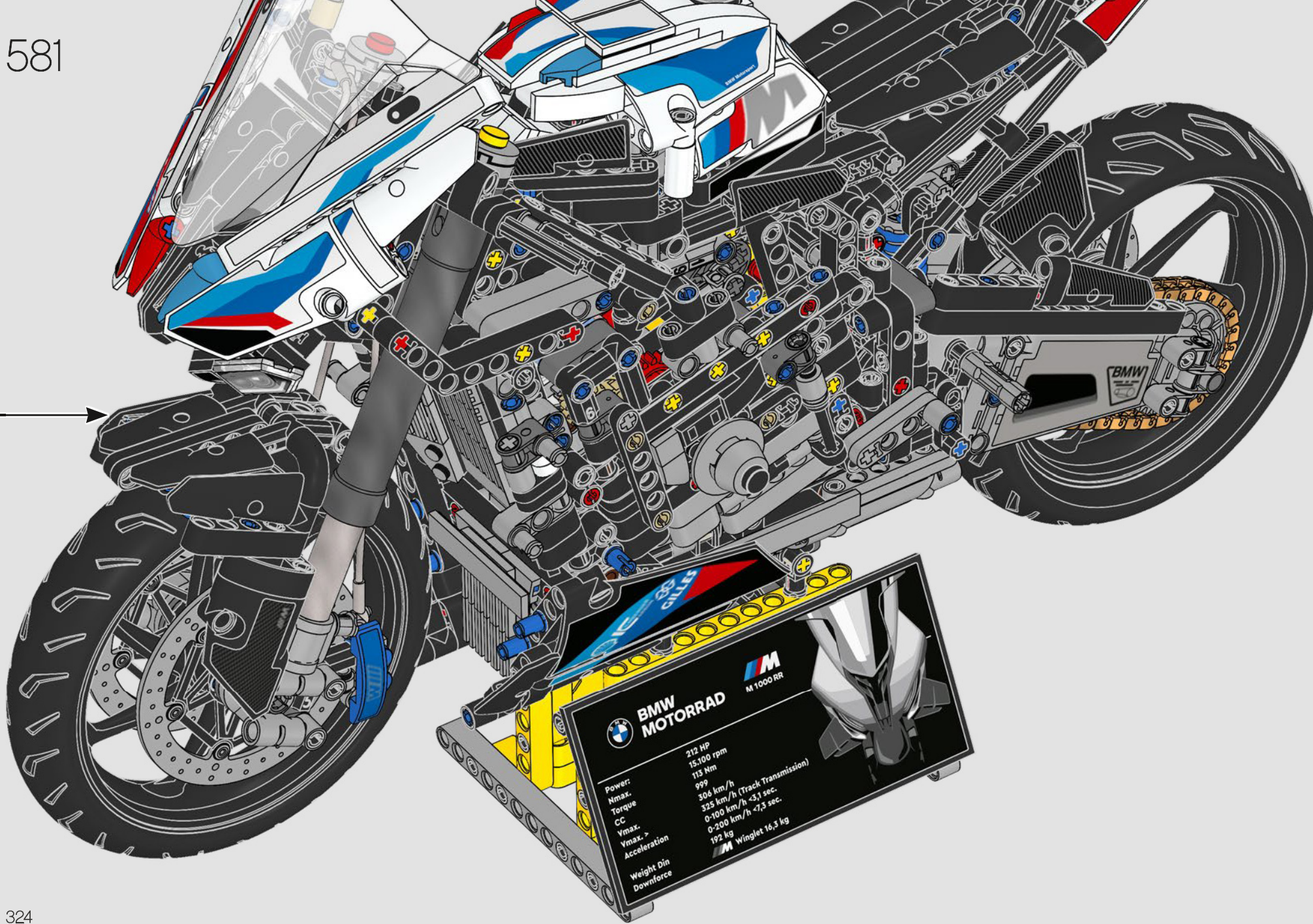



BMW MOTORRAD  M 1000 RR

Power:	212 HP
Nmax:	15,100 rpm
Torque:	118 Nm
CC:	999
Vmax:	306 km/h
Vmax. >	325 km/h (Track Transmission)
Acceleration	0-100 km/h < 3,1 sec.
	0-200 km/h < 7,3 sec.
Weight Din	192 kg
Downforce	 Winglet 16,3 kg

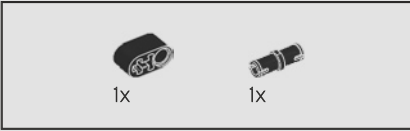
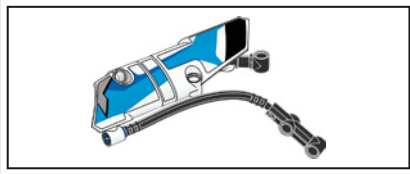

582

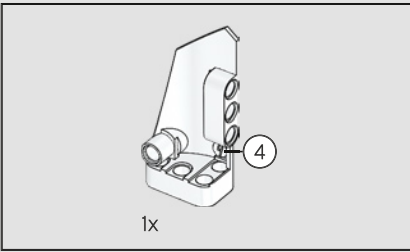
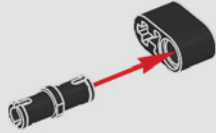

583

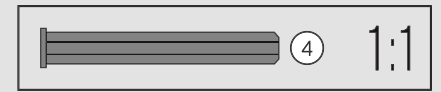
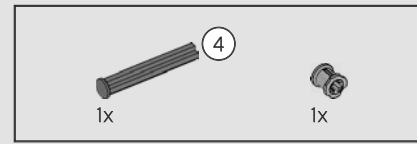
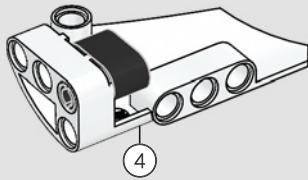

584

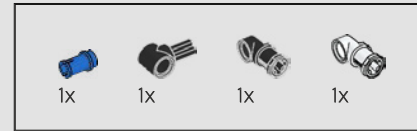
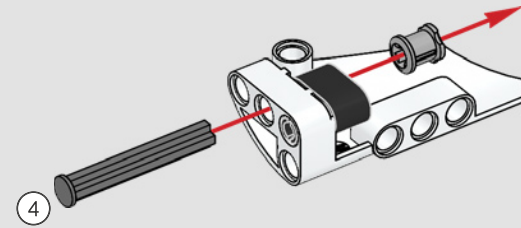

585

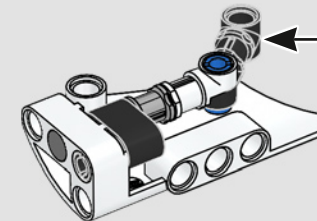
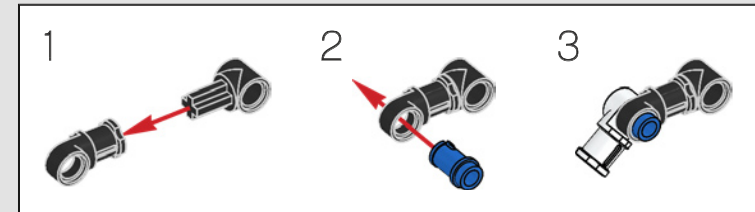

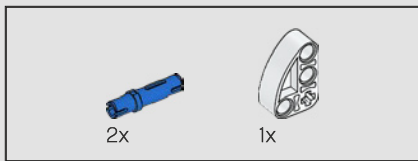

586

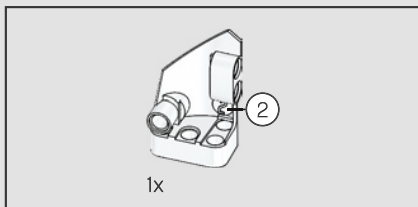
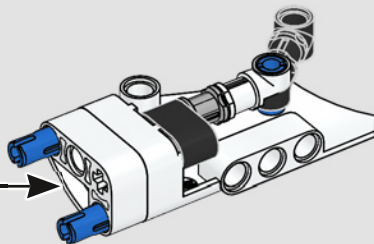
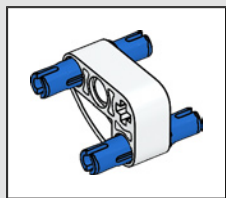

587

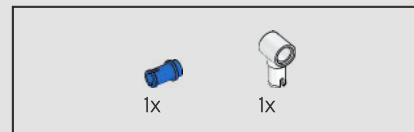
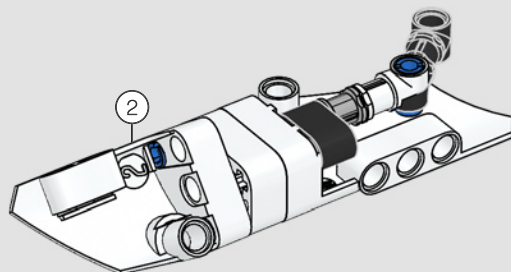

588

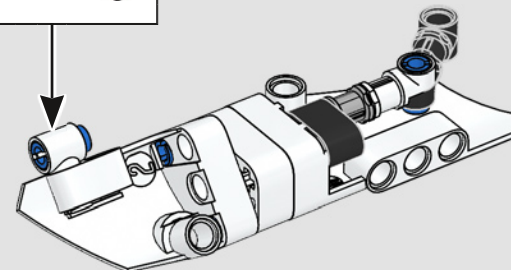
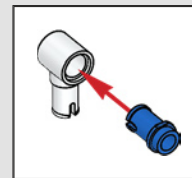

589

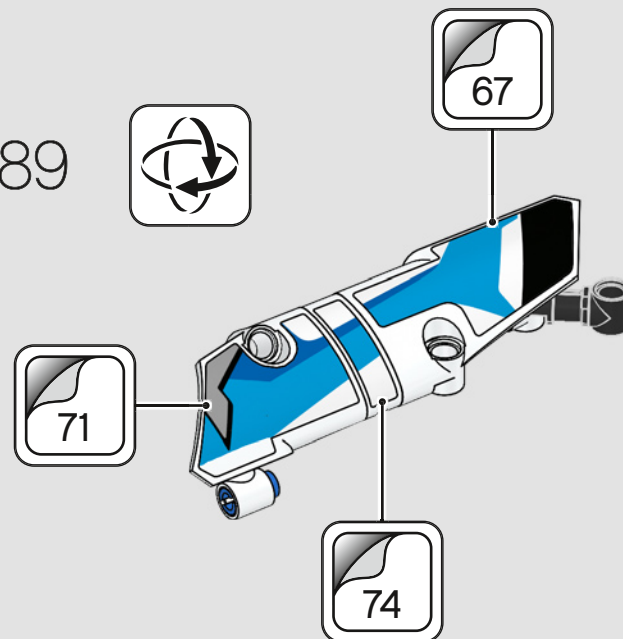

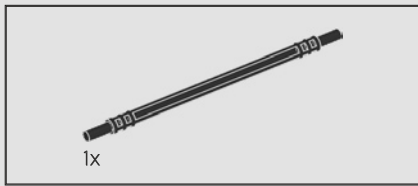

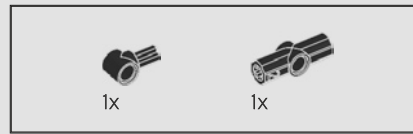
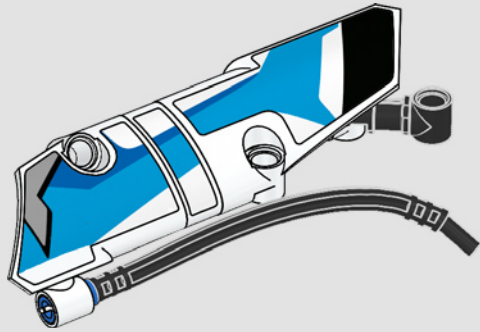

590

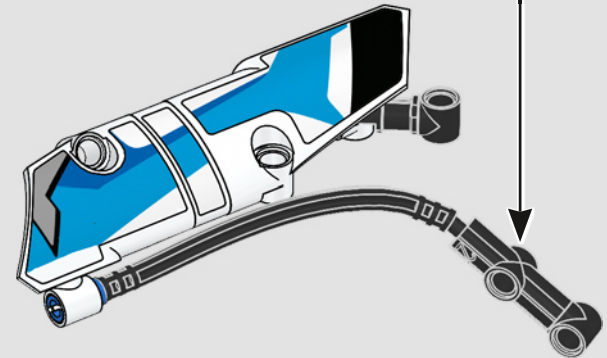
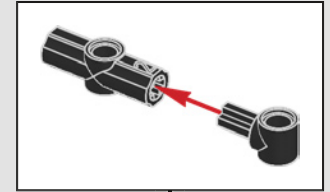

591

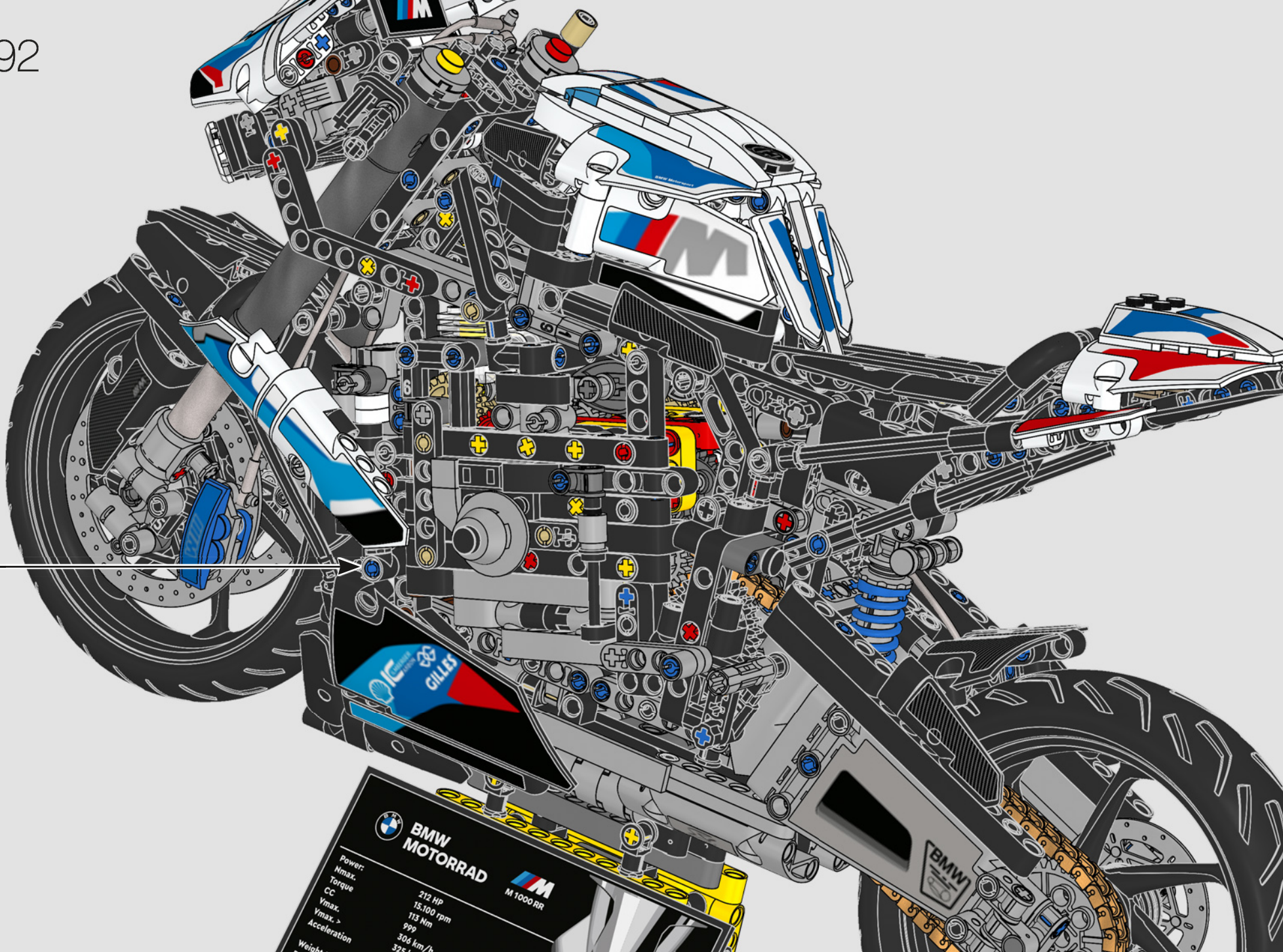



BMW
MOTORRAD

M 1000 RR

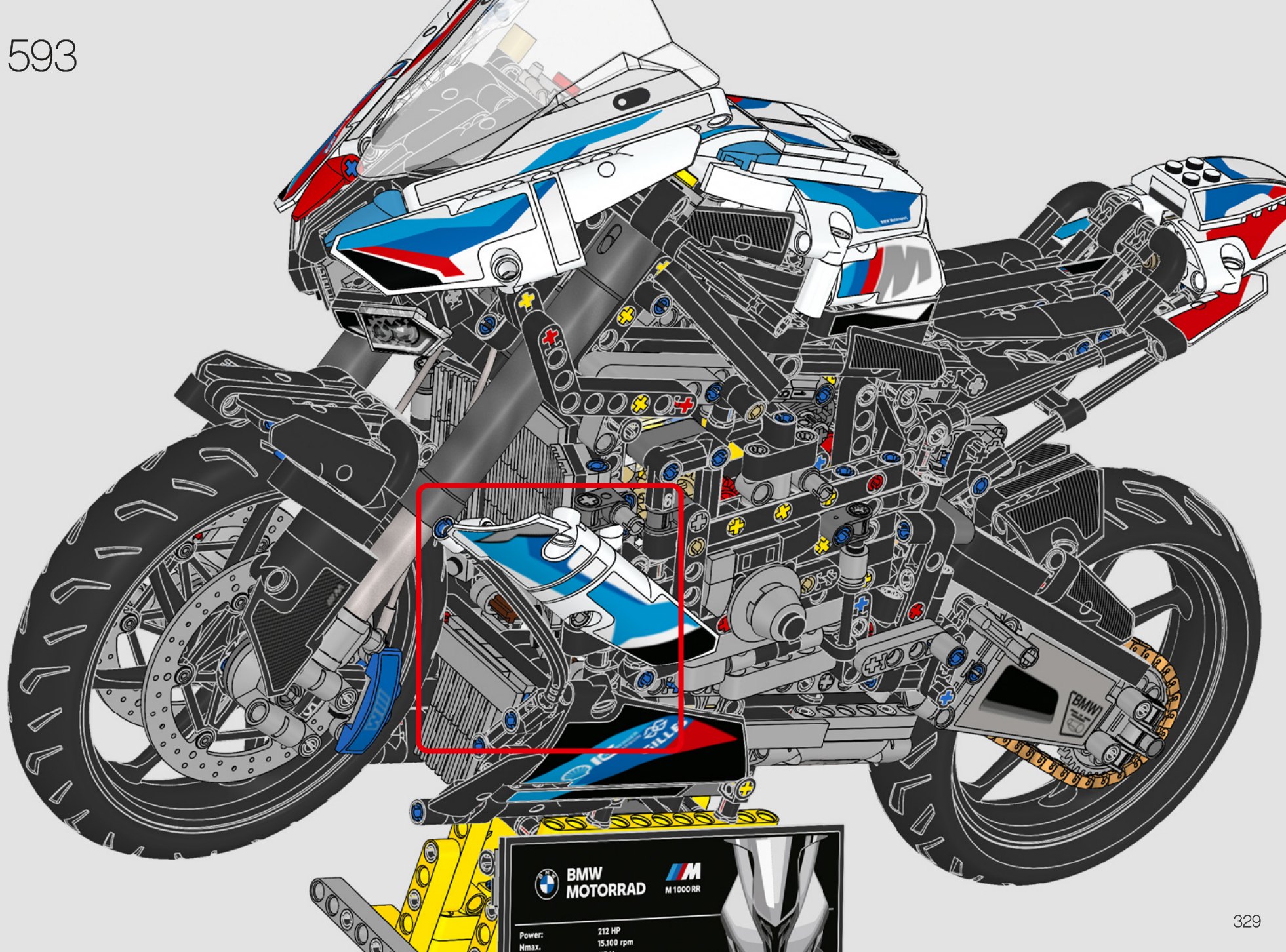
Power:	212 HP
Mmax.	15,100 rpm
Torque	113 Nm
CC	999
Vmax.	306 km/h
Vmax. >	328 km/h
Acceleration	
Weight	



BMW
MOTORRAD

M
M 1000 RR

Power: 212 HP
Nmax. 15.100 rpm

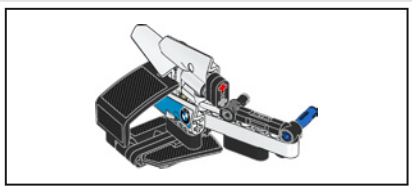

594

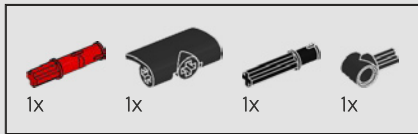
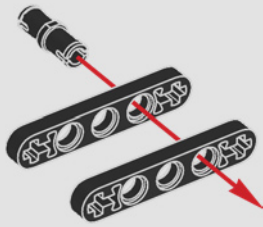

595

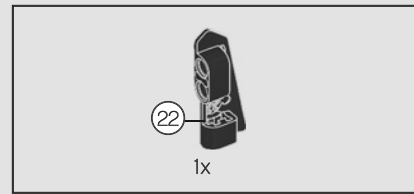
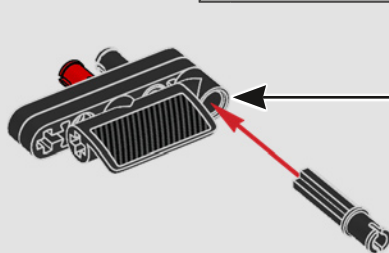
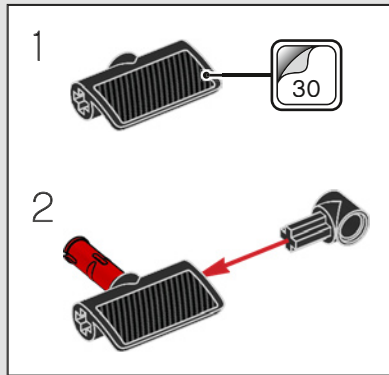

596

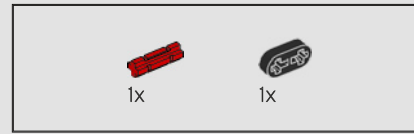
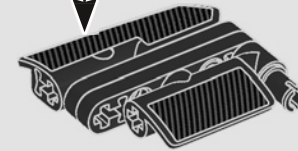
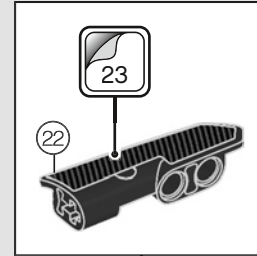

597

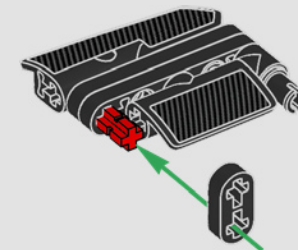

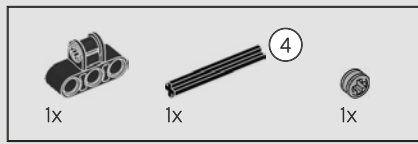

598

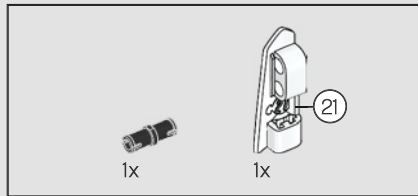
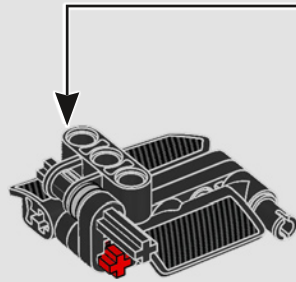
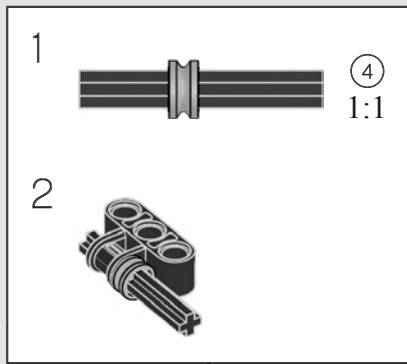

599

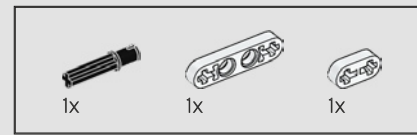
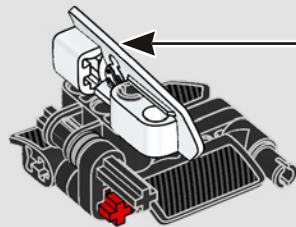
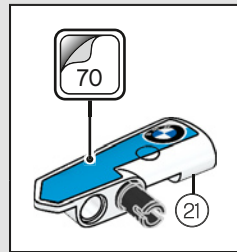

600

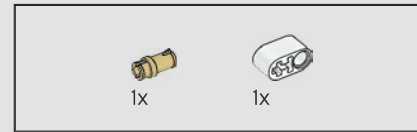
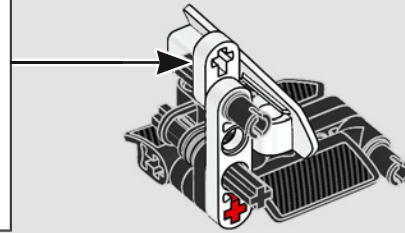
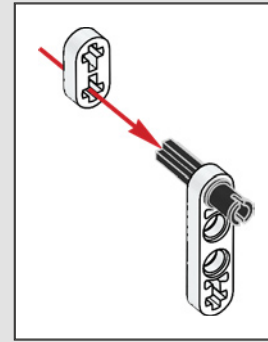

601

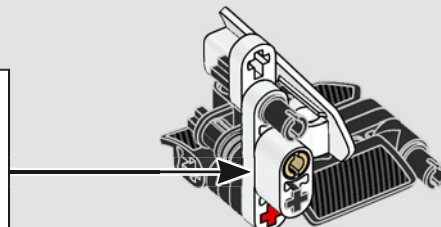
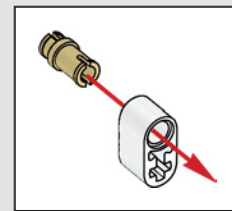

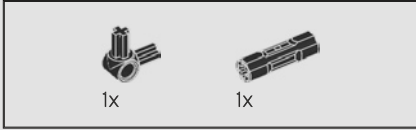
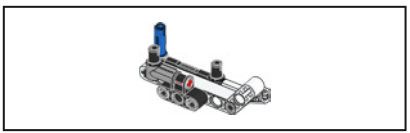

602

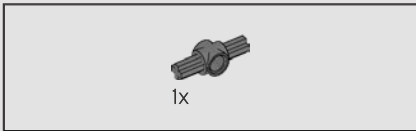
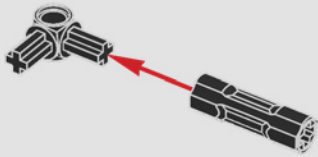

603

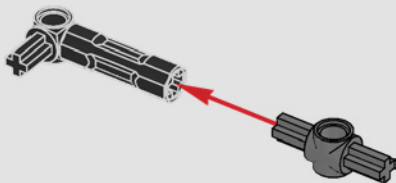

604

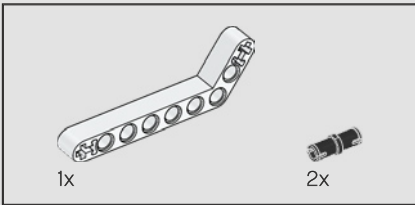
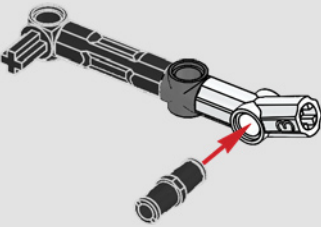

605

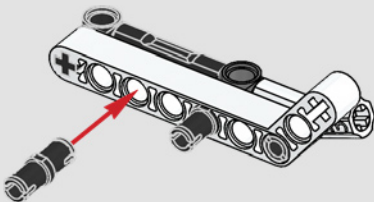

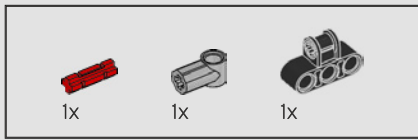

606

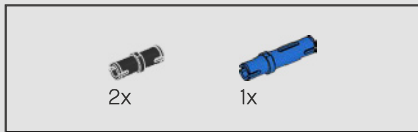
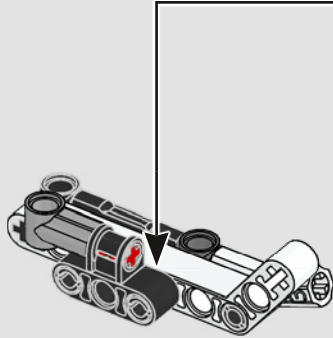
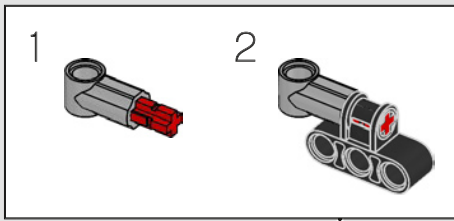

607

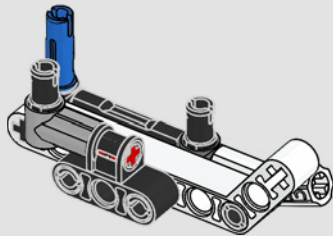

608

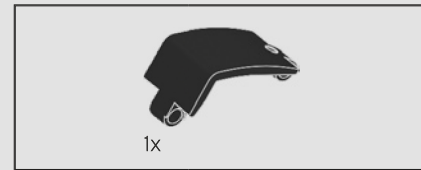
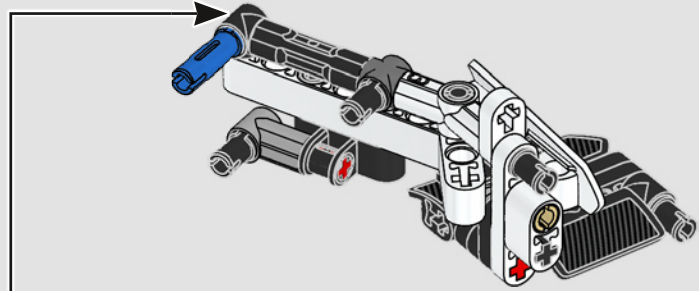

609

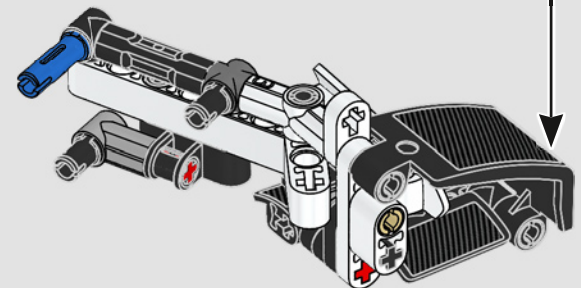
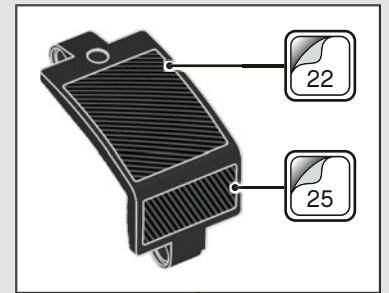

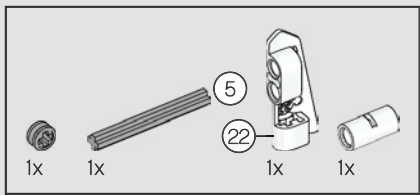

610

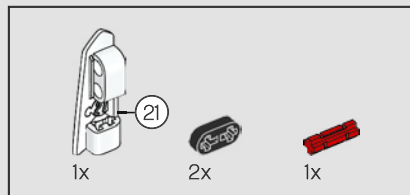
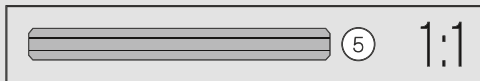
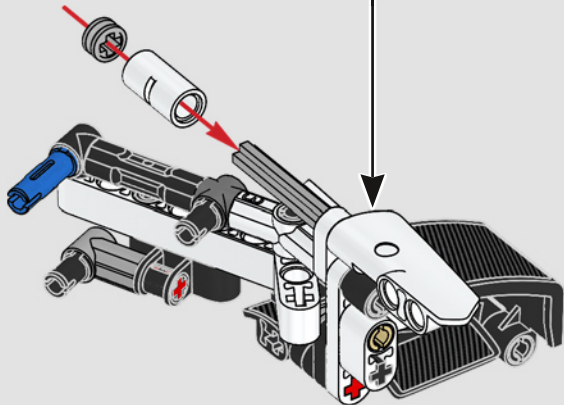
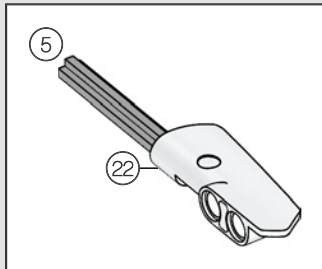

611

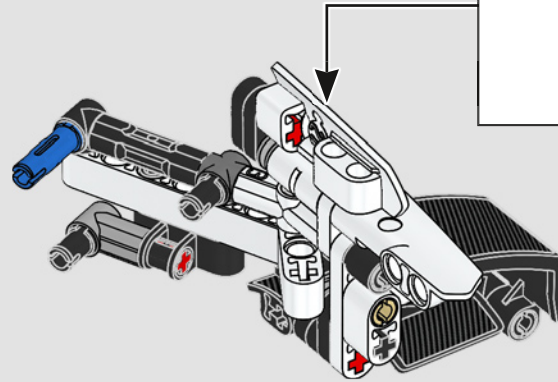
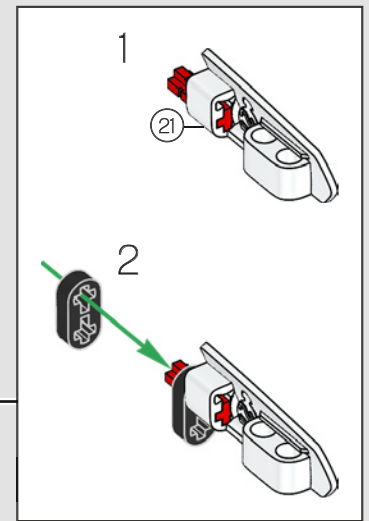

612

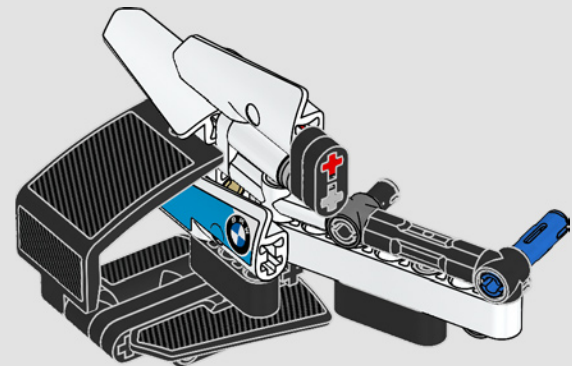

613

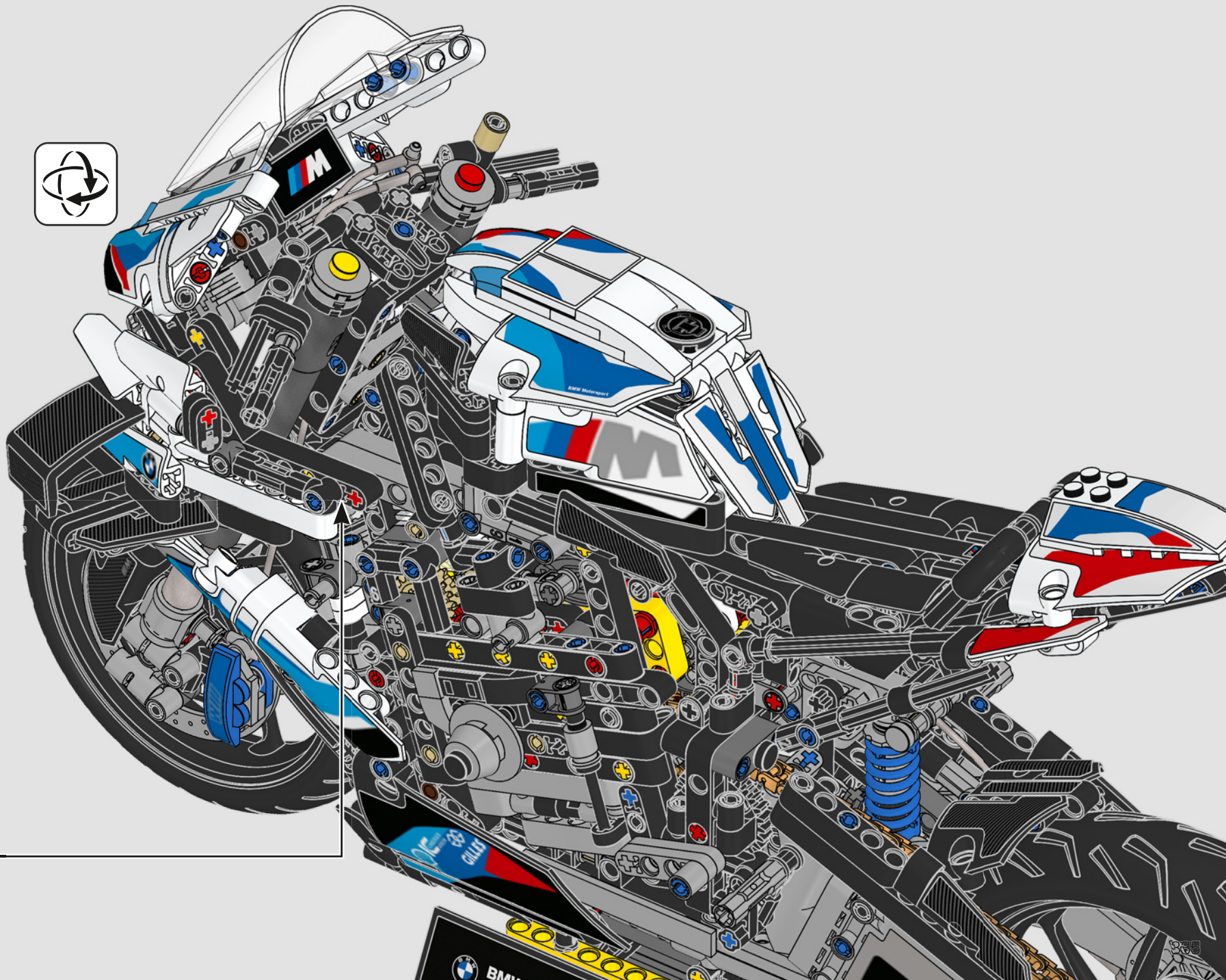

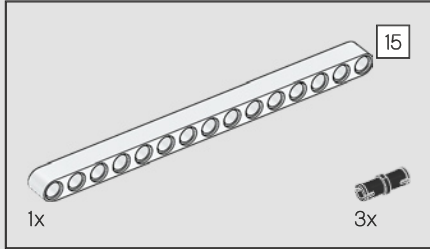
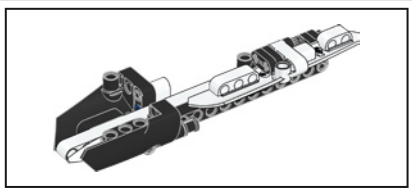

614

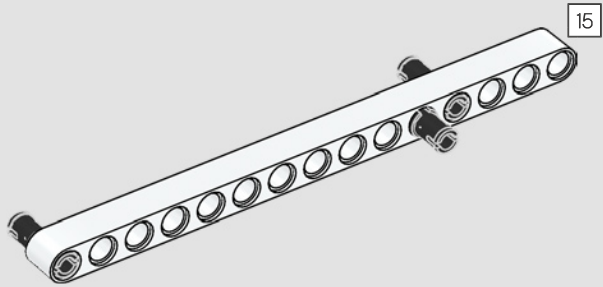

615

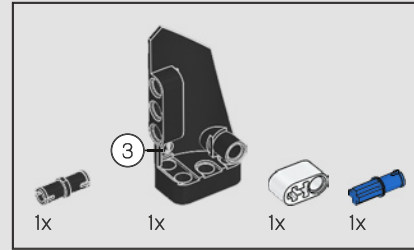
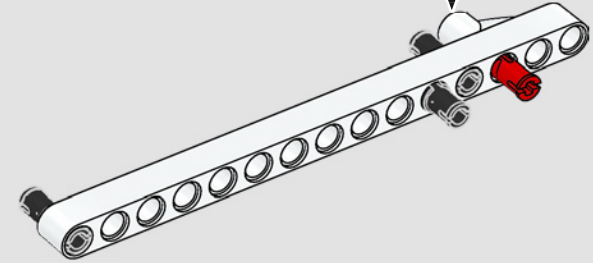
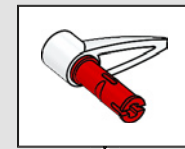

616

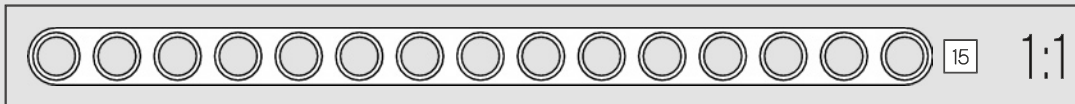
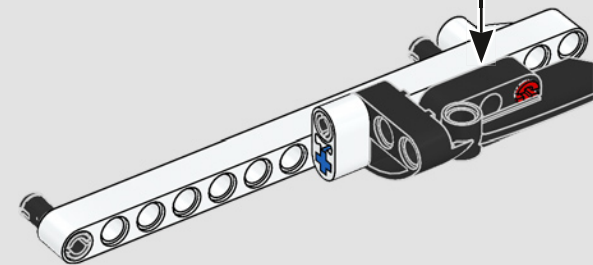
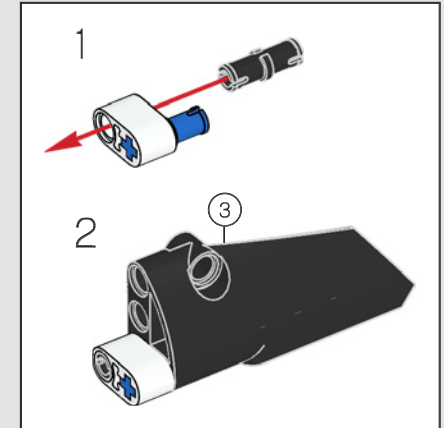

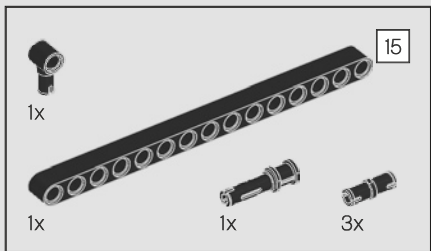

617

1

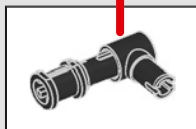
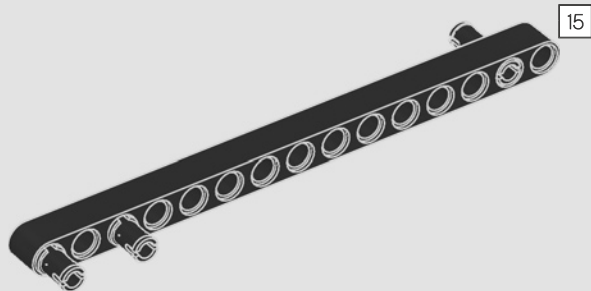

2

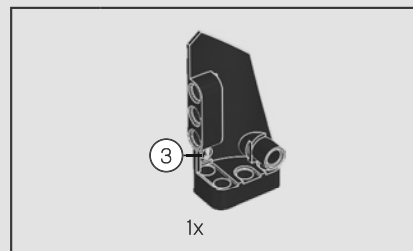
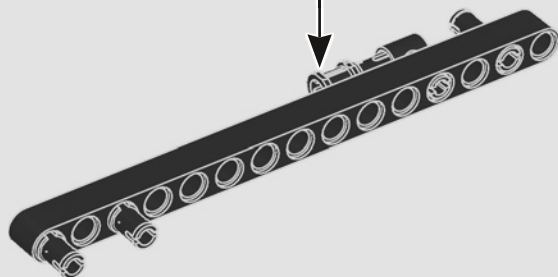

618

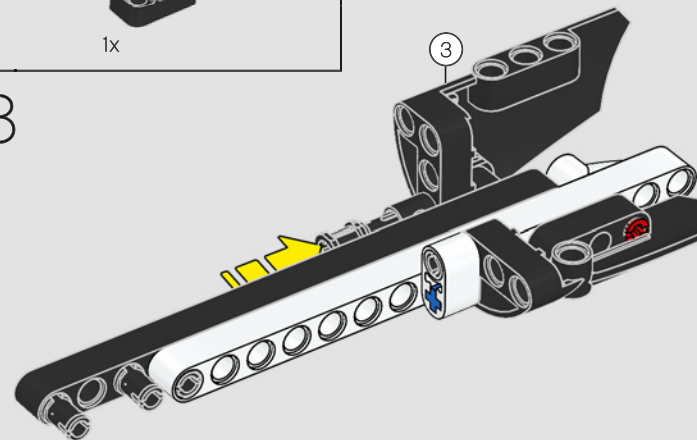

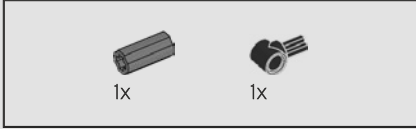
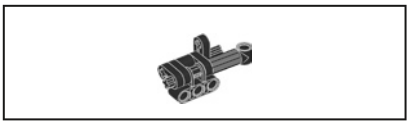

619

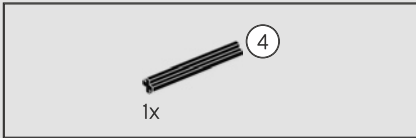
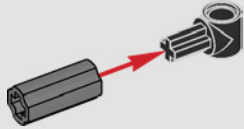

620

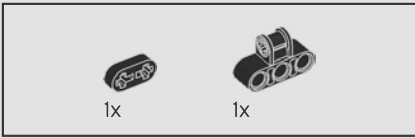
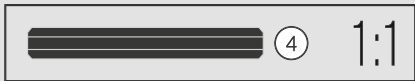
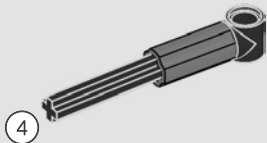

621

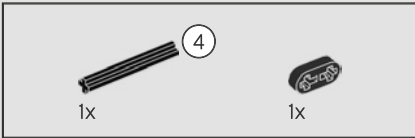
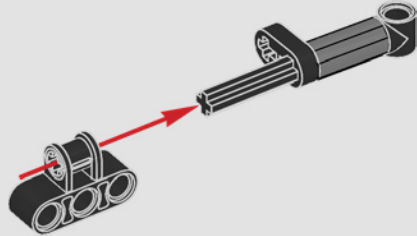

622

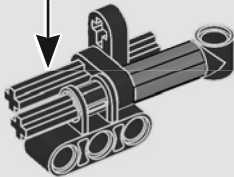
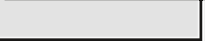



623

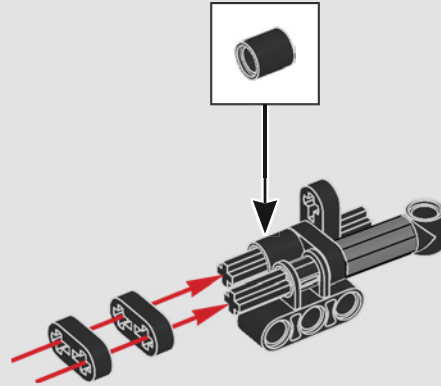

624

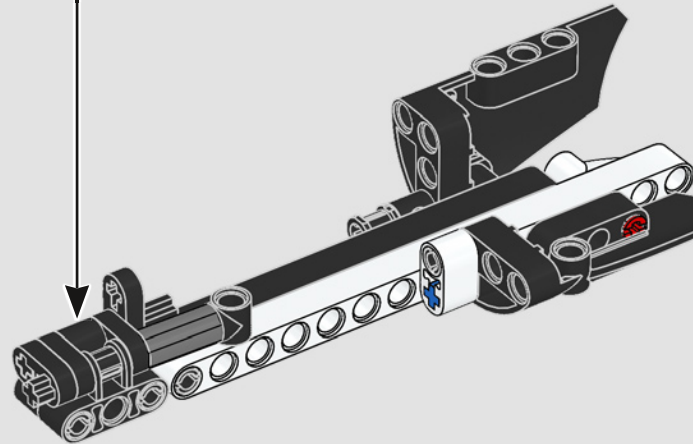

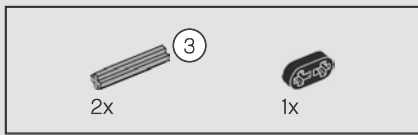

625

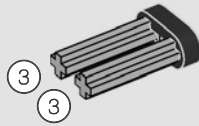
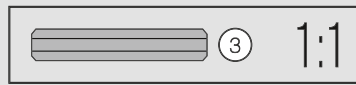

626

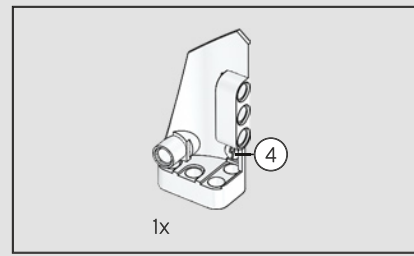
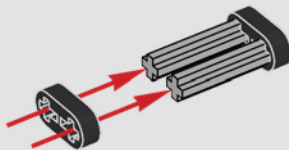

627

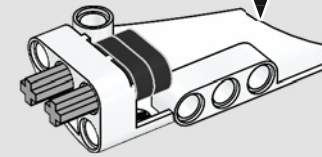
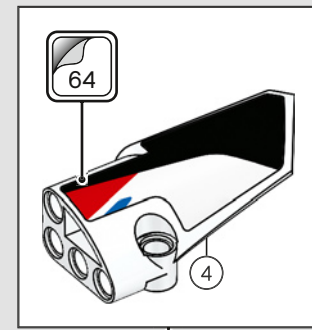

628

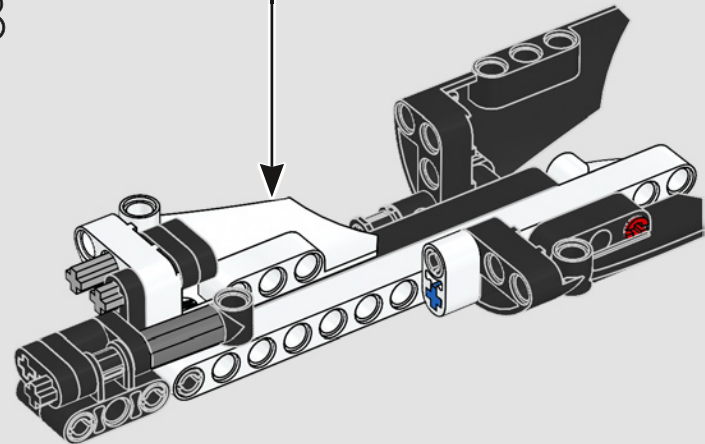

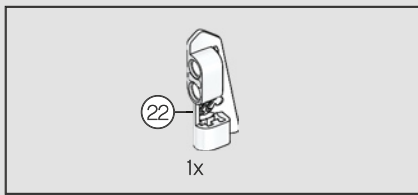

629

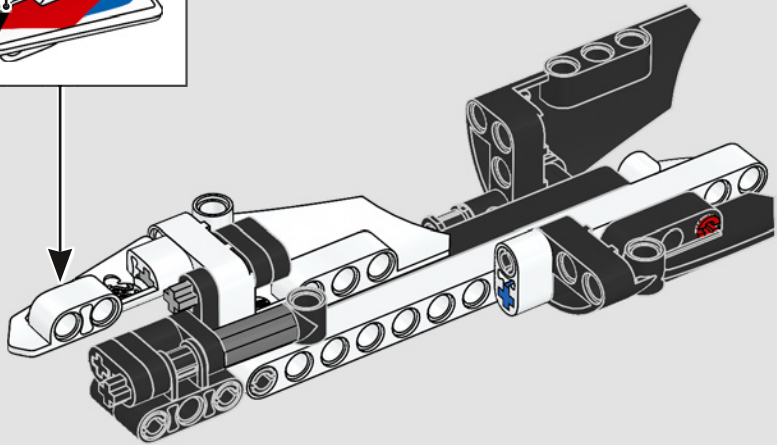
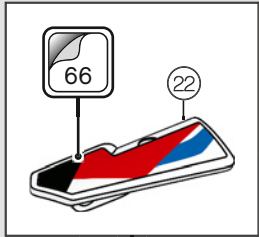

630

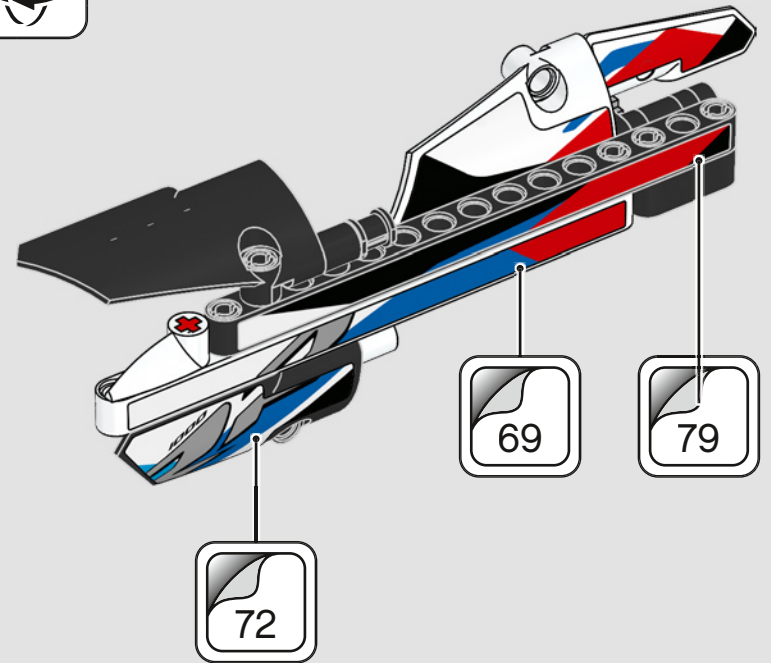

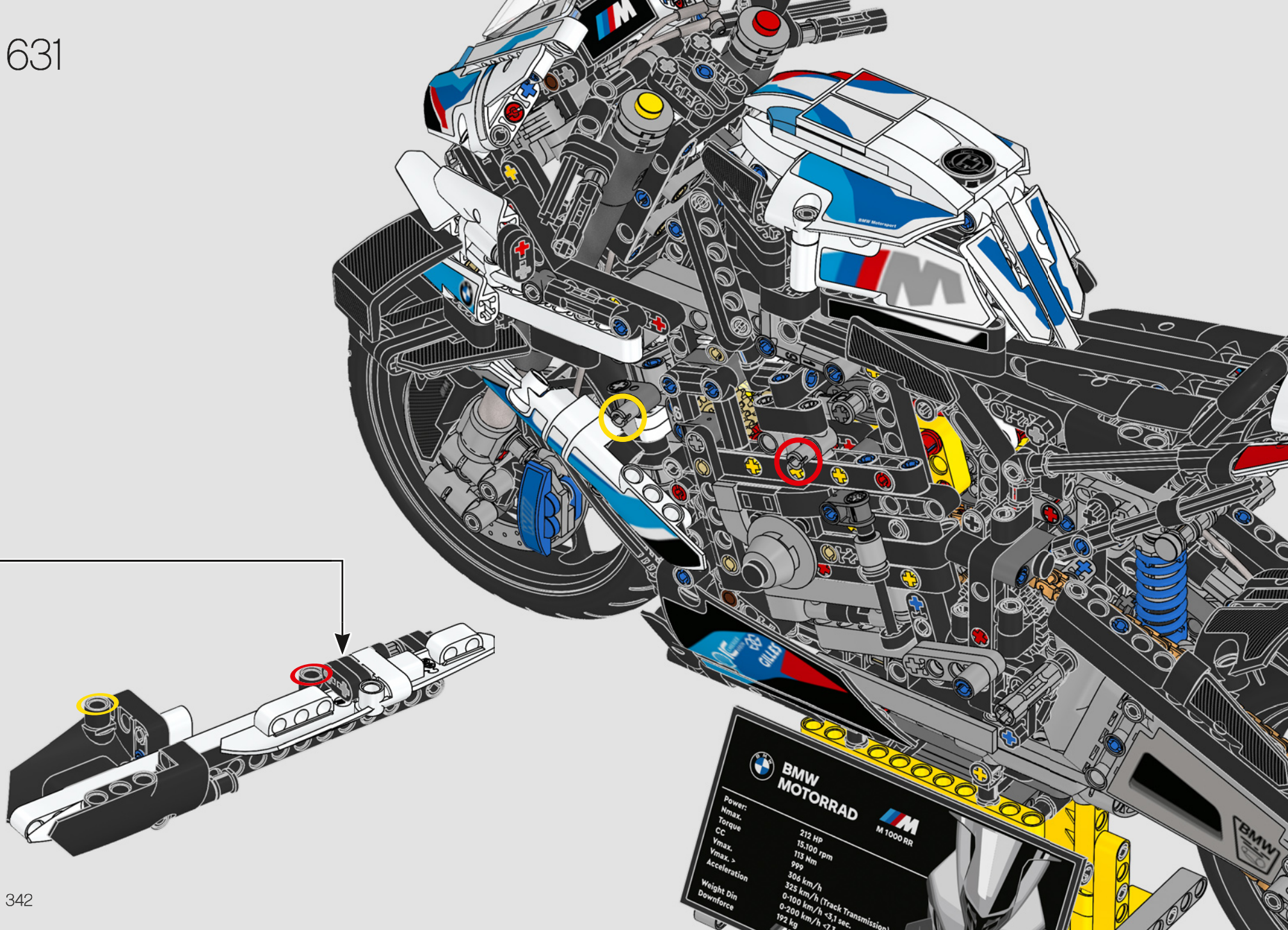

BMW MOTORRAD		M 1000 RR
Power:	212 hp	
Nmax:	15,100 rpm	
Torque	113 Nm	
CC	999	
Vmax:	306 km/h	
Vmax, >	325 km/h (Track Transmission)	
Acceleration	0-100 km/h < 3,1 sec.	
Weight Din	0-200 km/h < 7,3 sec.	
Downforce	192 kg	

632

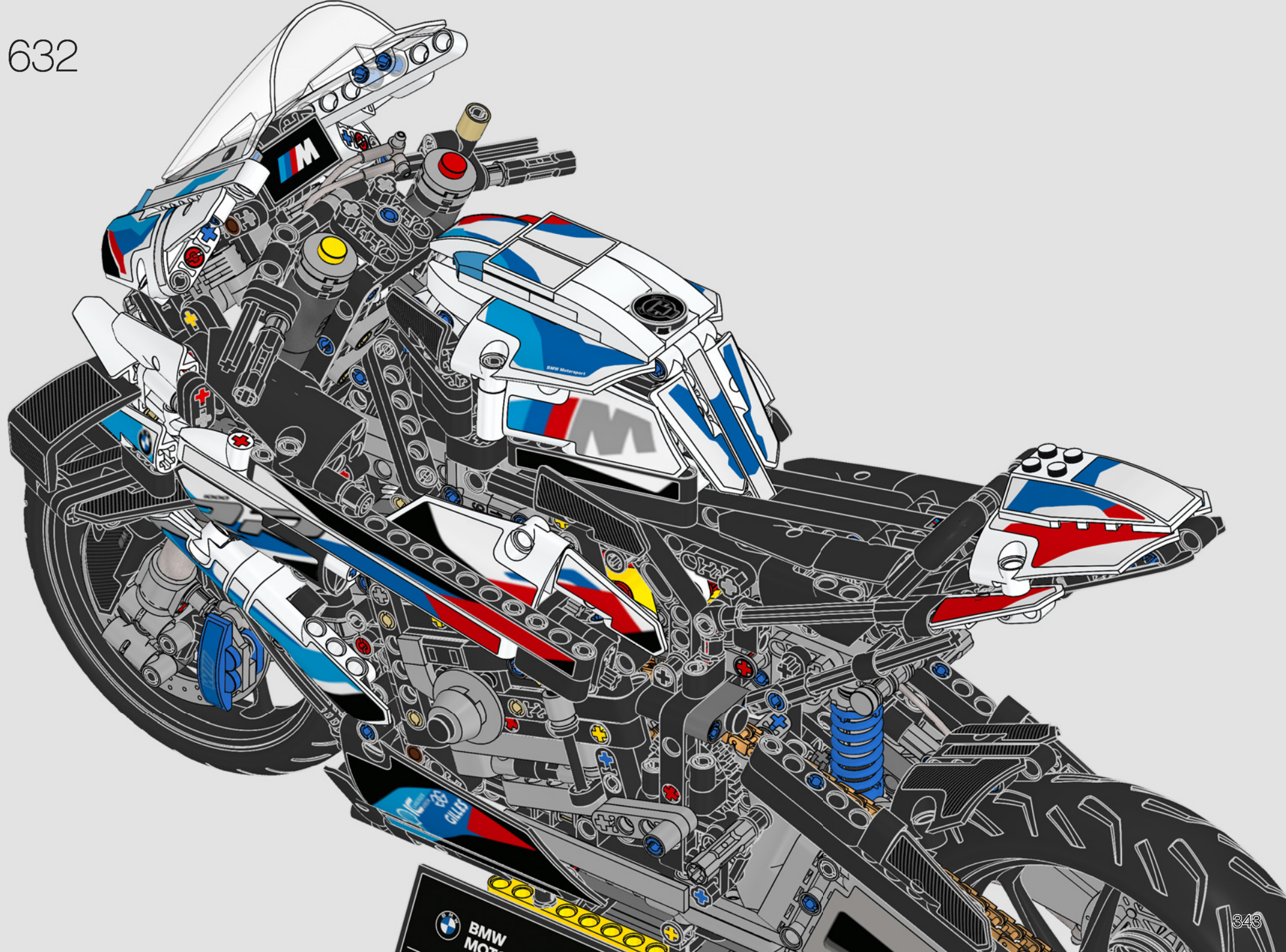

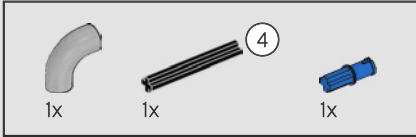
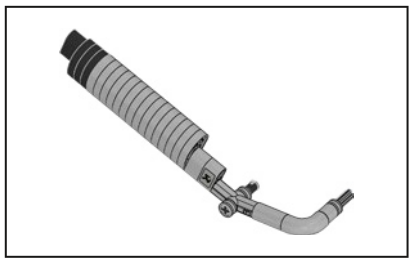

633

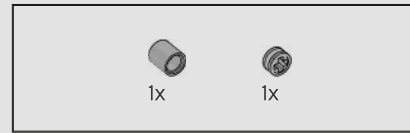
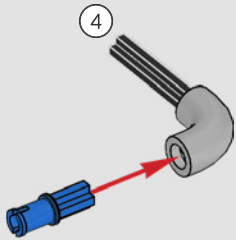

634

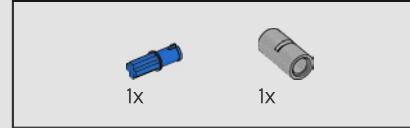
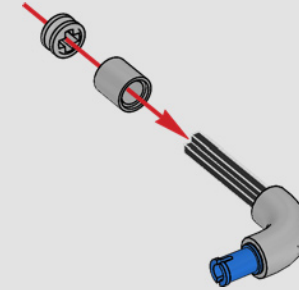

635

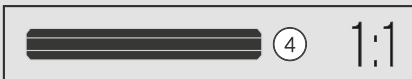
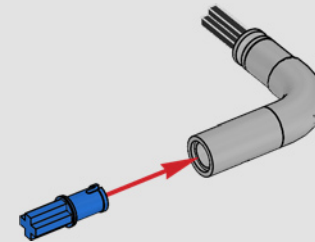

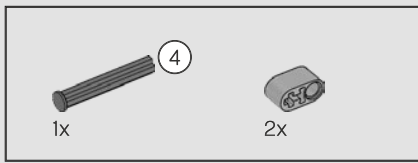

636

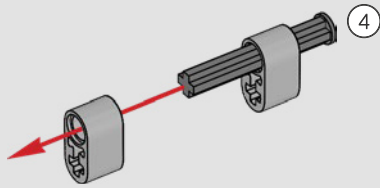

637

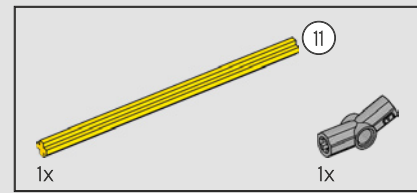
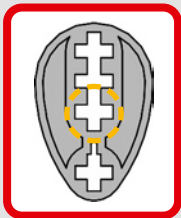
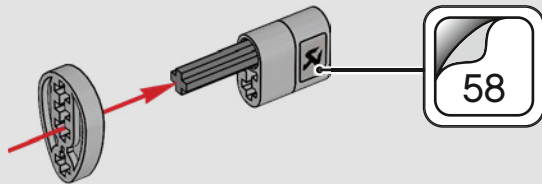

638

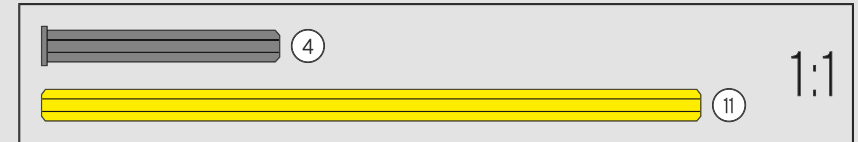
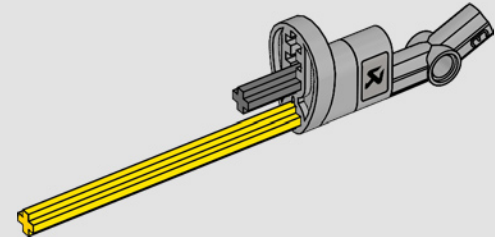
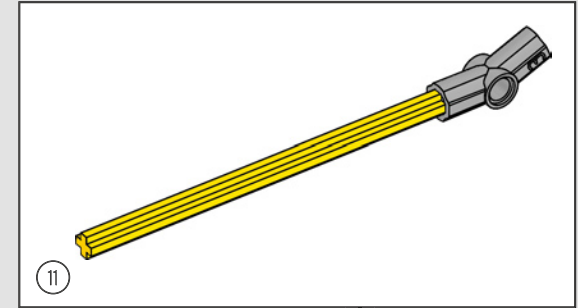



4x

639

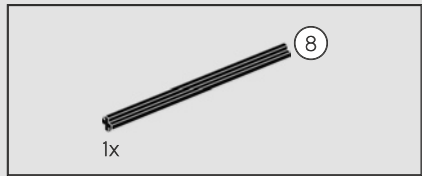
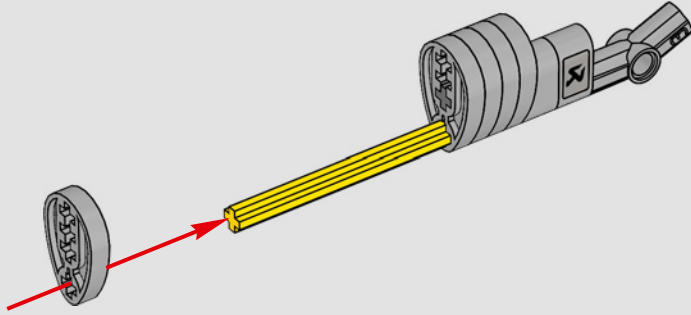

1x

640

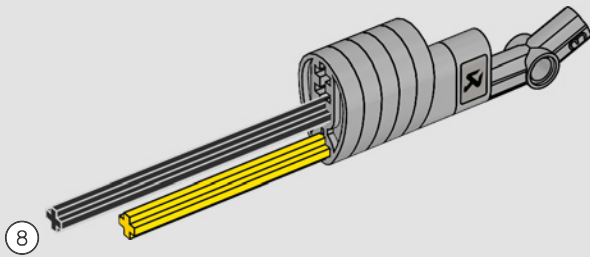

10x

641

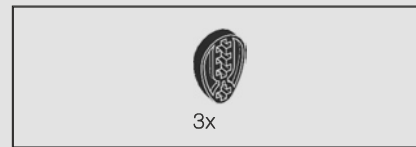
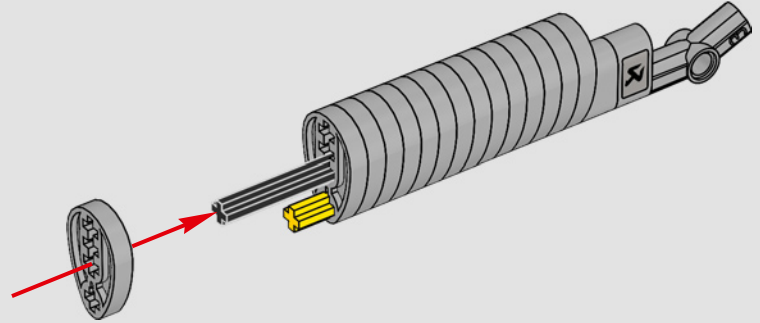

3x

642

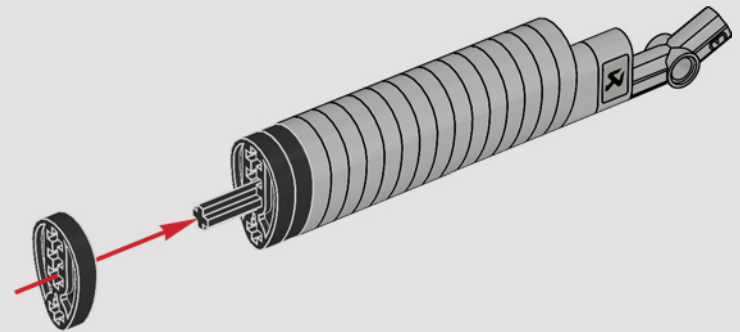

8

1:1

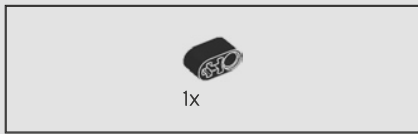

643

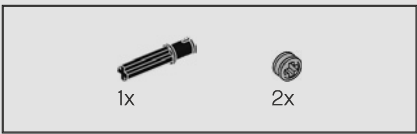
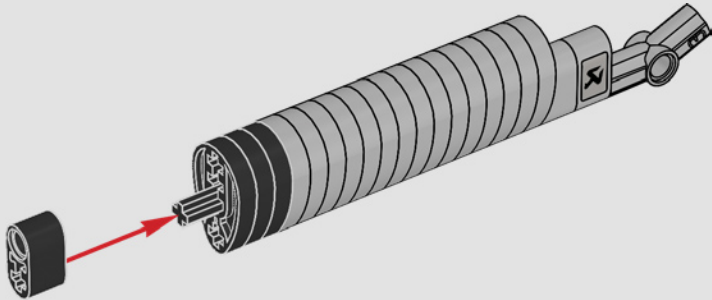

644

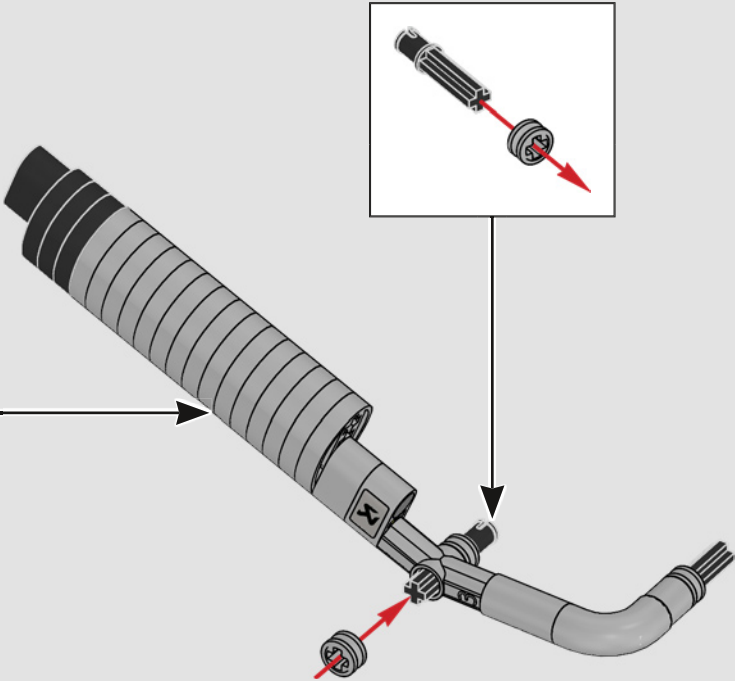

645

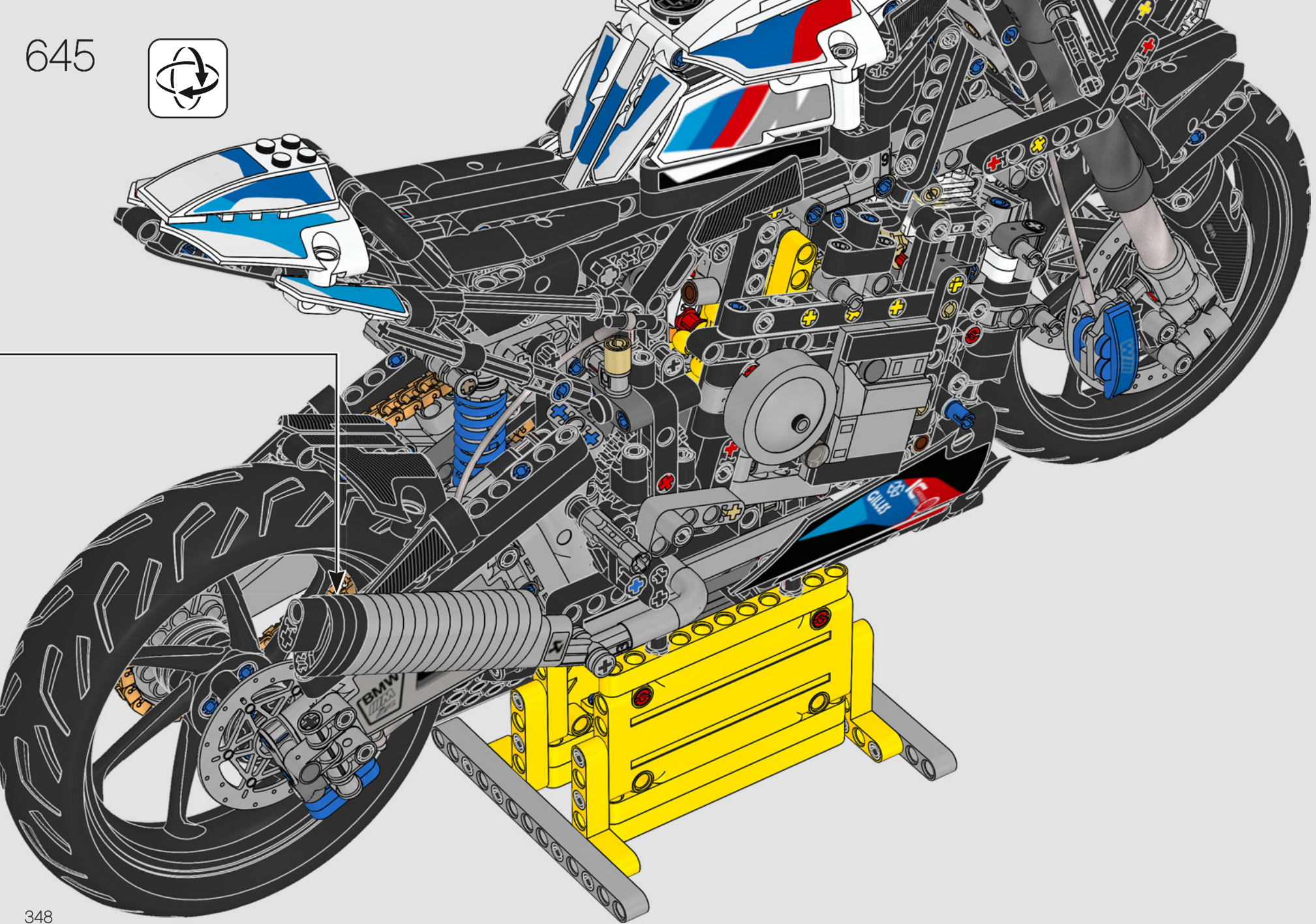

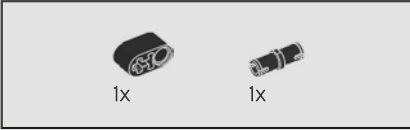
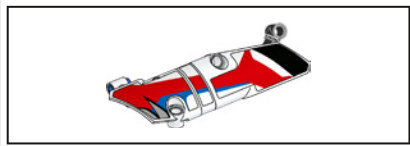

646

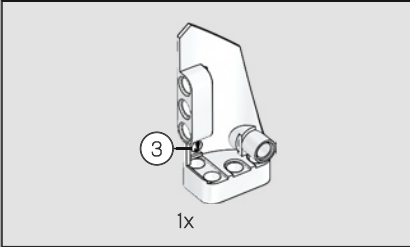
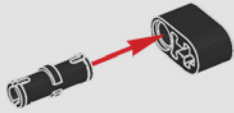

647

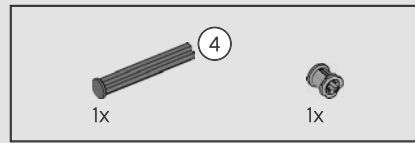
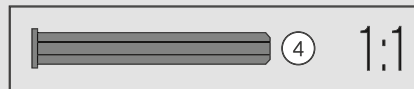
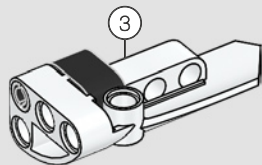

648

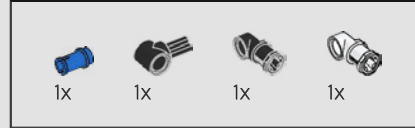
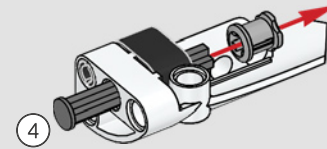

649

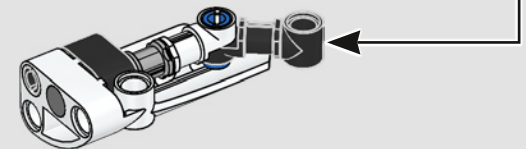
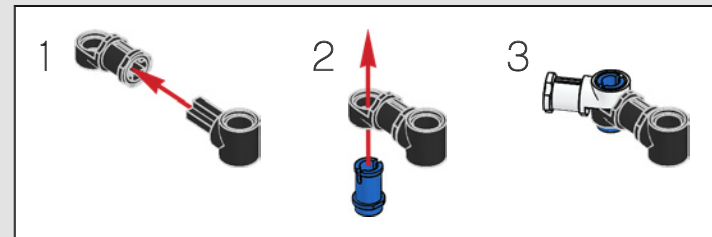

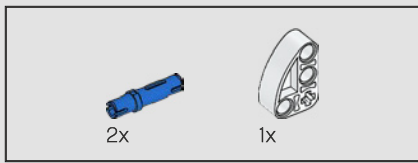

650

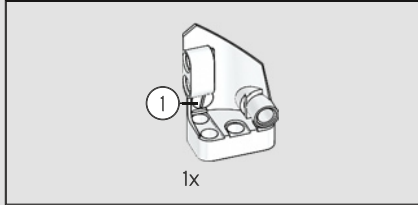
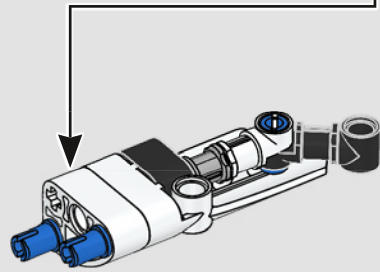
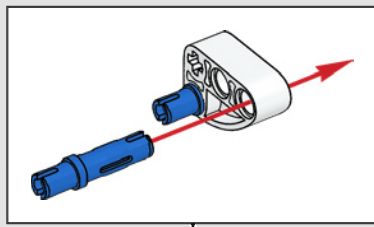

651

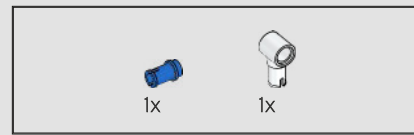
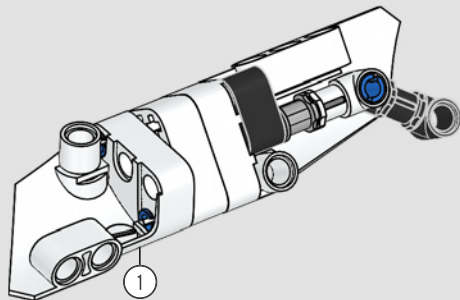

652

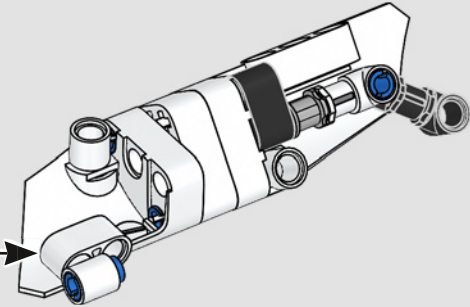
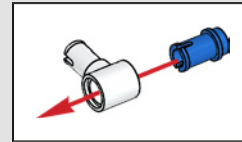

653

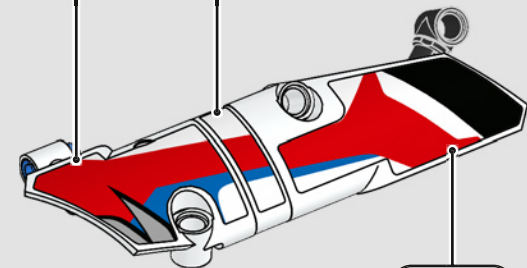

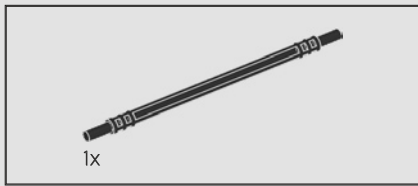

654

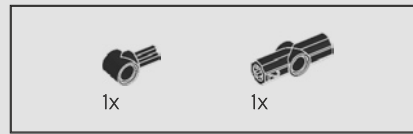
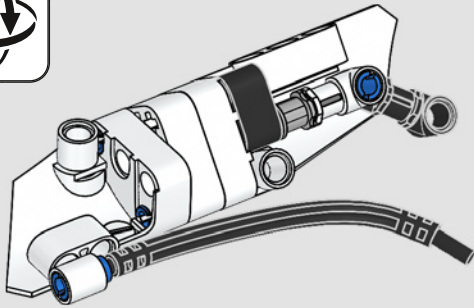

655

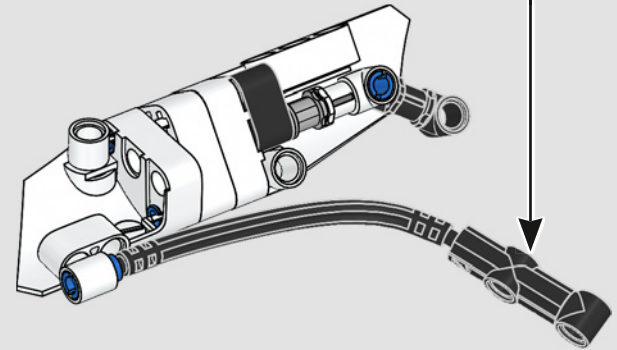
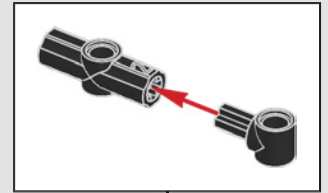

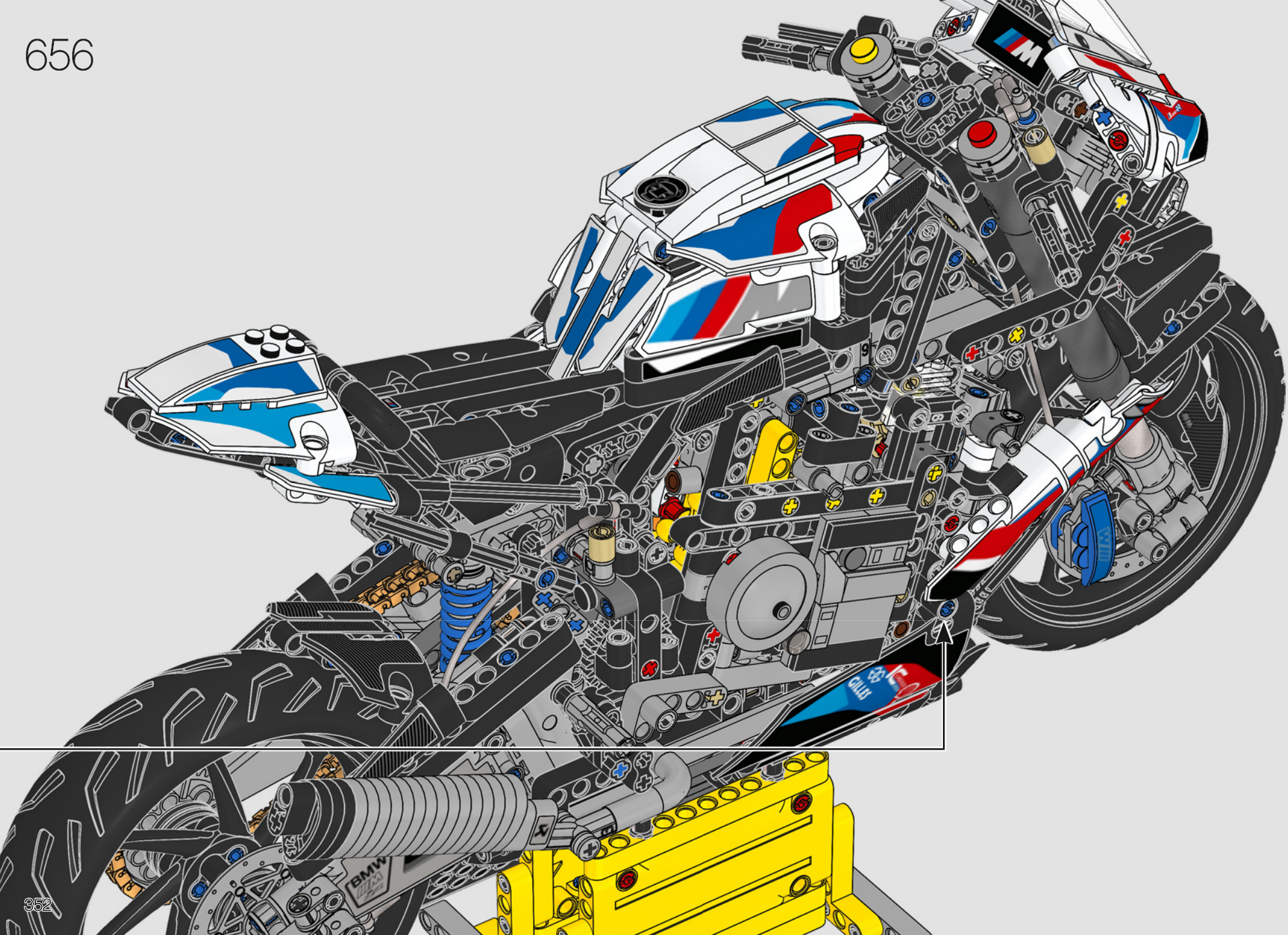

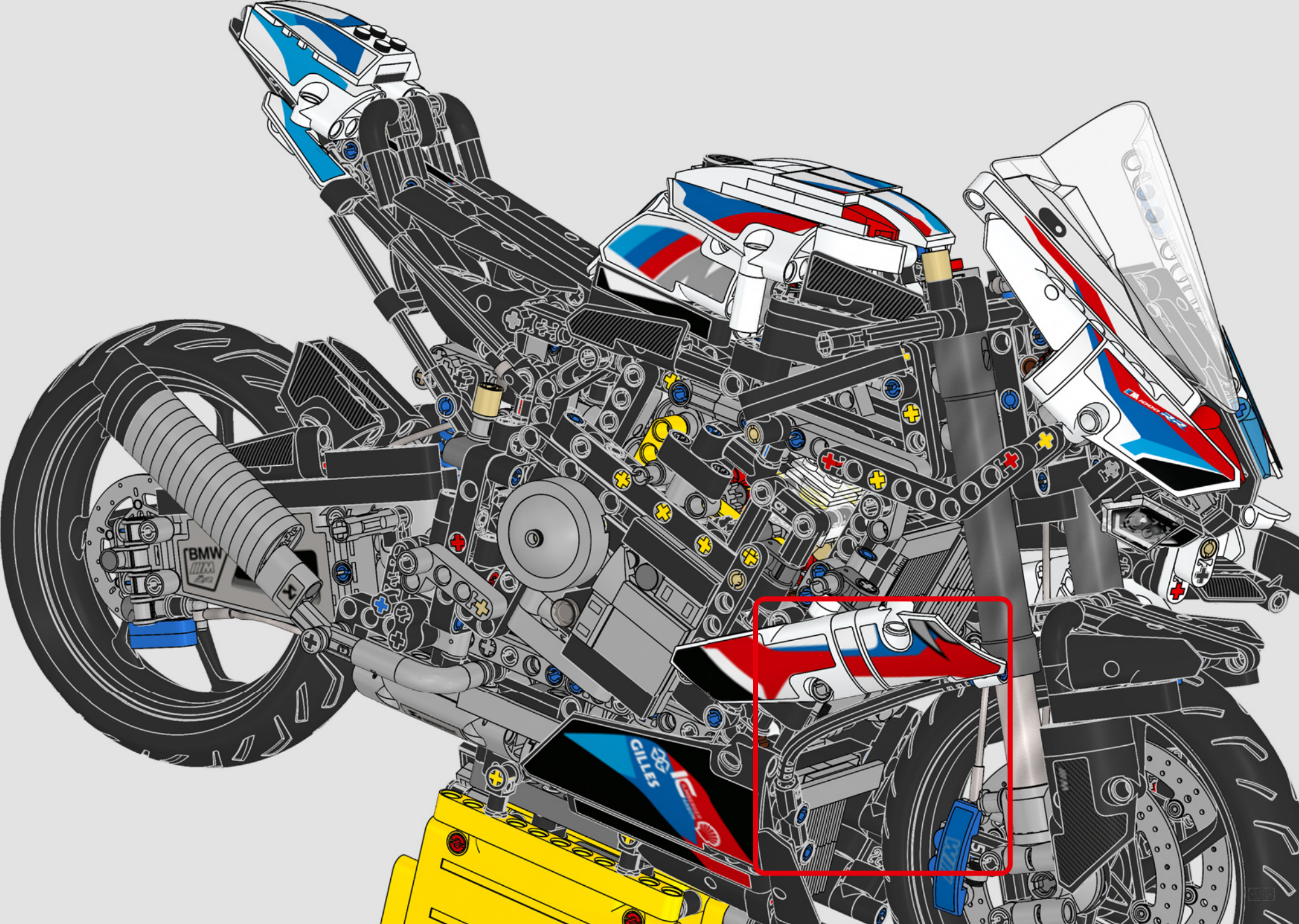

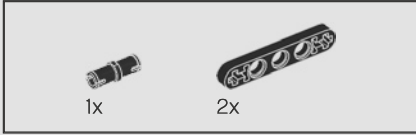
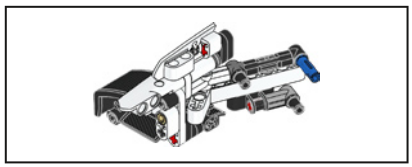

657

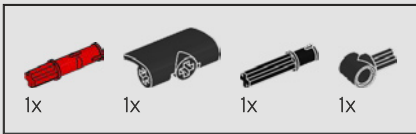
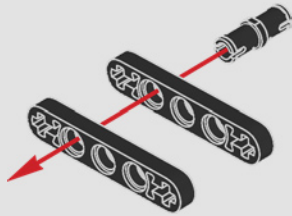

658

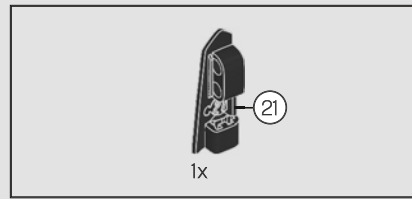
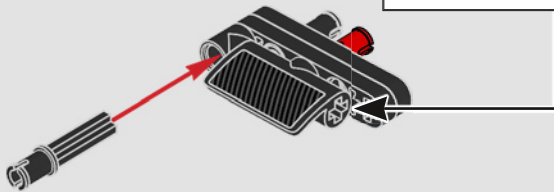
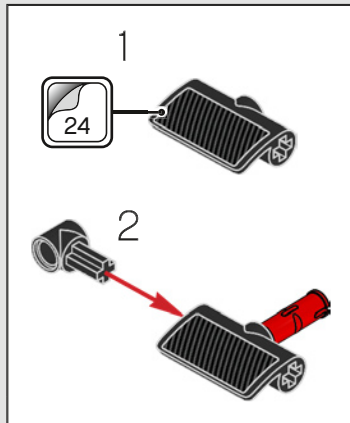

659

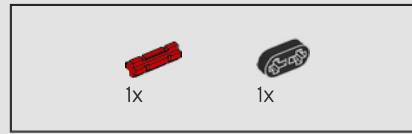
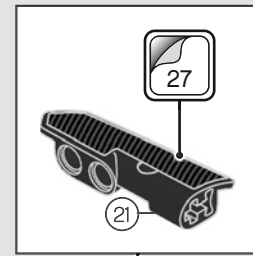

660

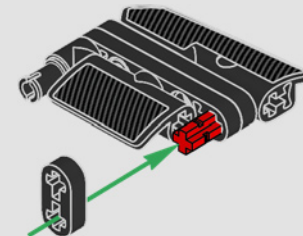

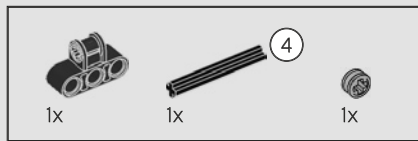

661

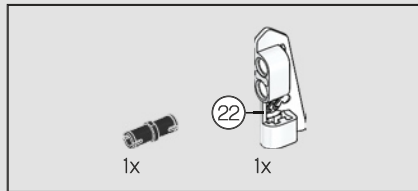
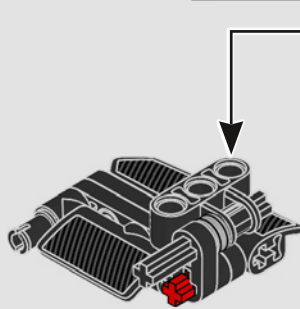
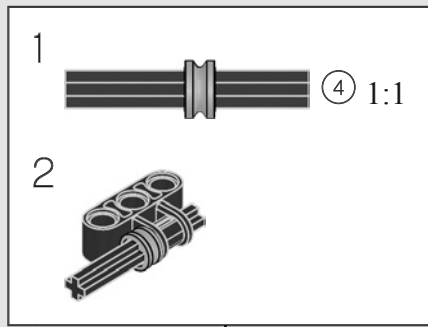

662

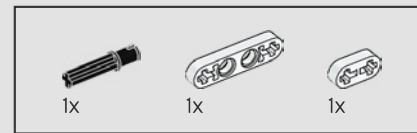
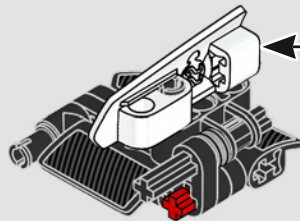
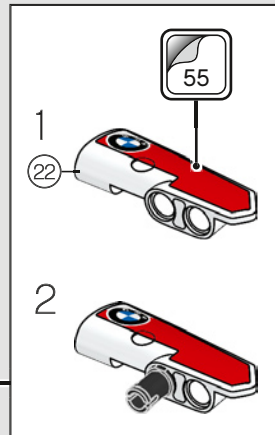

663

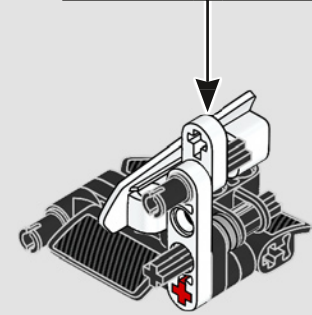
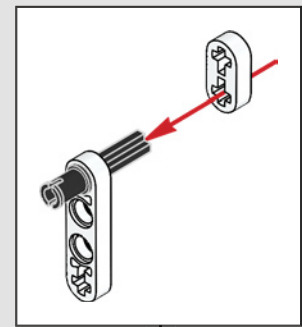

664

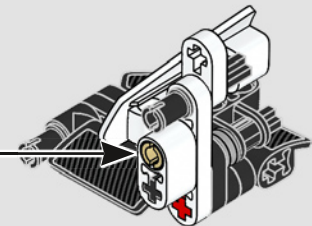
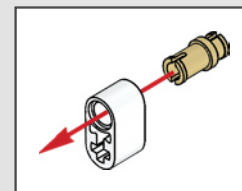

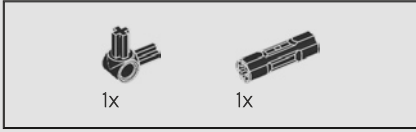
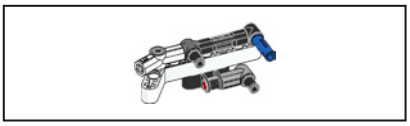

665

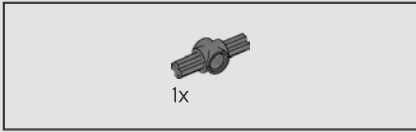
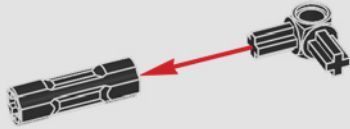

666

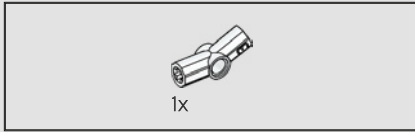
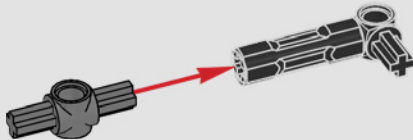

667

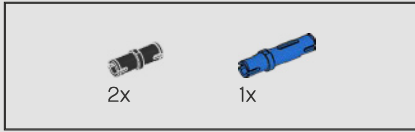

668

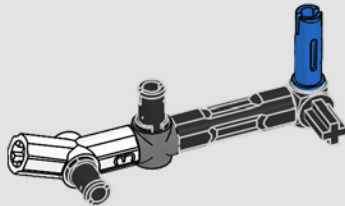

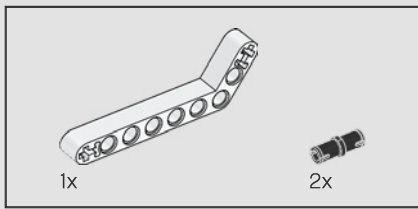

669

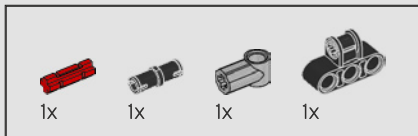
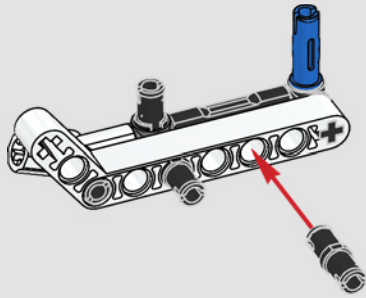

670

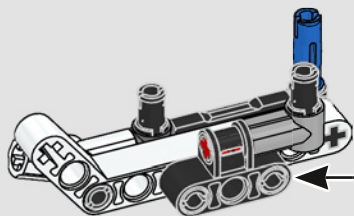
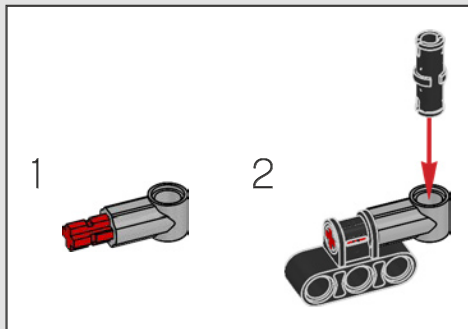

671

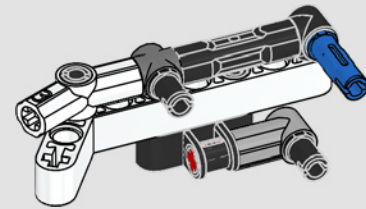

672

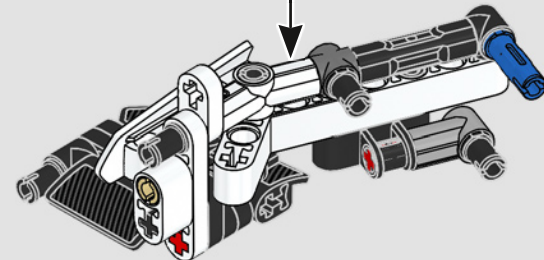



673

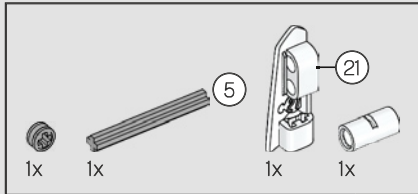
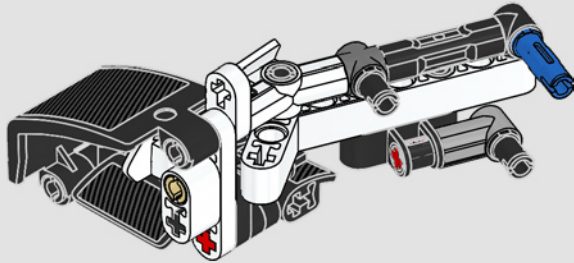
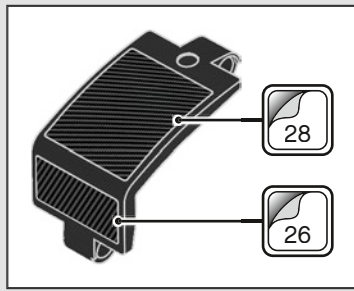

674

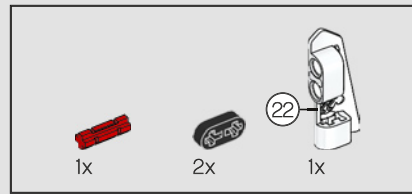
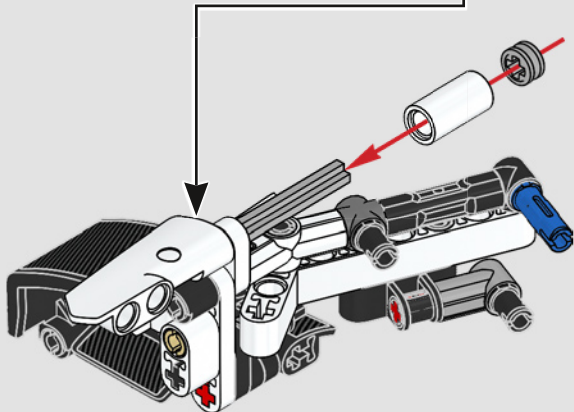
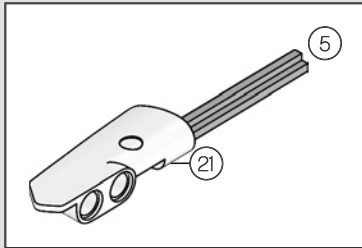

675

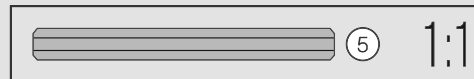
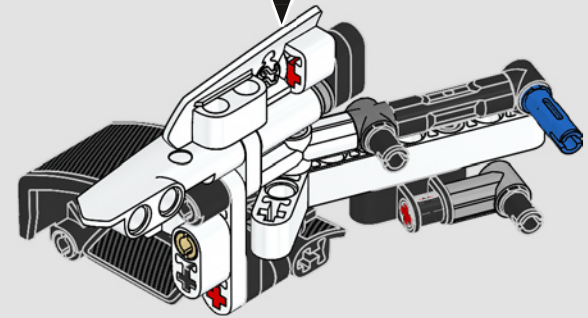
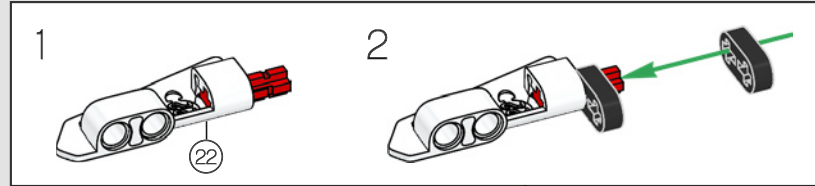

676

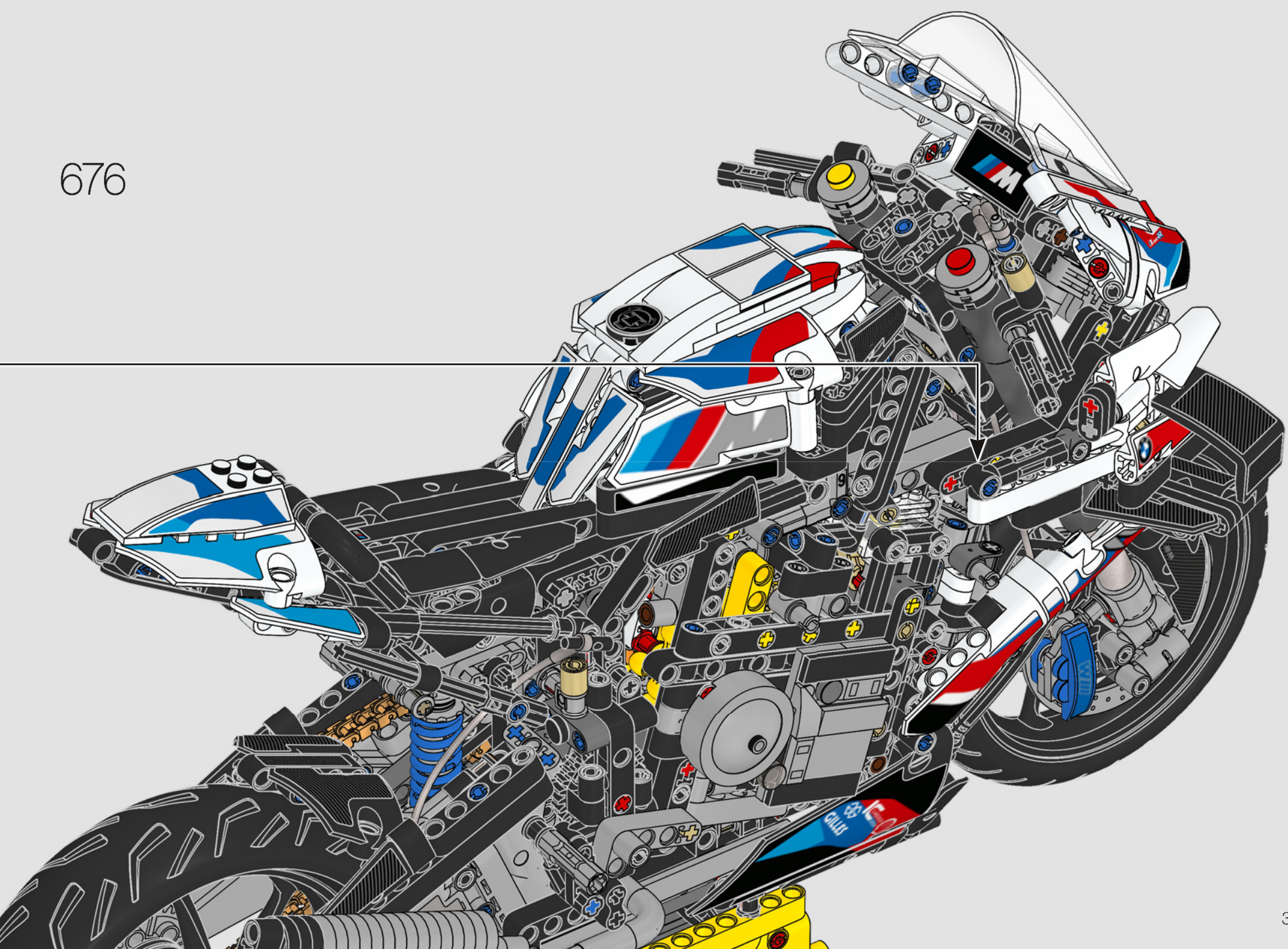

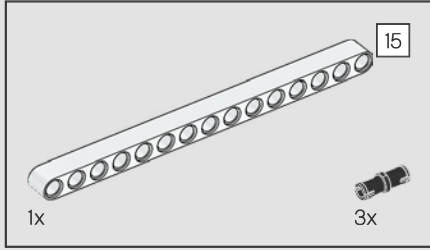
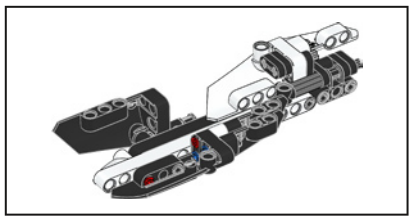

677

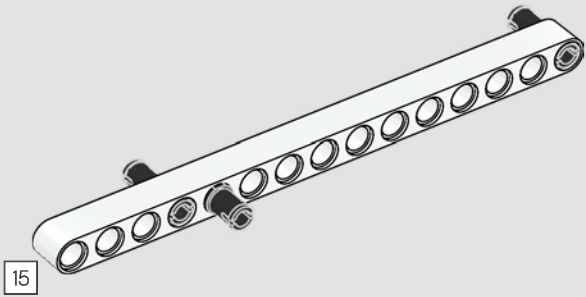

678

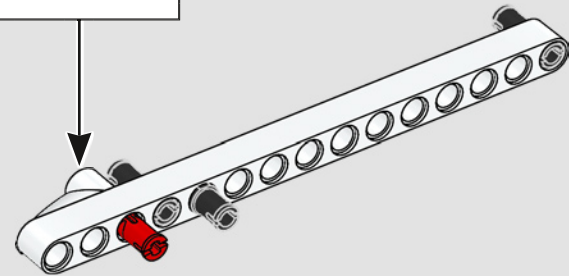
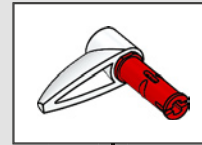

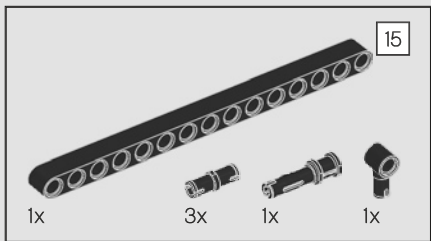

679

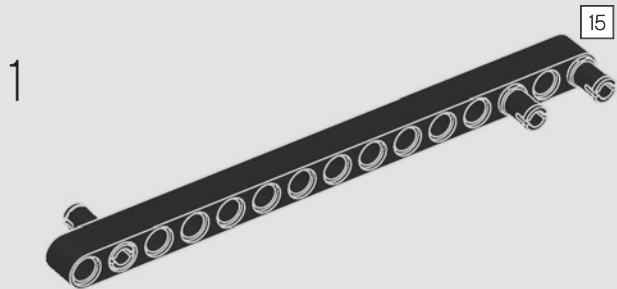

2

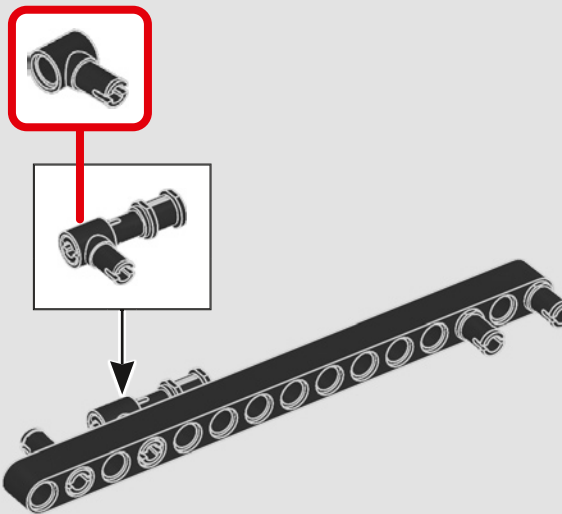

680

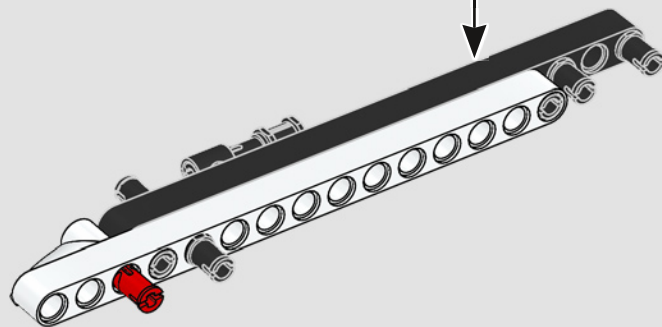

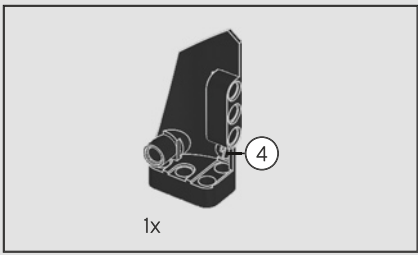

681

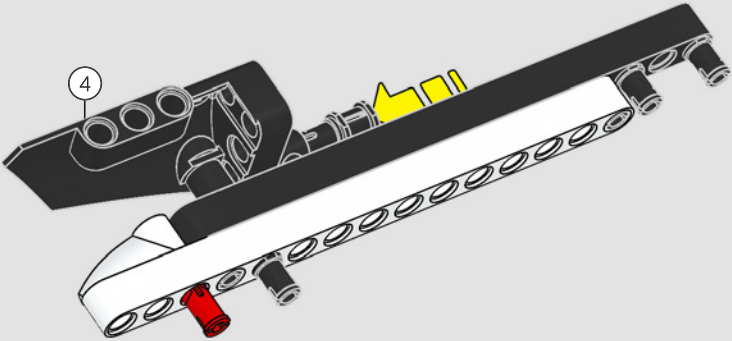

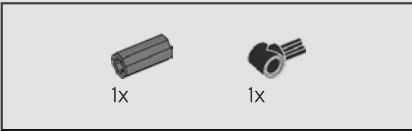
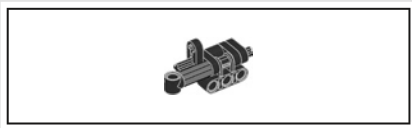

682

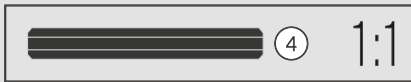
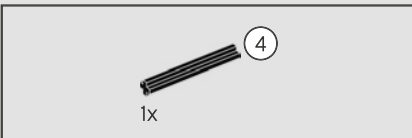
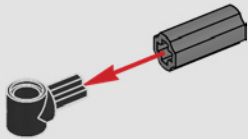

683

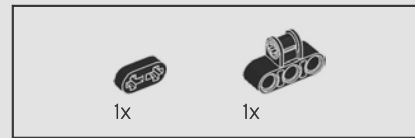
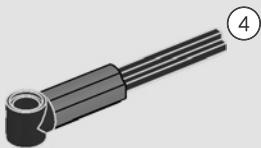

684

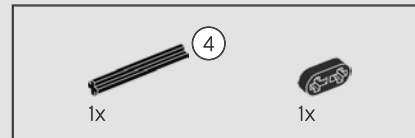
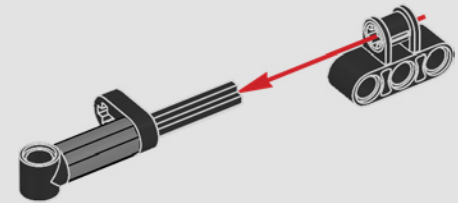

685

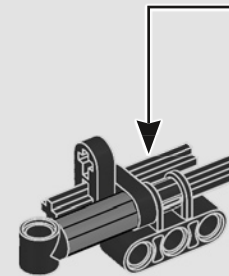



686

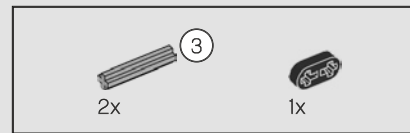
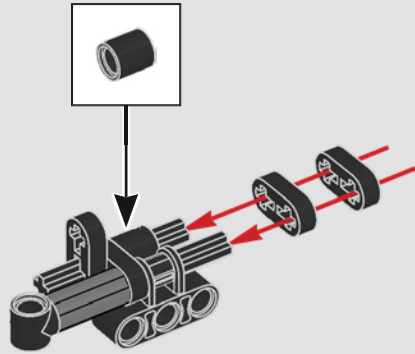

688

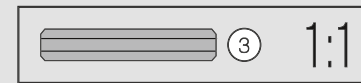
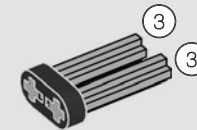

689

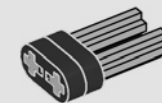

687

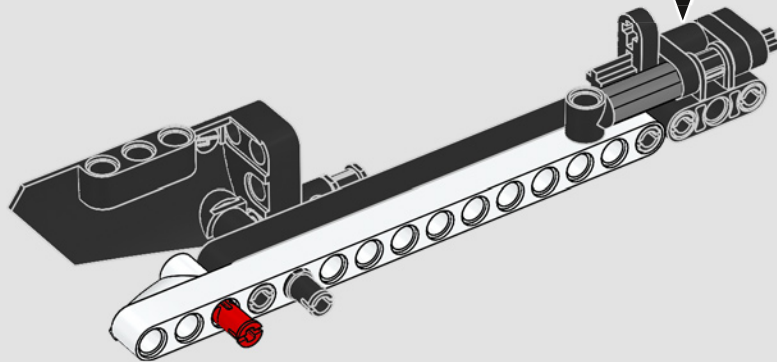

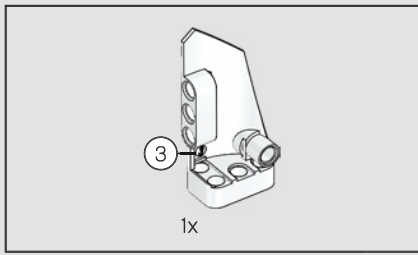

690

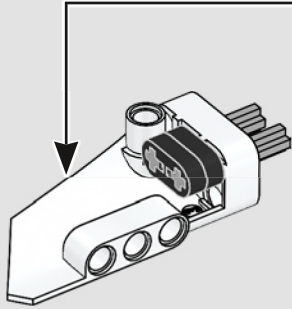
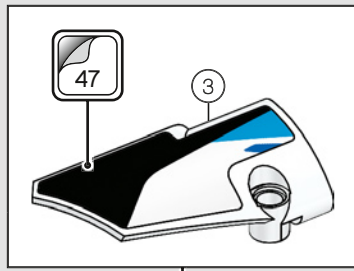

691

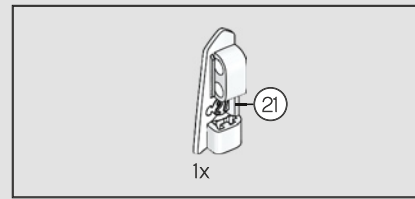
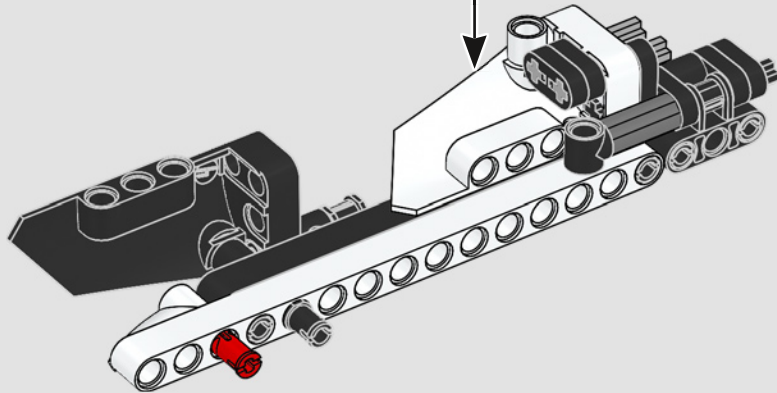

692

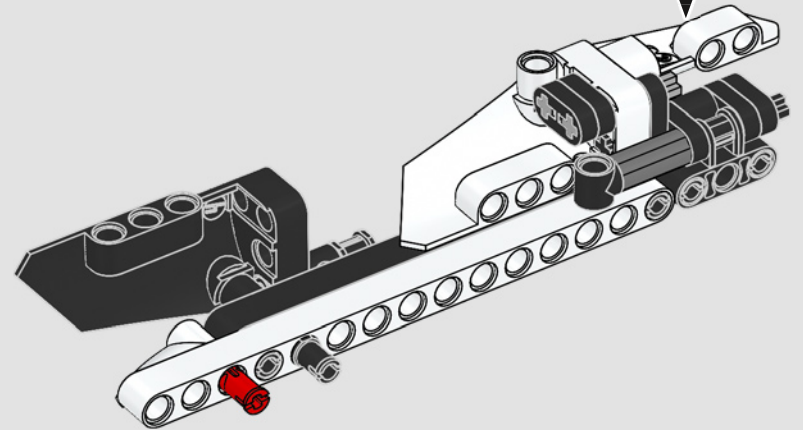
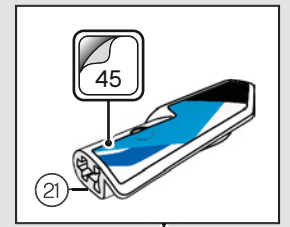

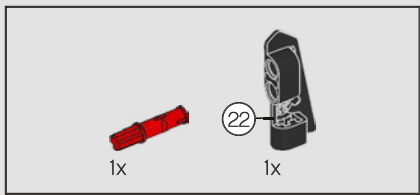

693

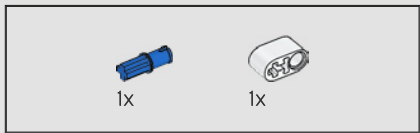
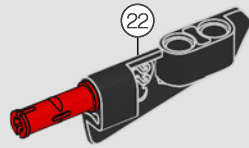

694

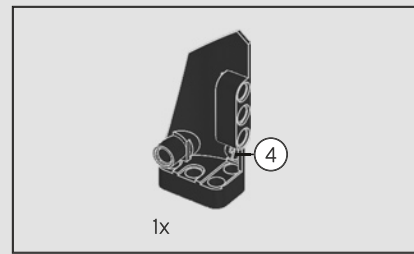
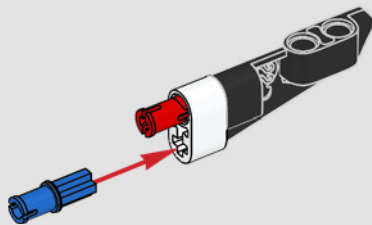

695

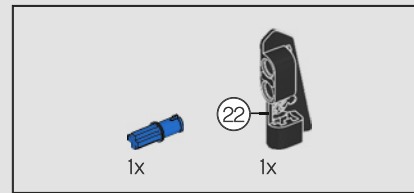
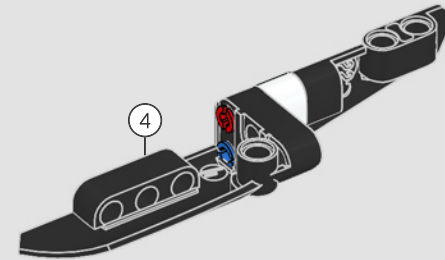

696

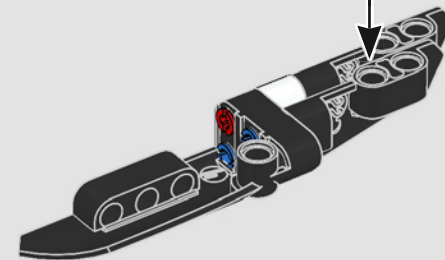
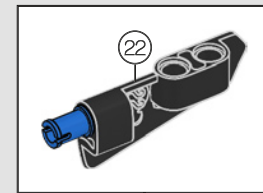

697

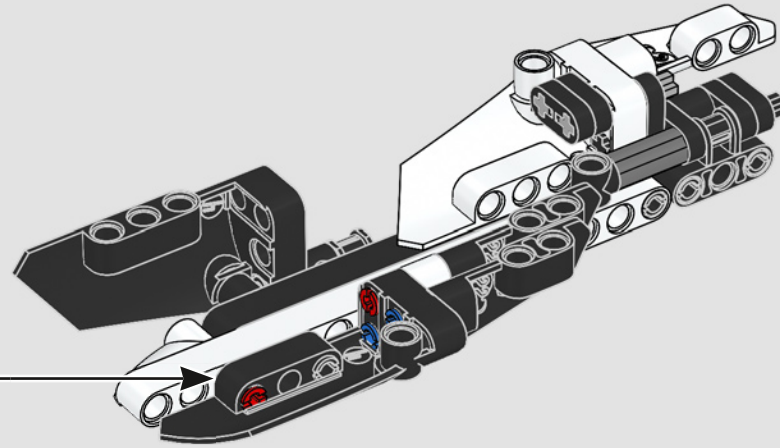

698

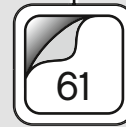
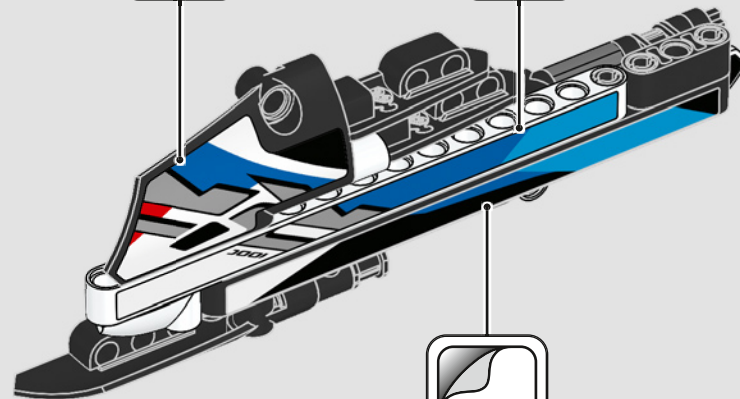

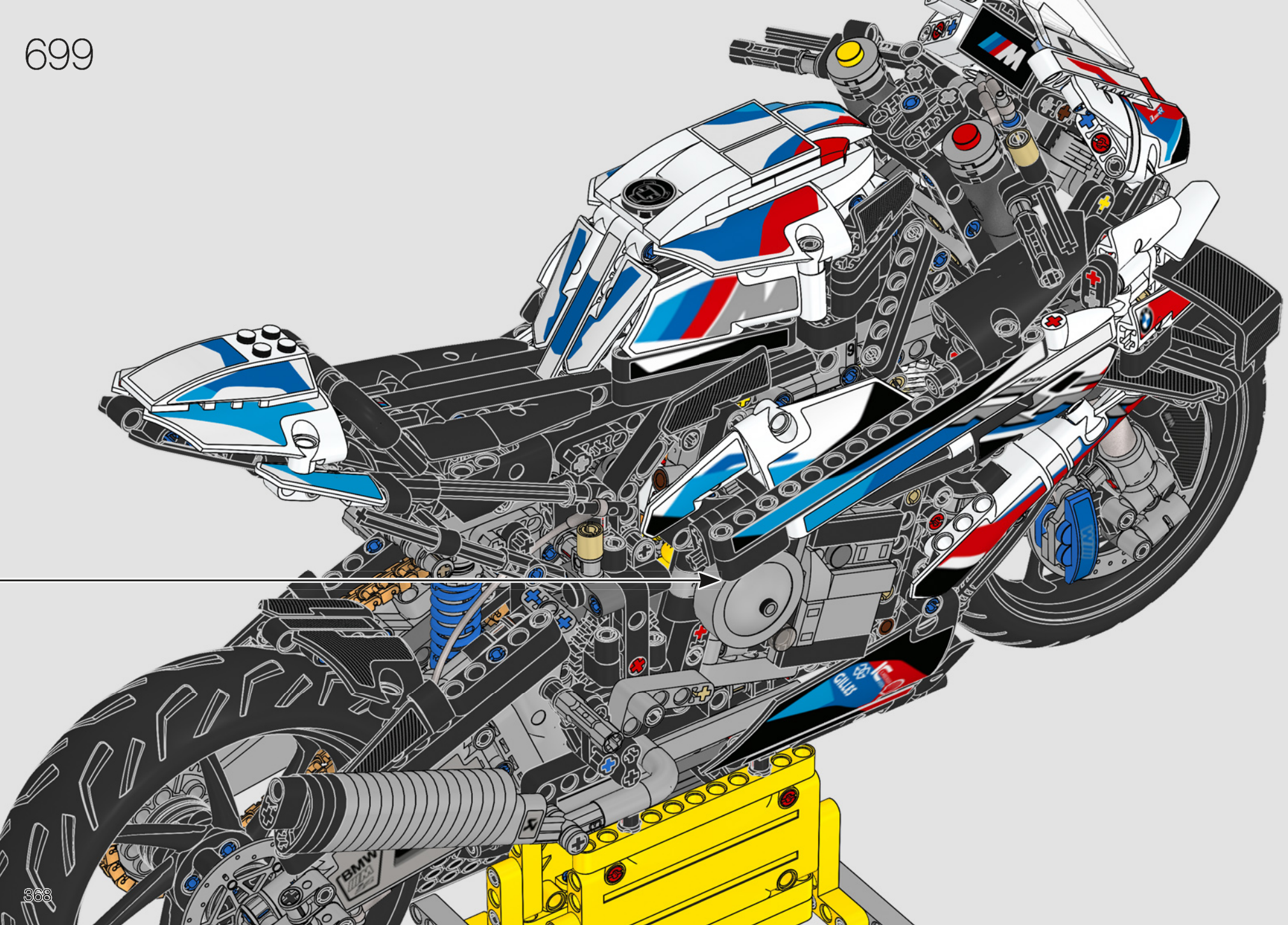

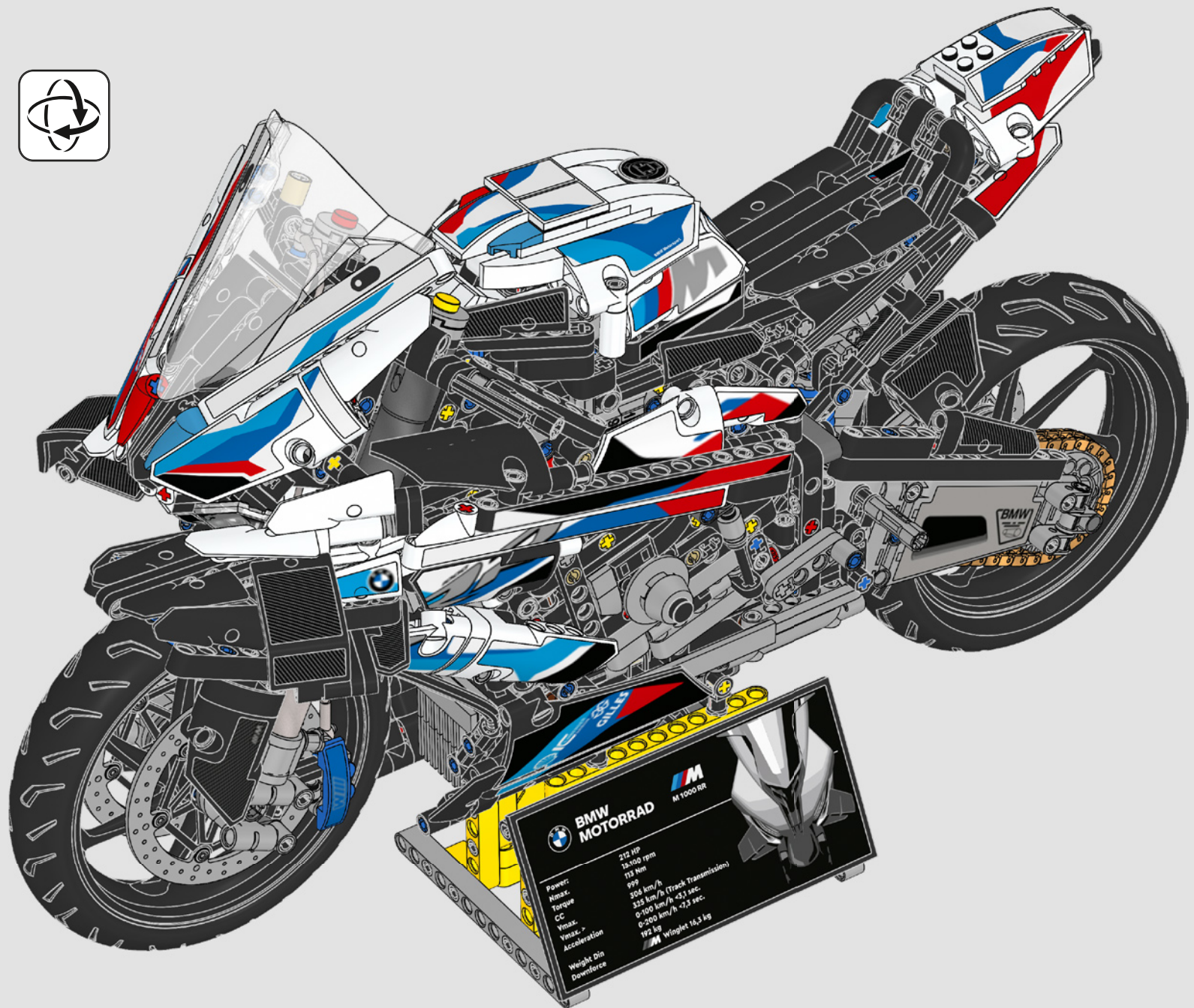

BMW
MOTORRAD

M
M 1000 RR

212 HP
15,500 rpm
113 Nm
99
306 km/h
335 km/h (Track Transmission)
0-100 km/h < 3.1 sec.
0-200 km/h < 7.3 sec.
192 kg
Winglet 16.3 kg

Power:
Hmax.
Torque
CC
Vmax.
Acceleration
Weight
Din
Downforce

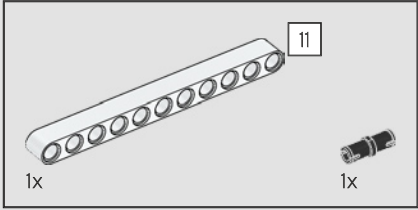
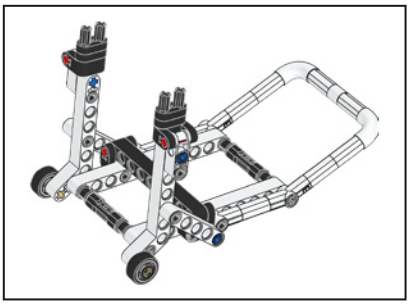

1

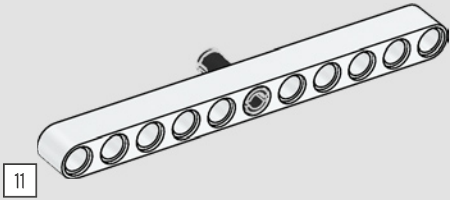

2

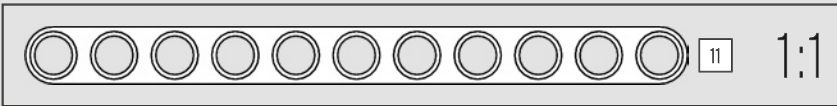
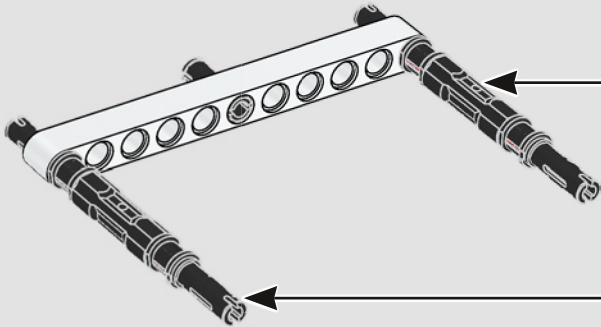
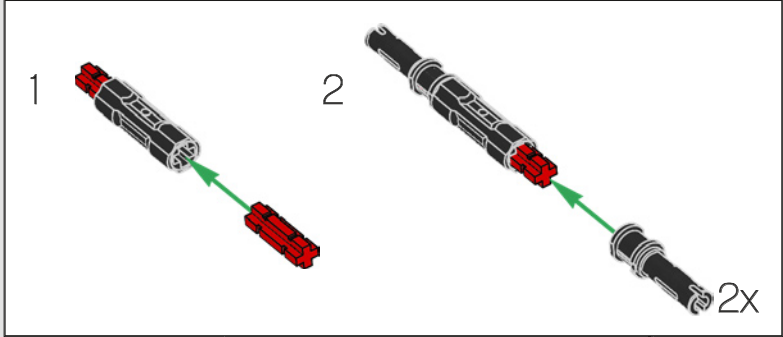

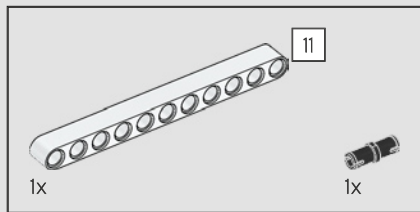

3

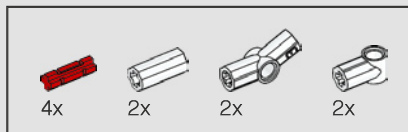
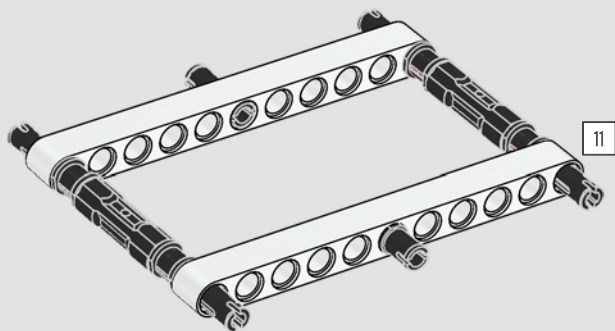

4

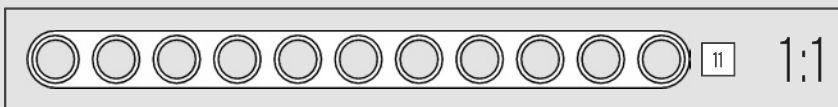
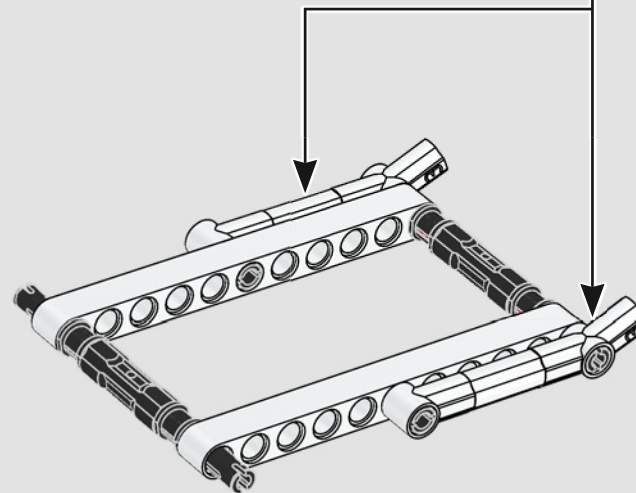
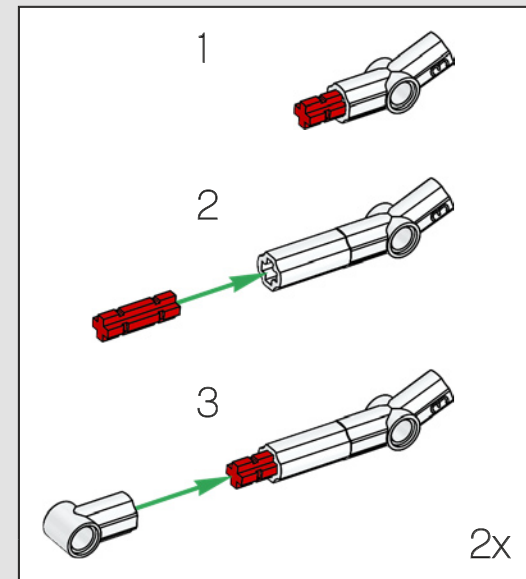

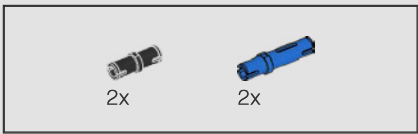

5

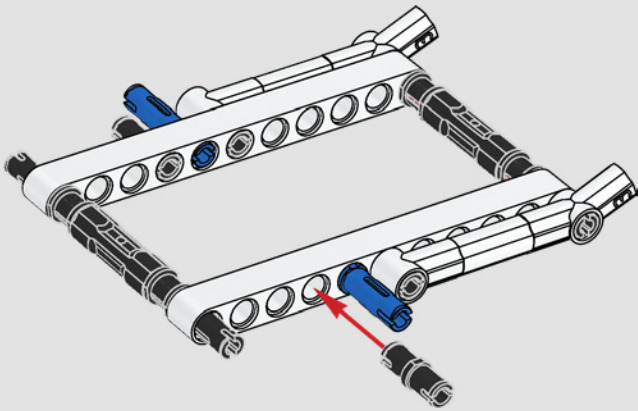

6

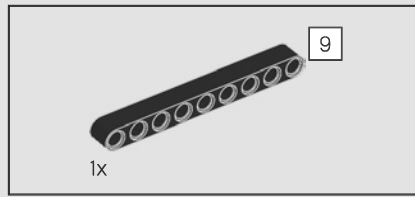
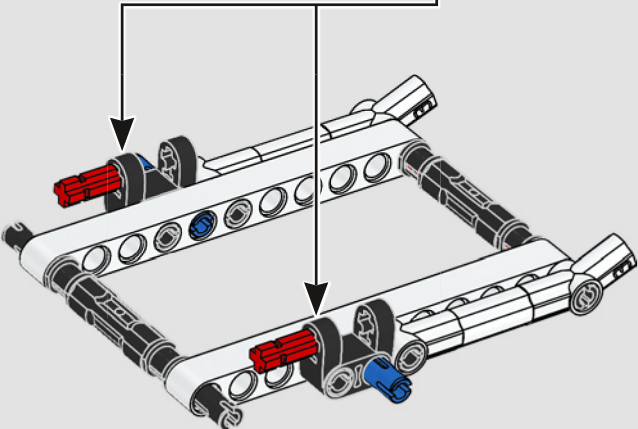
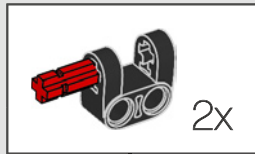

7

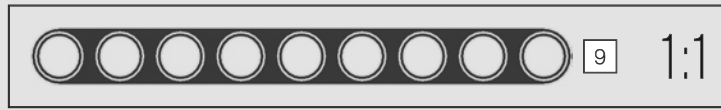
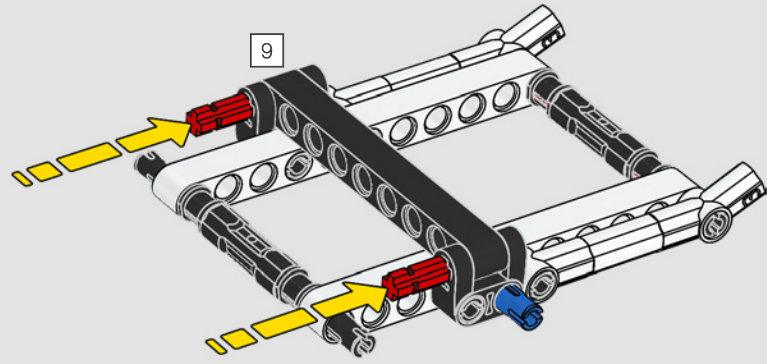

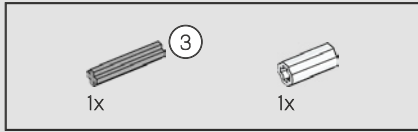
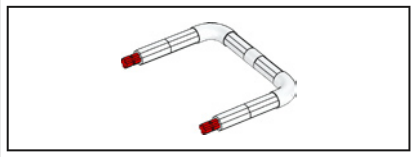

8

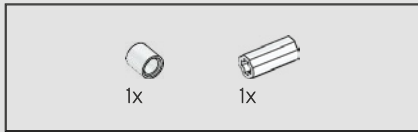
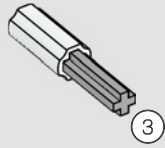

9

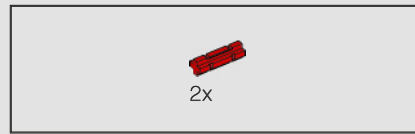
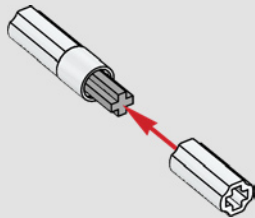

10

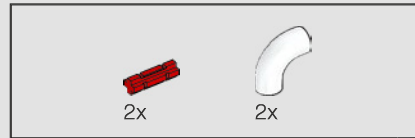
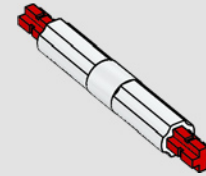

11

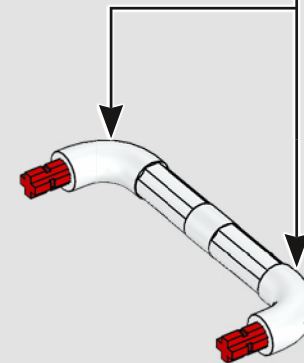
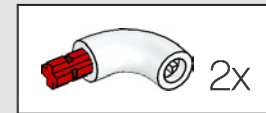

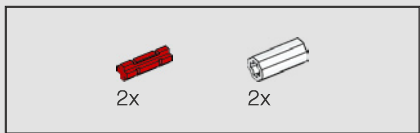

12

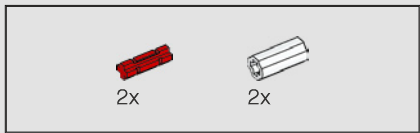
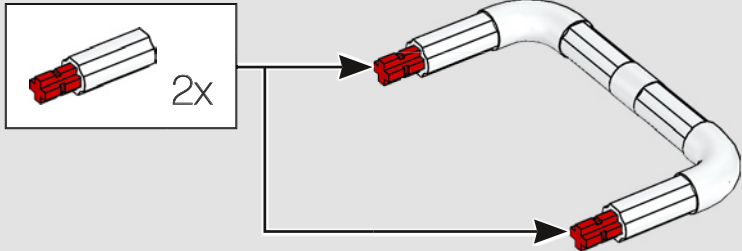

13

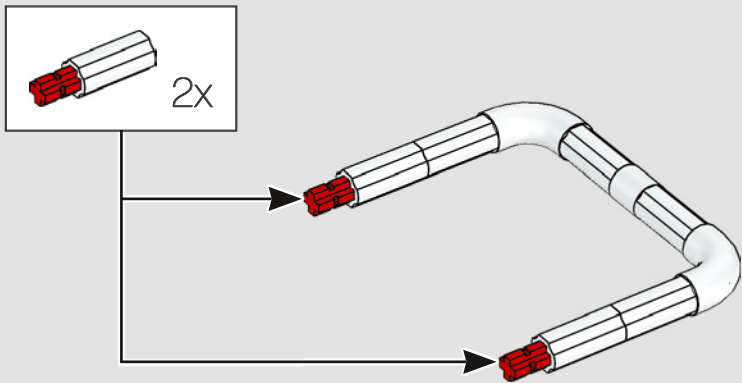

14

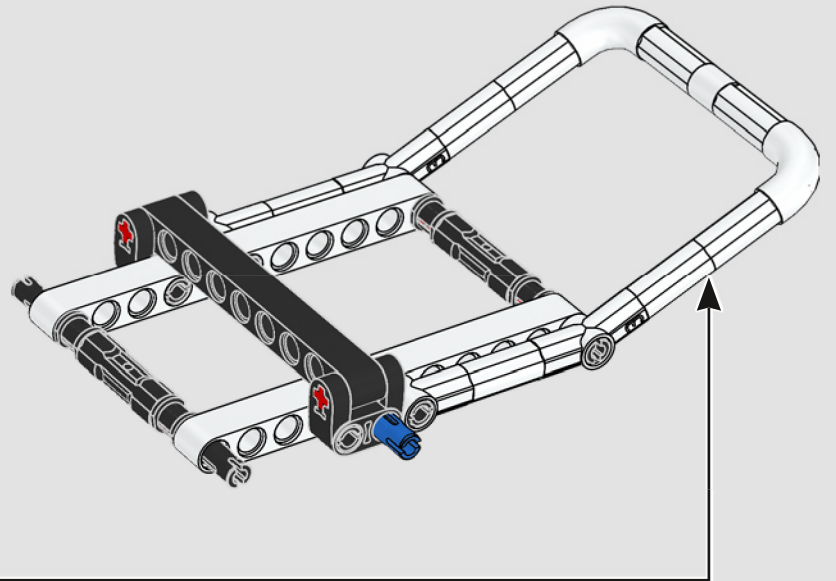

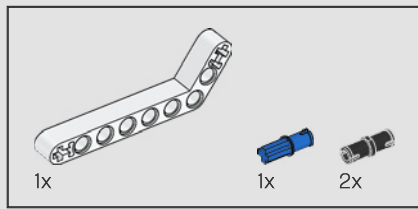

15

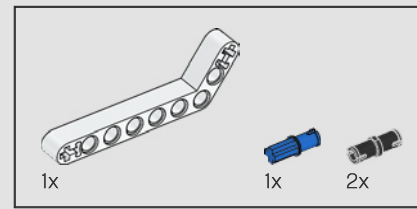
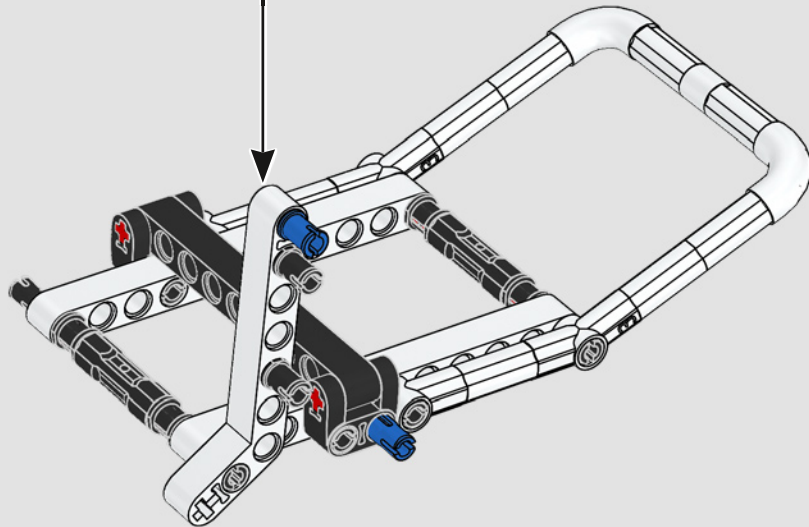
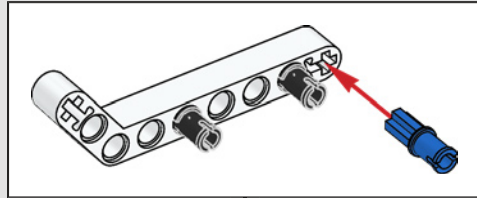

16

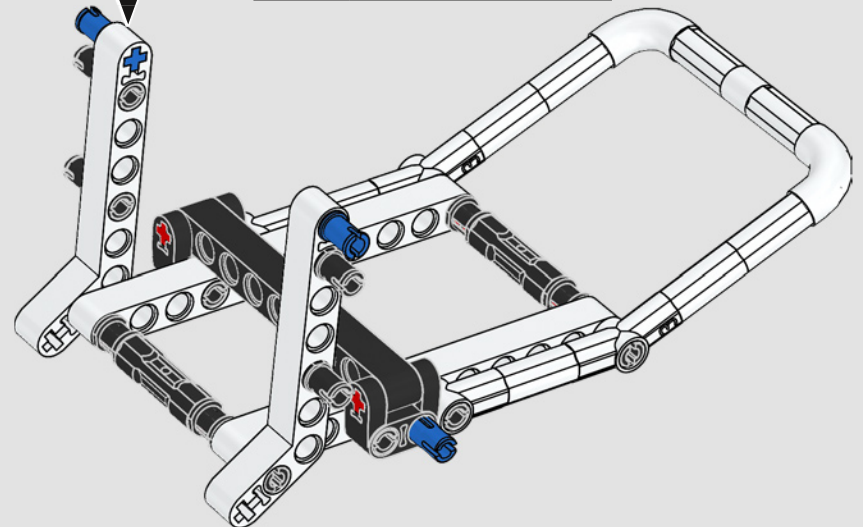
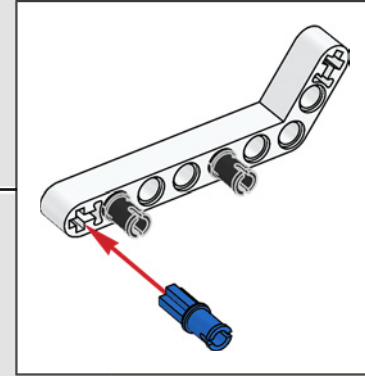

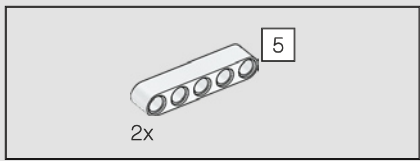

17

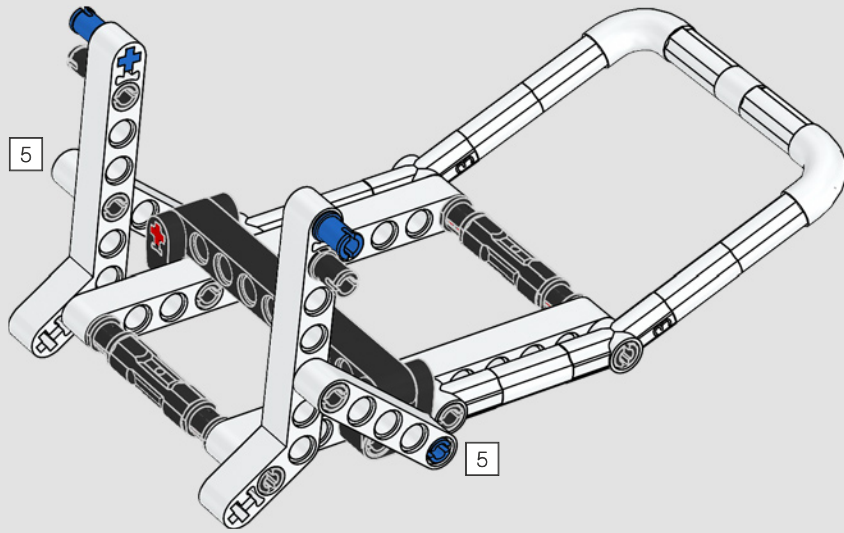

18

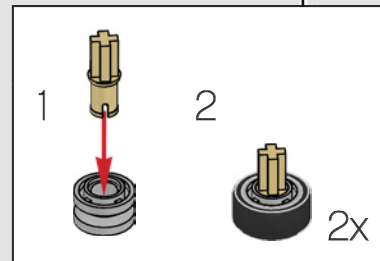
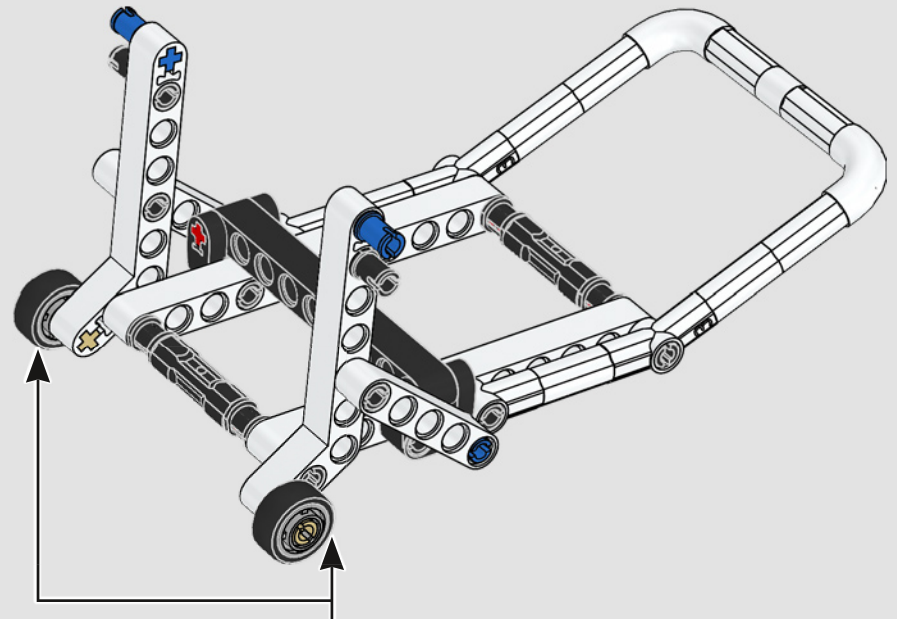



19

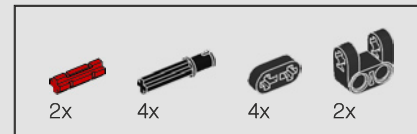
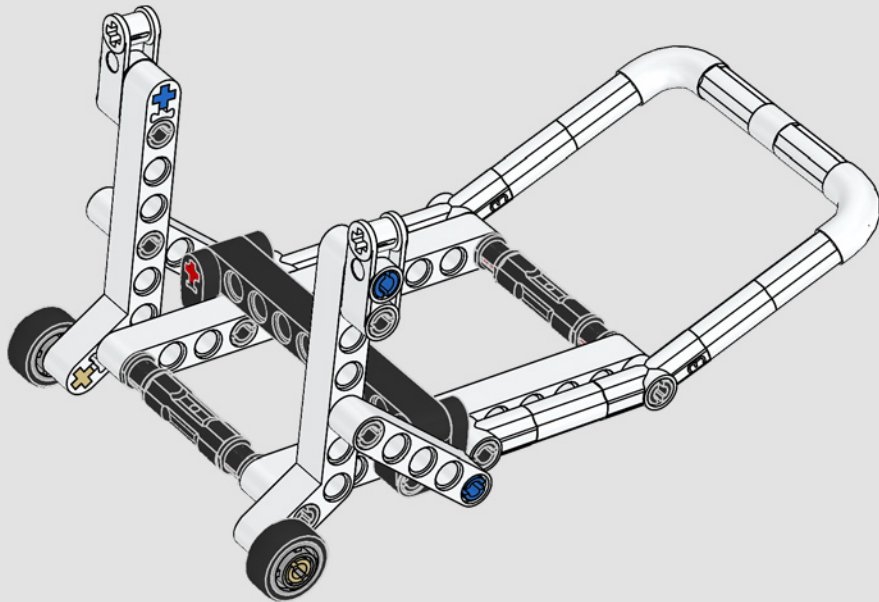

20

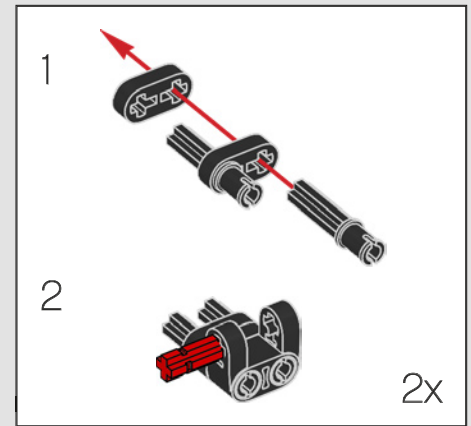
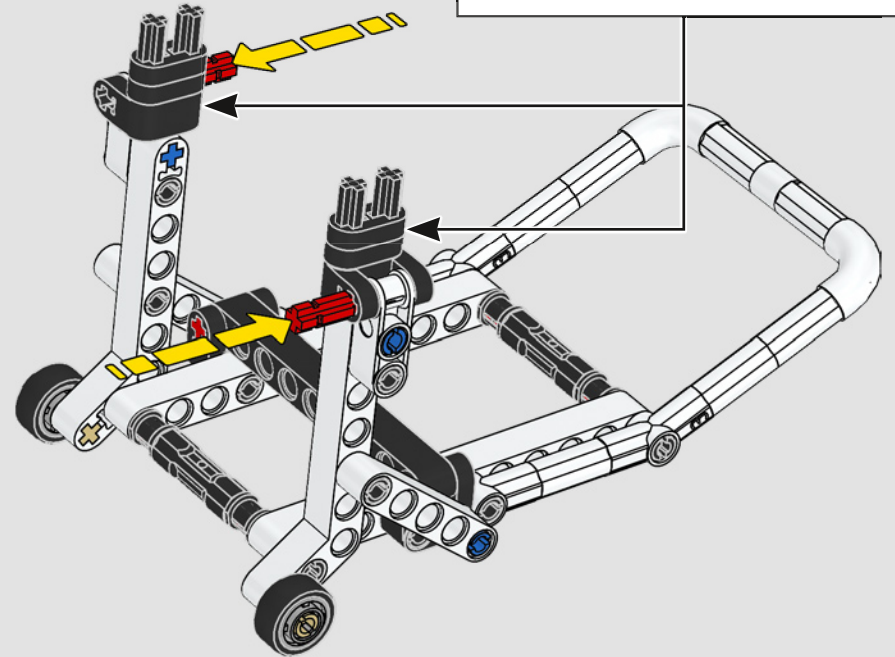

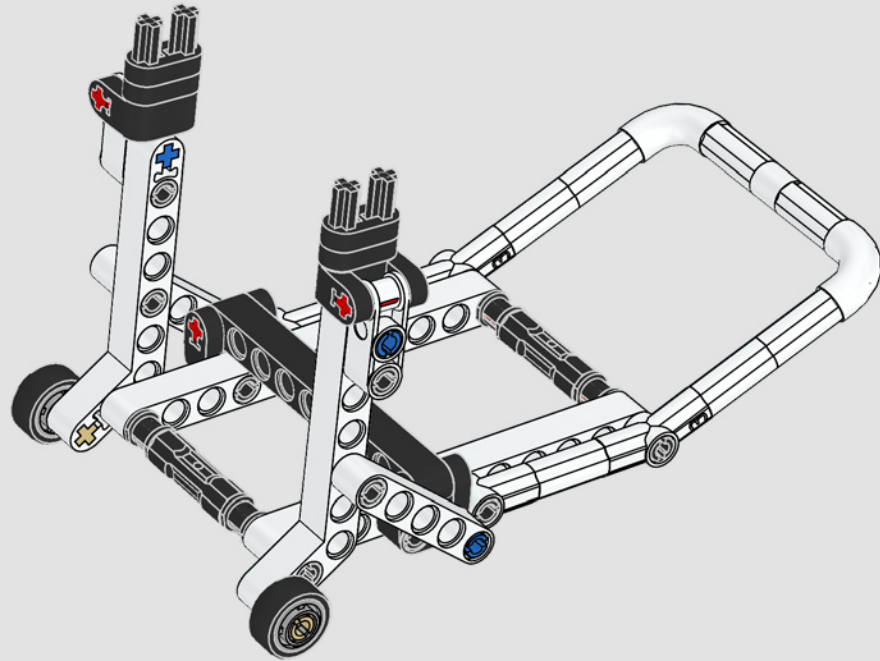

700

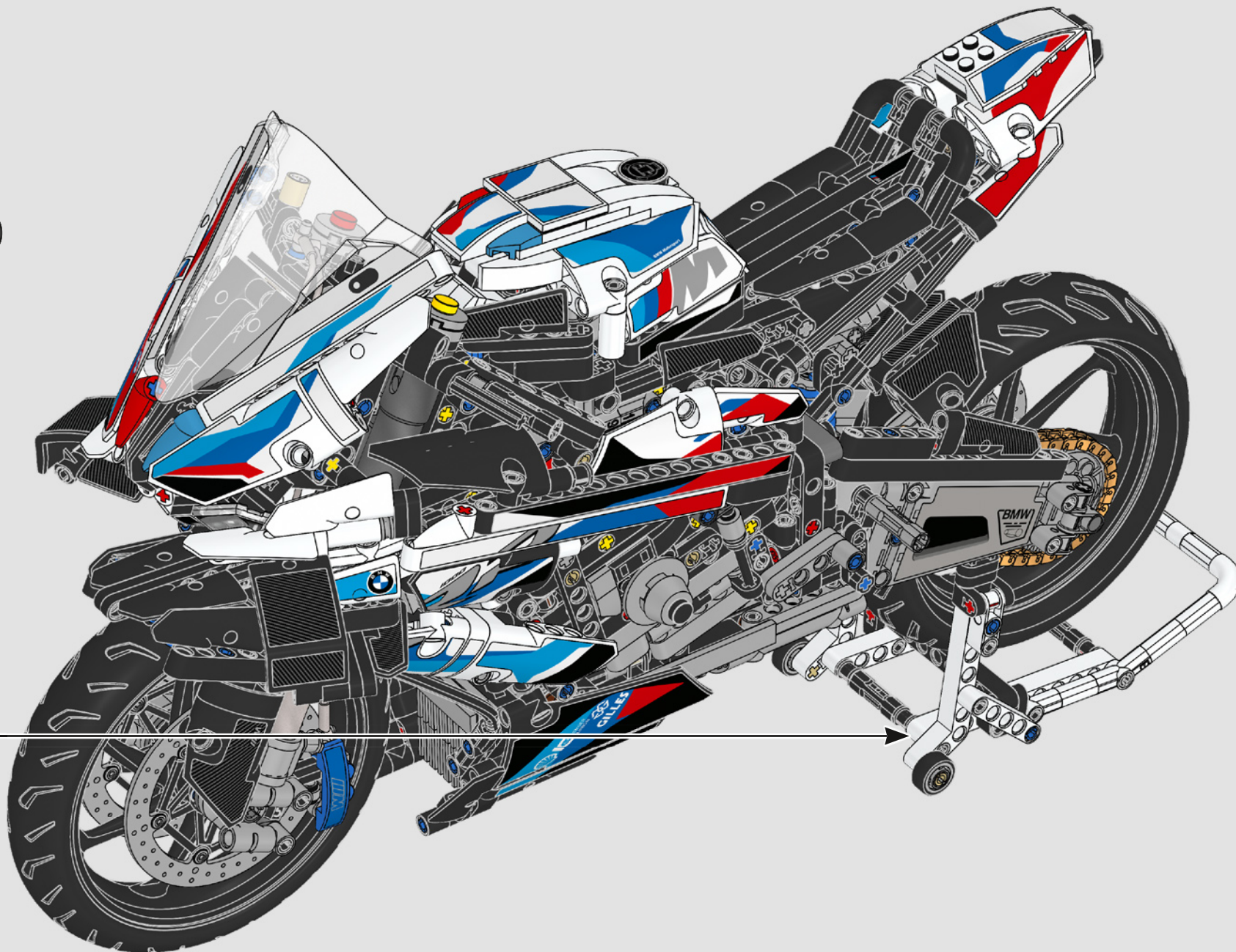

- 1x 6177114
- 2x 6282148
- 2x 4544140
- 7x 6343987
- 10x 6371416
- 2x 6323918
- 7x 6330084
- 2x 6332573
- 2x 6194851
- 2x 6179606
- 7x 6265135
- 4x 6345327
- 8x 6212049
- 2x 3200001
- 6x 6173116
- 3x 6034044
- 2x 6271349
- 2x 6288218
- 2x 6330960
- 1x 6047220
- 4x 6261390
- 2x 6271870
- 2x 4249112
- 1x 362301
- 2x 4249021
- 2x 366601
- 1x 4558874
- 1x 4558878
- 2x 6360072
- 6x 4547582
- 2x 302101
- 1x 6132212
- 2x 6156667
- 6x 4547581
- 2x 6045936
- 2x 302001
- 2x 4249021
- 2x 366601
- 1x 4179869
- 5x 6276842
- 4
- 9
- 11
- 15
- 3
- 5
- 2
- 1

- 1x 303401
- 4x 6001831
- 4x 6028103
- 2x 4542578
- 3x 6167923
- 15x 6013938
- 3x 6355727
- 5x 4666579
- 2x 6346517
- 1x 6321305
- 2x 4666999
- 1x 6284574
- 13x 6271820
- 4x 6360104

- 1x 6177507
- 62x 4142865
- 2x 6167939
- 7x 6100930
- 1x 4179355
- 1x 6285599
- 1x 6273712
- 37x 6209519
- 5x 6347789
- 3x 6273211
- 4x 6129995
- 1x 4142132
- 1x 6130002
- 2x 6130004
- 4x 6284575
- 37x 4143005
- 4
- 5
- 6
- 8

- 2x 6315482
- 69x 4206482
- 1x 6224999
- 2x 6344176
- 132x 6299413
- 2x 4649773
- 1x 6284577
- 4x 4112203
- 1x 403224
- 2x 4187122
- 2x 4119474
- 3x 6284189
- 7x 6130008
- 10x 4144022
- 7
- 7
- 9
- 11
- 11
- 6x 6028107
- 7x 6130012
- 2x 6311003
- 1x 6170421
- 3x 6284070
- 3x 6168646
- 17x 6121485
- 23x 6282140
- 1x 6181720

- 2x 4177431
- 14x 6319983
- 2x 6196548
- 1x 6181713
- 3x 4143187
- 2x 4246901
- 43x 6338428
- 6x 6322045
- 4x 6261371
- 12x 6316923
- 6x 6284699
- 207x 6279875
- 2x 403226
- 4x 6179182
- 1x 6070695
- 16x 6253260
- 8x 6099801
- 34x 6265091
- 10x 6326047
- 8x 4512363
- 4x 6280394
- 6x 6331716
- 10x 6349281
- 2x 6268905
- 1x 6174243
- 1x 6047276
- 1x 6156991
- 2x 6147050
- 4x 6271346
- 3x 6325521

- 8x 6313520
- 2x 6262897
- 10x 6271810
- 4x 6323668
- 3x 6273708
- 2x 242026
- 2x 4124096
- 25x 6089119
- 27x 6321745
- 4x 4107765
- 4x 6261386
- 1x 6276951
- 3x 4552347
- 2x 4142822

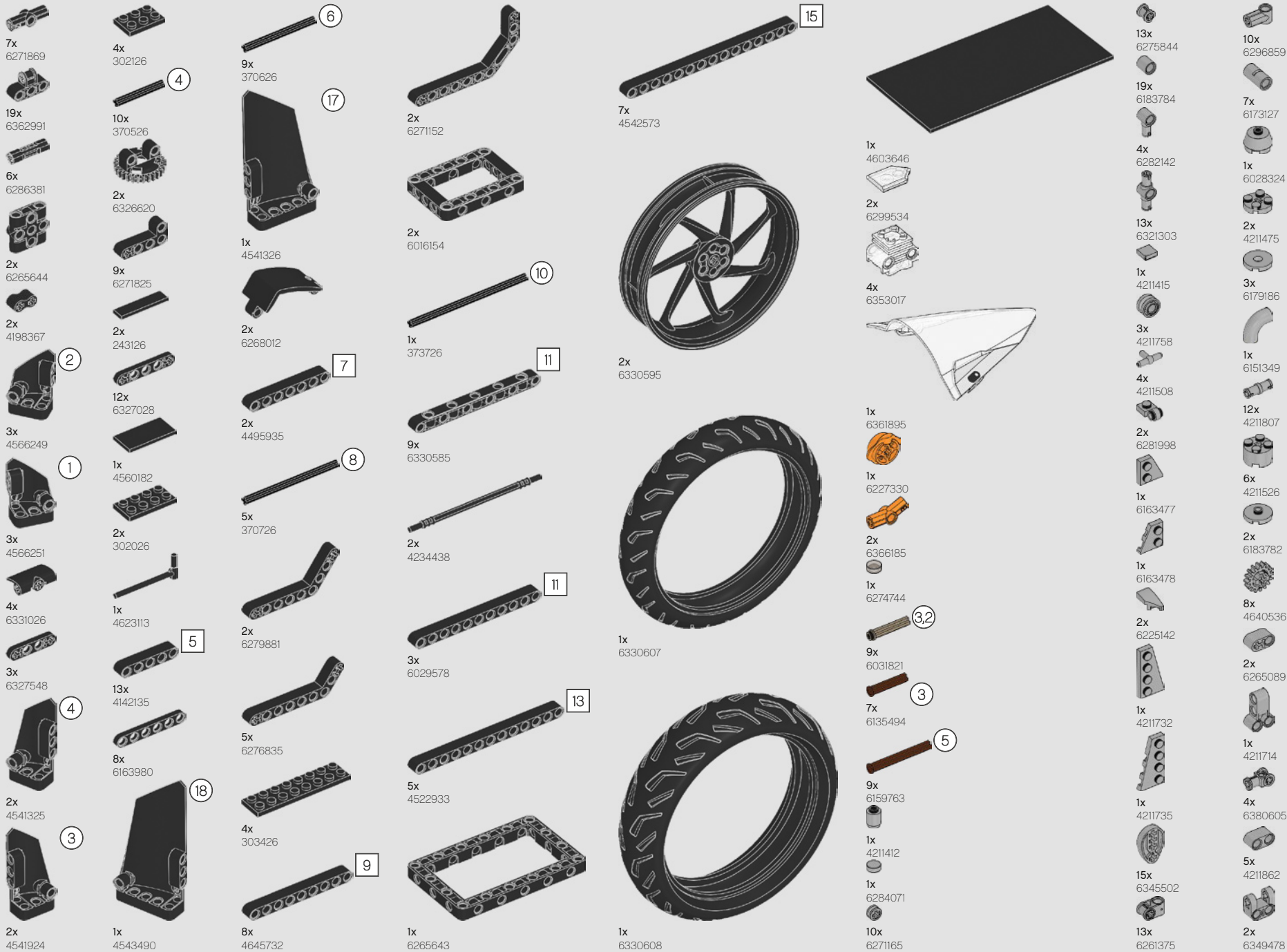



2x
6280396



4x
6268924



6x
6168633



2x
6134378



2x
4211469



30x
4211350



4x
6000018



1x
4667578



2x
6331859



4x
6360043



2x
6262905



7x
6273724



4x
6279023



4x
4211397



1x
4490127



33x
4211815



1x
4211536



1x
6261387



2x
4652235



13x
6276969



3x
6331441



2x
6282158



1x
6070564



1x
4211429



1x
6211969



1x
4558169



2x
6302648



2x
6317177



1x
6013547

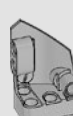

1x
6011808



2x
6273212



2x
6370947



1x
4211396



1x
6171894



1x
6271831



2x
4211356



2x
4211445



1x
6303438



4x
6328063



4x
6331428



3x
4503416



7x
4211639



1x
6195314



2x
4211651



6x
4211713



1x
6285654



10x
6170293



1x
6278129



1x
4211549



6x
4211805



2x
4211452



9x
4495930



2x
6257136

5



2x
4211481

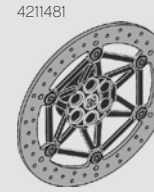

2x
6331551

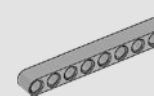

1x
6102449

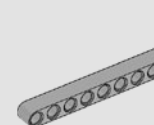

2x
4522934

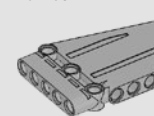

2x
6327007

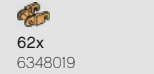

62x
6348019

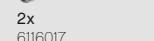

2x
6116017



3x
6210590



2x
6328490

9

13



1x
6211418



1x
6292486



1x
6364922



1x
6284596



4x
4210759



8x
6261374



2x
6100931



3x
6135014



2x
4516546



2x
6364452



6x
6167281



1x
6133119



11x
4210751



1x
6317653



2x
4610378



3x
6271814



7x
6083620



3x
4499858



3x
6321715



2x
4645730



1x
4603472

4

8

9

11



Customer Service
Kundenservice
Service Consommateurs
Servicio Al Consumidor

LEGO.com/service or dial

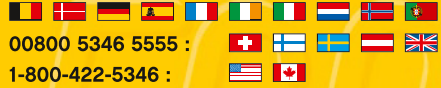

00800 5346 5555 :

1-800-422-5346 :



FEEDBACK AND WIN



FEEDBACK AND WIN

Your feedback will help shape the future development of this product series.

Please visit:

FEEDBACK UND GEWINNEN

Dein Feedback trägt zur Weiterentwicklung dieser Produktreihe bei.

Geh auf:

COMMENTEZ ET GAGNEZ

Vos commentaires nous aideront à concevoir les futurs produits de cette gamme.

Rendez-vous sur :

COMENTA Y GANA

Tu opinión nos ayudará a dar forma al desarrollo de esta serie de productos en el futuro.

Visita:

反馈有奖

您的反馈将有助于我们在今后改进本系列产品。

请访问：

[LEGO.com/productfeedback](https://www.lego.com/productfeedback)

By completing, you will automatically enter a drawing to win a LEGO® set.

Terms & Conditions apply.

Durch Ausfüllen nimmst du automatisch an der Verlosung eines LEGO® Preises teil.

Es gelten die Teilnahmebedingungen.

En envoyant vos commentaires, vous serez automatiquement inscrit(e) à un tirage au sort qui vous permettra de remporter un prix LEGO®.

Offre soumise à conditions.

Al contestar, participarás automáticamente en el sorteo y podrás ganar un set LEGO®.

Sujeto a Términos y Condiciones.

完成我们的反馈调查，即可自动进入抽奖环节，赢取乐高®套装。

适用《条款和条件》。

LEGO and the LEGO logo are trademarks of the/son des marques de commerce du/son marcas registradas de LEGO Group. ©2022 The LEGO Group.

The BMW logo, the BMW Motorrad word mark and the BMW Motorrad model designation are trademarks of BMW AG and are used under license.



M 1000 RR