



BRICK SKETCHES™

40456



Disney
MICKEY
AND FRIENDS

Mickey Mouse

Some time ago I was a part of an artists' group on a popular social media platform. Many of the artists were doing marker sketches on small cardstock as a way to engage with their fans. I thought this was a fantastic idea, but I wanted to put my own spin on it using LEGO® bricks. This led to the creation of the very first Brick Sketch. I posted it to my social media channels with some apprehension, not entirely sure how my fans would react. Thankfully, they loved the concept and wanted to see more!

After some experimenting, I nailed down the basics: Brick Sketches would be plate-based artwork that featured a front-facing character on a 12x16 canvas. Given that Brick Sketches are somewhat three-dimensional, it was also important that they have correct relief wherever possible; for example, the character's chin shouldn't extend further out than the nose. The challenge was to use LEGO pieces creatively to build detailed character artwork on a relatively small canvas.

Brick Sketches became far more popular than I ever expected. Fans loved suggesting new characters and often asked me to create instructions so that they could build their favourites. It was difficult to set aside the concept when I started working at the LEGO Group, but through an amazing series of events, Brick Sketches are now available from the LEGO Group itself. It's a dream come true.



LEGO® designer Chris McVeigh

Booklet available in English on
Heft in deutscher Sprache erhältlich auf
Livret disponible en français sur
Libretto disponibile in Italiano su
Folleto disponible en español en
如需中文版手册，请访问

[LEGO.com/service/buildinginstructions](https://www.lego.com/service/buildinginstructions)



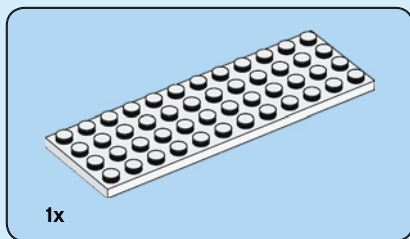

1

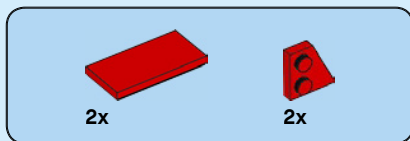
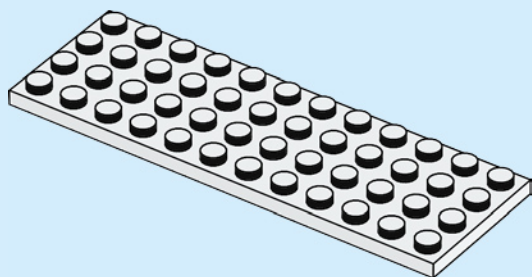

2

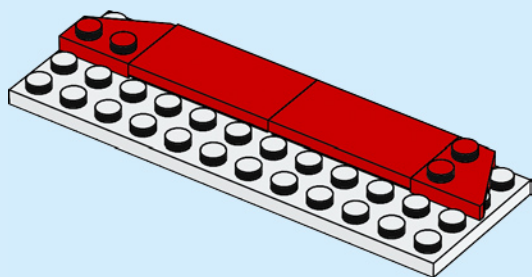

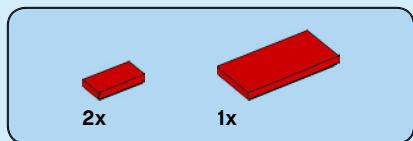

3

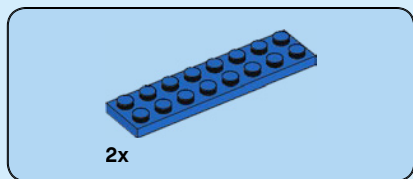
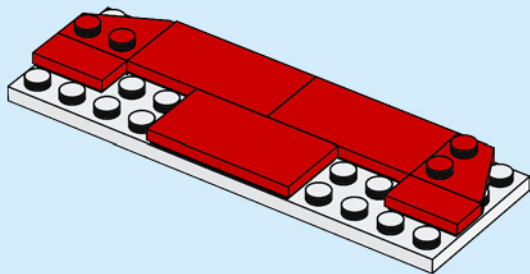

4

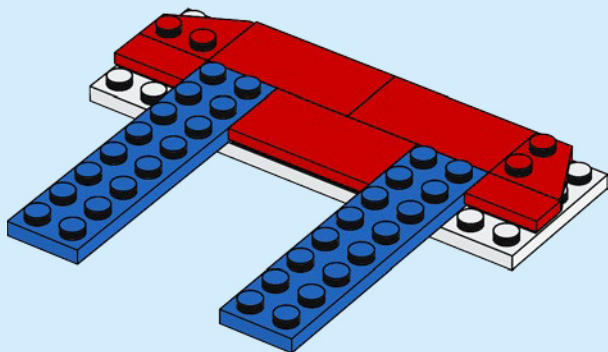

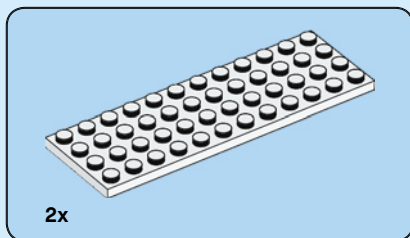

5

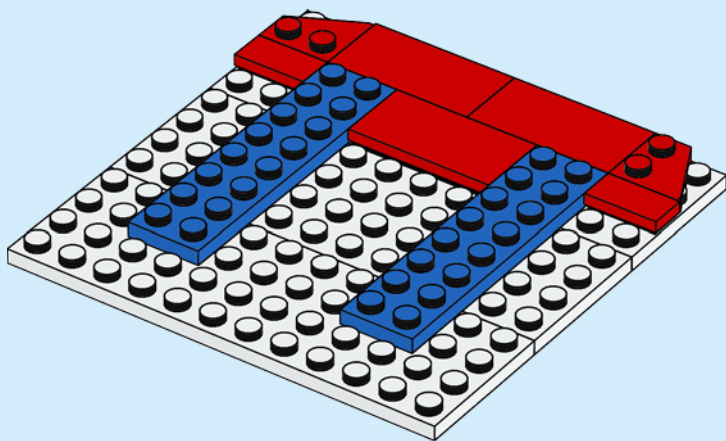

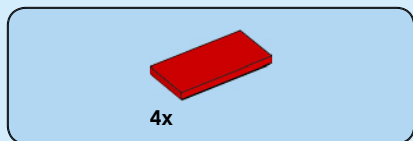

6

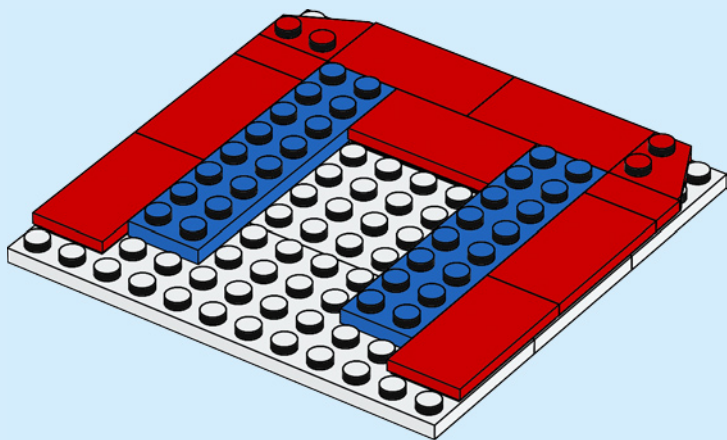

8

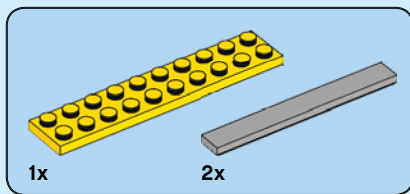

7

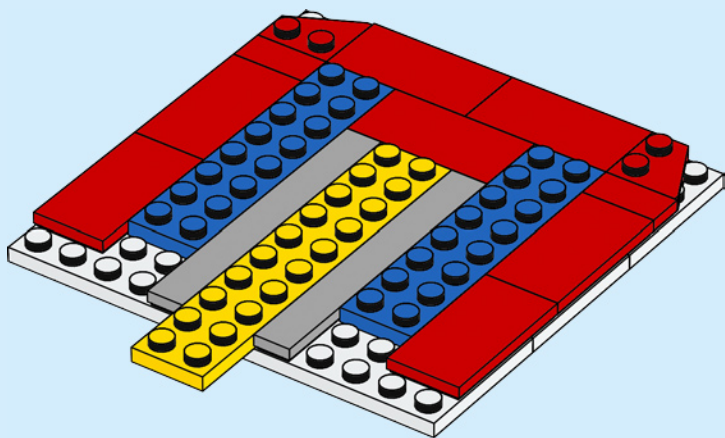

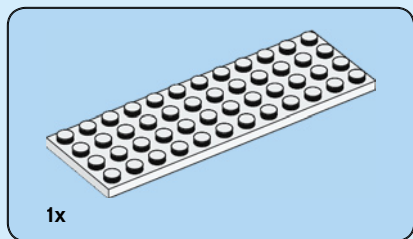

8

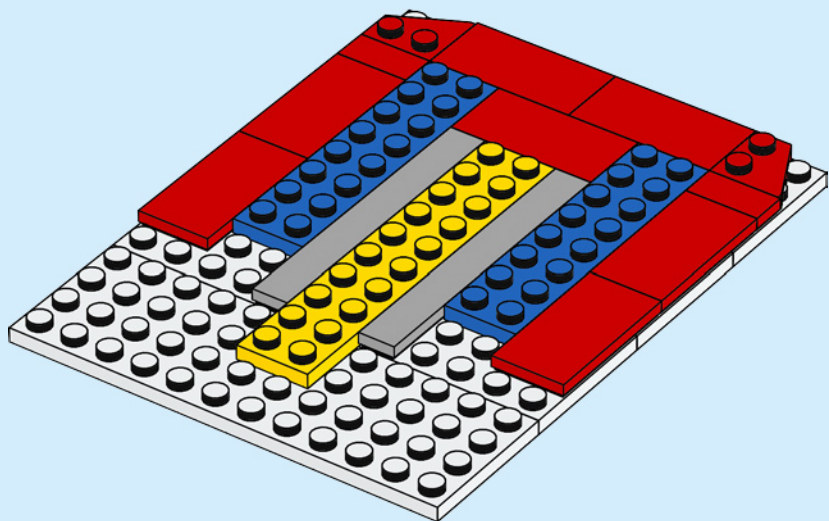

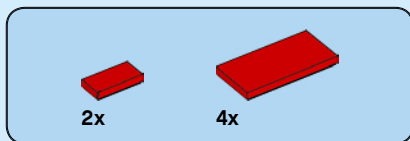

9

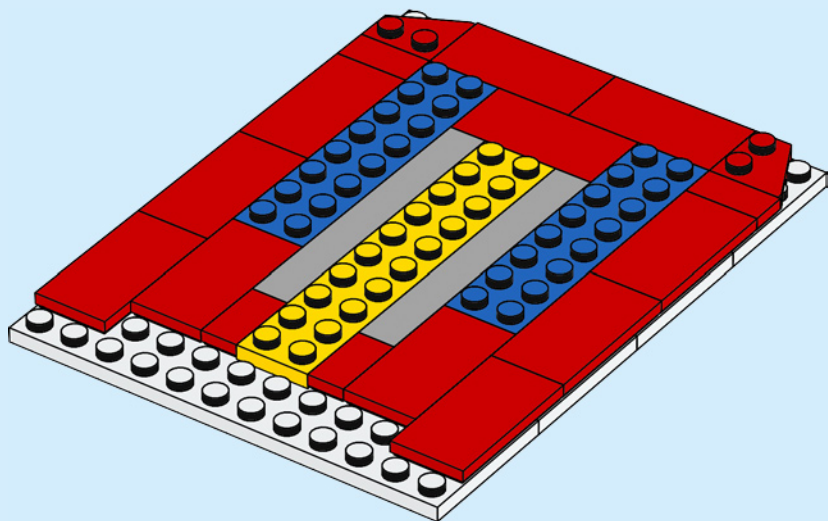

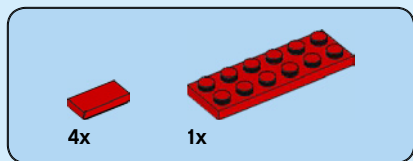

10

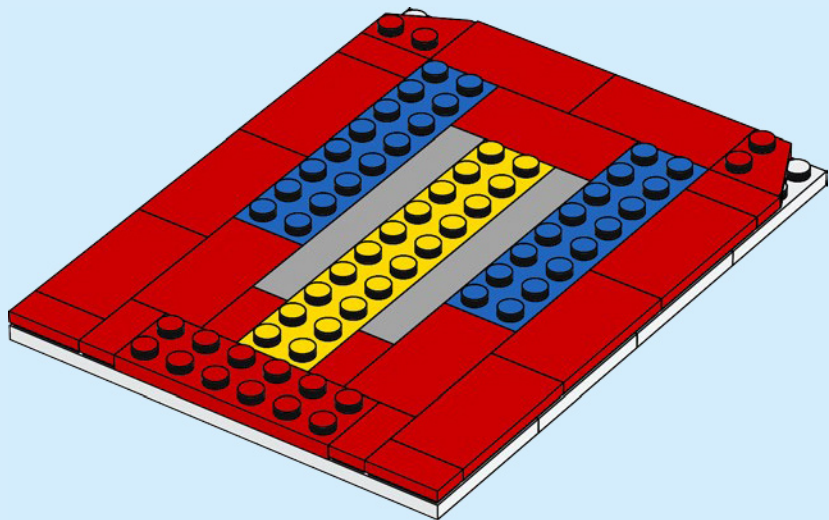

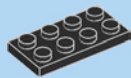

2x

11

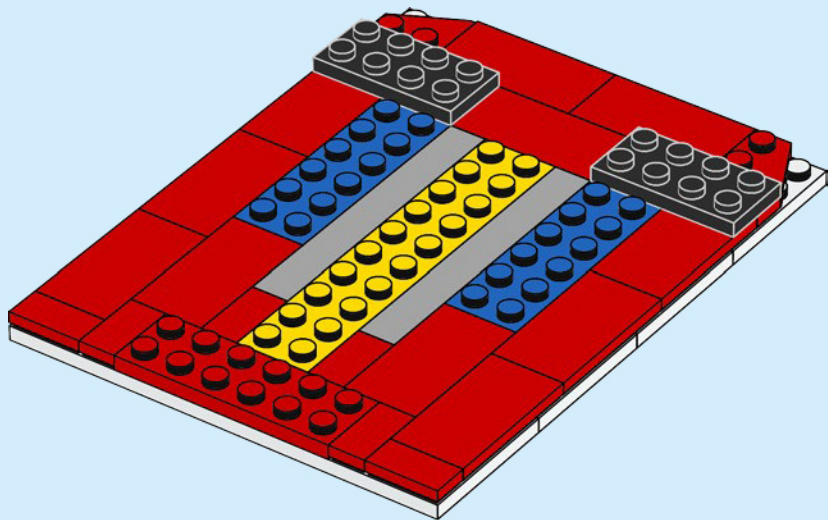

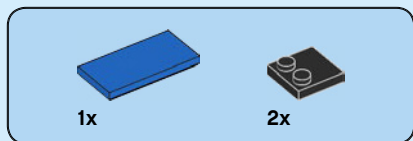

12

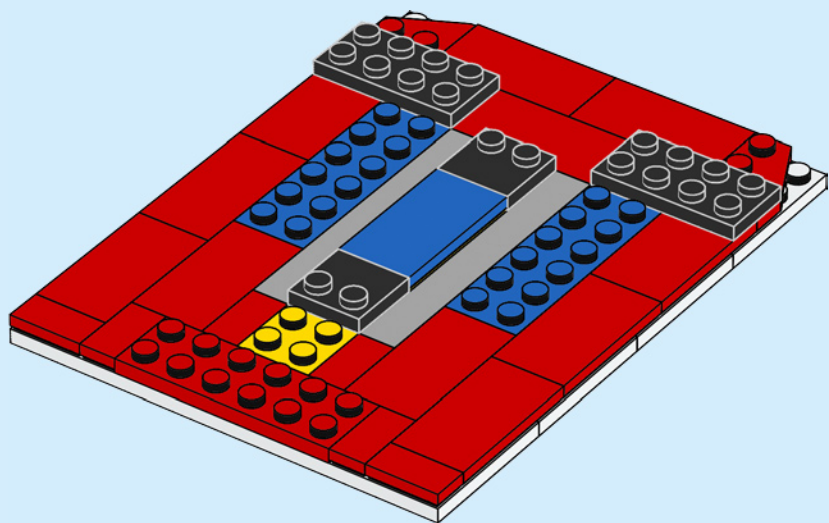

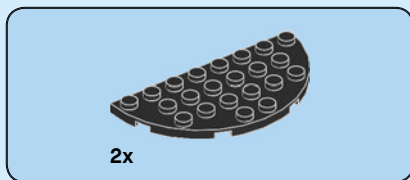

13

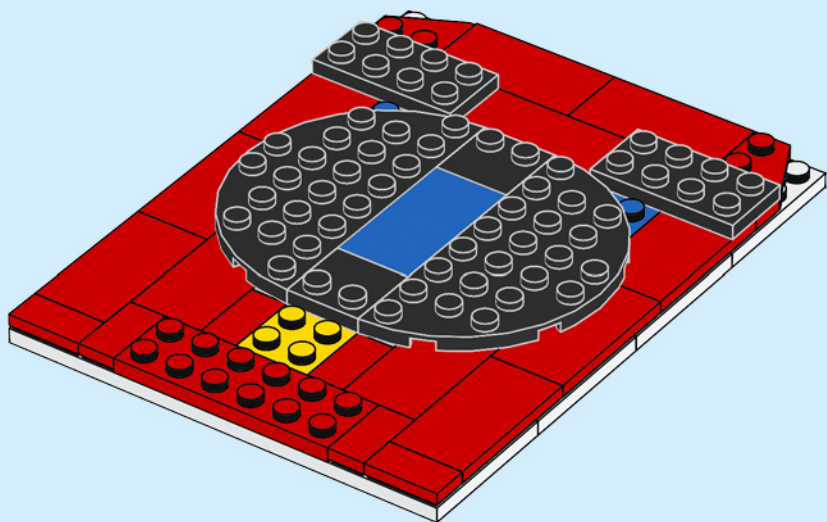

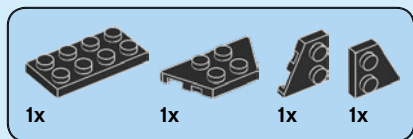

14

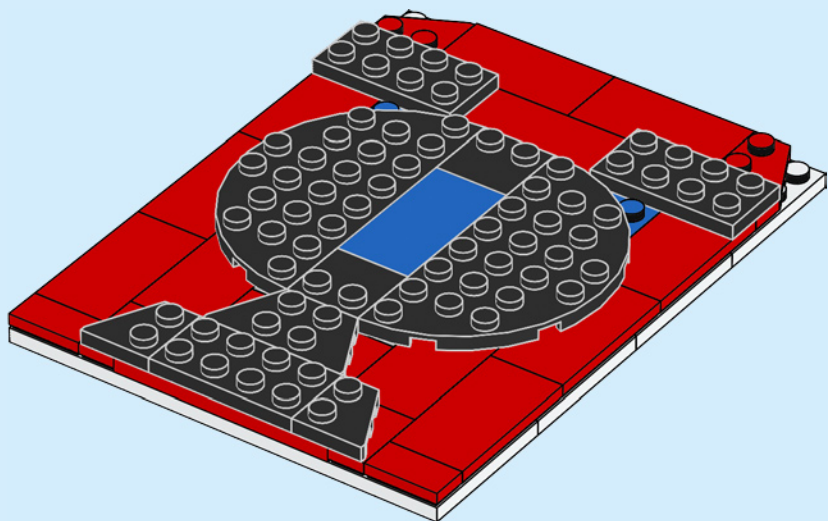

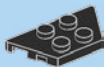

1x

15

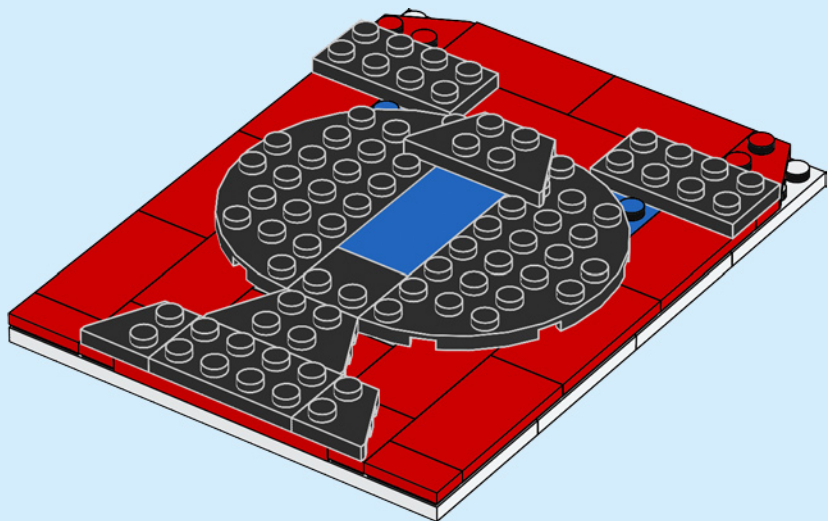

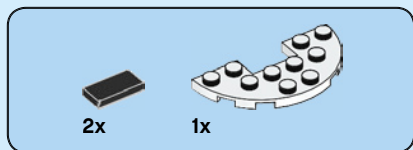

16

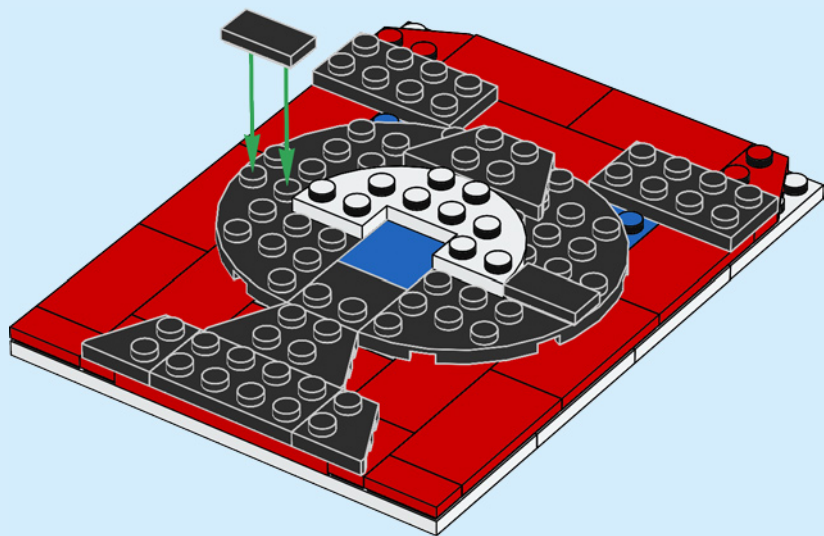

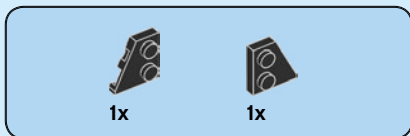

17

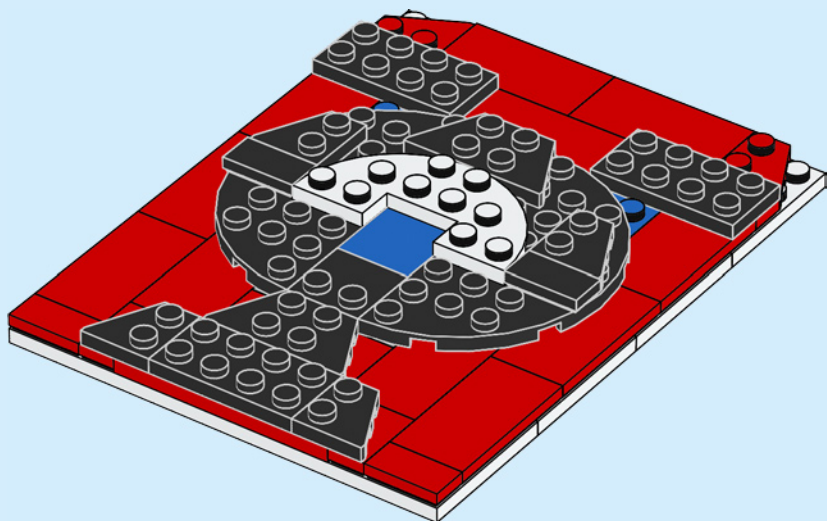

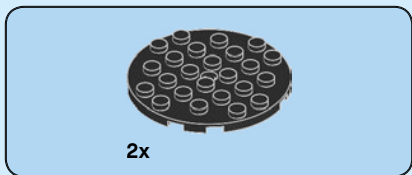

18

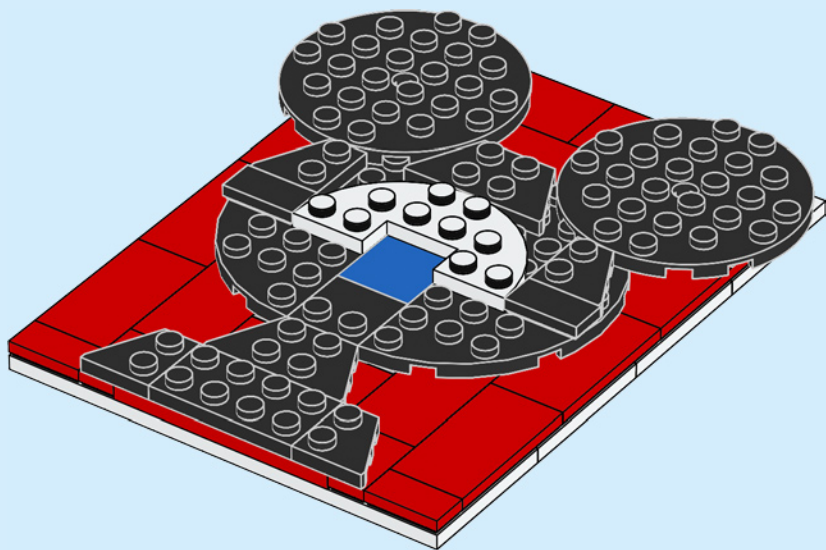

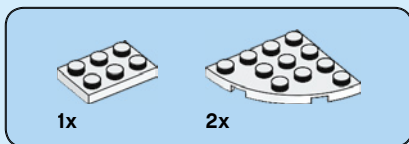

19

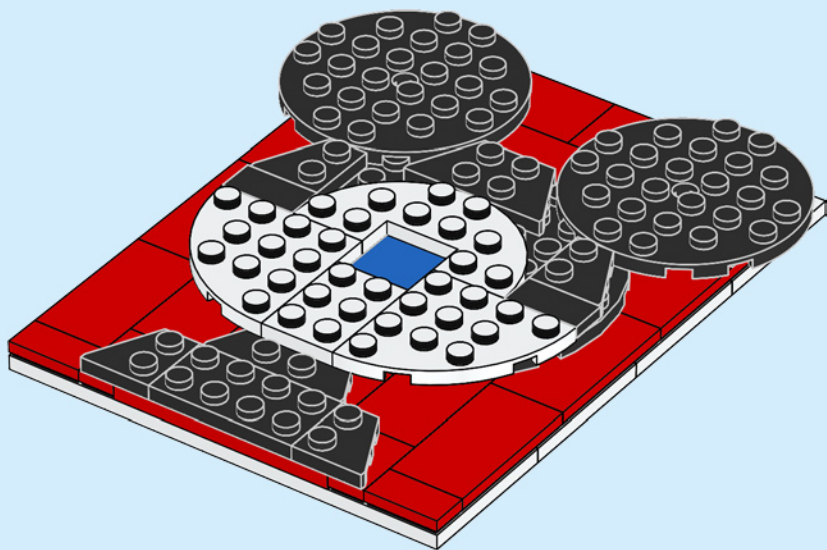

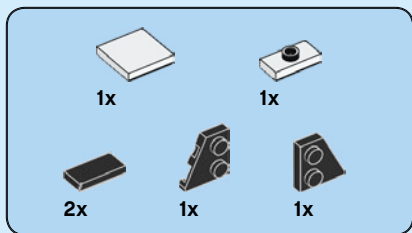

20

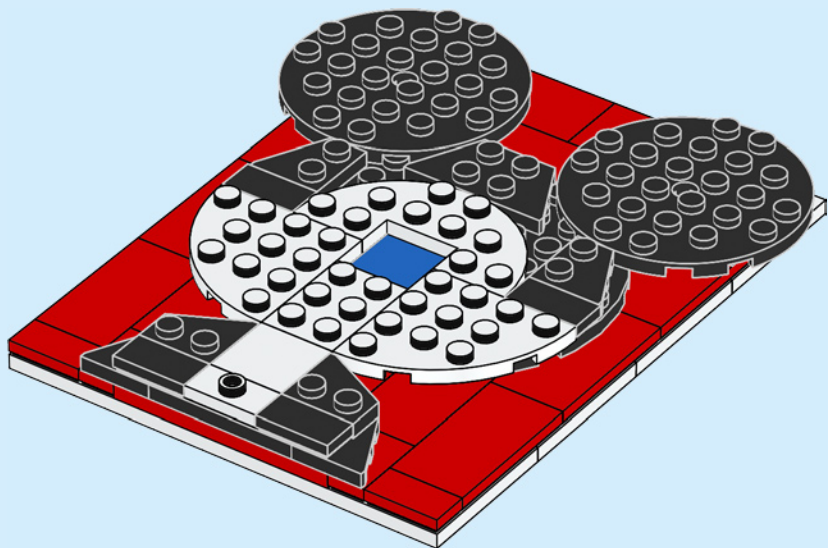

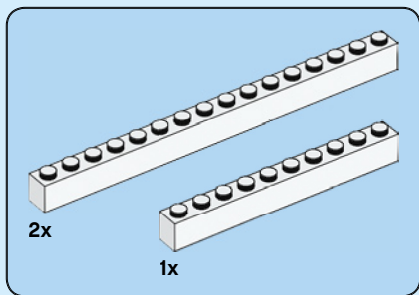

21

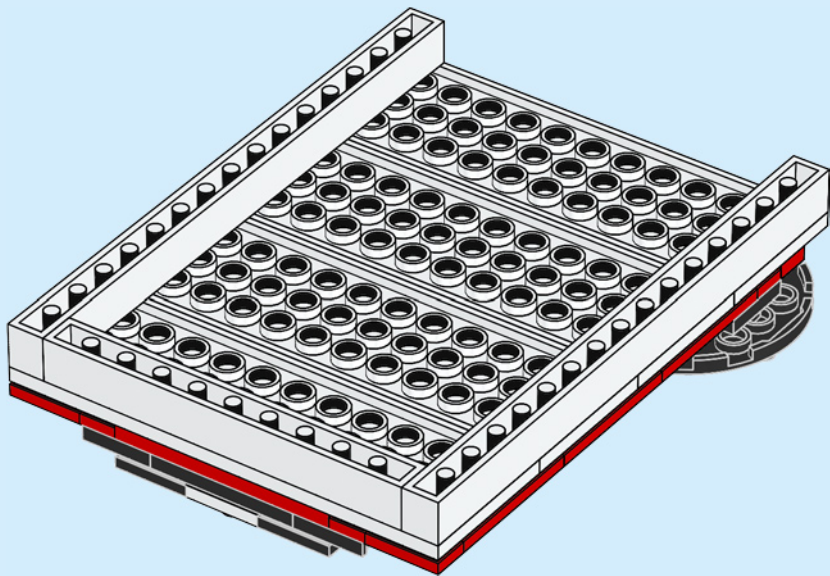
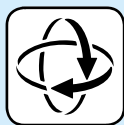

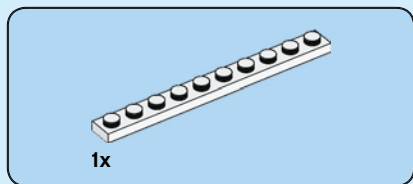

22

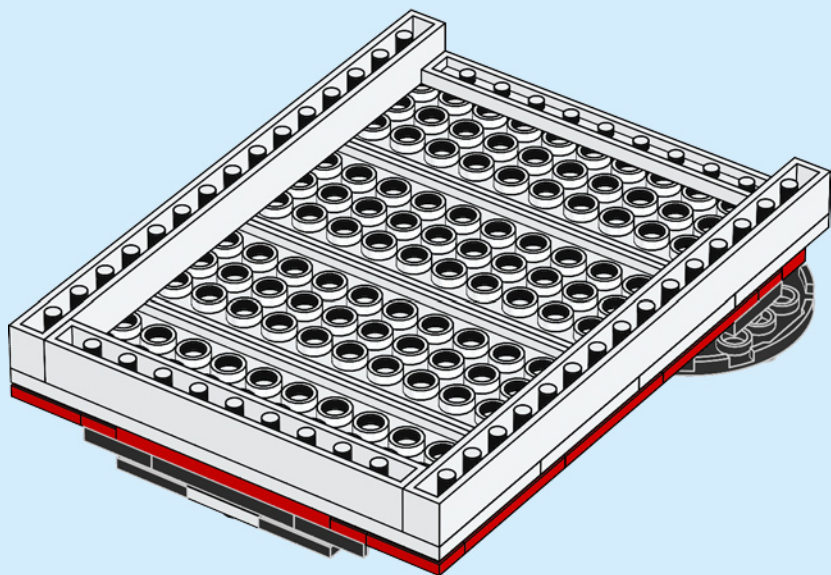



2x



1x

23

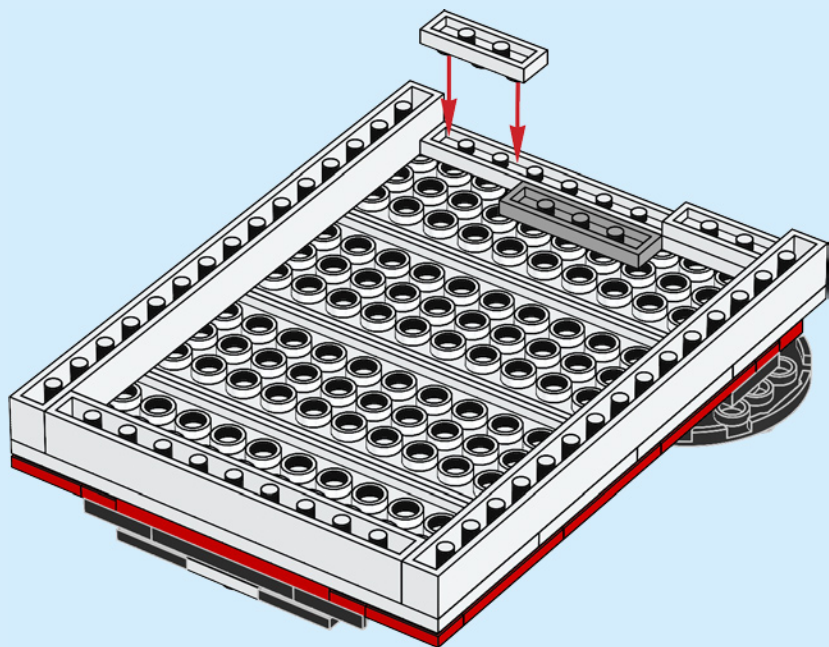



1x



2x

24

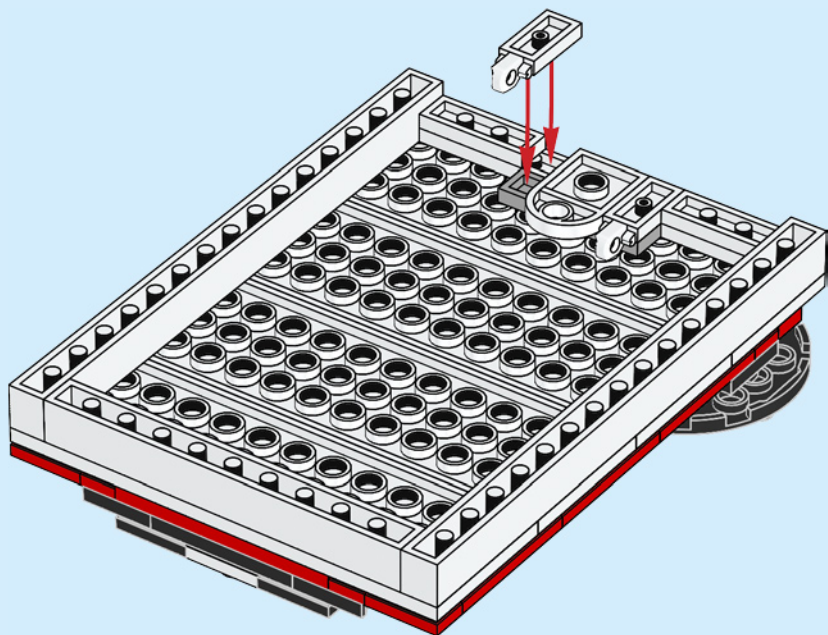

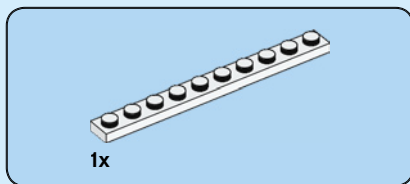

25

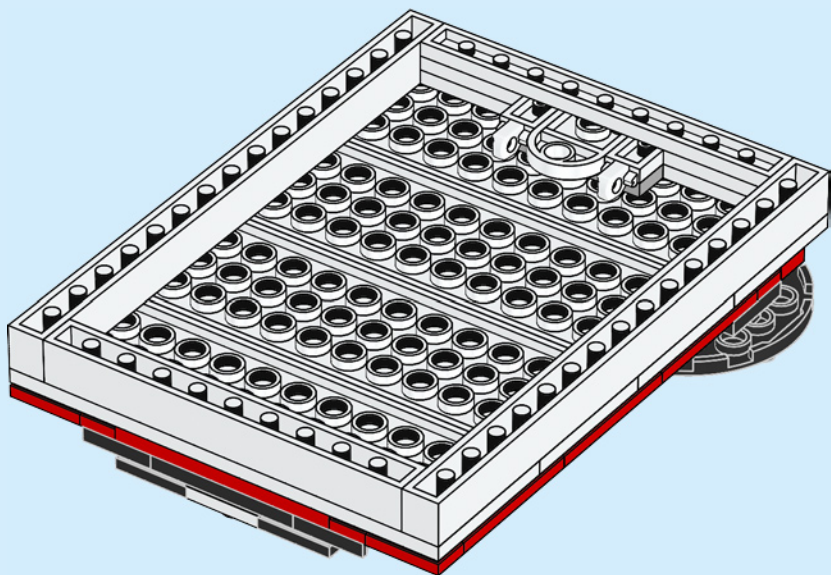

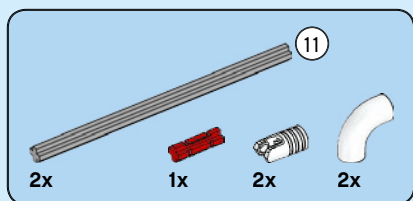

26

1

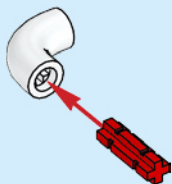

2



3

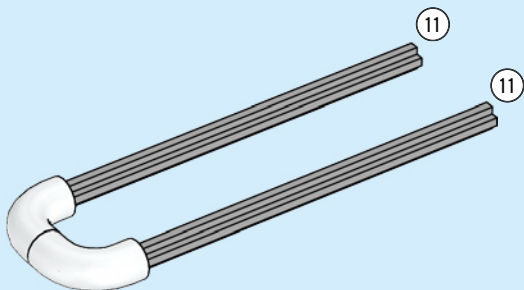



11

1:1

4

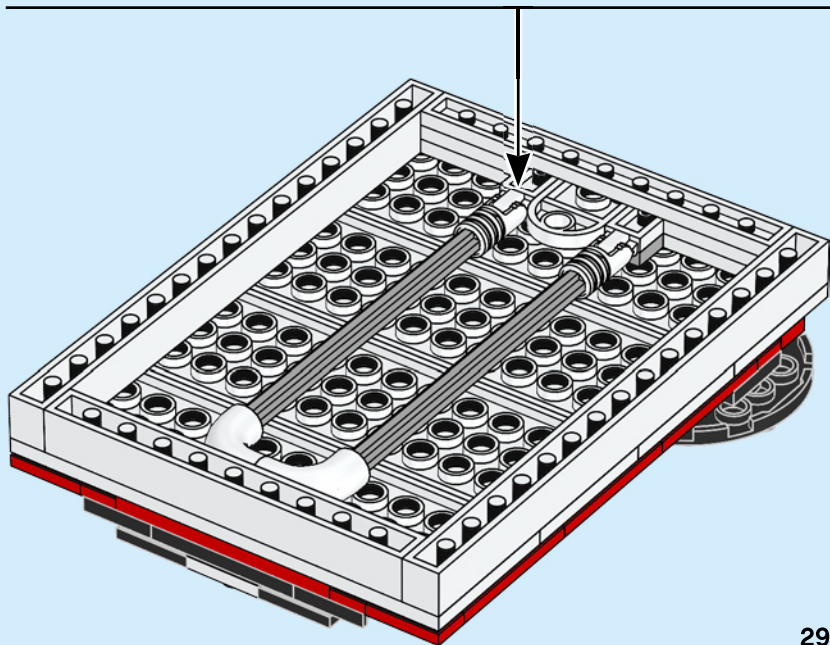
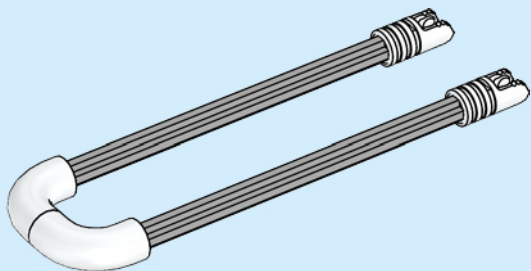



4x

27

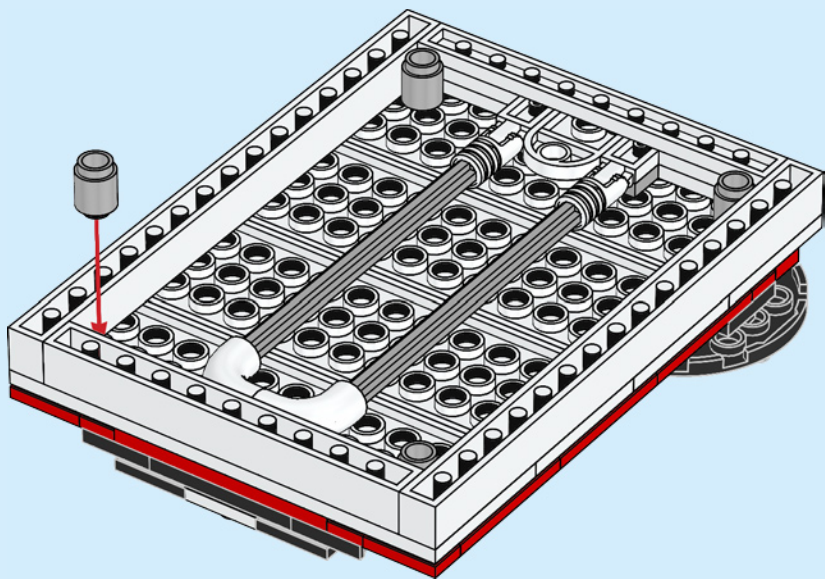



4x

28

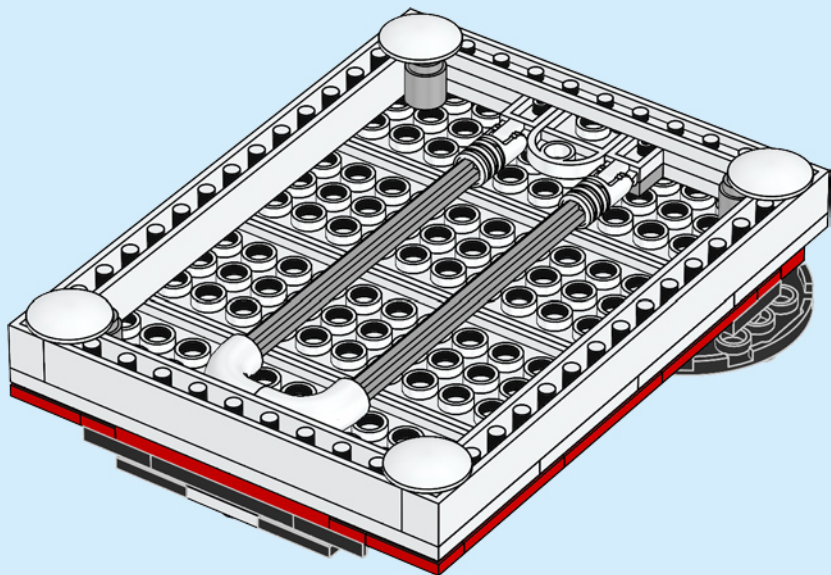

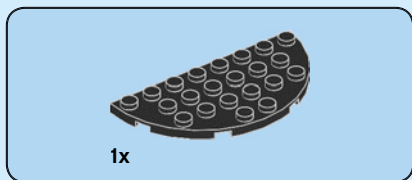

29

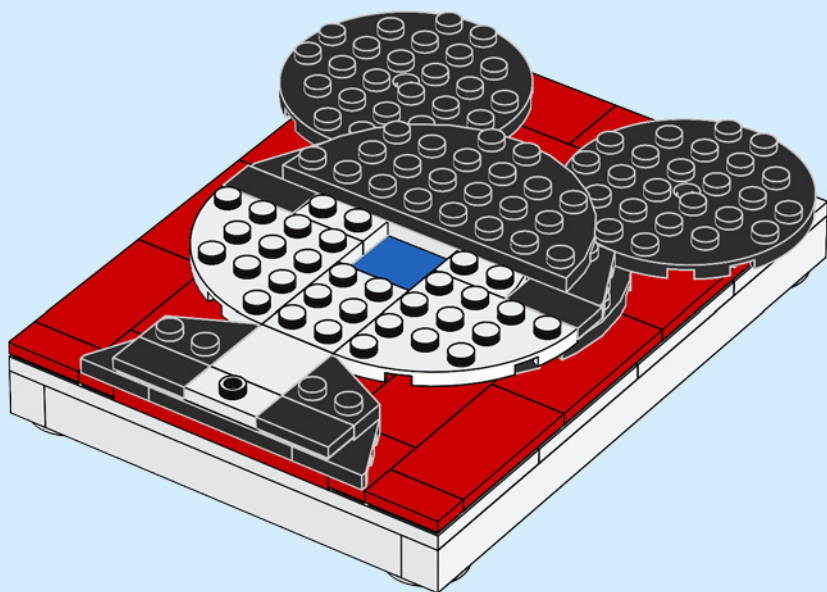

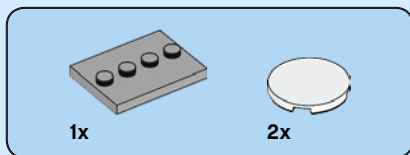

30

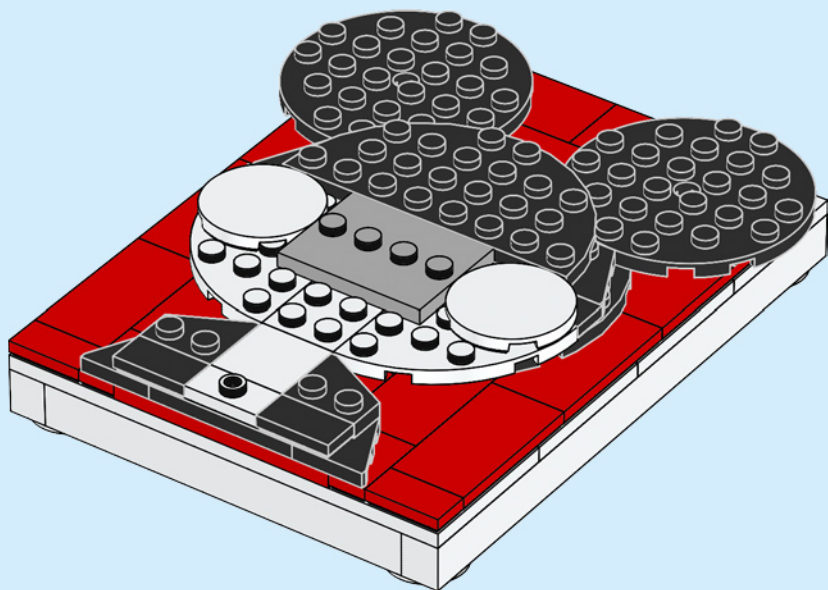

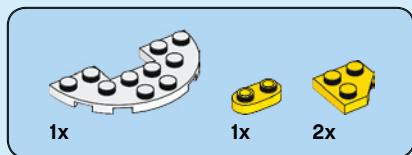

31

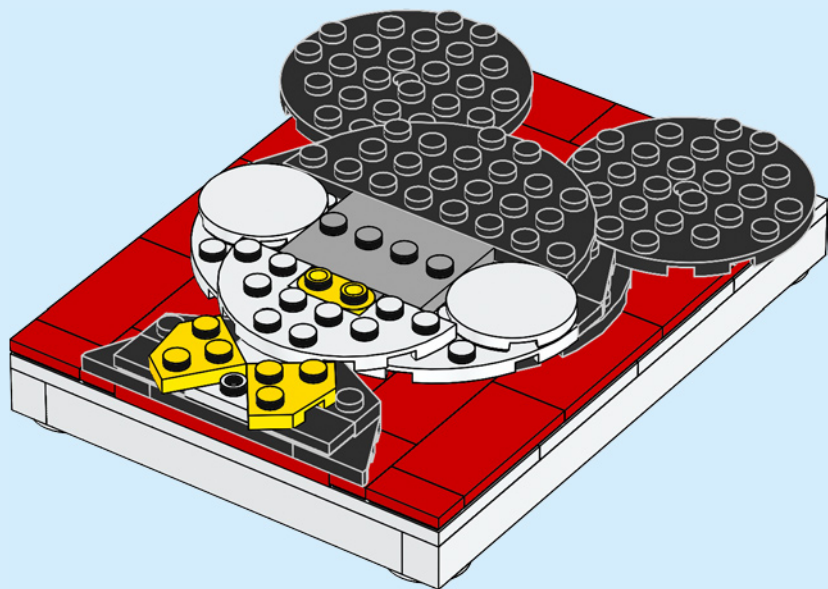

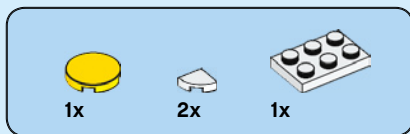

32

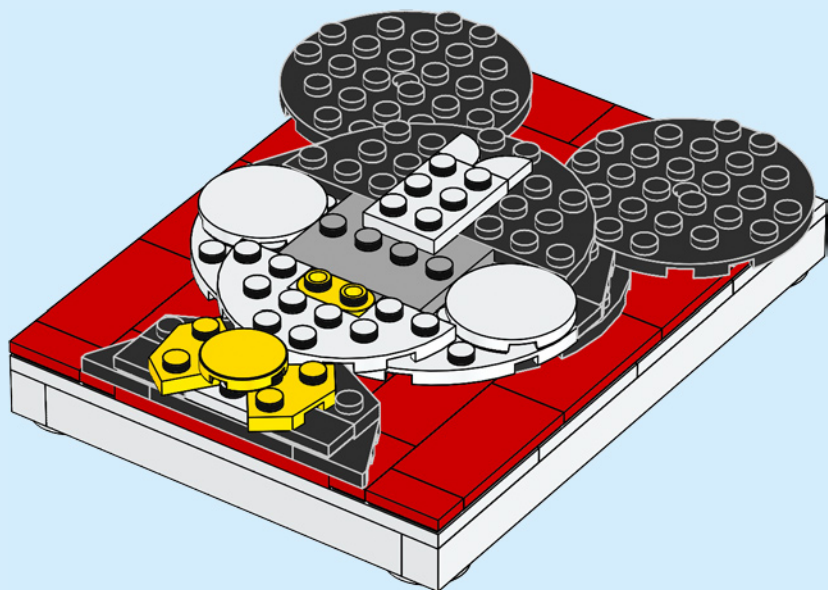

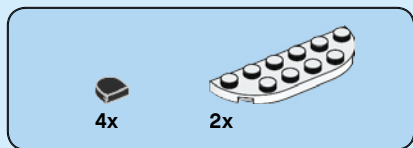

33

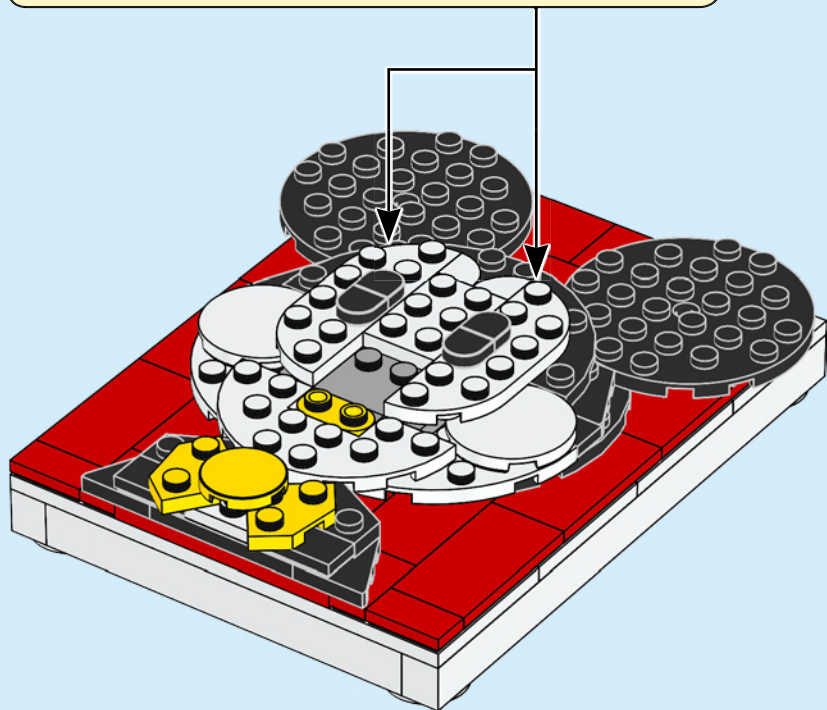
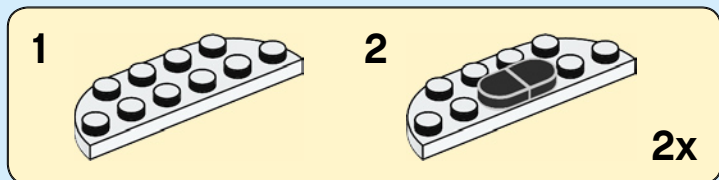



1x



2x



1x

34

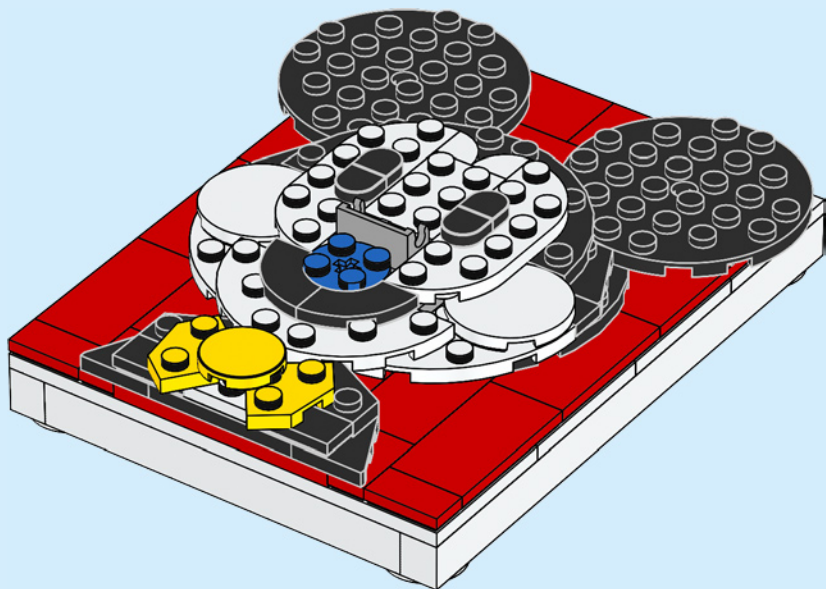

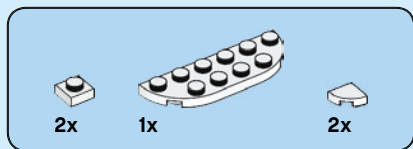

35

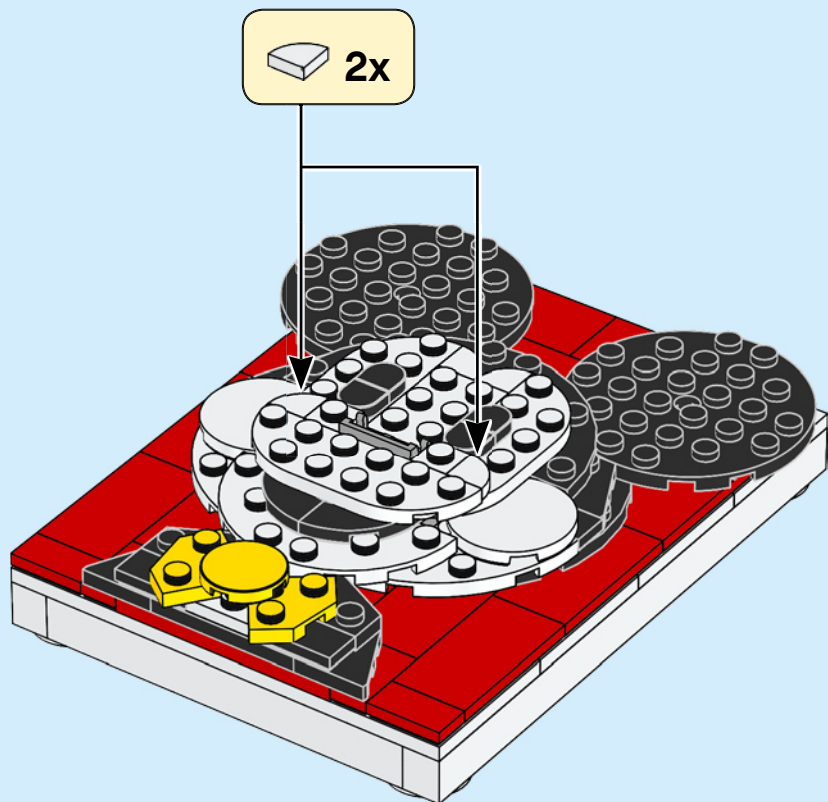

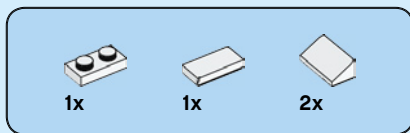

36

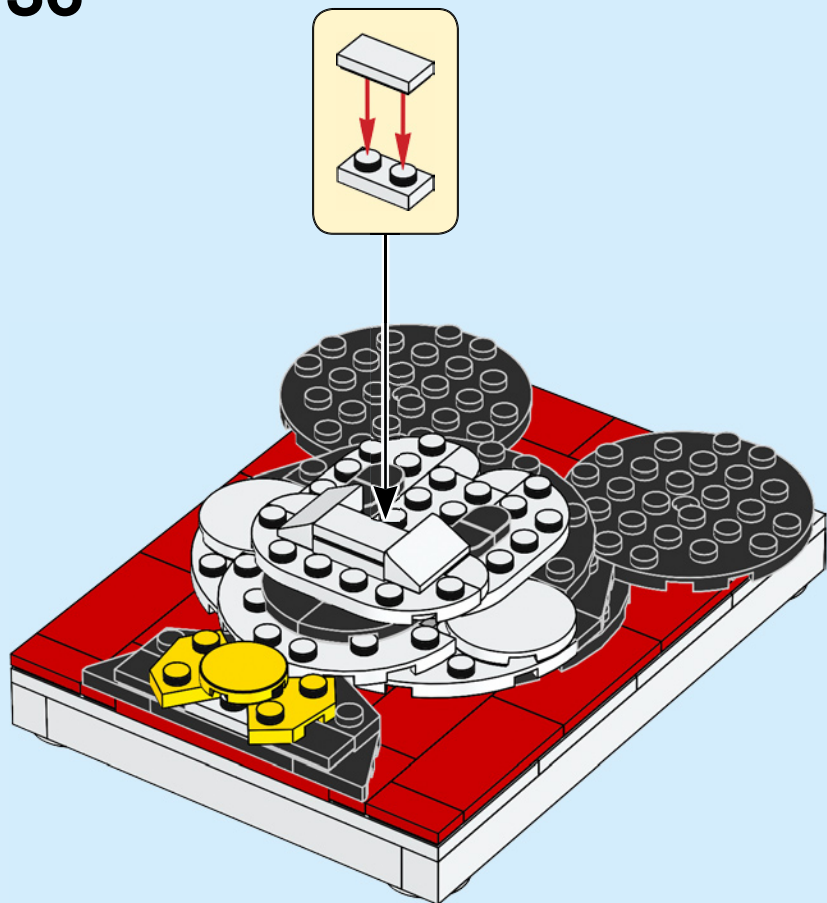

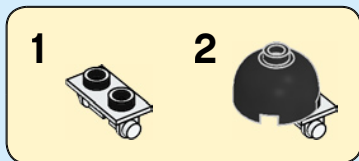
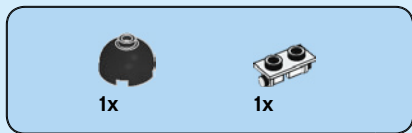

37

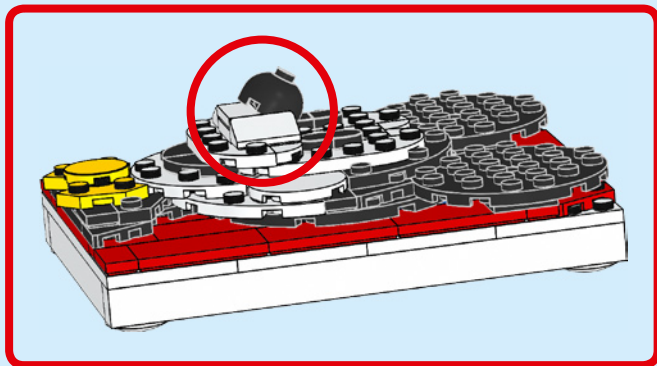
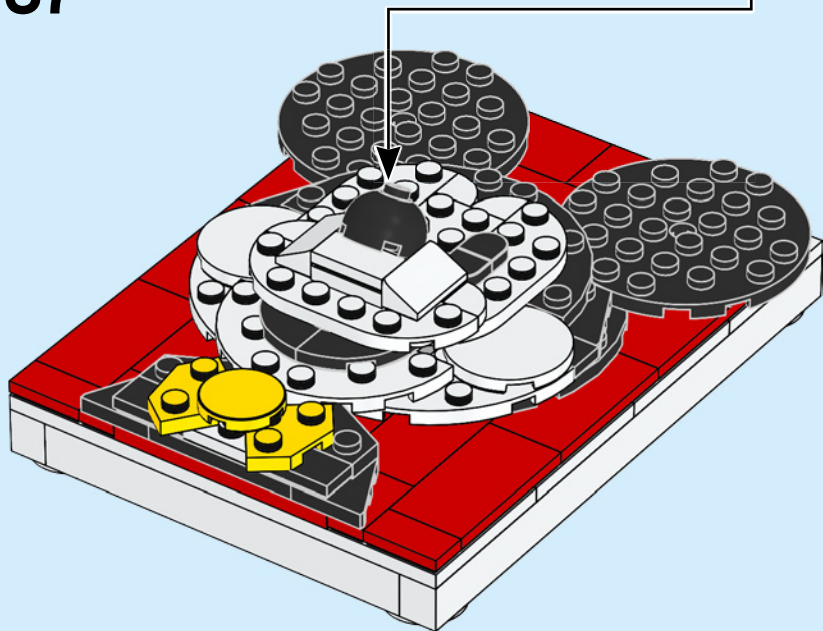

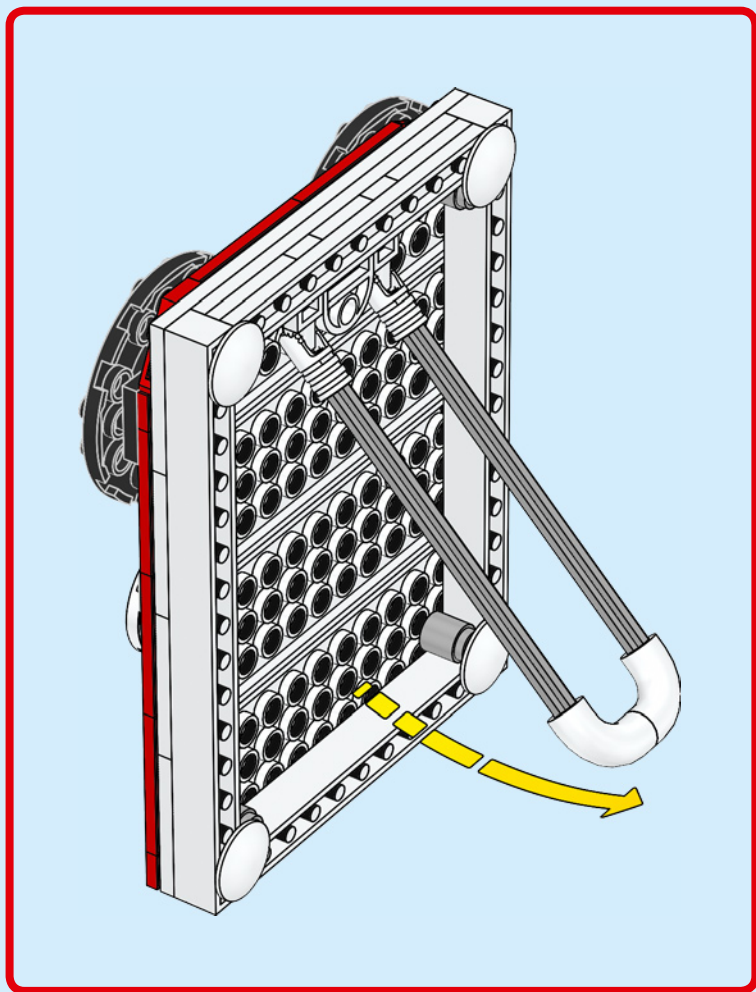

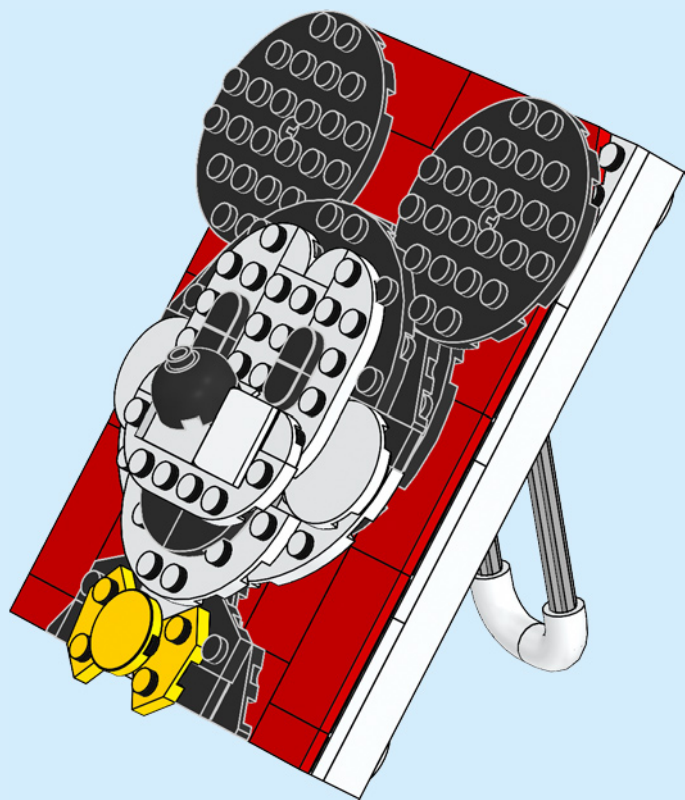

2x 302401
 4x 6172366
 2x 4547489
 4x 4278271
 2x 6194851
 2x 6271540
 1x 6051511
 1x 393801
 1x 302301
 1x 306901
 2x 6266219
 1x 306801
 2x 6300017
 2x 362301
 1x 6089696

2x 302101
 3x 6147792
 2x 6192352
 2x 4178429
 1x 611101
 2x 447701
 4x 4168072
 2x 246501
 2x 6178172
 1x 383224
 2x 303423

11

2x 6141553
 1x 4142865
 8x 306921
 11x 4560179
 1x 379521
 1x 6248971
 1x 6078279
 2x 6195184
 2x 6187587
 3x 6133200

2x 6192346
 2x 6191630
 2x 4531412
 3x 302026
 1x 403223
 1x 4560180
 1x 4211445
 1x 6079461
 2x 4211481

4x 6256435
 3x 6141554
 3x 6141556
 1x 4216660
 4x 306926
 4x 4211412
 1x 4211469



Customer Service
Kundenservice
Service Consommateurs
Servicio Al Consumidor
LEGO.com/service or dial

: 00800 5346 5555
 : 1-800-422-5346

WIN

GO TO WWW.LEGO.COM/PRODUCTFEEDBACK
AND GIVE US YOUR SHORT **FEEDBACK**
ABOUT THIS LEGO® SET FOR A CHANCE
TO WIN A COOL LEGO PRIZE.

Terms & Conditions apply



LEGO.com/productfeedback

GEWINNE

Erzähle uns auf
www.LEGO.com/productfeedback

etwas über die Erfahrungen, die du mit
diesem LEGO® Set gemacht hast, und
sichere dir die Chance auf einen coolen
LEGO Preis!

Es gelten die Teilnahmebedingungen

获取奖品

登录
www.LEGO.com/productfeedback

给出关于此乐高®套装的简短反馈，
就有机会获得炫酷乐高奖品

《条款及条件》适用

GAGNE

Rends-toi sur
www.LEGO.com/productfeedback

et donne-nous quelques commentaires
sur ce produit LEGO® pour avoir une
chance de gagner un prix LEGO !

Voir Conditions Générales

경품 당첨 기회

www.LEGO.com/productfeedback

페이지로 이동하여 이 레고® 세트에 대한
간략한 피드백을 보내 주시고 멋진 레고
경품을 탈 수 있는 기회도 잡으십시오

약관 적용

GANA

Visita
www.LEGO.com/productfeedback

y envíanos tu opinión acerca de este
set LEGO®. ¡Participarás en el sorteo
de un premio LEGO!

Términos y Condiciones aplicables

ЗАПОЛНИ АНКЕТУ И ПОЛУЧИ ПРИЗ

Перейди по ссылке
www.LEGO.com/productfeedback

ответь всего на несколько во-
просов об этом наборе LEGO®,
и у тебя появится шанс выиграть за-
мечательный приз от компании LEGO.

Применяются Условия и правила
участия

LEGO and the LEGO logo are trademarks of the LEGO Group. ©2021 The LEGO Group.