



# CITY



**WARNING: CHOKING HAZARD.**  
Small parts. Not for children under 3 years.

3180



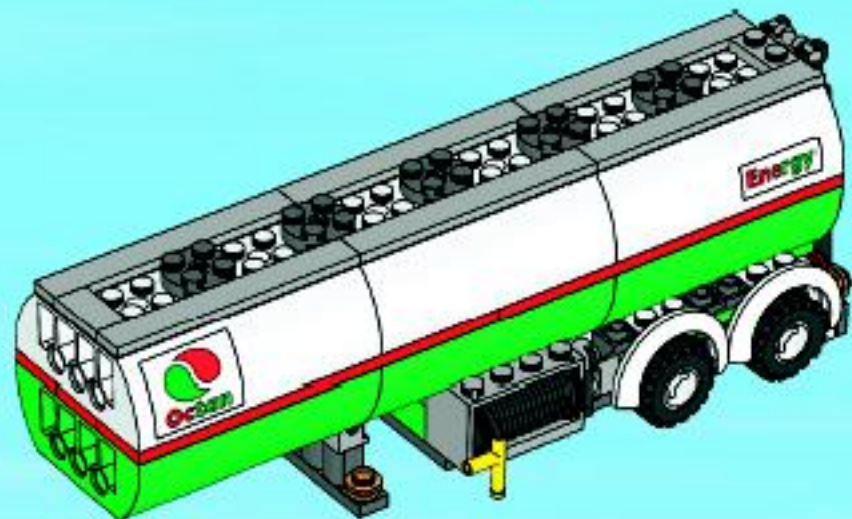

**AVERTISSEMENT : RISQUE D'ÉTOUFFEMENT.**  
Contient des petites pièces. Ne convient pas aux enfants de moins de 3 ans.



**ADVERTENCIA: PELIGRO DE ASFIXIA.**  
No recomendado para niños menores de 3 años. Contiene piezas pequeñas.

1

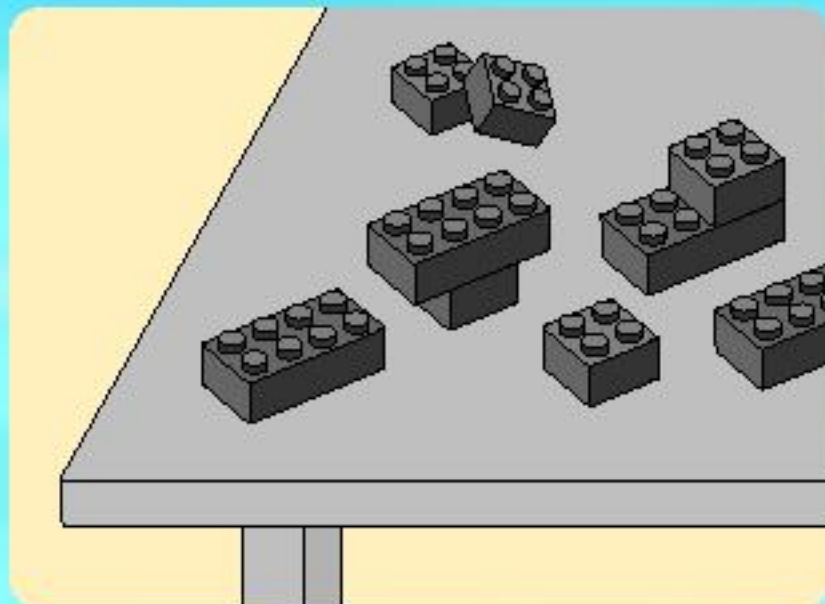

2

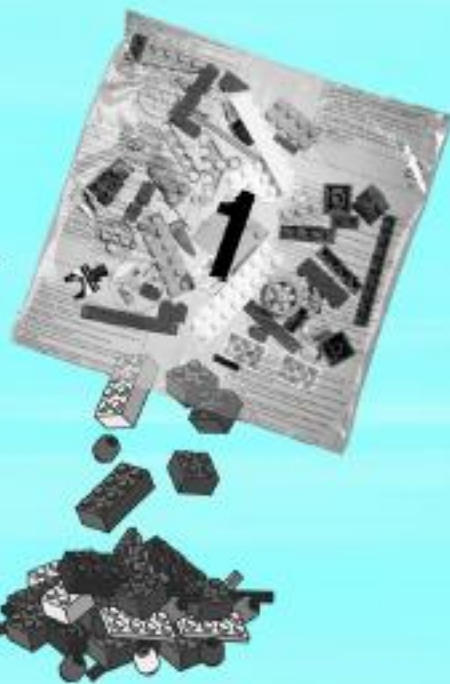

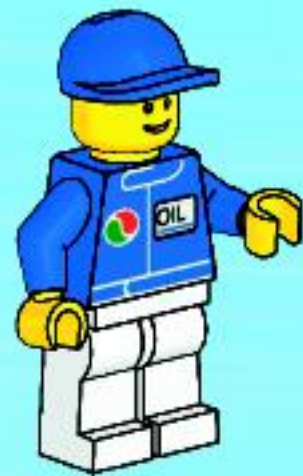
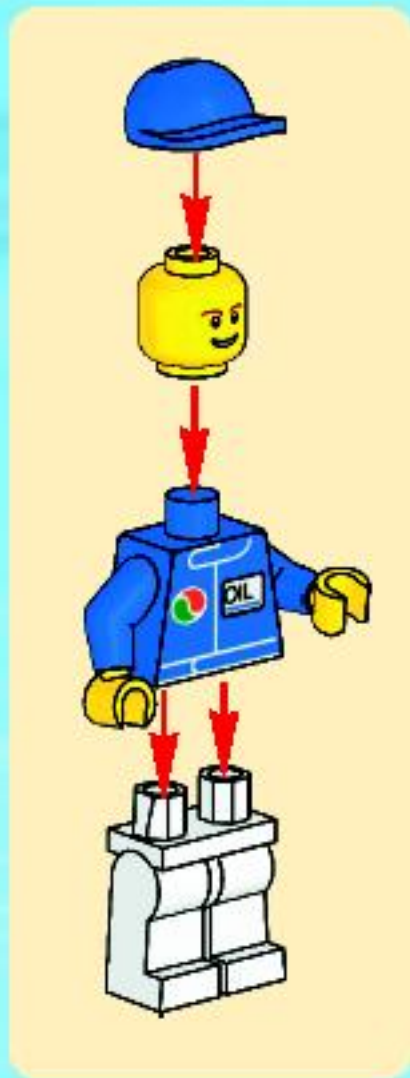

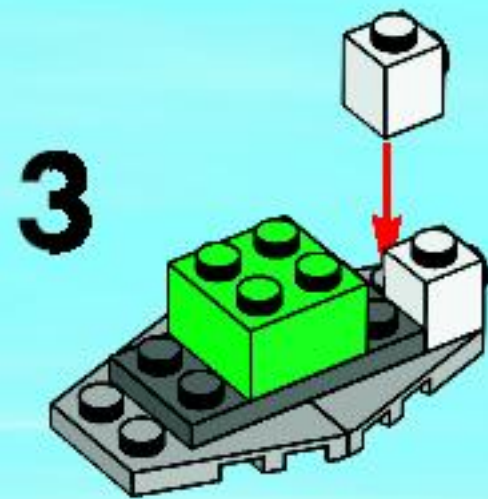
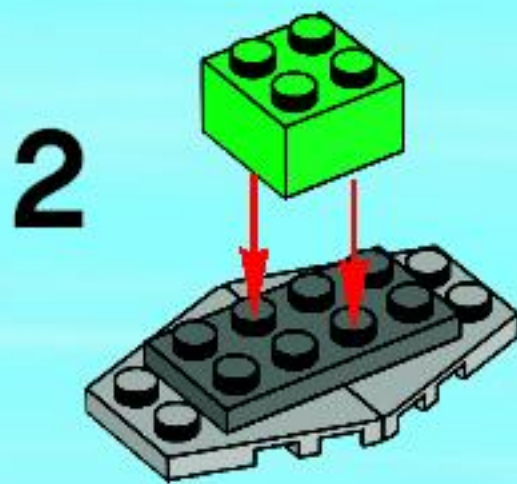
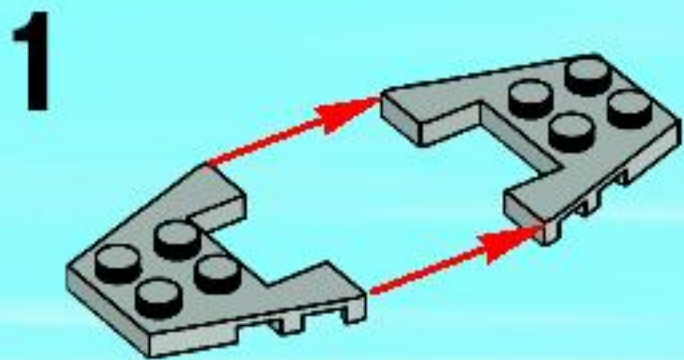

4

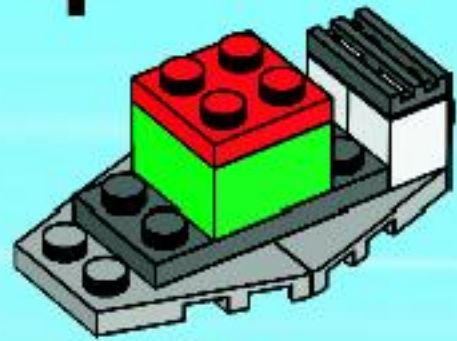

5

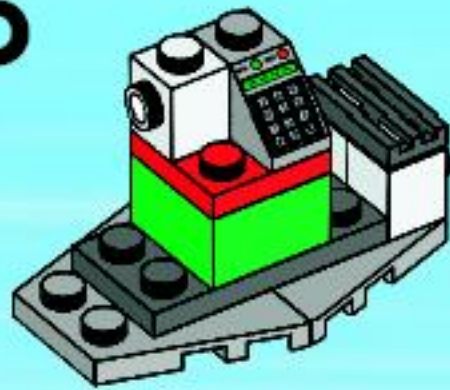

6



7



8





1

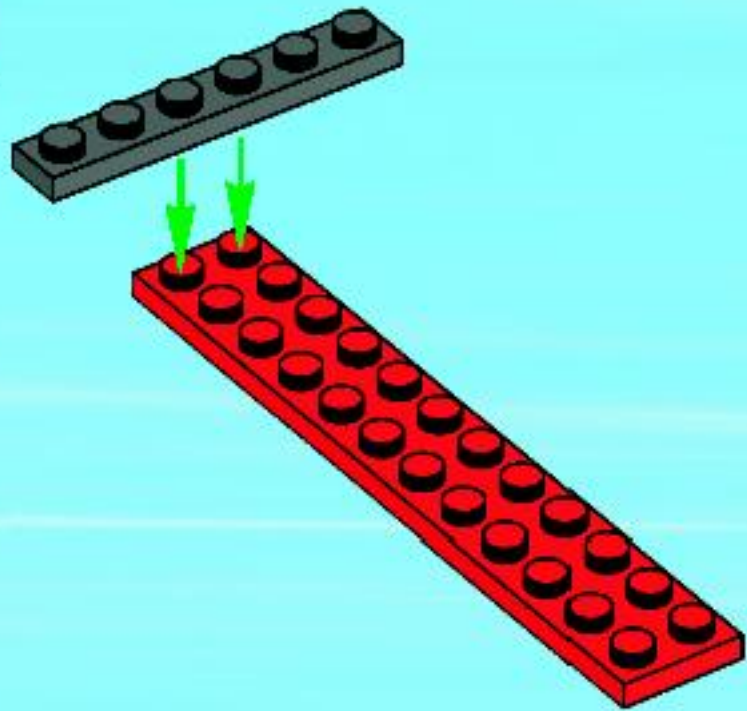

2

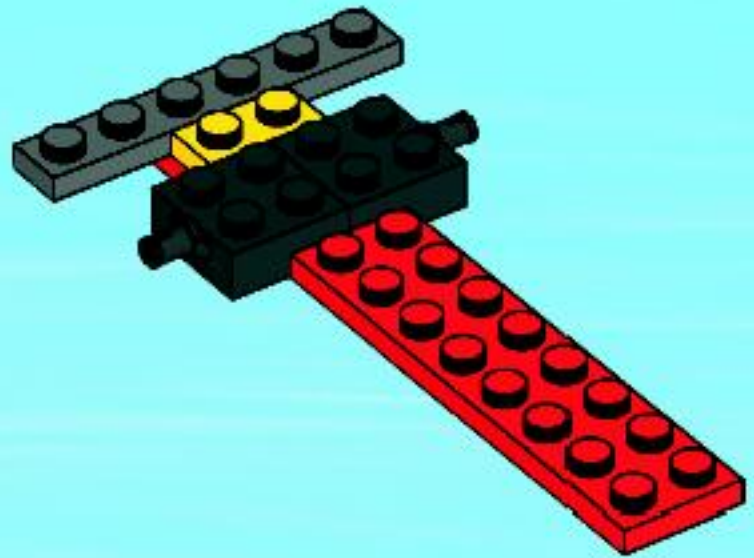



3

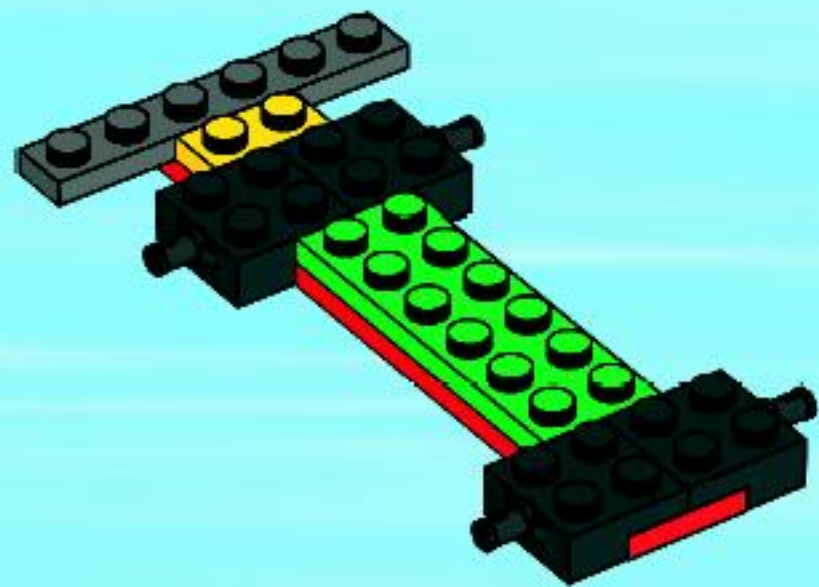

4

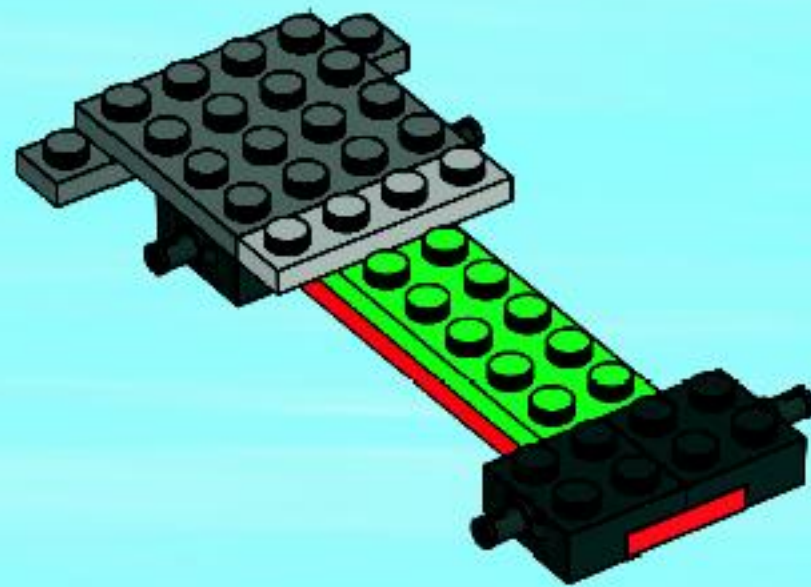

5

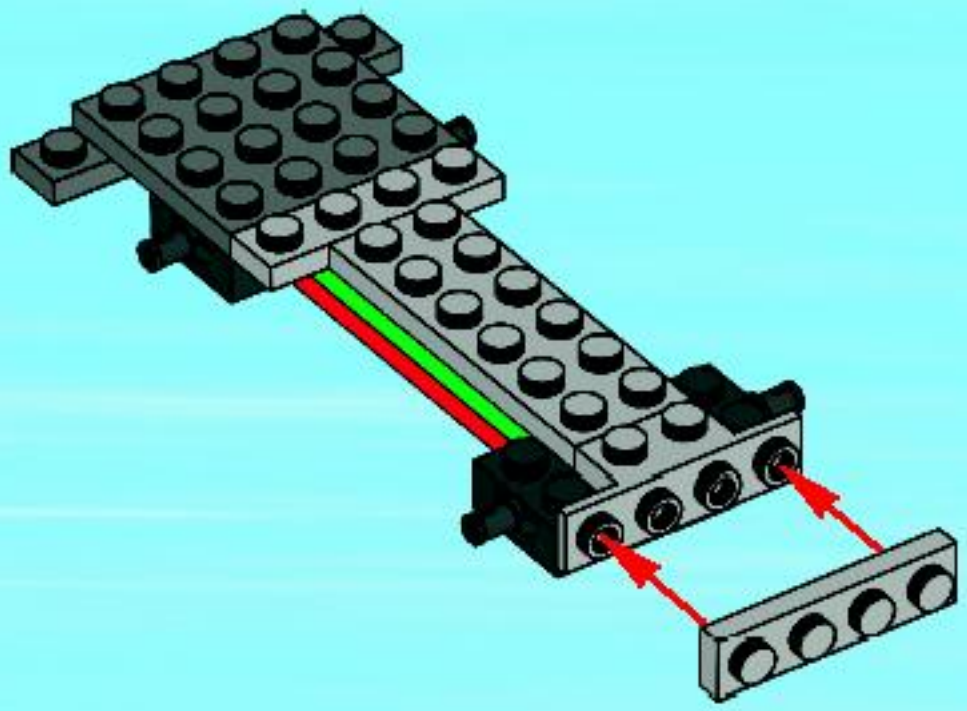

1

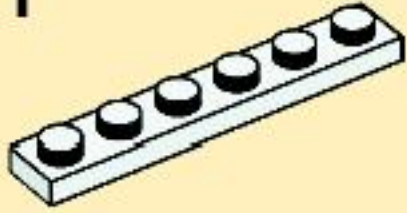

2

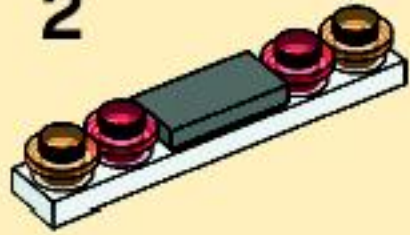

3

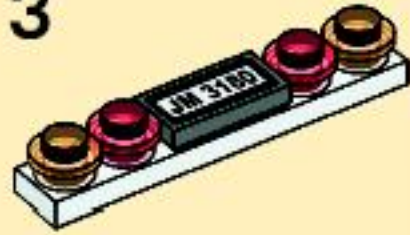

6

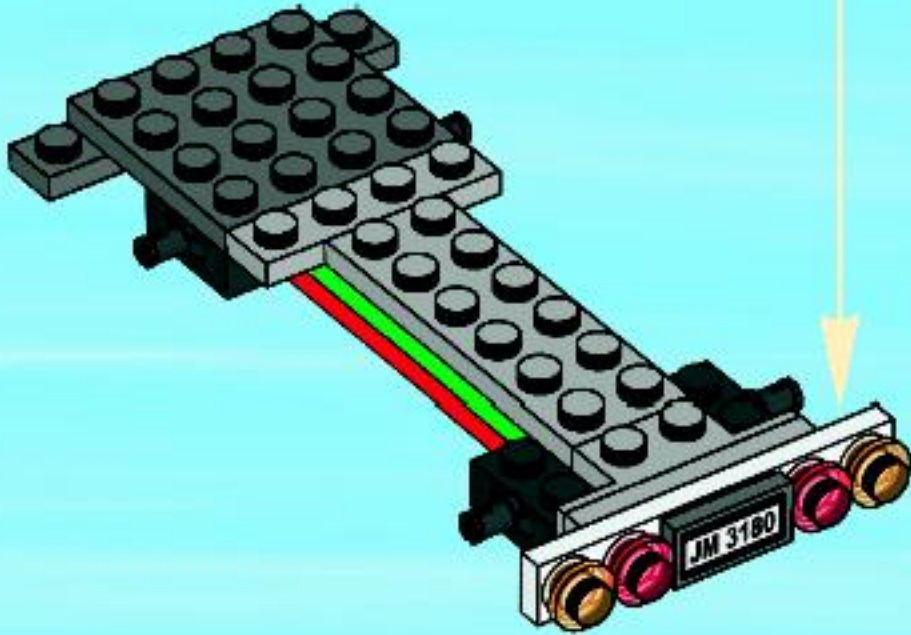

7

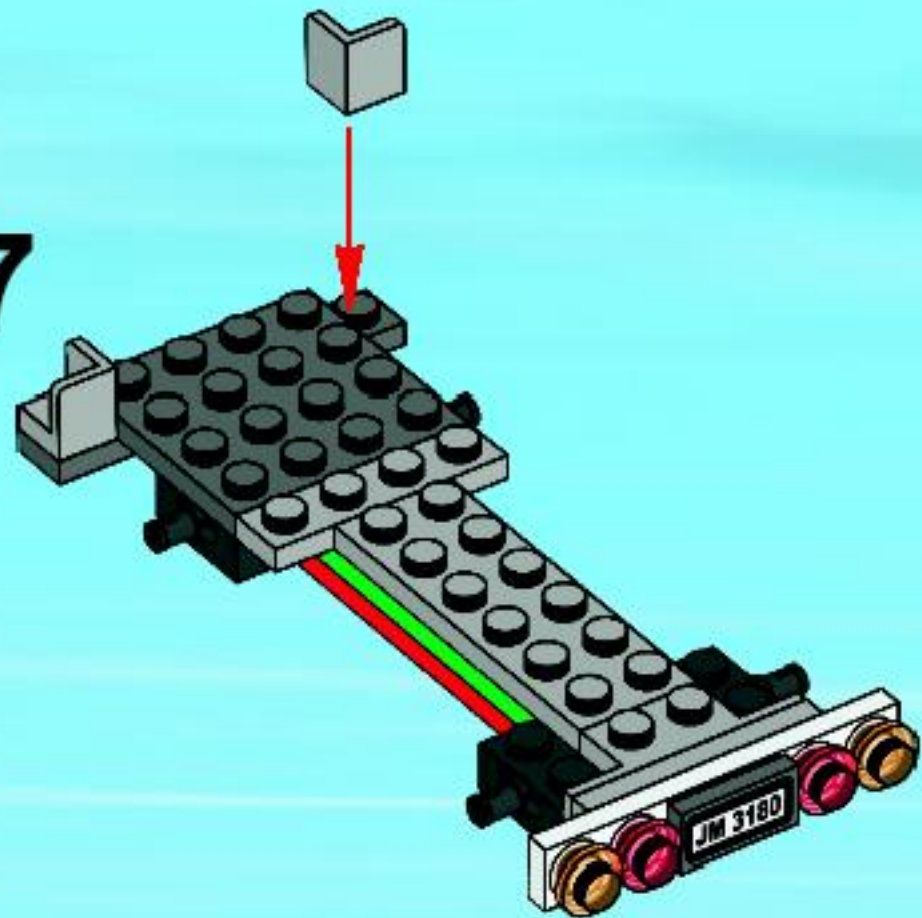

8

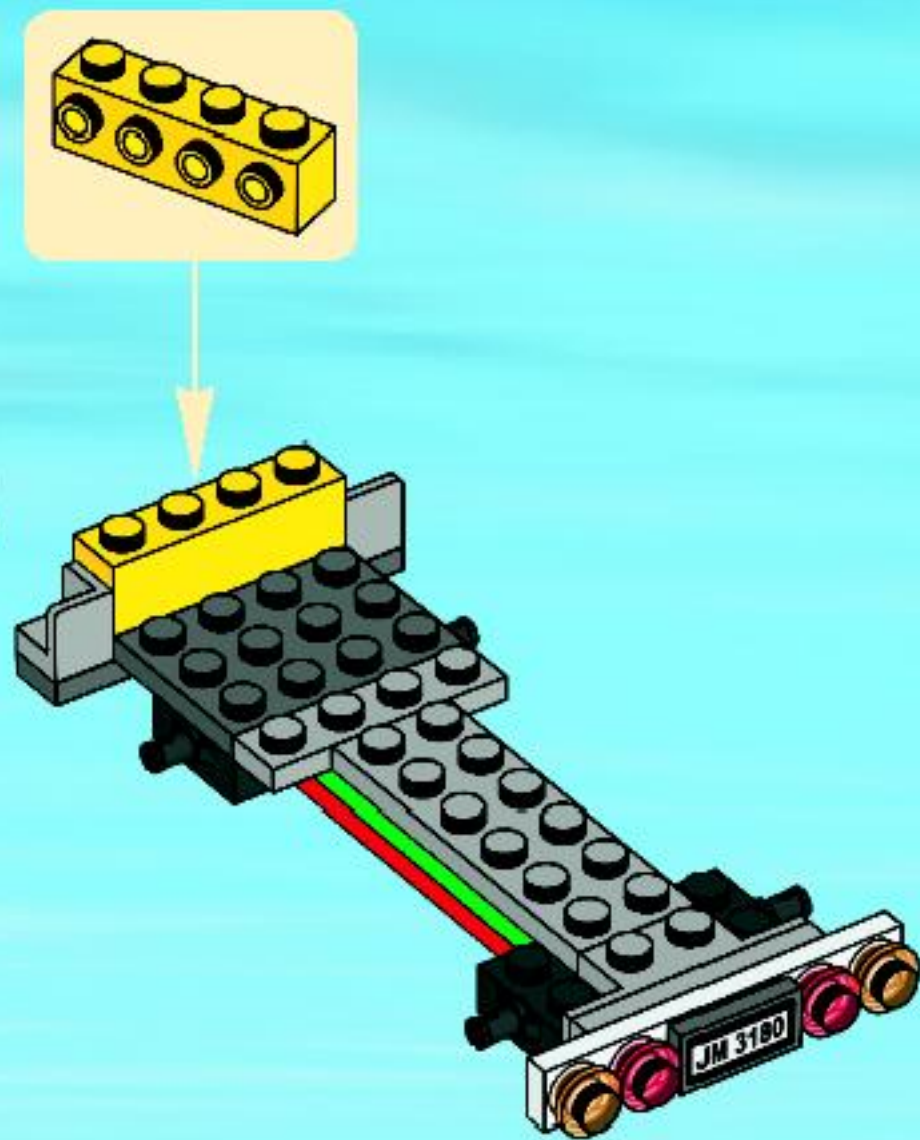

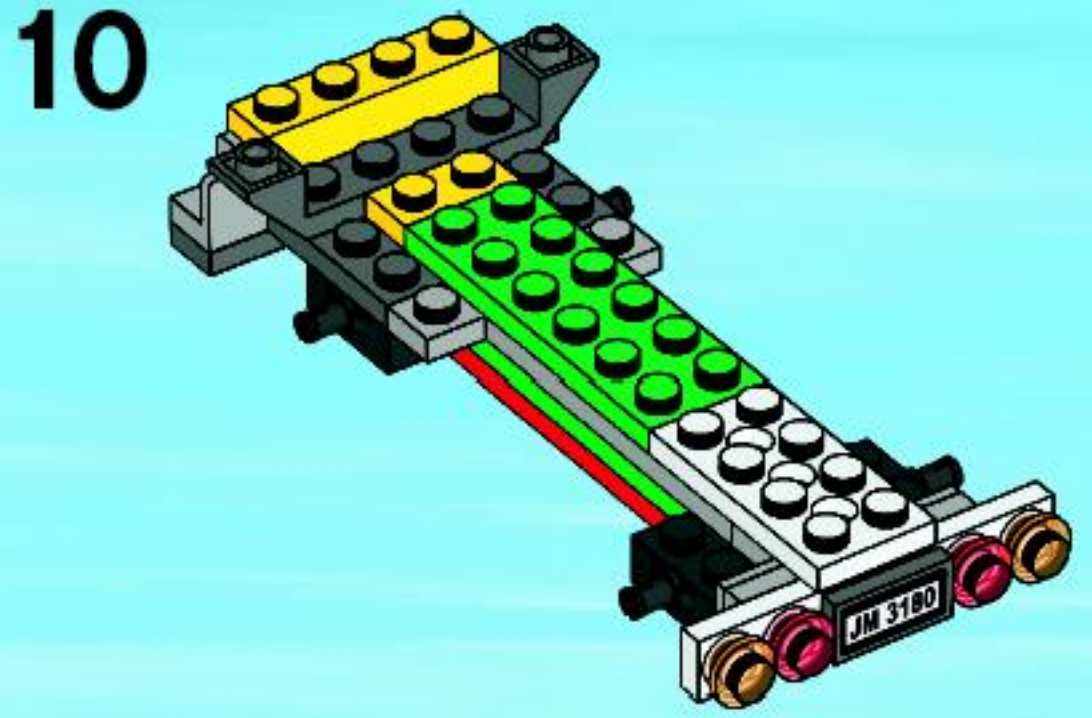
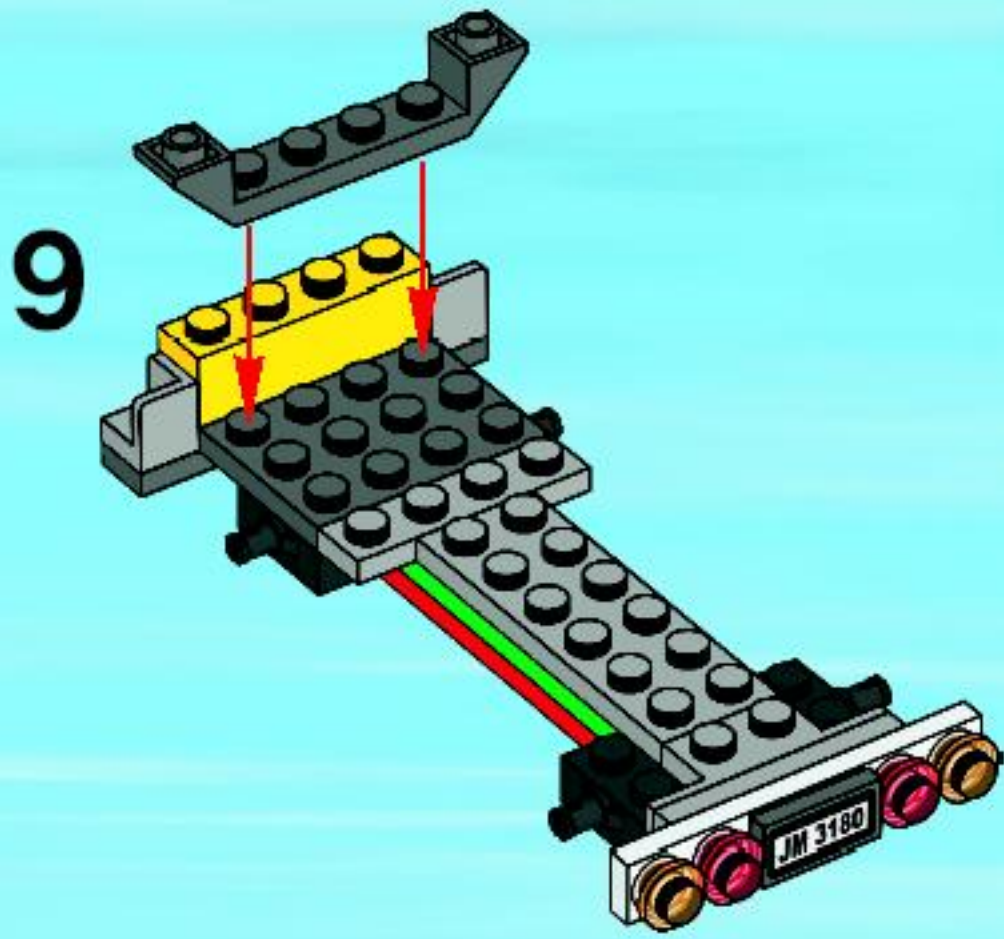

11

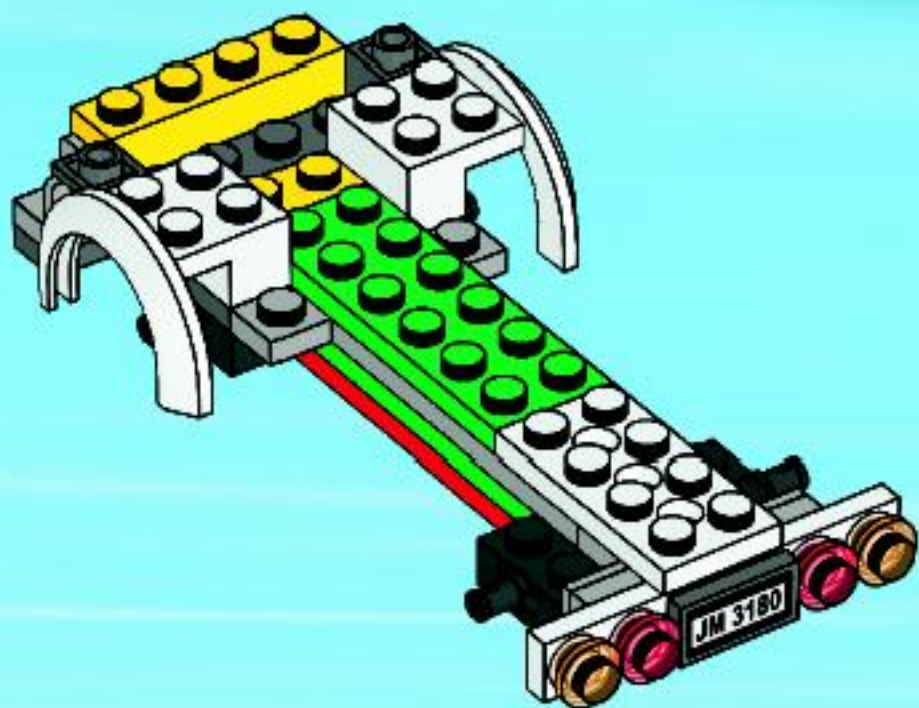

12

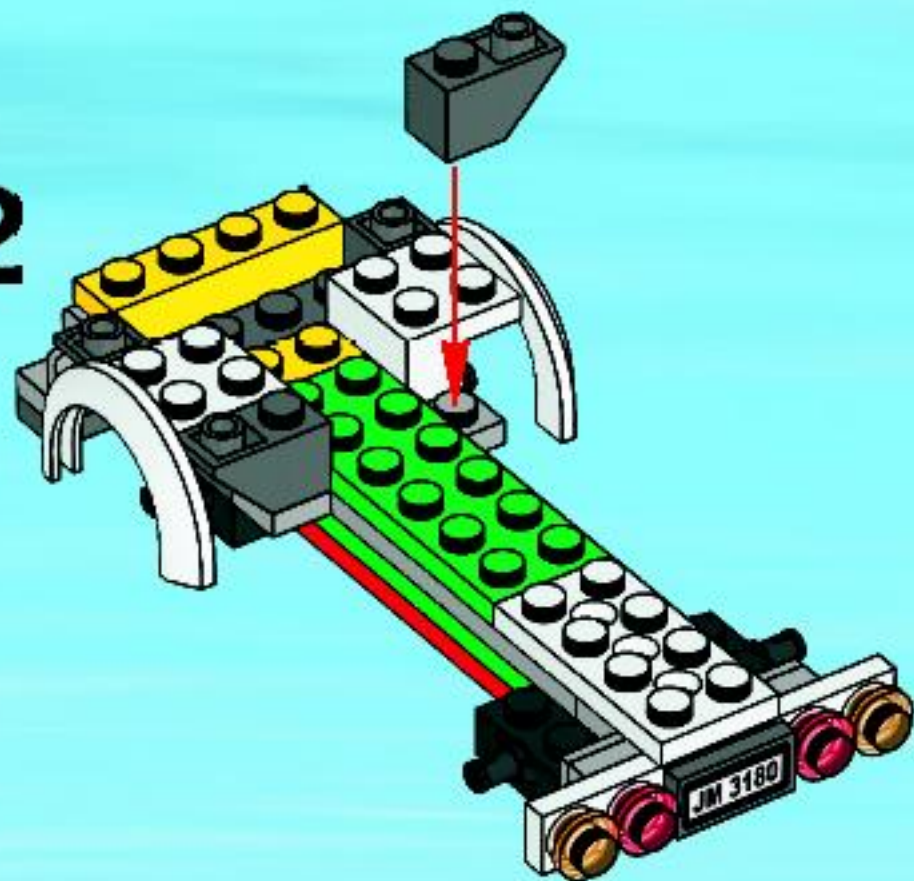

13

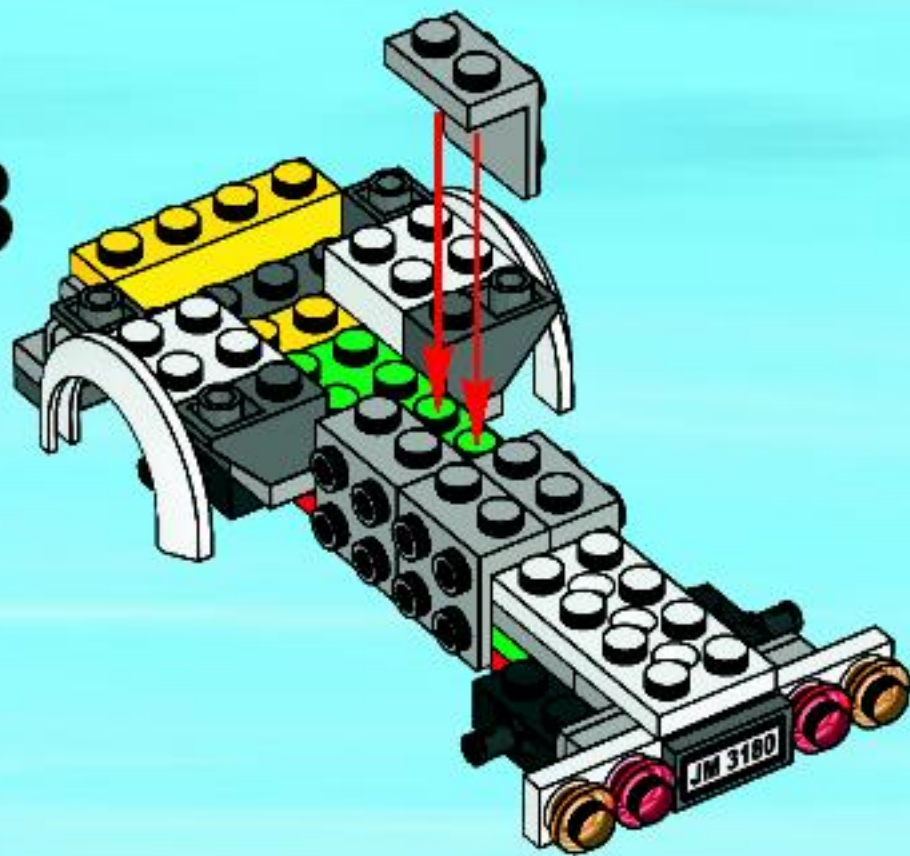

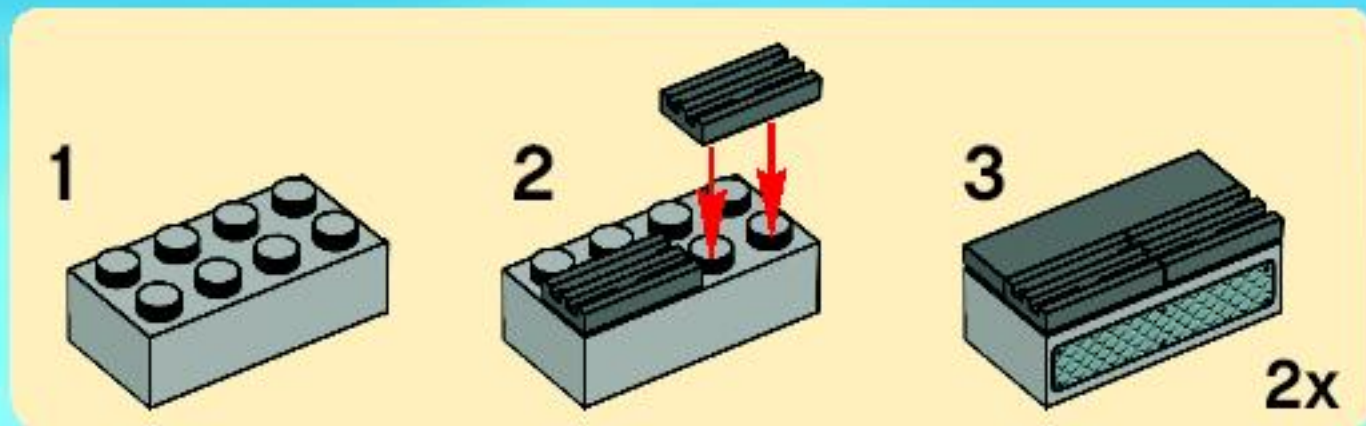

14

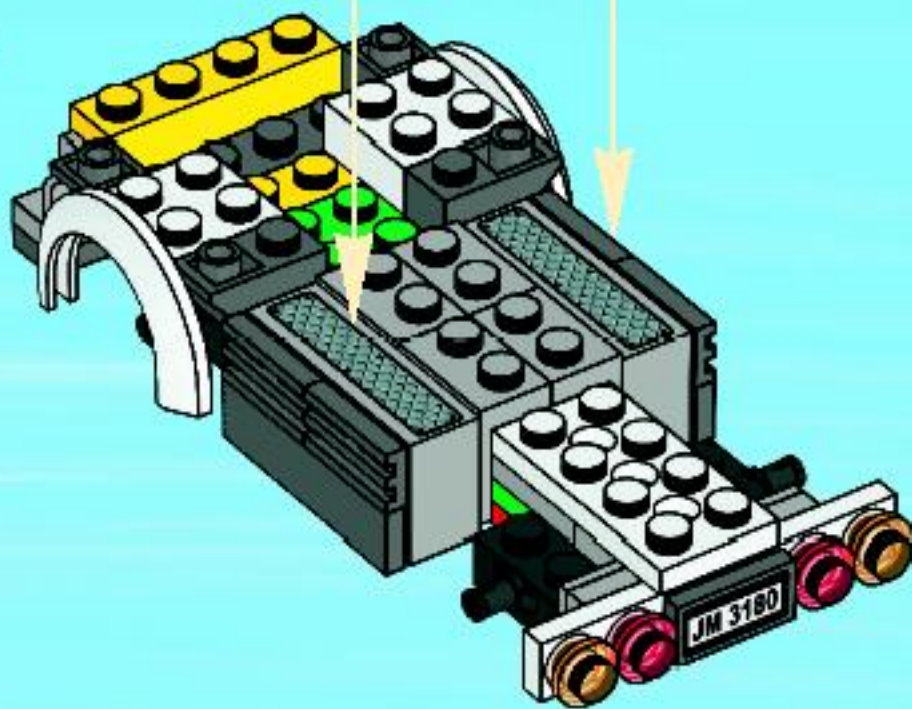



15

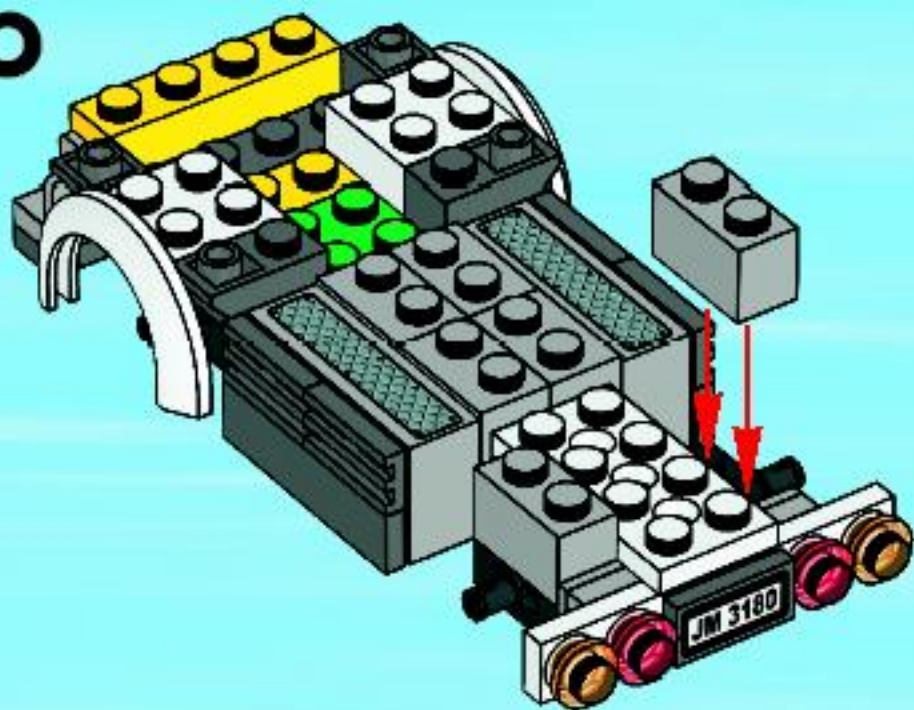

16

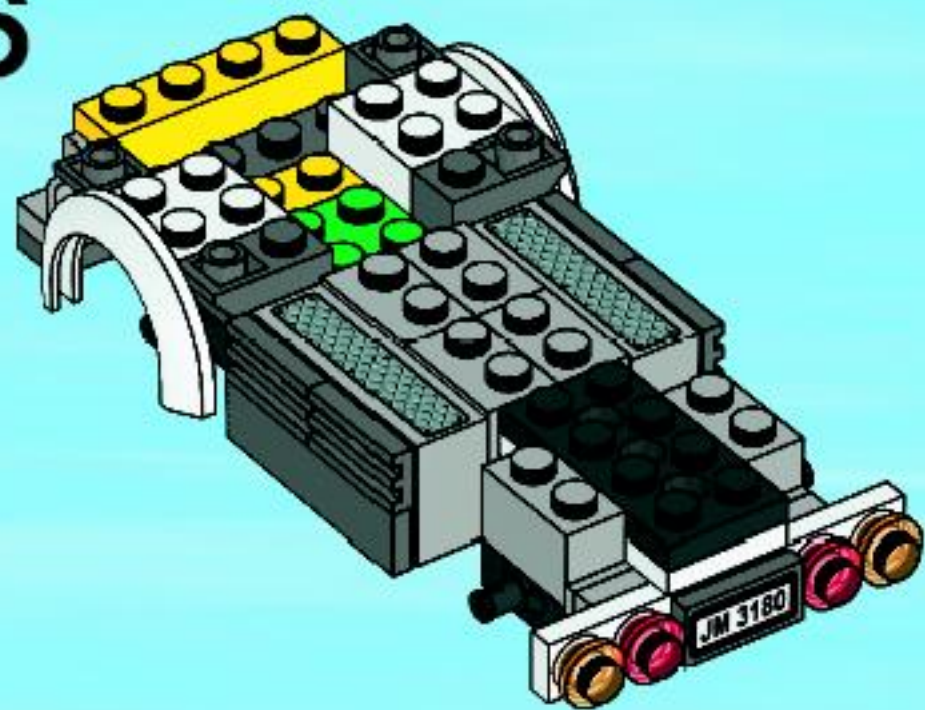

17

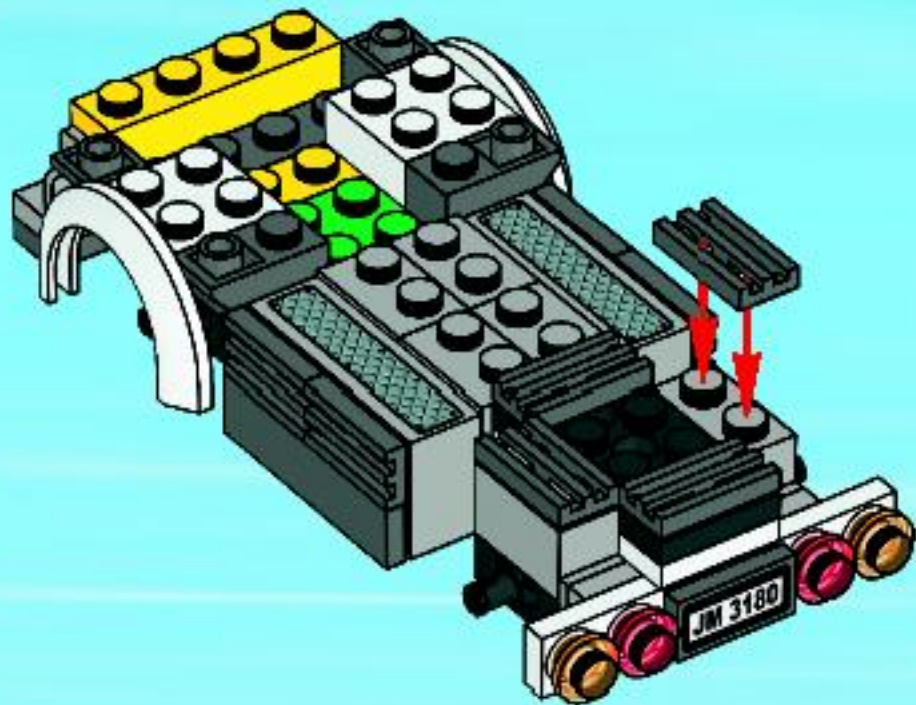

18

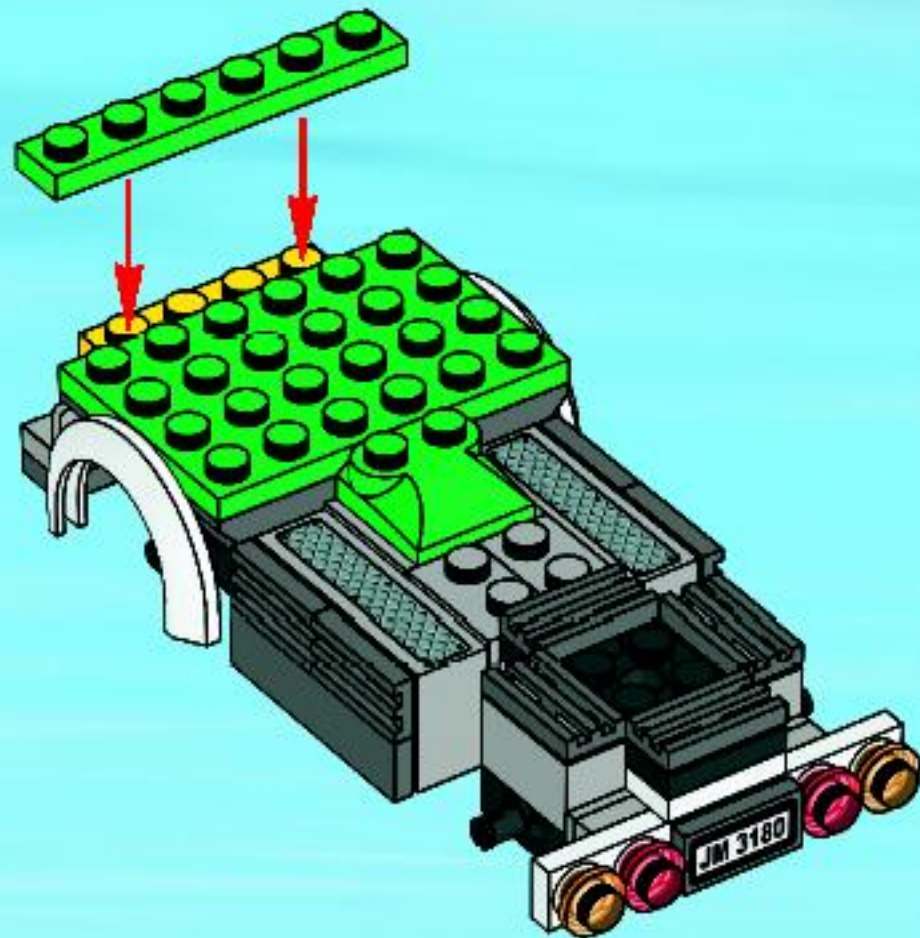

19

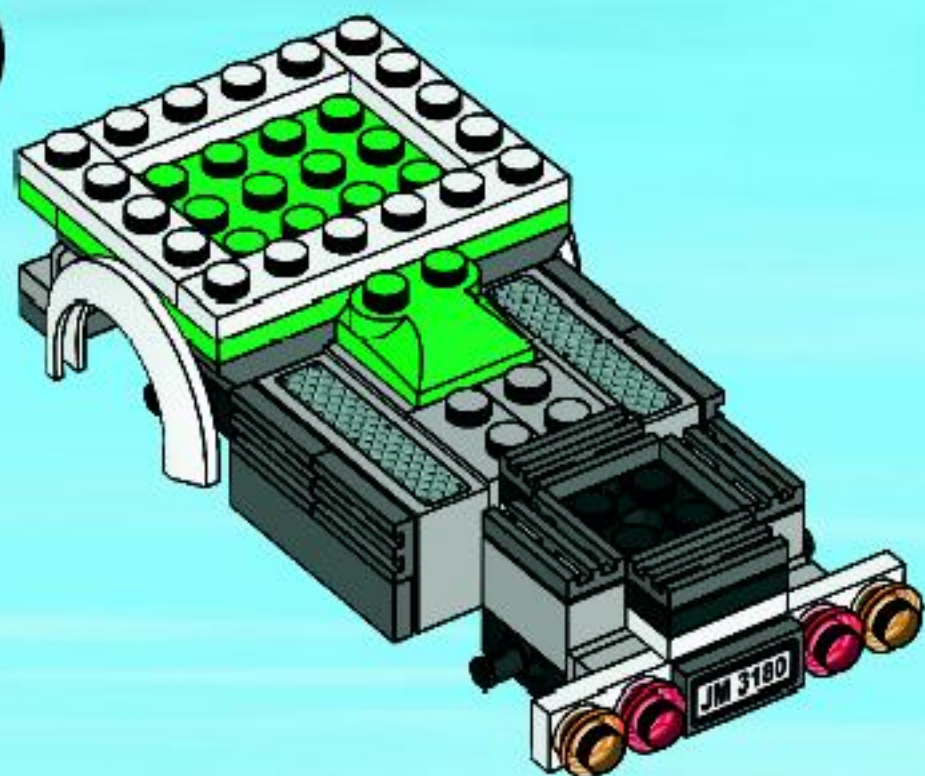

20

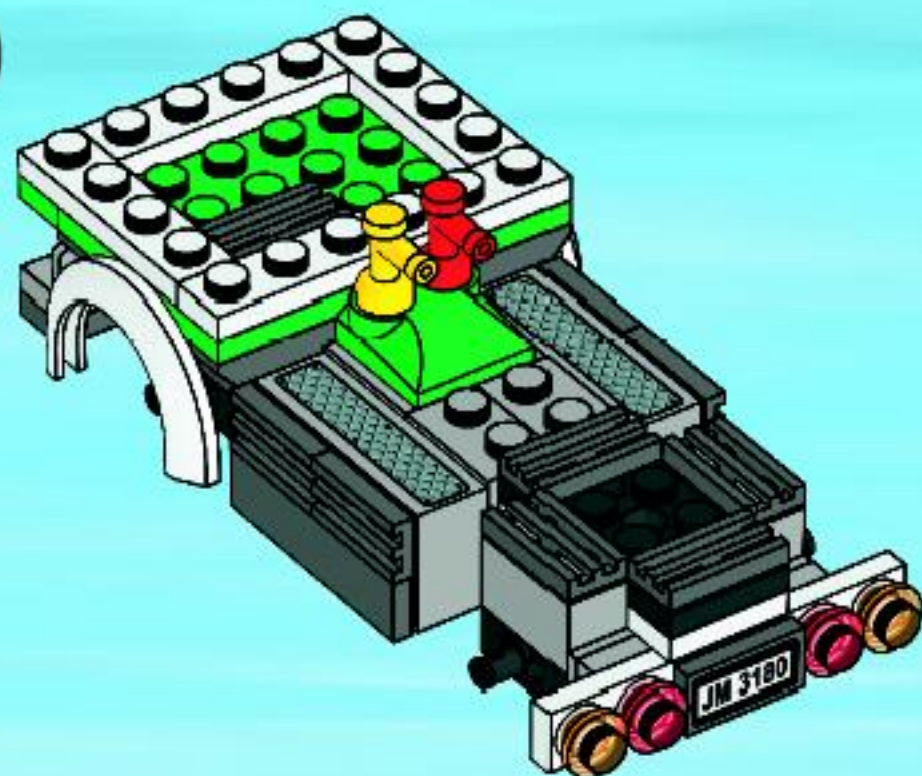

21

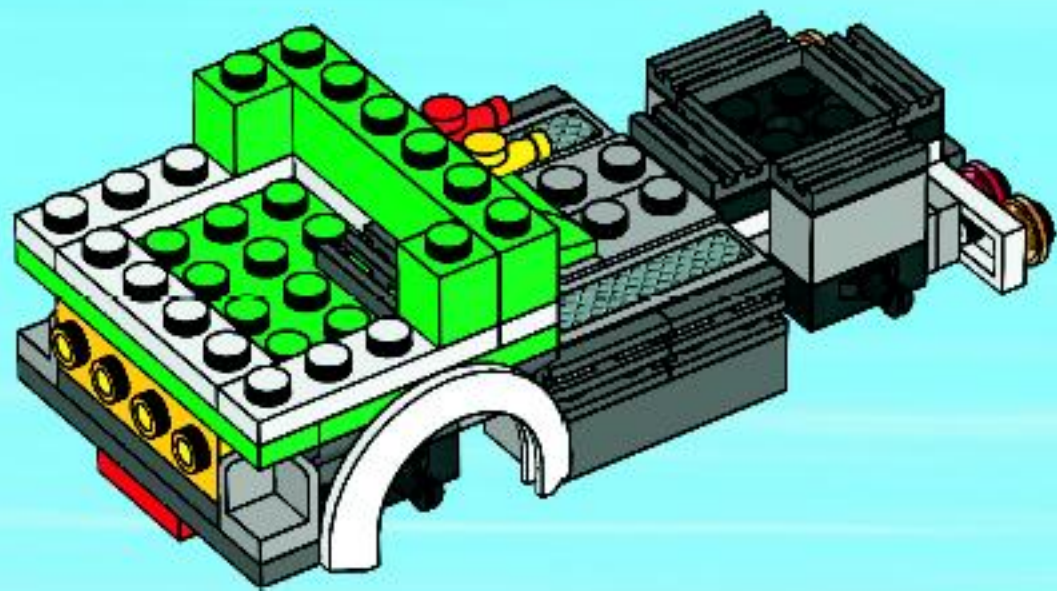

22

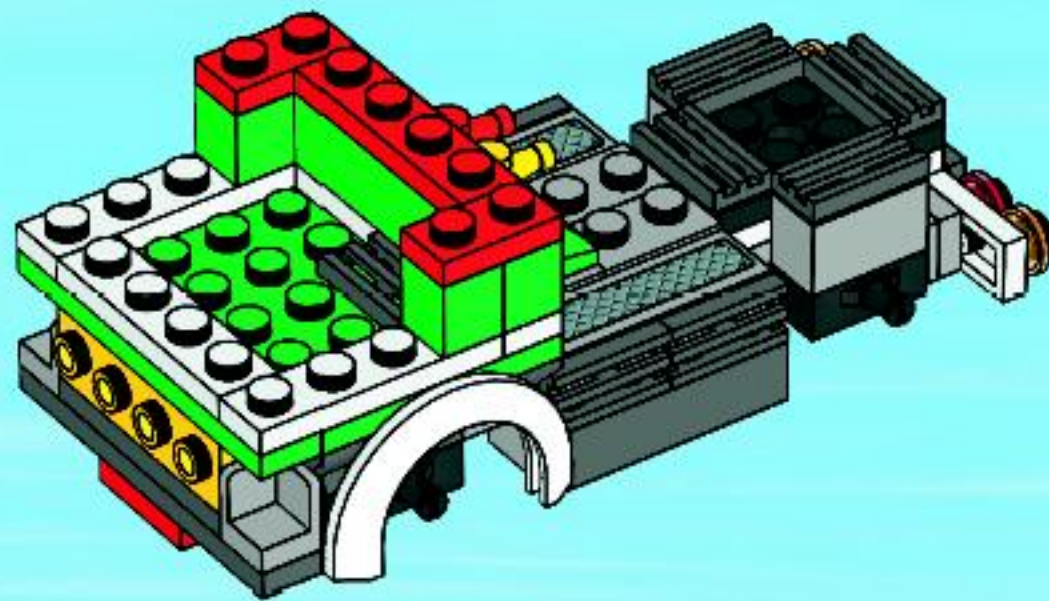

23

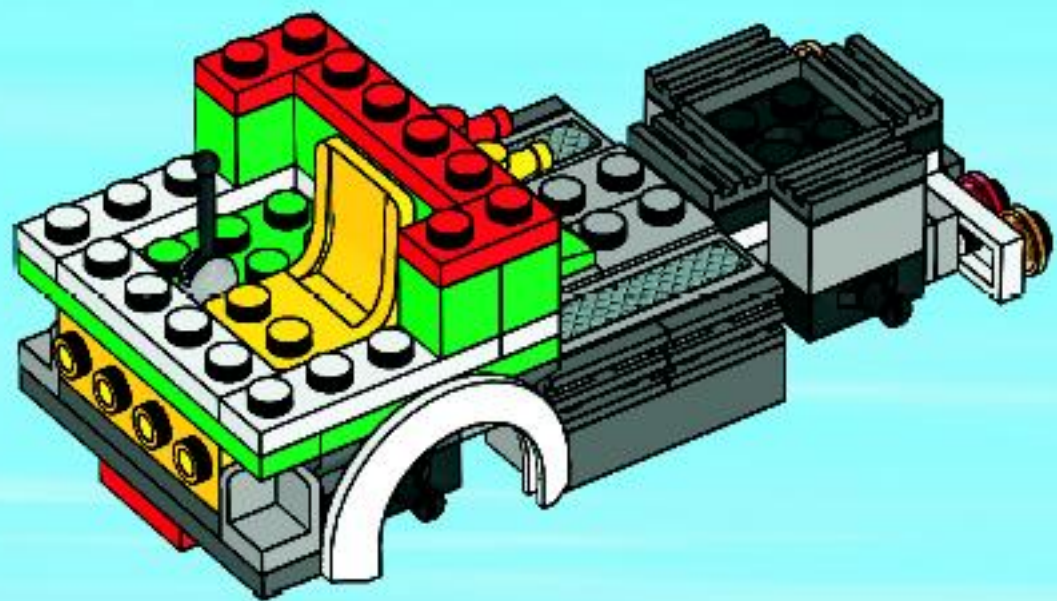

24

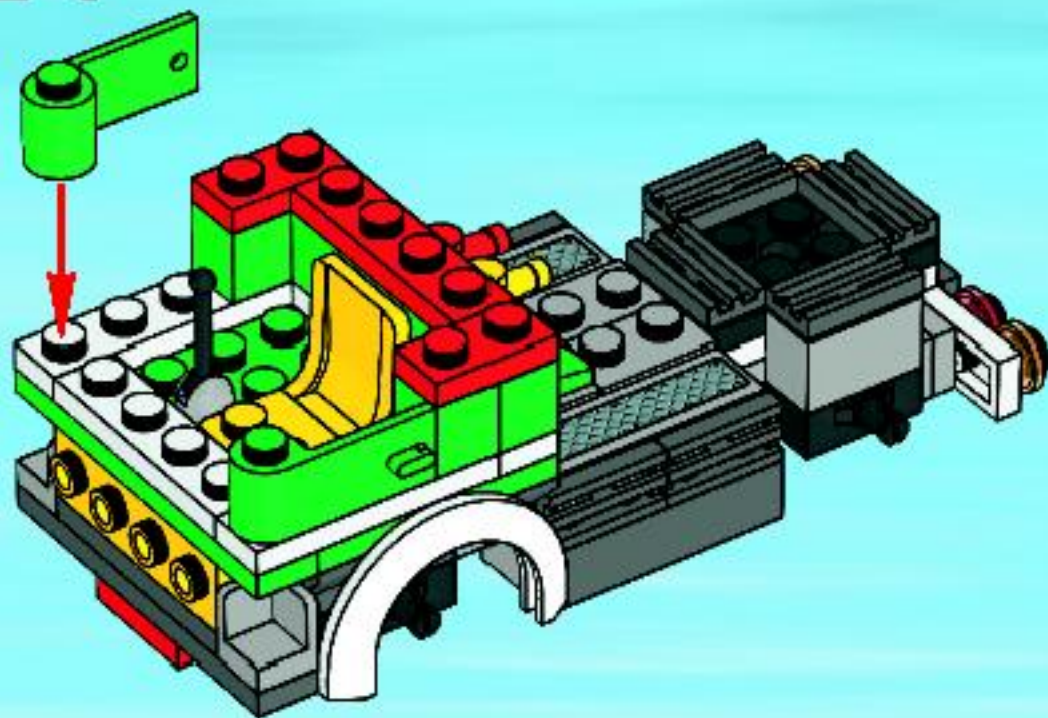

25

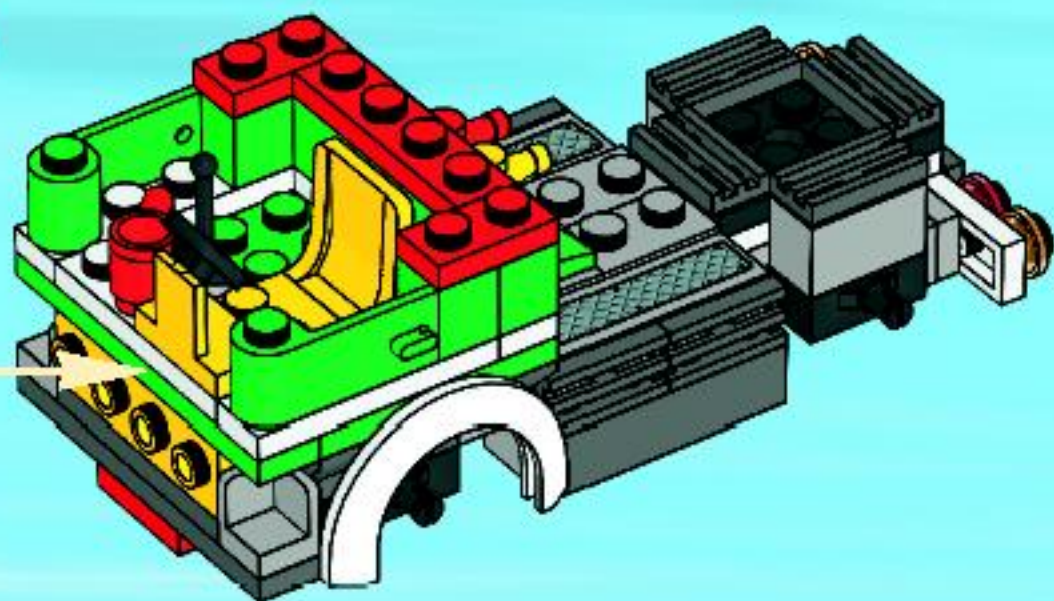



1

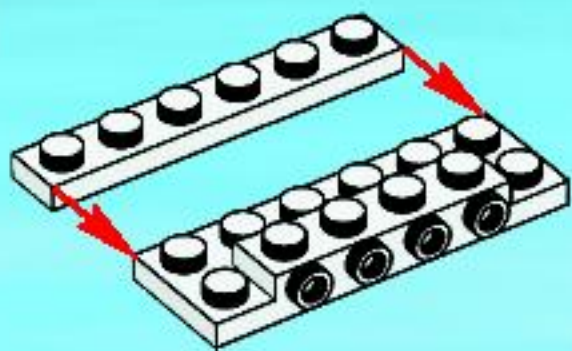

2

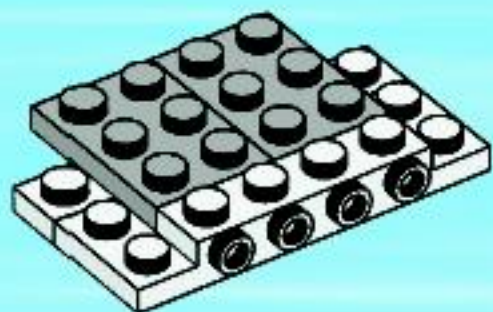

3



4

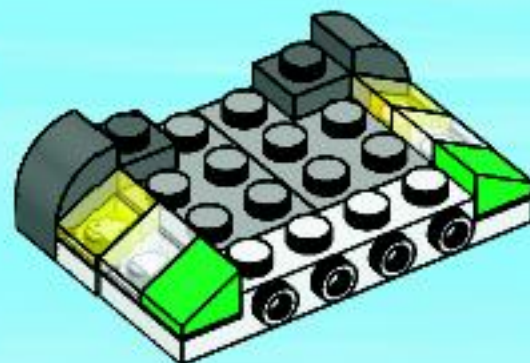

5

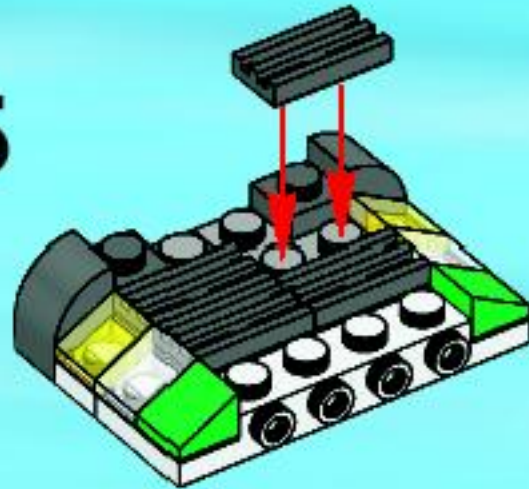

6

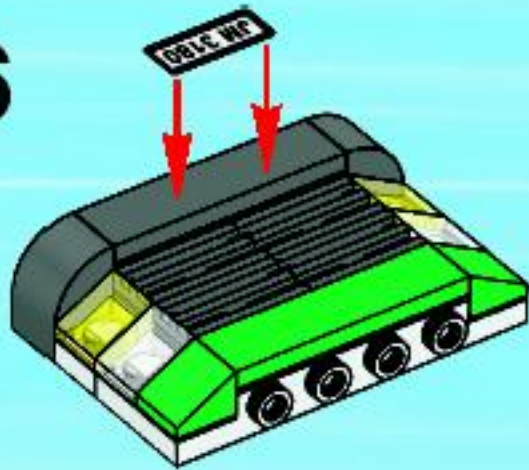

26

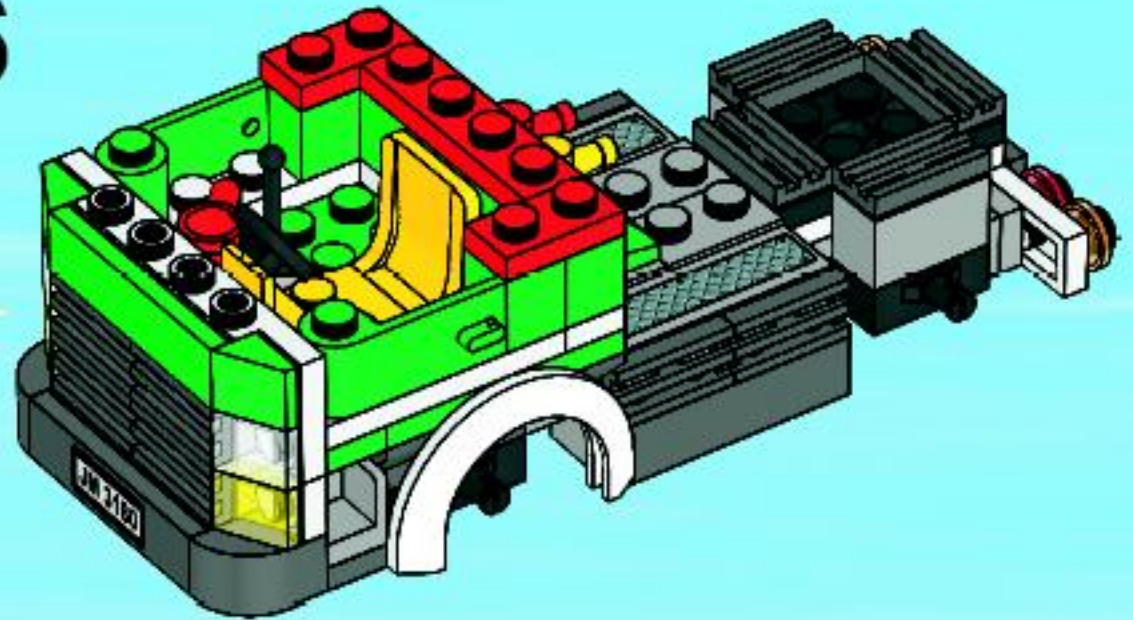



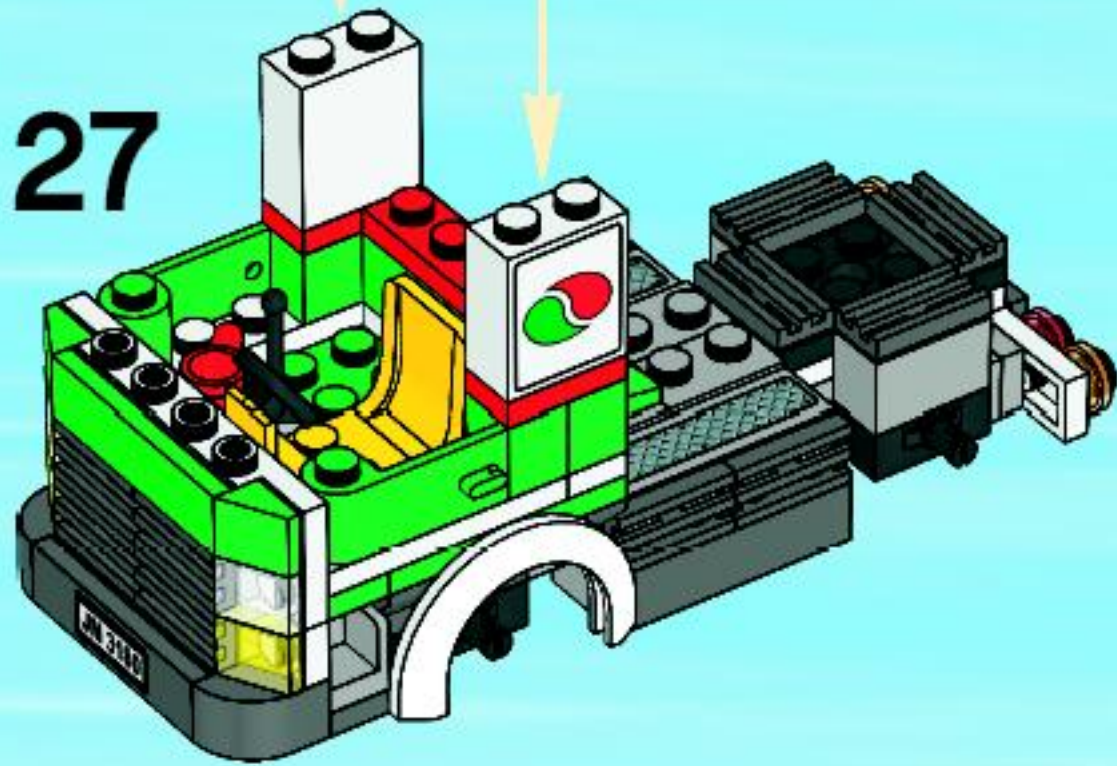
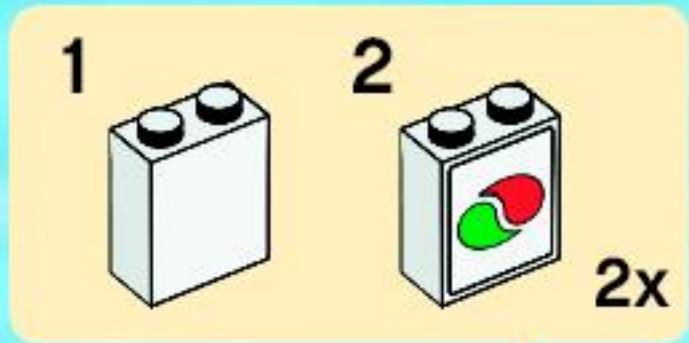

28

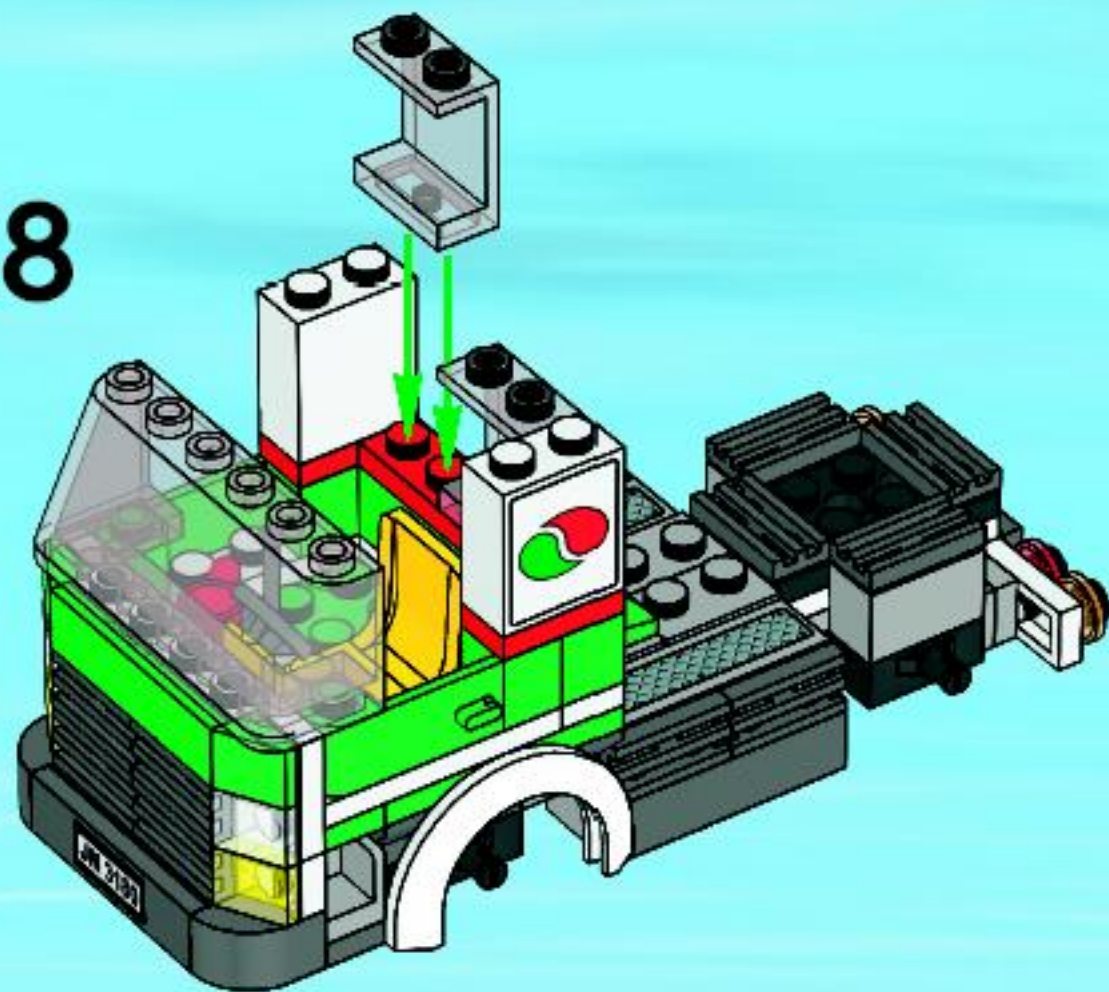

29

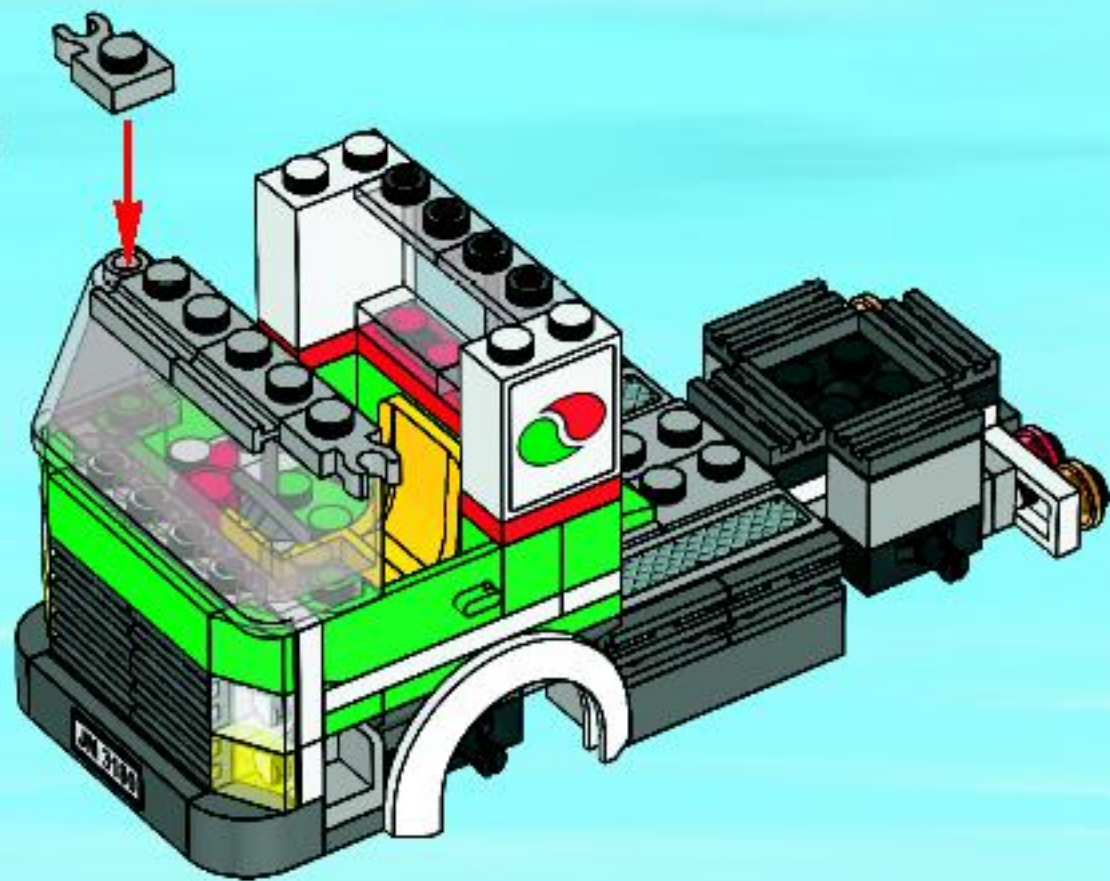

30

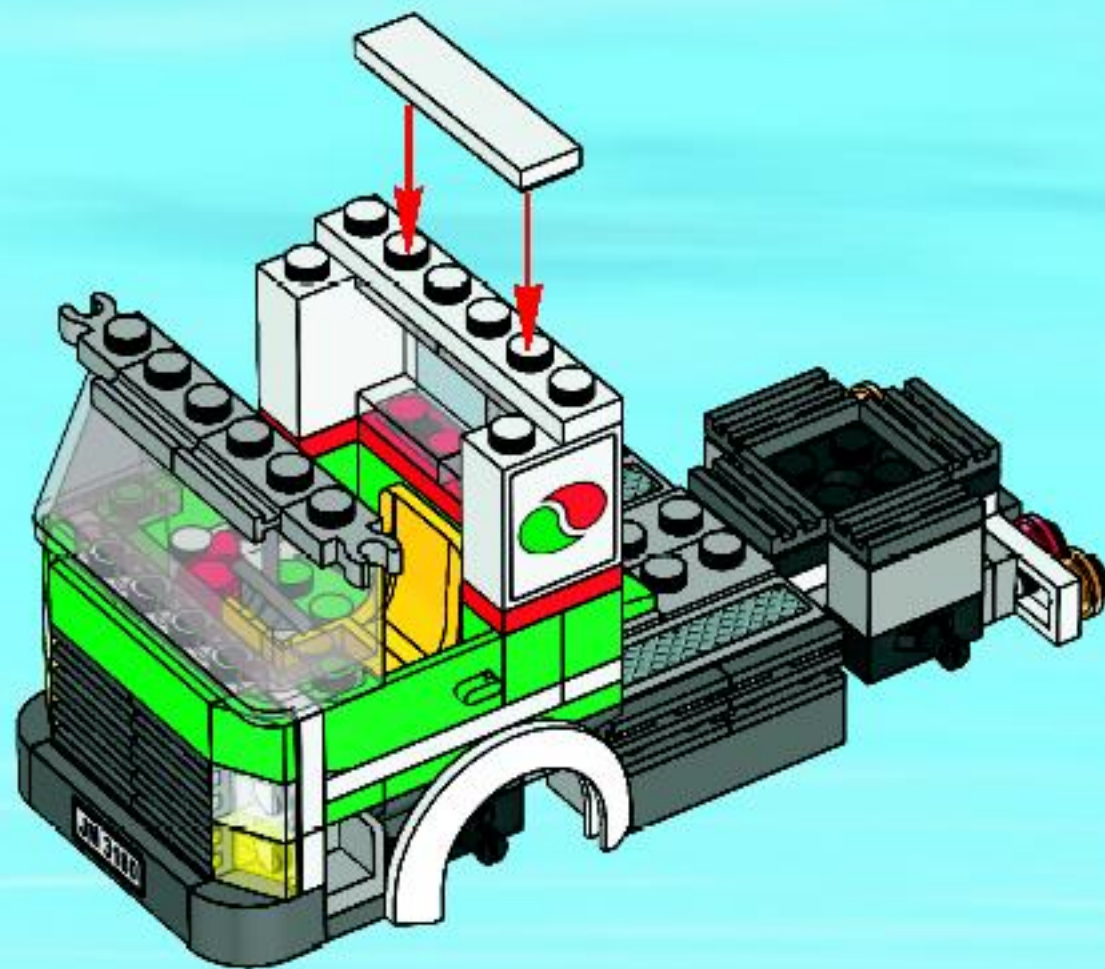

31

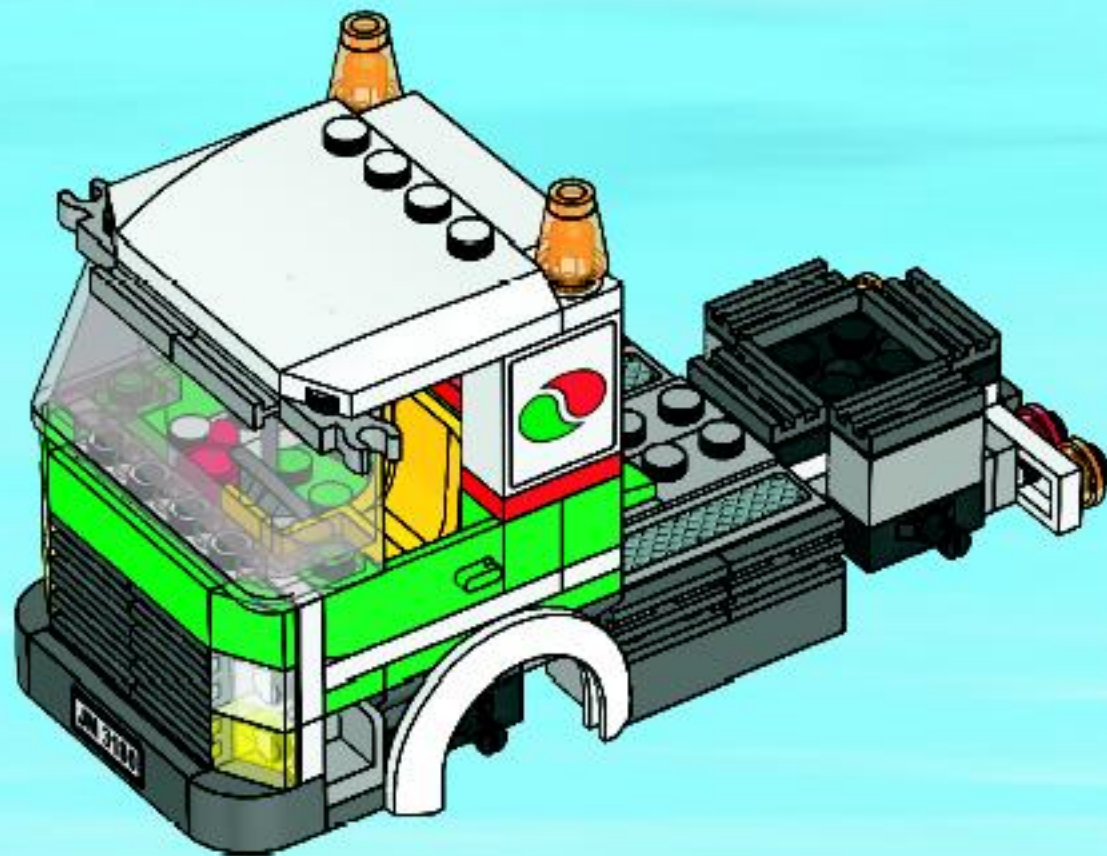

32

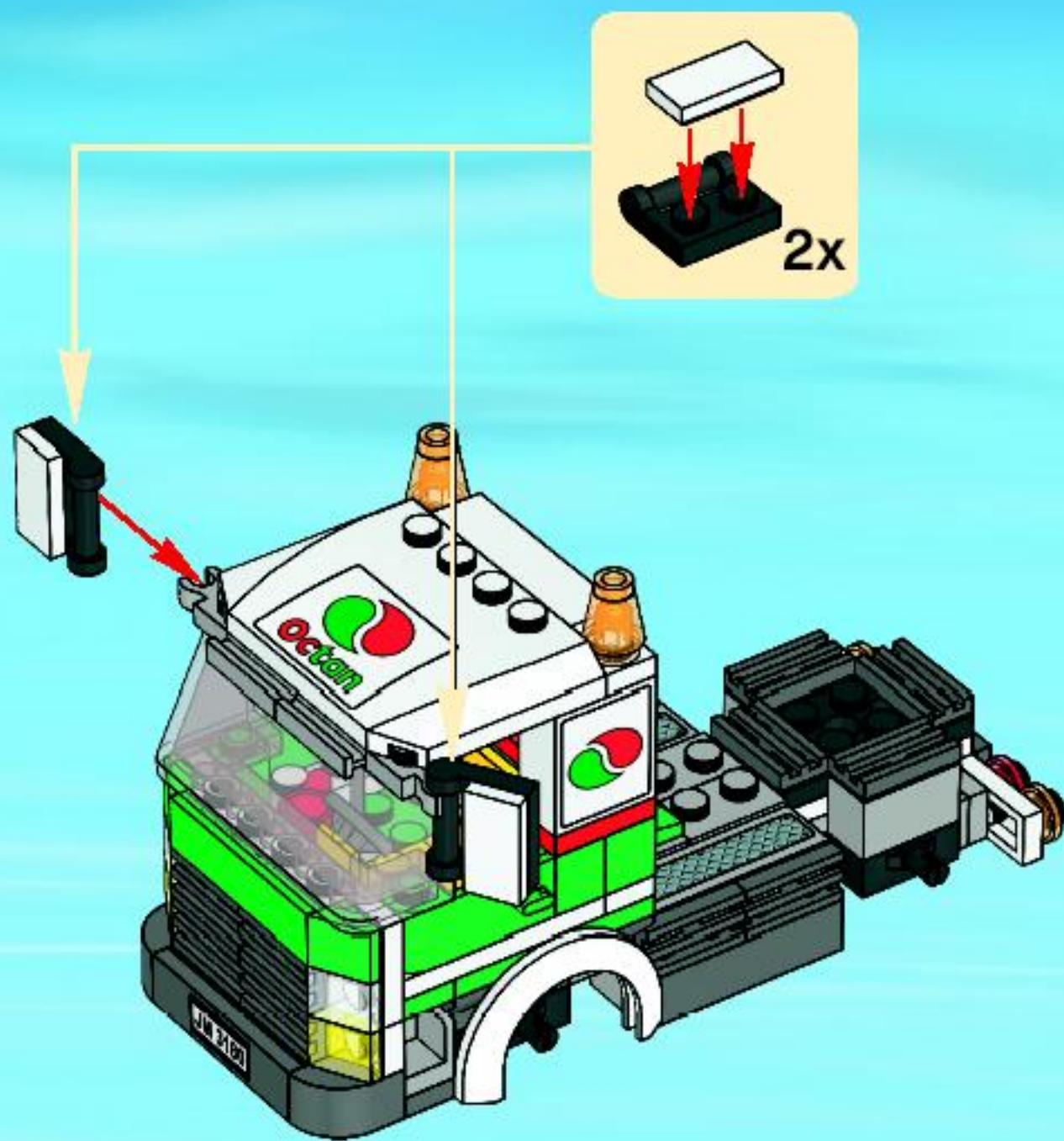

33



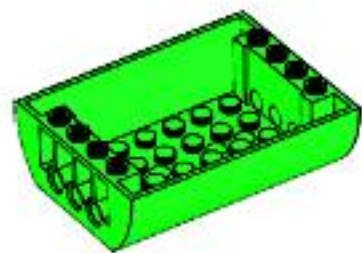

3x

+



1x

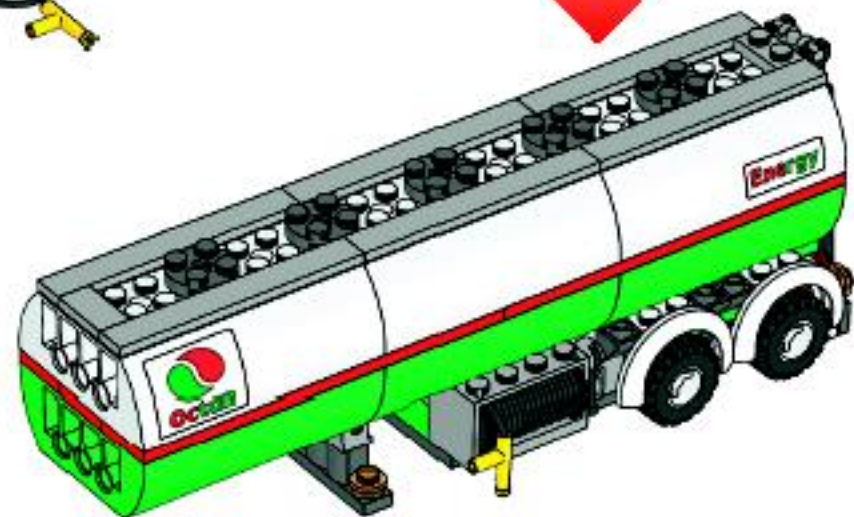

1

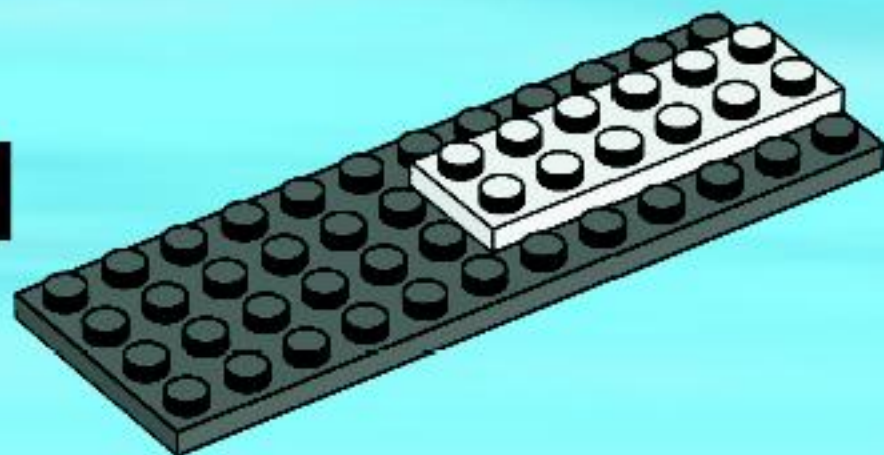

2

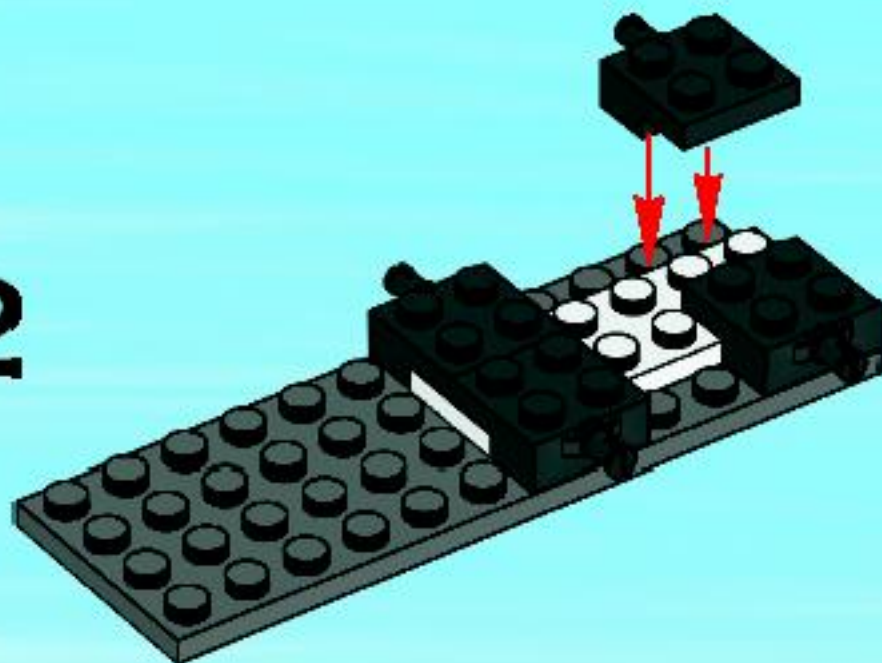



**3**

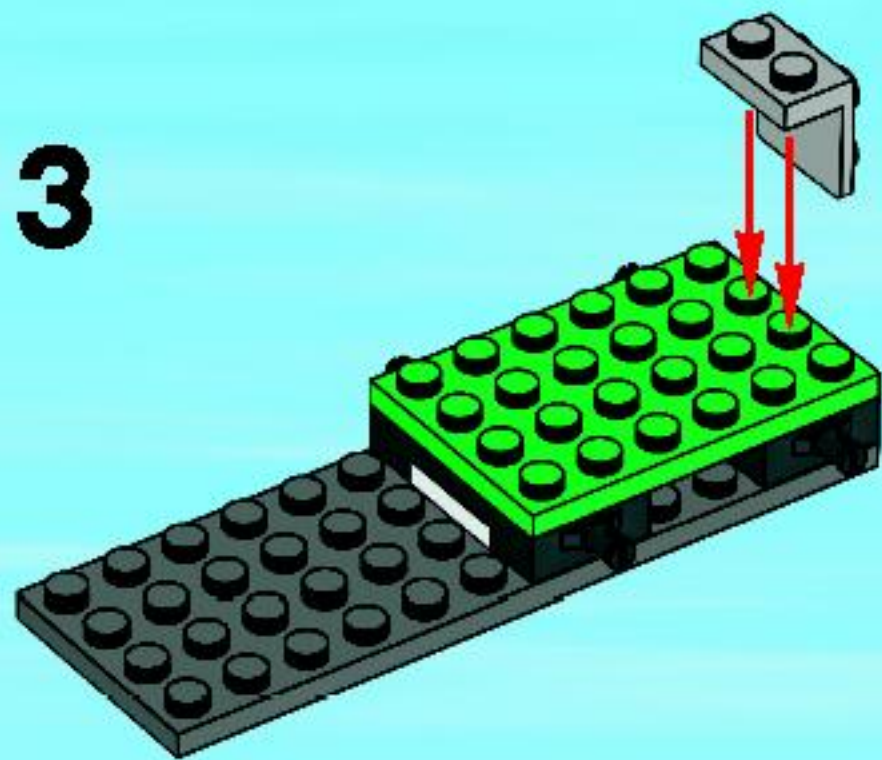

**4**

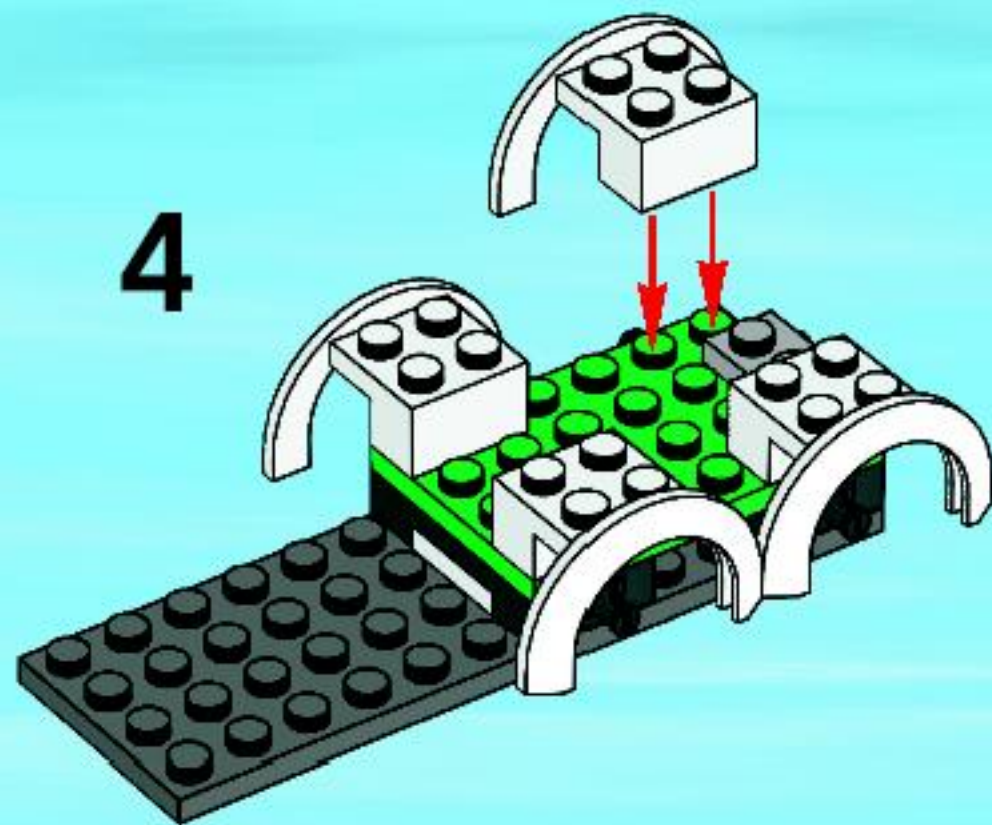

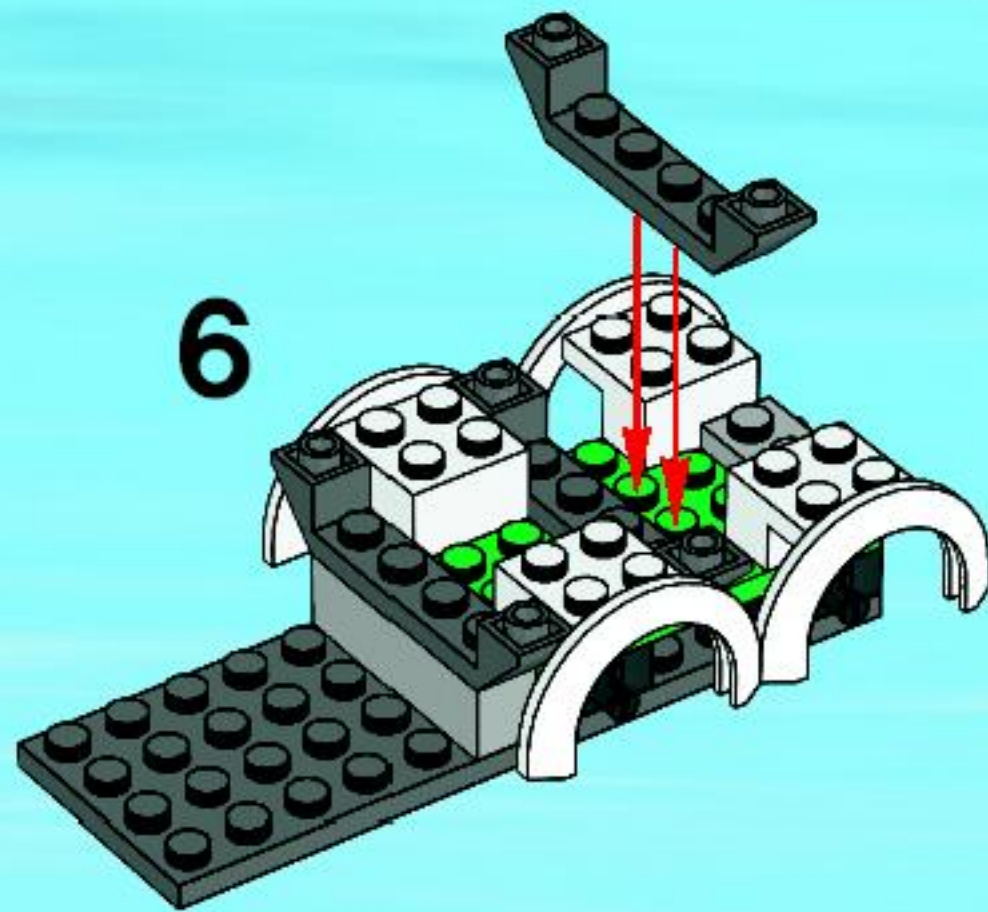
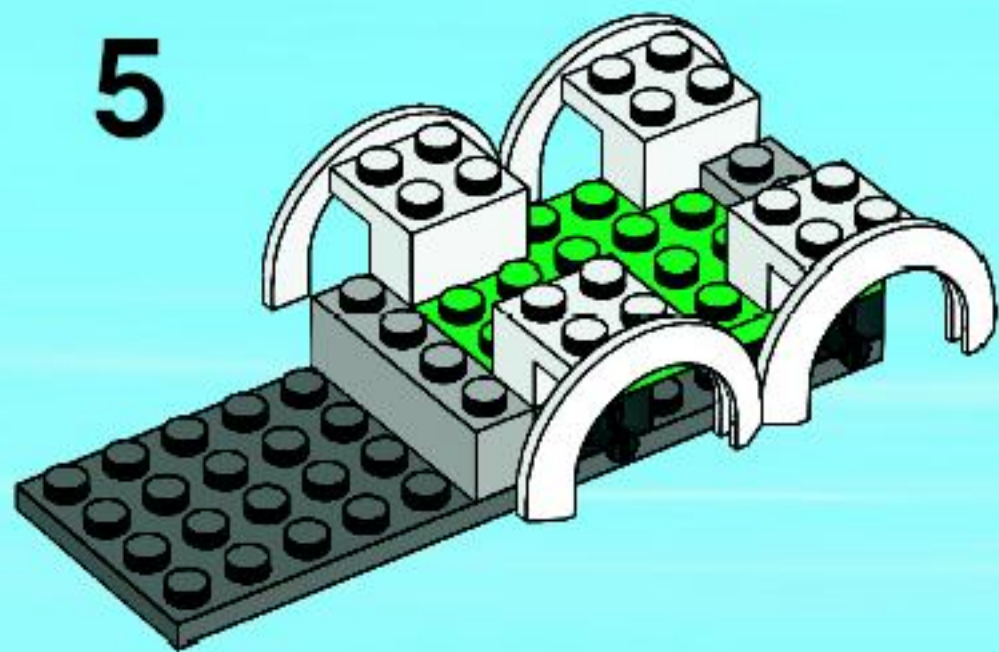

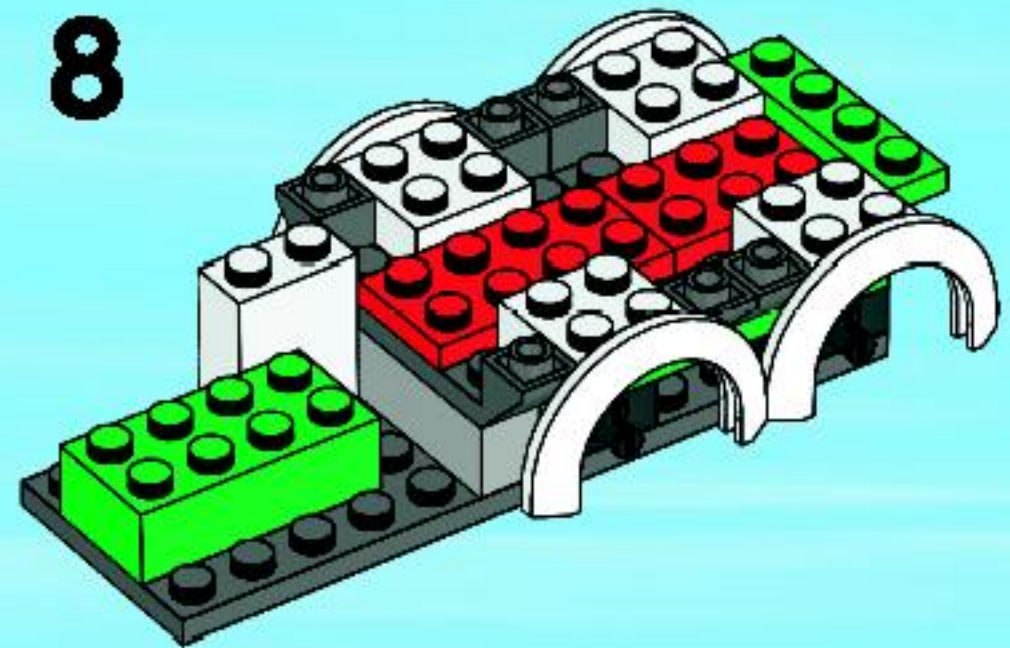
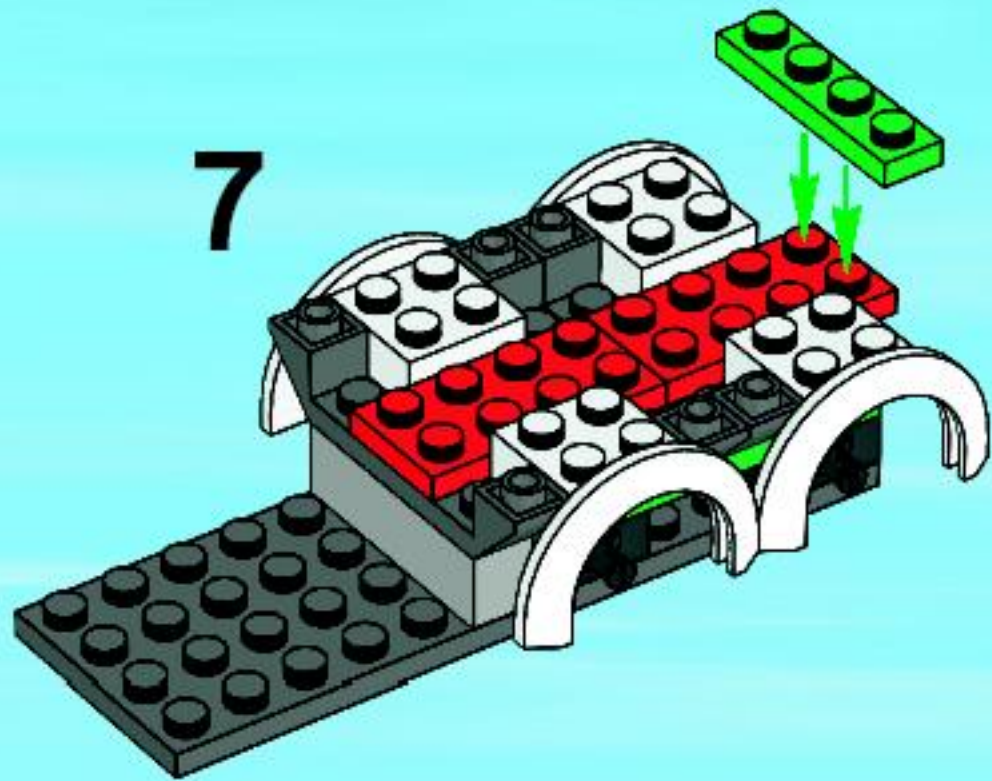

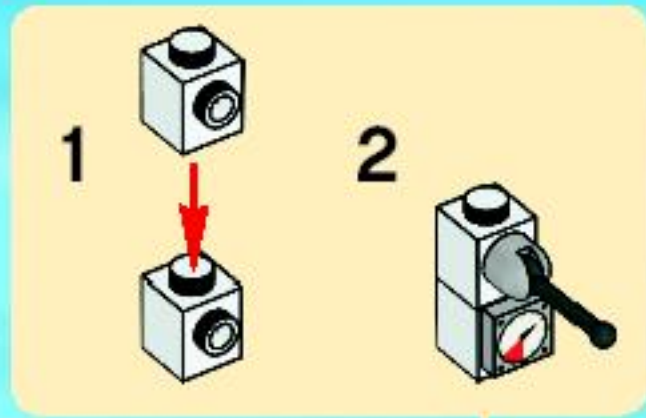

9

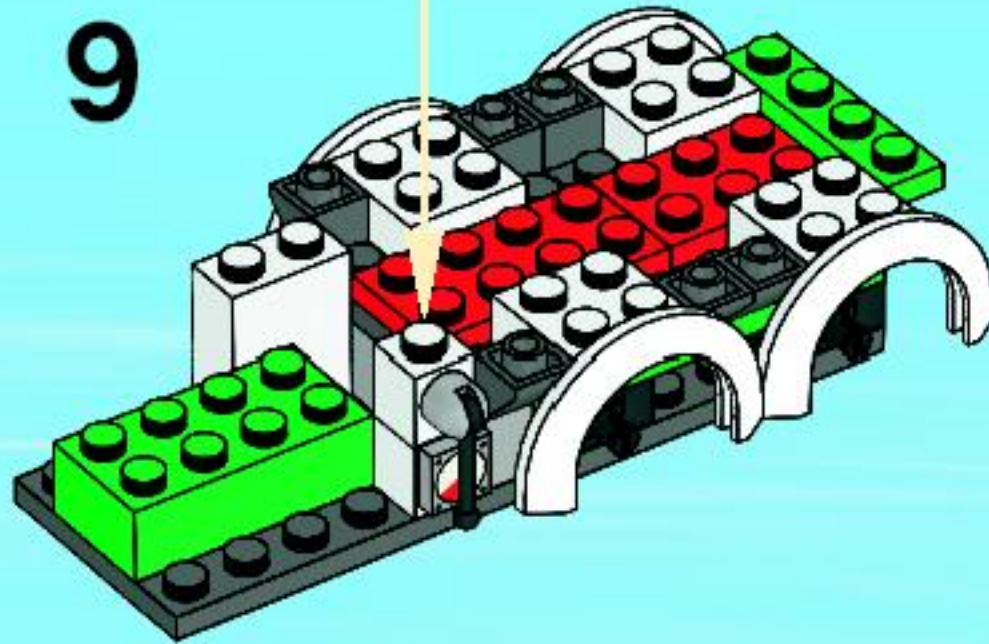

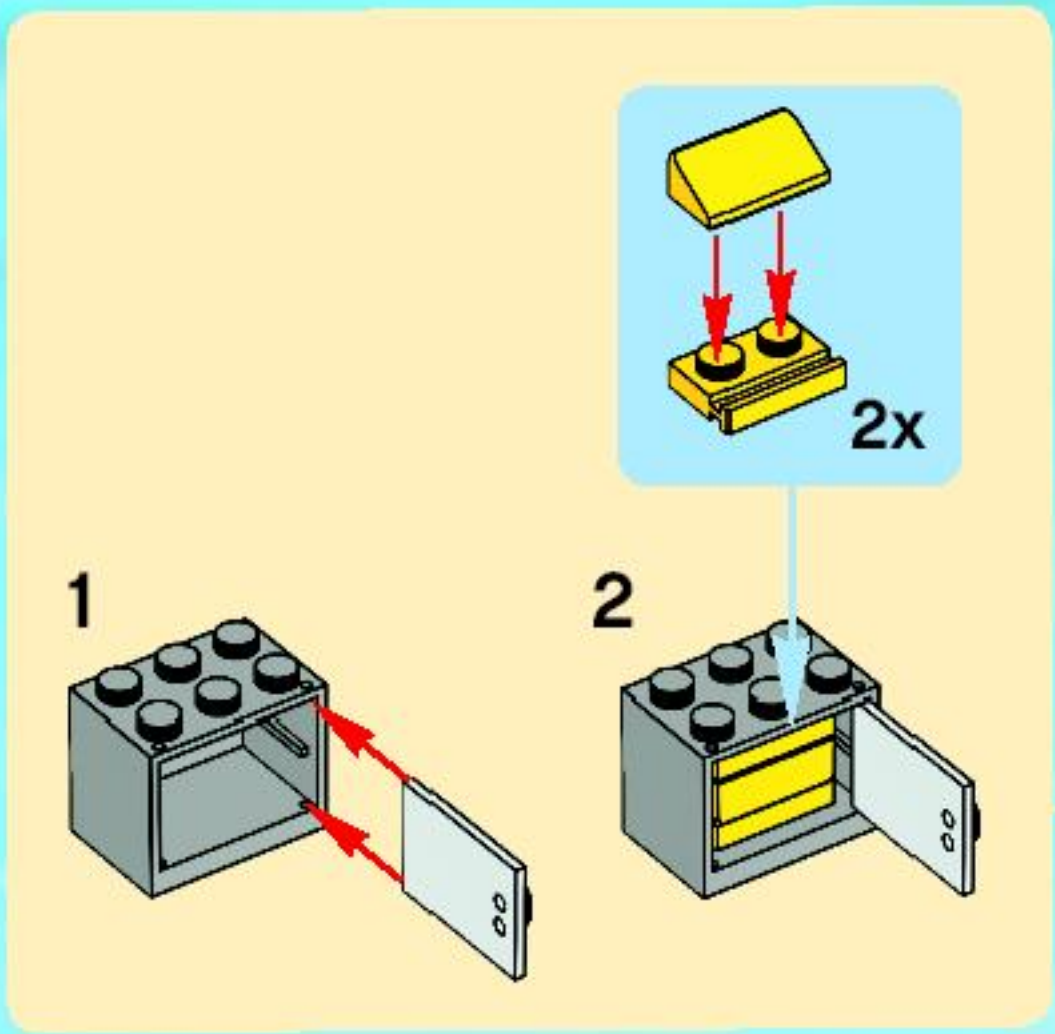

10

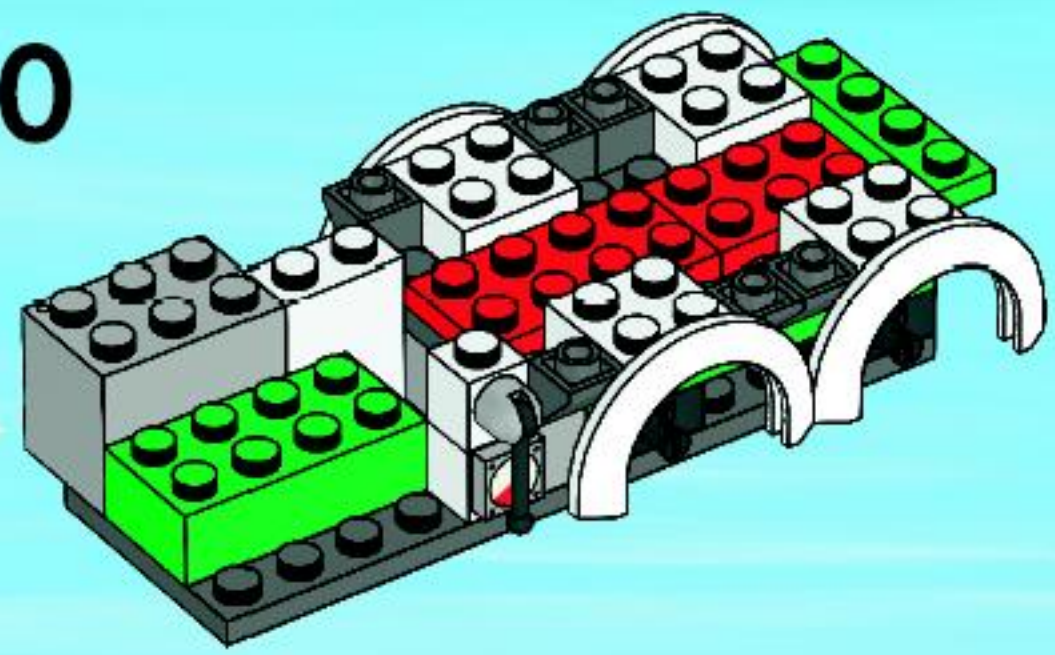

1



2



3

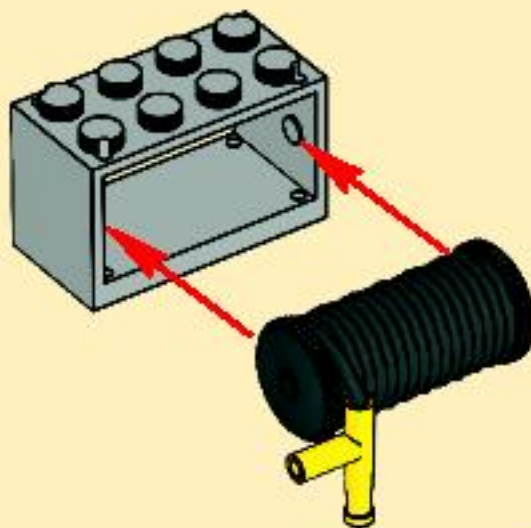

11

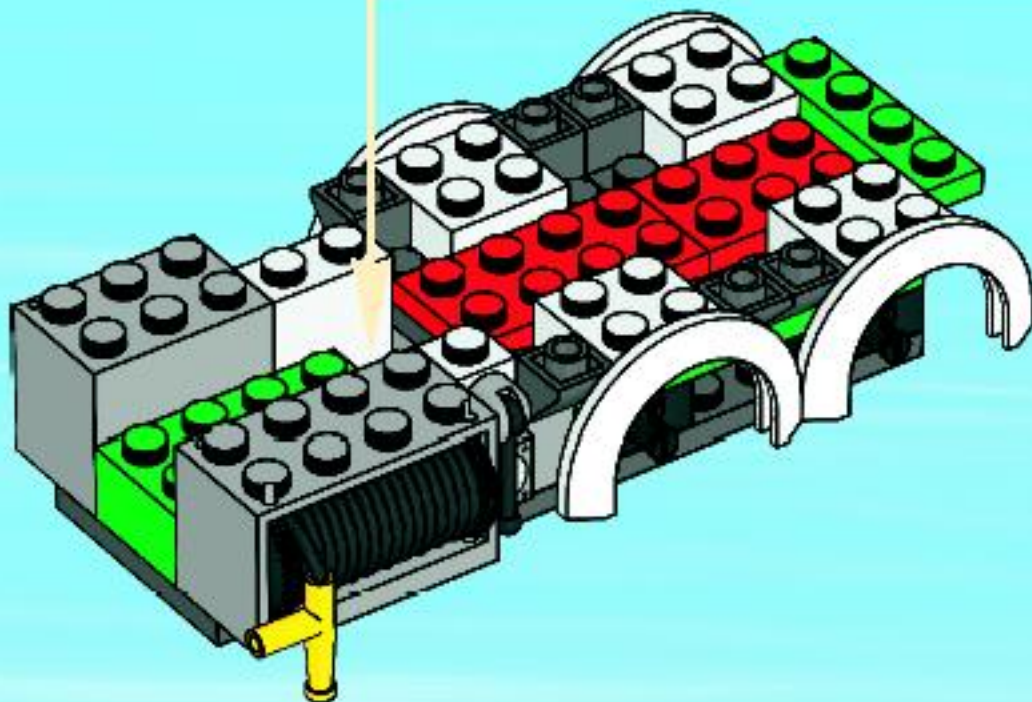

1



2



3

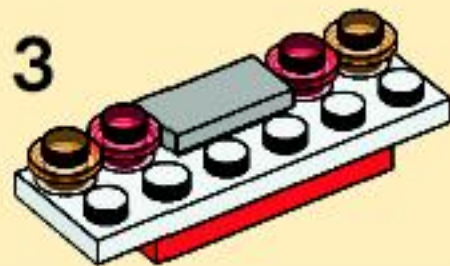

4

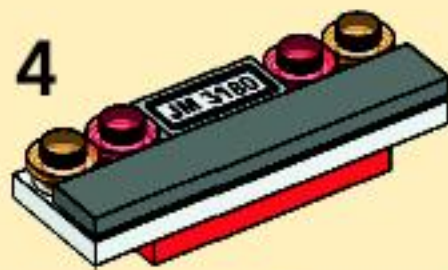

12

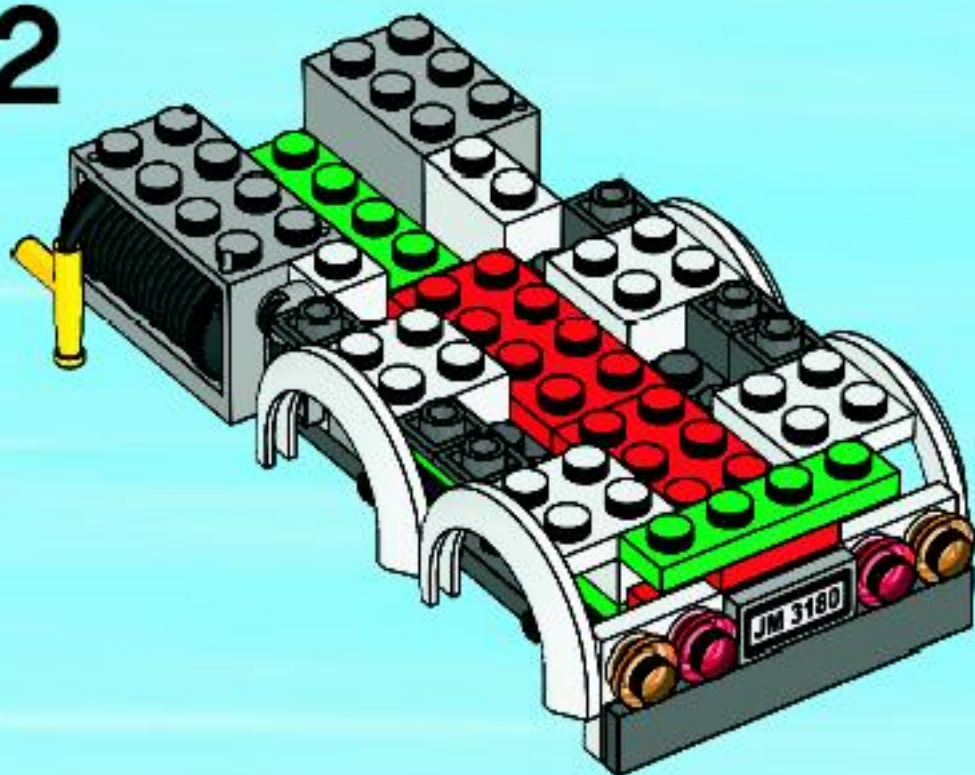

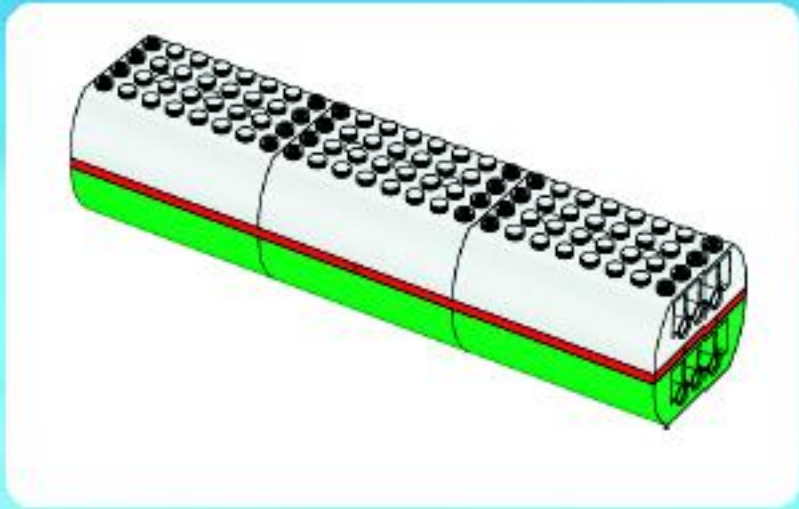

1

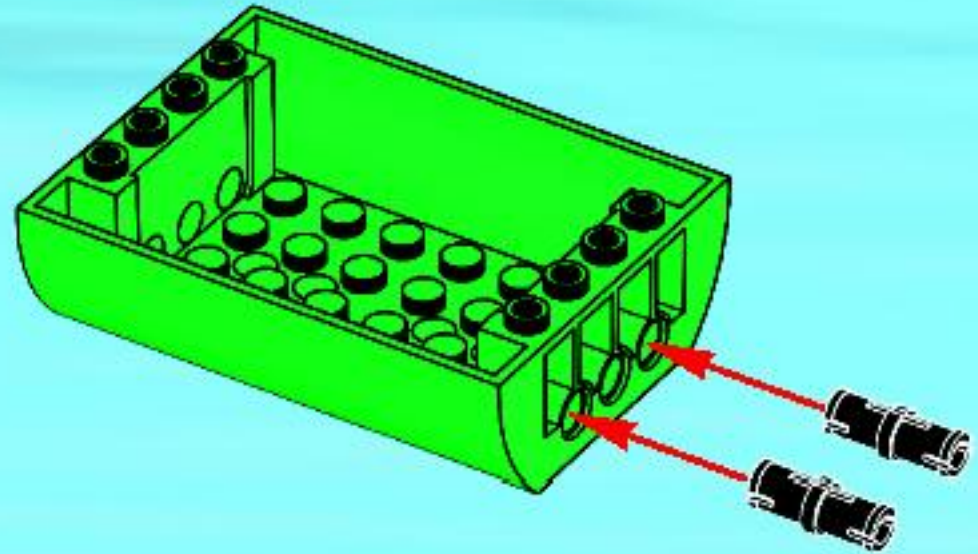



2

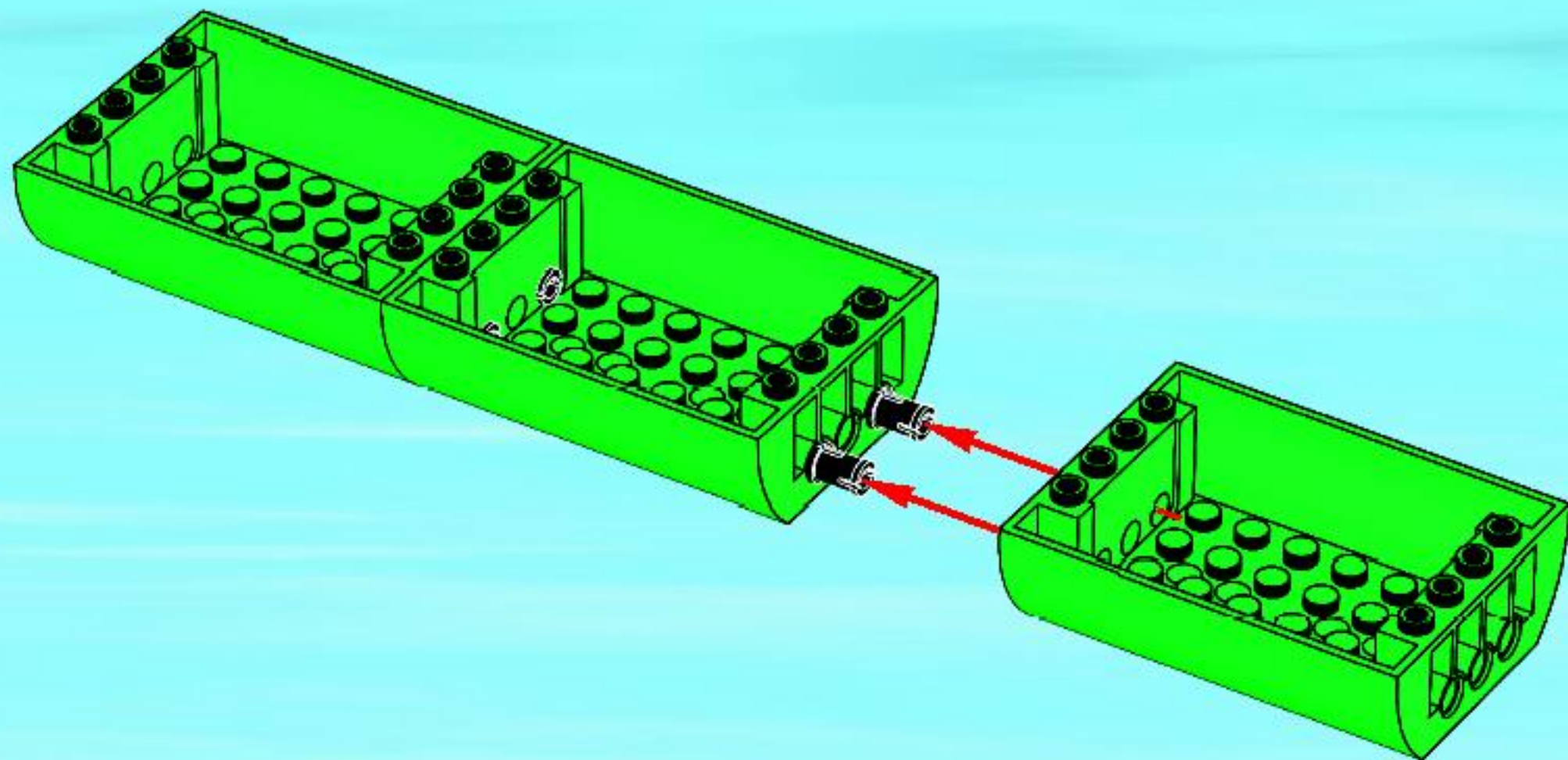

3

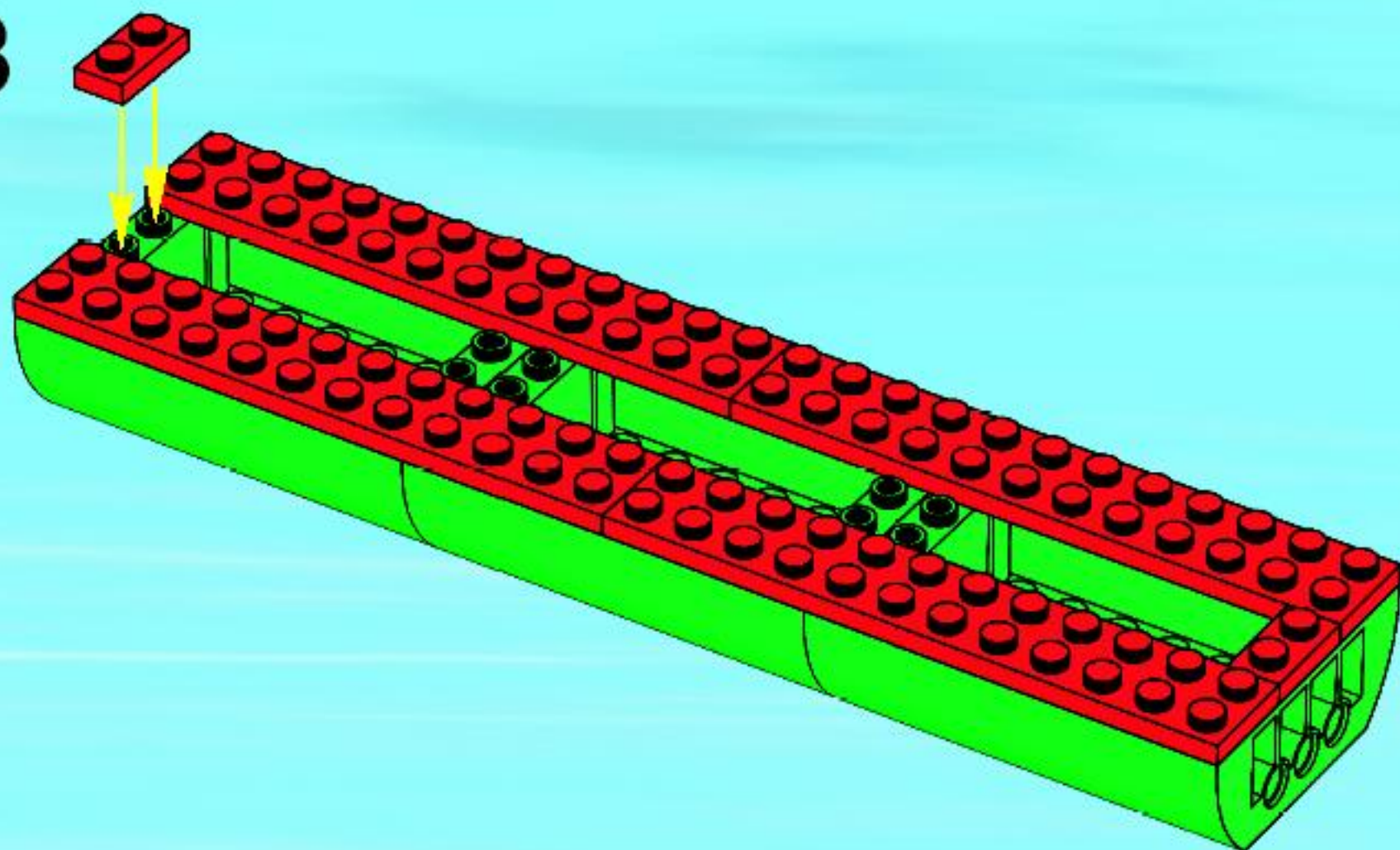

4

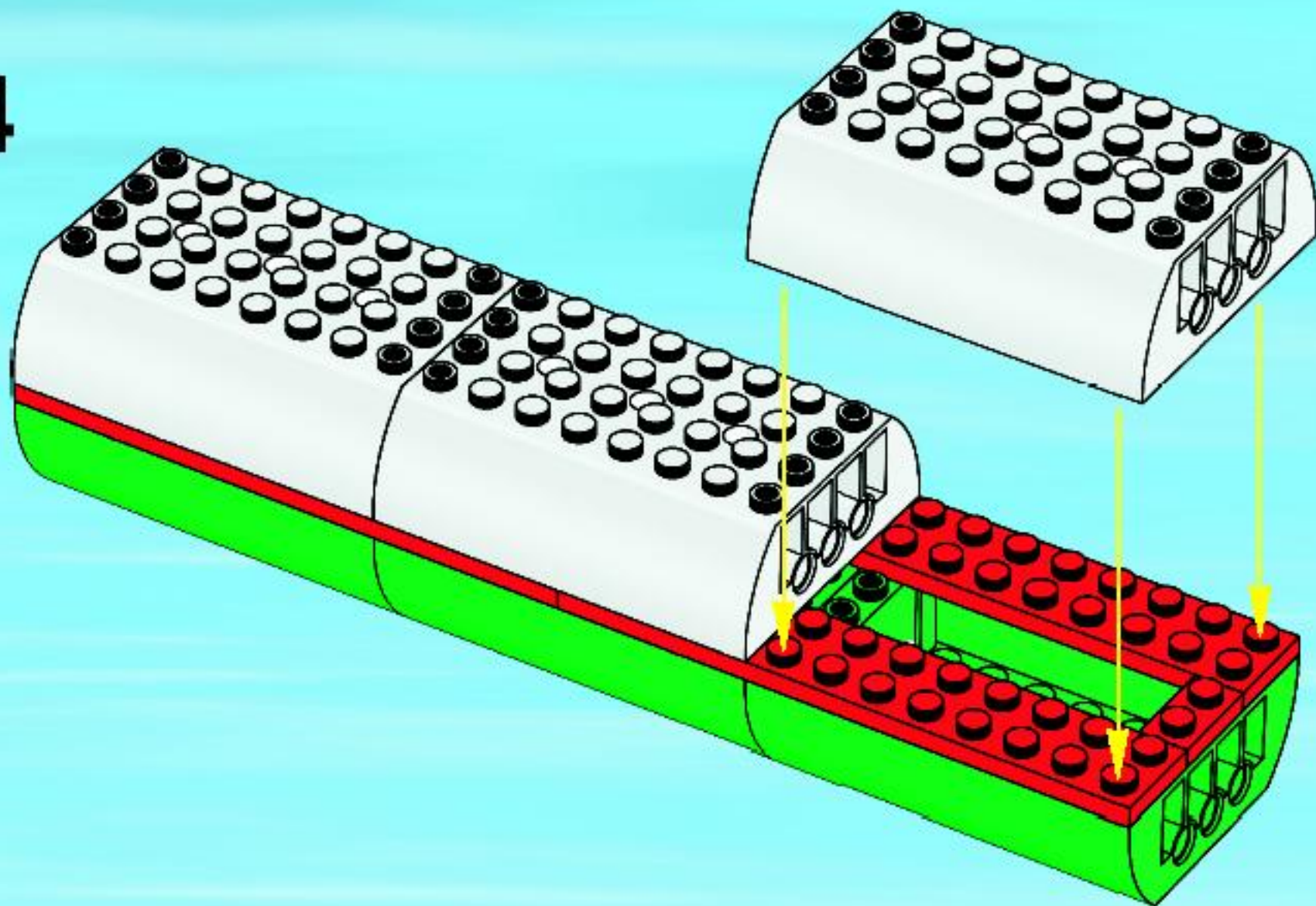

5

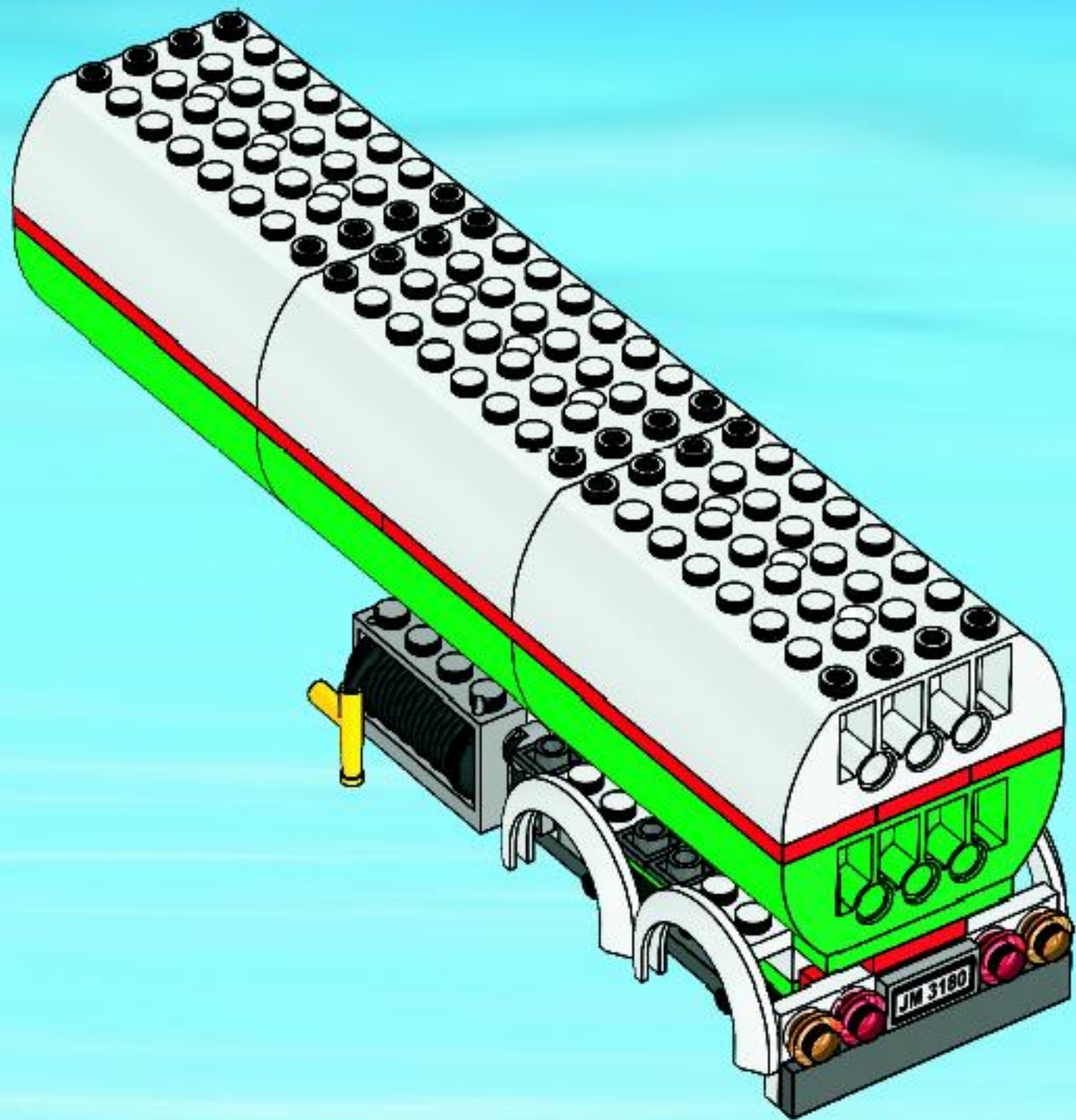

6



1

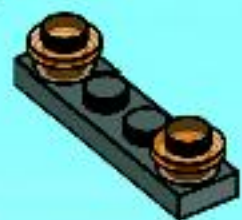

2

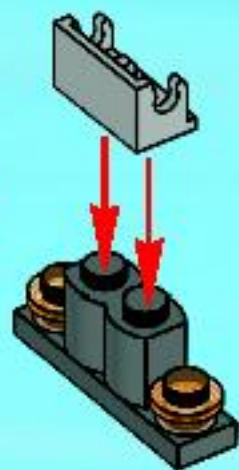

3

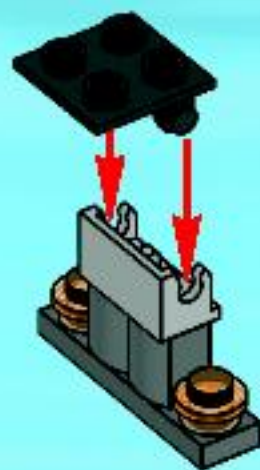

4

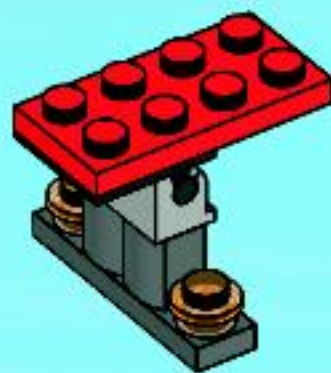

5

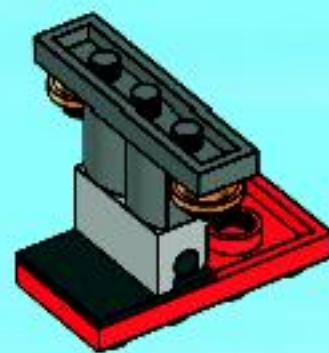

7

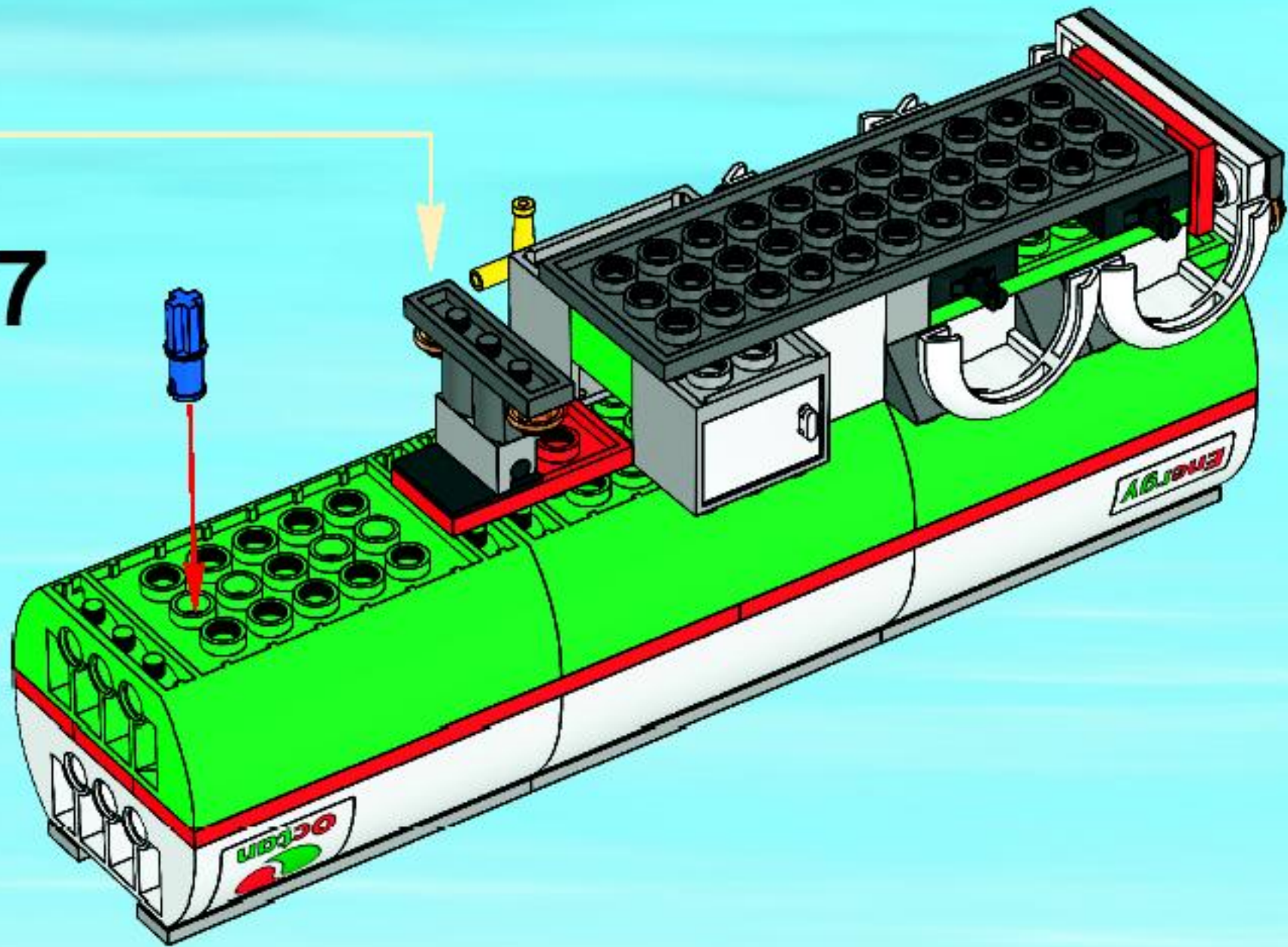

8

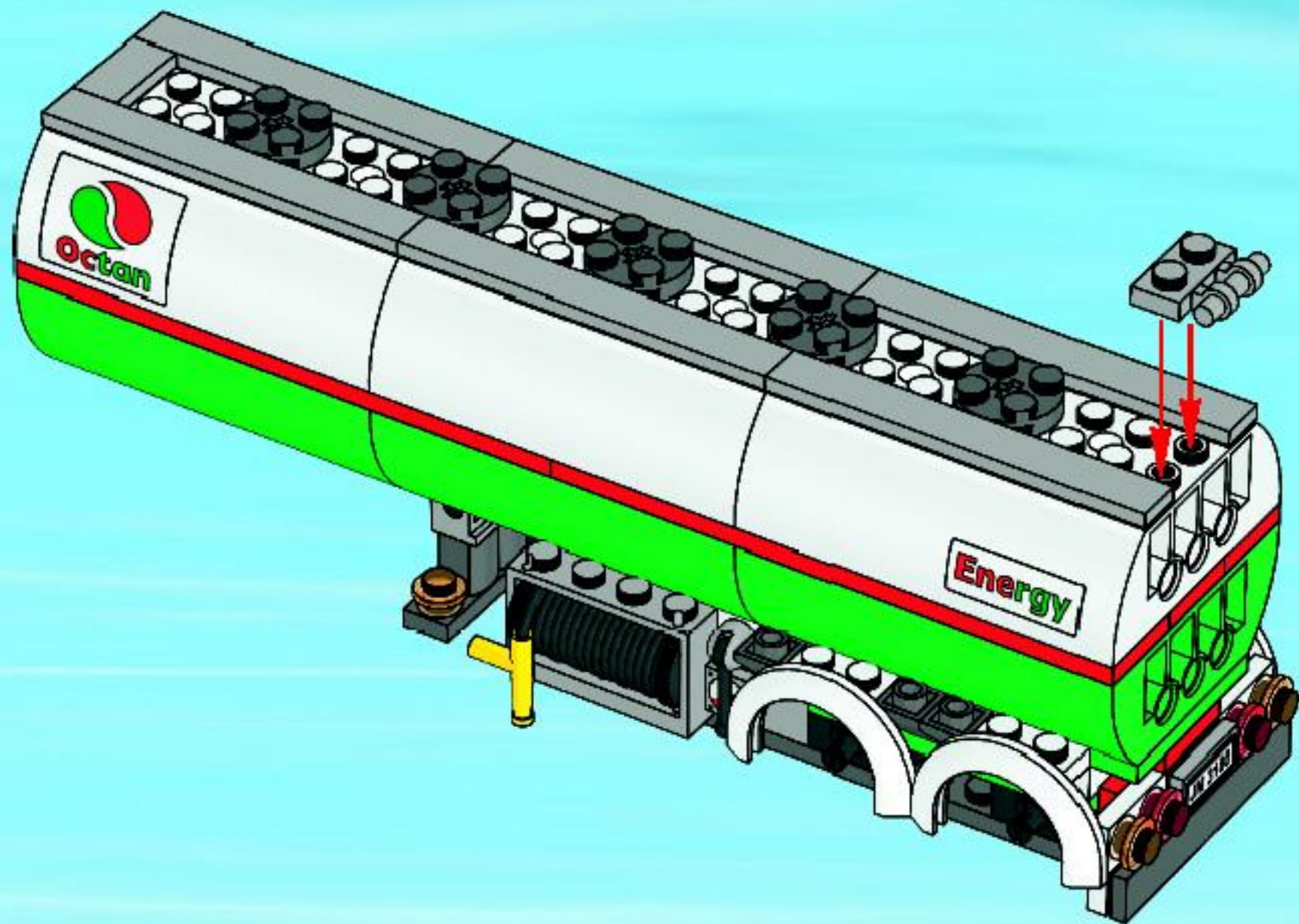



9



10

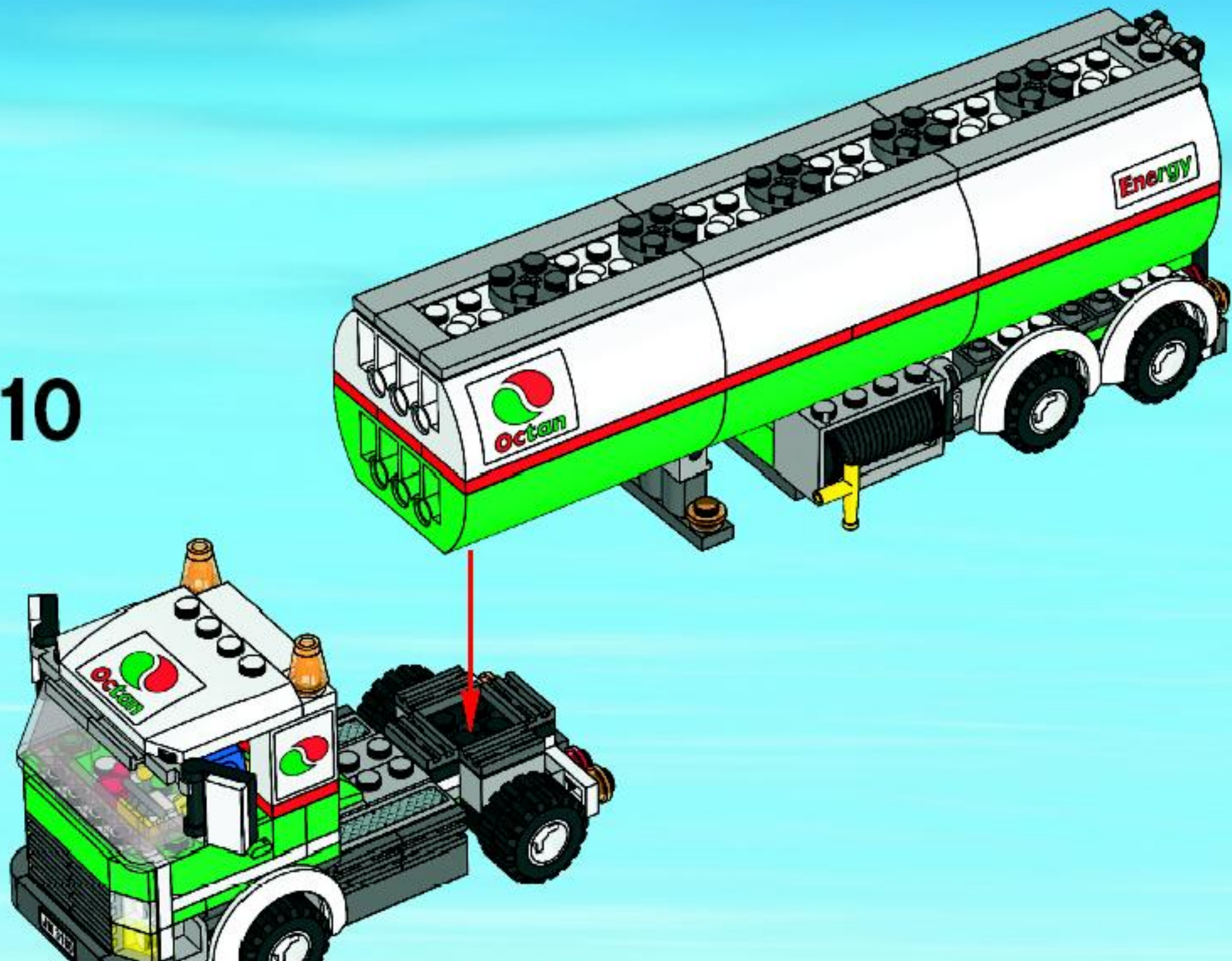

**LEGO**

**CITY**



3177



3178



3179



3180



3181



3182

**LEGO**

**CITY**



7241



7942



7239



7208



7207

**FREE! GRATIS! GRATUIT!**



**club**  
MAGAZINE™

**www.LEGOclub.com**



**00800 5346 5555\***        

  **1-866-534-6258 • 1-877-518-5346**

US & Canada only

Canada seulement

\* Free phone. Mobile charges may apply. \* Numéro sans frais. Des frais peuvent s'appliquer avec les téléphones cellulaires. \* Gebührenfrei, Kosten für Anrufe aus Mobilfunknetzen können anfallen.

\* Gratis telefonnummer van vaste lijn. \* Det er ett gratis nummer, utgått du ringer från fasttelefon. \* Det är gratis, utgått du ringer från fasttelefon.



VISIT THE WORLD'S  
BIGGEST LEGO® SHOP!

**www.LEGOshop.com**

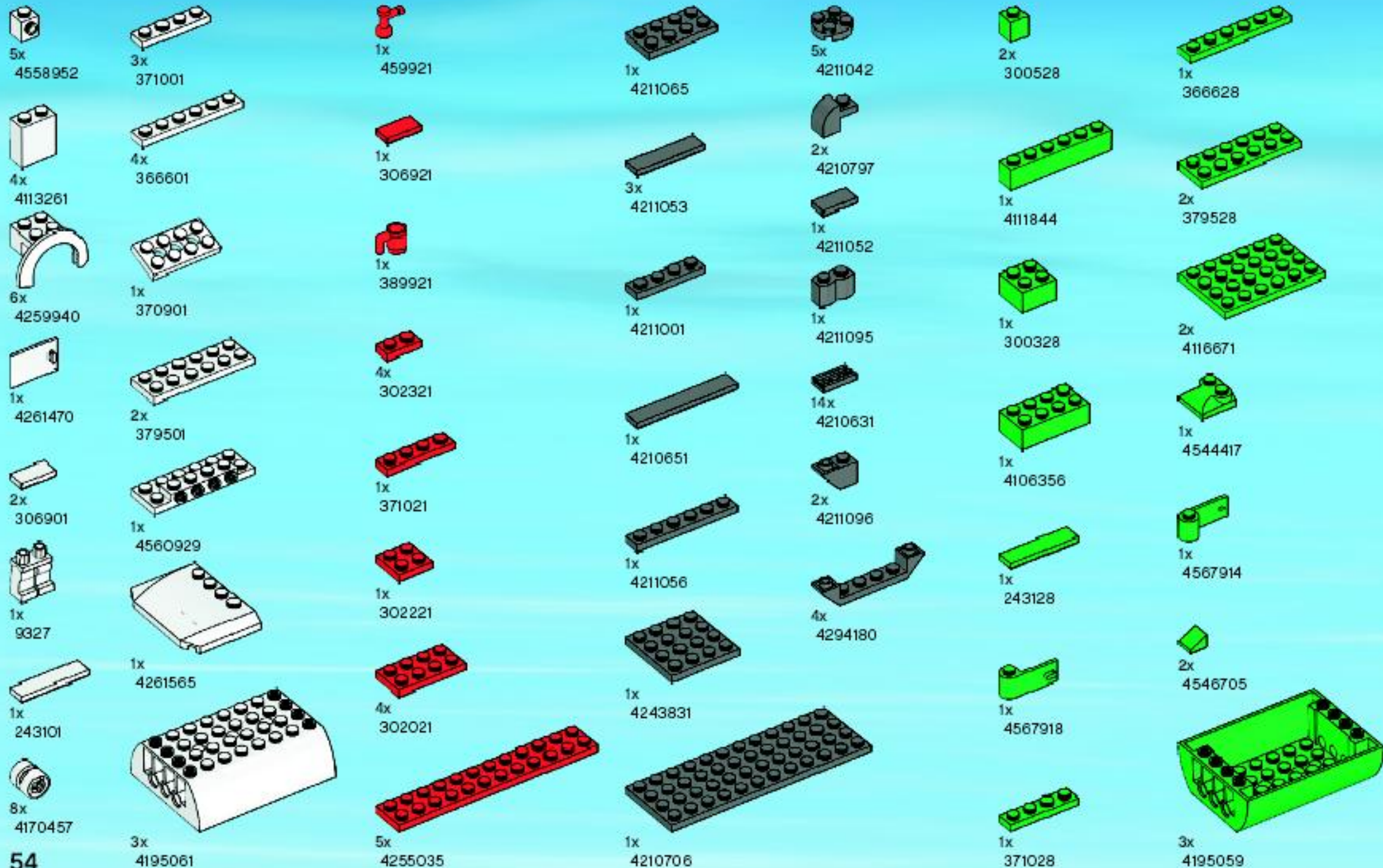



Customer Service  
Kundenservice  
Service Consommateurs  
Servicio Al Consumidor

[www.lego.com/service](http://www.lego.com/service) or dial



: 00800 5346 5555

: 1-800-422-5346



# WIN!

Go to [www.nielsen.com/LEGO](http://www.nielsen.com/LEGO) to fill out a survey for a chance to win a cool LEGO® Product.

No purchase necessary.

Open to all residents where not prohibited.



[www.LEGO.com](http://www.LEGO.com)



## [www.nielsen.com/LEGO](http://www.nielsen.com/LEGO)

### GEWINNE!

Nimm an der Umfrage auf [www.nielsen.com/LEGO](http://www.nielsen.com/LEGO) teil und hab die Chance ein cooles LEGO® Produkt zu gewinnen!

Die Teilnahme am Gewinnspiel führt zu keinerlei Kaufverpflichtungen. Teilnahme in allen nicht ausgeschlossenen Ländern möglich.

### WIN!

Ga naar [www.nielsen.com/LEGO](http://www.nielsen.com/LEGO), vul een enquêteformulier in en maak kans op een cool LEGO® product.

Geen aankoopverplichting. Iedereen mag deelnemen, uitgezonderd ingezetenden van landen waar een enquêteverbod geldt.

### GAGNE!

Visite [www.nielsen.com/LEGO](http://www.nielsen.com/LEGO) pour répondre à un questionnaire et avoir une chance de gagner un produit LEGO® très cool!

Aucune obligation d'achat. Ouvert à tous les résidents des pays autorisés.

### 当てよう!

[www.nielsen.com/LEGO](http://www.nielsen.com/LEGO) にアクセスして、アンケートにご記入ください。当選者にはレゴ製品を差し上げます。

お買い上げの必須はありません。禁止されていない限り、すべての店舗にご利用いただけます。